

# **Development of Semi-Prefabricated Timber-Concrete Composite Floors in Australasia**

**David YEOH Eng Chuan**  
**Ph.D. Candidate**  
**University of Canterbury**  
**Christchurch, New Zealand**

**Massimo FRAGIACOMO**  
**Associate Professor of Structural Design**  
**University of Sassari**  
**Alghero, Italy**

**Andy BUCHANAN**  
**Professor of Timber Design**  
**University of Canterbury**  
**Christchurch, New Zealand**

**Keith CREWS**  
**Professor of Structural Engineering**  
**University of Technology**  
**Sydney, Australia**

**Jenny HASKELL**  
**Research Assistant**  
**University of Canterbury**  
**Christchurch, New Zealand**

**Bruce DEAM**  
**Leicester Steven EQC Lecturer**  
**University of Canterbury**  
**Christchurch, New Zealand**

## **Summary**

An integrated research project on timber-concrete composite (TCC) floors in Australasia comprises of four primary objectives involving the University of Technology, Sydney; the University of Canterbury, Christchurch; and the University of Sassari, Italy together with several other industry partners. New applications of timber in multi-storey buildings are being sought by the timber industry in both Australia and New Zealand. Current development and testing of medium to long span flooring systems are highlighted. A semi-prefabricated TCC floor system that is economical, practical and easy to construct is proposed and four major phases of extensive investigations for short- and long-term involving full scale T-strip floor beams are described. The experimental results of phase one, short-term monitoring of beams are reported and compared with a uniaxial finite element model which was specially developed for long-term and collapse analysis of TCC beams. Overall, the validations were found to be within good accuracy except for some cases with acceptable experimental deviations. Other parameters observed were different construction variables and type of concrete.

## **1. Introduction**

The timber-concrete composite (TCC) floor is a construction technique which has become quite common in many countries. A concrete slab mechanically connected to its supporting timber joists using either notches cut from the timber or suitable mechanical fasteners enables a number of advantages: (1) retaining the original timber structures and simultaneously increasing its stiffness and strength, (2) developing a rigid floor diaphragm, and (3) enhancing the acoustic separation, thermal mass, and fire resistance of the floor. The materials in TCC are effectively utilised in terms of strength performance where the timber web is mainly subjected to tension and bending, the

concrete flange is mainly subjected to compression, and the connection system subjected to shear. A stiff and strong connection system is crucial in order to achieve a suitable bending strength and stiffness of the TCC. Hence, a minimum relative slip between the bottom fibre of the concrete slab and the top fibre of the timber beam, and a high composite efficiency are necessary to be achieved.

The timber industry in both New Zealand and Australia is currently looking for new applications of timber in multi-storey buildings. The effort is to venture into the possibility to produce medium to long-span TCC floors of 8 to 10 m using laminated veneer lumber (LVL). There is currently an extensive research programme ongoing at the University of Canterbury in collaboration with the University of Technology, Sydney and University of Sassari, Italy, aimed to develop such a system. The research involves tests to failure and long-term tests of full scale concrete-LVL composite beams and different connection details, dynamic vibration tests of composite beams, and tests under repeated loads of composite beams and different connection details. This paper reports the first outcomes of the short-term experimental tests performed on the TCC floor strips which is a continuing phase after some extensive push-out connection investigations. The mid-span deflection of the TCC floor strips for propped and unpropped construction methods over one month is compared to a finite element model. An overview of the collaborative works at the University of Technology, Sydney is also reported together with the proposed semi-prefabricated composite system.

## **2. Project Brief on Innovative Engineered Timber Building Systems for Non-Residential Applications**

A number of recent studies undertaken in Australia and New Zealand have highlighted the lack of timber usage in the non-residential building sector, whilst at the same time identifying that there are significant opportunities with the potential to improve market share for the timber industry in medium rise commercial and multi-residential buildings up to 8 stories in height.

However, a number of specific obstacles need to be addressed in order to realise this potential – a major one being the need to develop structural systems that can take advantage of prefabrication manufacture, embody Environmentally Sustainable Design (ESD) principles, are commercially competitive to construct and meet the relevant performance criteria (e.g. structural, occupational safety and comfort, fire and durability) for non residential buildings.

In 2007, the Forest and Wood Products Association of Australia funded a research and development project (2 years - total \$630k AUD) that represents a first step in developing efficient and innovative structural systems that utilise timber and provide a competitive alternative to steel and concrete products, which currently dominate building solutions in the non residential market sector in Australia and New Zealand.

The research team is a partnership of key staff from the University of Technology, Sydney; the University of Canterbury, Christchurch; the University of Sassari, Italy; Timberbuilt P/L and Carter Holt Harvey (FutureBuild). It is anticipated that other industry partners will join the research team at some future time. In developing the scope for the project, several primary objectives have been defined:

- 1) Identification and development of at least 3 flooring concepts suitable for use in a multi-storey commercial building, which meet the project objectives.
- 2) Testing of Prototype details to validate theoretical models used to simulate the performance of the structural concepts from (1) focusing on timber-concrete composite flooring systems spanning up to 10m. This paper describes the current development and testing of these flooring systems.
- 3) Development of the structural concepts into specific “solutions” to ensure that the systems have superior environmental performance (process and embodied energy / CO<sub>2</sub> emissions) and ESD "value" compared to steel and reinforced concrete alternatives, whilst meeting both occupational (vibration, acoustic and thermal) and safety (loading and fire) requirements.
- 4) Production of a “virtual” prototype building based on the whole of building structural solutions and relevant documentation to demonstrate proof of concept and support proposals for future stages of testing and development.

It is hoped that this project will form an integral part of a much larger project dealing with all aspects of multi-storey timber commercial buildings that is planned to commence later in 2008.

### 3. Semi-Prefabricated TCC Floor System

The key component of a multi-storey timber building is the floor system. Pertinent performance requirements includes: (1) resistance to gravity load (strength limit state for out-of-plane loading), (2) control of vibration and deflection due to gravity load (serviceability limit state), (3) resistance to lateral load (strength limit state for in-plane loading), (4) control of deflection due to lateral load on the diaphragm (strength and serviceability limit state), (5) fire resistance, (6) acoustic separation, and (7) thermal insulation.

Traditional joist floors are extensively used for single- or two-storey houses [1]. Such flooring is constructed from particleboard or plywood nailed on timber joists and blocking. The system is light, easy to construct and inexpensive, however it does not fulfil all of the aforementioned performance requirements especially in terms of deflection and vibration for medium to long spans (5 to 10 m), and acoustic separation. Such disadvantages have over the years resulted in the investigation and introduction of different innovative systems in several parts of the world, such as the stressed skin panels in Australia [2] and Europe [3], cross-laminated timber in Europe [4], and timber-concrete composite (TCC) floors in Europe [5] and here in Australasia [6].

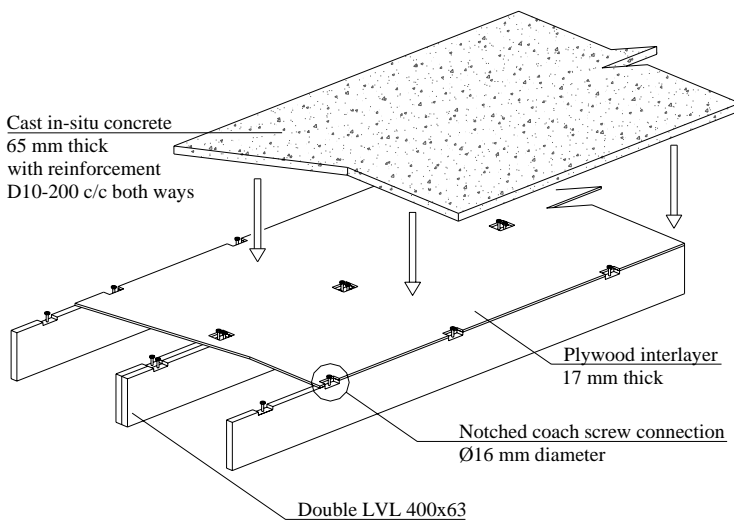

Fig. 1 Proposed semi-prefabricated TCC floor system

Several important advantages of TCC systems can be highlighted: (1) reduced self weight compared to precast concrete floor, (2) better acoustic performance compared to timber-only floors, and (3) ability to span 6 to 10m with minimum deflection as a result of high stiffness contributed by concrete topping. A semi-prefabricated floor system is currently under investigation at the University of Canterbury (Fig. 1). The feature of this solution for multi-storey timber building is the prefabrication, ease of transport and erection due to the low self-weight. The crucial component is the connection system, which must be strong, stiff and economical. Based on a pilot



Fig. 2 Notched coach screw connection detail

study [6,7], the notched detail was selected as the strongest and stiffest type of connection for TCC floors (Fig. 2). In this type of connection, the shear forces are transferred from concrete to LVL through bearing at the interface between the two materials in the notch. The use of a coach screw in the notch has the additional benefit of improving the post-peak behaviour [7].

The 2400 mm wide “M” section panel is built with a single 400 × 63 mm LVL joist on each outer edge and a double LVL joist in the centre (Fig. 3). A plywood interlayer is nailed on the top of the LVL joists to provide a permanent formwork for the concrete. Steel mesh is laid above the panels to provide shrinkage control for a 65 mm thick cast in-situ concrete slab. The panels can be propped while the concrete cures. The notches are cut from the LVL joists before the plywood interlayer is nailed on.

The span of between 8 and 10 m requires 6 to 8 connectors along the length of each joist to provide adequate composite action. Each panel weighs approximately 8 kN, resulting in a lightweight component that is easy to transport and crane. Each panel is either placed directly onto the beams of the gravity resisting frame or hung from them using proprietary steel hangers. The prefabricated panels are placed side by side and connected using either screws or nails (Fig. 3), with the concrete

slab poured thereafter. The design is based on the effective bending stiffness method (the so-called “ $\gamma$ -method”) as recommended by Ceccotti [5] in accordance with the Eurocode 5 [8]. A detailed worked example can be found in [9].

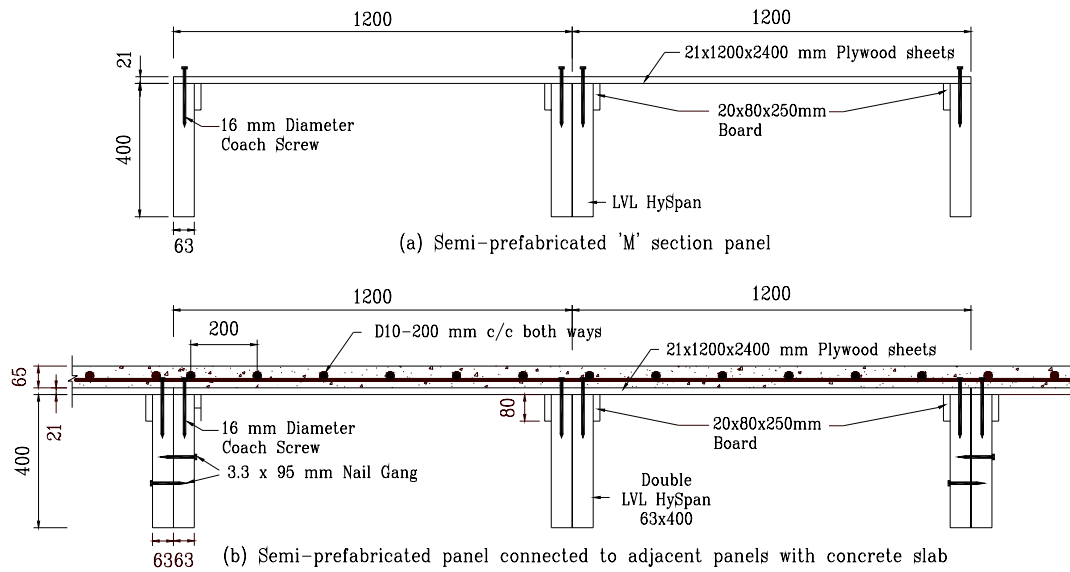

Fig. 3 Semi-prefabricated “M” section panel (dimensions in mm)

#### 4. TCC Experimental Programme

An extensive experimental programme on a full-scale T-strip of TCC floor spanning 8 and 10 m is currently in progress at the University of Canterbury which involves 4 phases: (1) short-term monitoring of beams outdoor and indoor, in unconditioned environment, where the deflections and strains of 9 beams have been monitored for a period of 1 month after the concrete placement to investigate the effects of the construction process and the environmental changes; (2) short-term monitoring of beams indoor in unconditioned environment, where 4 beams are being monitored for a period of 3 months with the service load applied after 28 days from the concrete placement in order to investigate the time-dependent behaviour during construction and the first months of life of the structure; (3) repeated loading of selected beams and test to failure of all the beams in (1) and (2) under four-point bending static load; and (4) long-term monitoring of 3 beams under service load for a period of 1 year and then unloaded for 3 months to assess the creep coefficient during loading and unloading periods.

The four most promising types of connectors for the beam specimens were identified using the push-out tests [8]. Different numbers of connectors corresponding to two scenarios, well-designed and under-designed according to the Eurocode 5 provisions, have been considered for each type of connection. The gamma ( $\gamma$ ) method was adopted for the design of the beams at ultimate limit state and serviceability limit state, with the slip moduli and strength values obtained from push-out tests.

All the beams have been designed and constructed by varying a number of parameters: (1) the type of connection, (2) the number of connectors, (3) the span length, (4) the type of construction, and (5) the type of concrete. Two span lengths were tested: 8 m and 10 m. Construction variables include the number of days of mid-span propping (0, 7 and 14) and curing (1 and 5), and whether the notches are cast at the time of the concrete placement or grouted 7 days later. The grouted notches required a void or pocket at the time of concrete placement that will be filled later with high strength grout with shrinkage compensation. The type of concrete was carefully selected as shrinkage is expected to induce significant deflection on the TCC beam due to the high stiffness of the connection. The concrete selected is a commercially available low shrinkage concrete (CLSC) of 35 MPa, 650 microstrain with special admixture (Eclipse), 13 mm size aggregate and 120 mm slump.

#### 5. First Month Monitoring of Beams

This section reports the first phase of the aforementioned extensive research programme. 5 beams were constructed outdoor while another 4 beams both constructed indoor. The deflections and strains at

mid-span were monitored for all the beams during the first month after the concrete placement (Table 1). Each beam varies in terms of connection type, number of connections along span, use of propping at mid-span, concrete type and level of design. Fig. 4 displays a typical 8 m TCC T-strip beam with a 300 mm length rectangular notched connection. The aims of this short-term test are to investigate the effects of environmental changes and type of construction, and compared the experimental results with a purposely developed uniaxial finite element model.

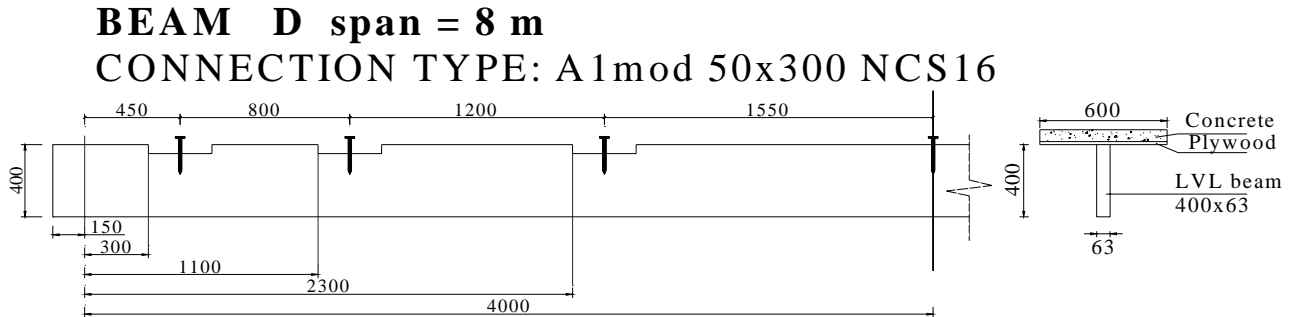

Fig. 4 A typical 8 m TCC T-strip beam with a 300 mm length rectangular notched connection

Deflection and strains of LVL at mid-span were recorded using potentiometer and strain gauges respectively, every five minute during concrete casting and subsequently every hour after the concrete has set. The strains on the LVL joist were measured at 3 locations along mid-span: at both side faces and lower fibre of LVL (Fig. 5). Relative humidity and temperature were automatically recorded with 4 key events noted overtime: (1) concrete placement, (2) concrete set, assumed as 6 hours after casting, (3) prop removal, and (4) 28 day.

Table 1 Schedule of Phase 1: short-term 1 month monitoring beams schedule

Beam Notation and (Location)	Connection and (Number of connectors) in mm	Span and (Width) in metre	Propped (Days) or Unpropped	Design level and (Concrete Type)
A1 (Indoor)	25dx150l NCS $\phi$ 16 (6 numbers)	8 (0.60)	Propped (14)	Under-designed (CLSC)
C1 (Outdoor)	30°_60° TriNCS $\phi$ 16 (10 numbers)	8 (0.60)	Propped (7)	Well-designed (CLSC)
D1 (Outdoor)	50dx300l NCS $\phi$ 16 (6 numbers)	8 (0.60)	Propped (7)	Well-designed (CLSC)
D2 (Outdoor)	50dx300l NCS $\phi$ 16 (6 numbers)	8 (0.60)	Unpropped	Well-designed (CLSC)
E1 (Indoor)	50dx300l NCS $\phi$ 16 (6 numbers)	10 (0.60)	Propped (7)	Under-designed (CLSC)
E2 (Indoor)	50dx300l NCS $\phi$ 16 (6 numbers)	10 (0.60)	Propped (7)	Under-designed (NC)
F1 (Outdoor) double LVL	Plate_2x333l Staggered (8 numbers)	8 (1.20)	Propped (7)	Well-designed (CLSC)
F2 (Outdoor) double LVL	Plate_2x333l Staggered (8 numbers)	8 (1.20)	Unpropped	Well-designed (CLSC)
G1 (Indoor) double LVL	2x25dx150l NCS $\phi$ 16 (6 numbers)	8 (1.20)	Propped (7)	Well-designed (CLSC)

Note: NCS - Notched Coach Screw, CLSC - Commercial Low Shrinkage Concrete, NC - Normal Concrete

## 5.1 Finite Element Modelling

A Finite Element (FE) program purposely developed for long-term and collapse analysis of timber-concrete composite beams has been used to model the first part of the long-term tests. The purpose of the numerical modelling was to calibrate the program on the experimental tests, which were performed over a limited period of 28 days, so as at a later stage to extend the results to the end of the service life (50 years) and to composite beams with different mechanical and geometrical properties. The uniaxial FE model is made from two parallel beams, the concrete slab and the

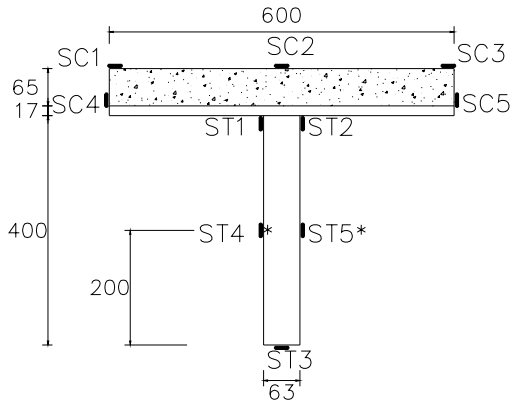

ST for strain gauge for timber LVL  
 SC for strain gauge for concrete in collapse test  
 ST4\* and ST5\* only required for collapse test

**Fig. 5** Strain gauges at mid-span (dimensions in mm)

viscoelastic material, where creep, mechano-sorption, shrinkage/swelling due to temperature and relative humidity variation of the environment, and dependency of the Young's modulus on moisture content can be taken into account using the Toratti's rheological model [11]. Creep and mechano-sorption can also be accounted for in the connection system. The history of moisture content over the timber cross-section affects the timber properties (Young's modulus, mechano-sorption and shrinkage/ swelling) and is calculated by solving the diffusion of moisture content over the timber cross-section in dependence of the history of environmental relative humidity and temperature. More details on the model can be found in literature [12].

The shear force-relative slip relationship obtained from push-out tests and fitted with a power-type function was inputted at the connection locations in the FE model. The concrete cross-section was divided into 20 layers, while the timber cross-section was divided into 80 horizontal layers and 20 vertical columns. The mechanical properties of timber ( $E = 10.7$  GPa) and concrete ( $E = 33$  GPa,  $f_{cm} = 46$  MPa,  $f_{ctm} = 3.4$  MPa) as measured from experimental tests or provided by the manufacturer were used. The actual relative humidity and temperature histories monitored during the tests were inputted to represent the environmental conditions.

## 5.2 Results and Discussions

Fig. 7 reports the experimental-numerical comparisons in terms of mid-span deflection for selected outdoor TCC beams (C1, D1 and D2) under unconditioned environment. Overall, the deflection plot in all the beams throughout the whole monitoring period followed a wave pattern with daily period according to the environmental fluctuations. The peaks of relative humidity (RH) occurred at the times of the minimum daily temperatures. The fluctuation of deflection was found in all plots to be consistent with the peaks of relative humidity and minimum values of temperature. Basically, the deflection fluctuation was within the range of 4 to 6 mm, and took place between day and night.

Deflection of unpropped beam (D2) increased 11 mm at time of casting. Uneven and soft outdoor grounds have caused invalid deflection in propped beams (C1, D1) which had to be corrected. Props were removed after 7 days in propped beams. An instantaneous 6 to 10 mm deflection increment

timber beam, connected at their interface with a continuous spring system which models the connection system and account for its flexibility (Fig. 6).

Kinematic hypotheses are: (1) vertical shear of both parallel beams negligible; (2) no vertical separation (uplift) between the beams; and (3) same rotation of both beams. A non-linear mechanical model which considers concrete cracking, tension stiffening and non-linear behaviour in compression, with an elastic-brittle behaviour of timber in tension and a non-linear shear force-relative slip relationship for the connection can be implemented for the analyses to collapse. The materials can also be considered with their time-dependent behaviour for long-term analyses under constant sustained load. More in detail, concrete can be considered as a viscoelastic material in compression and in tension before cracking, where allowance for creep and drying shrinkage in accordance with the CEB-FIP Model Code 90 [10] and thermal strains can be made. Timber can be modelled as a hydro-

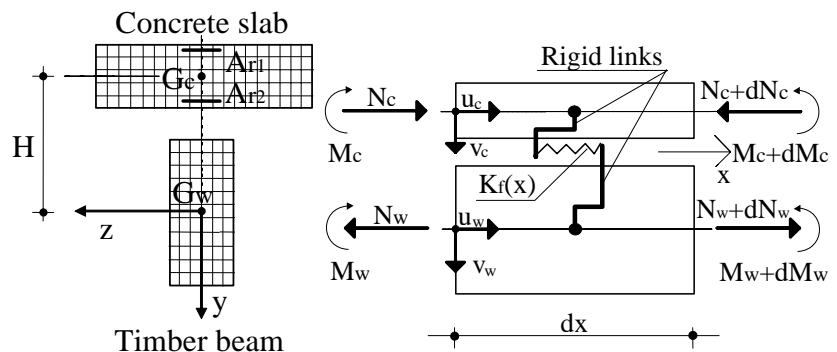

**Fig. 6** Cross-section (left) and elevation (right) of the uniaxial FE model used in the numerical analyses

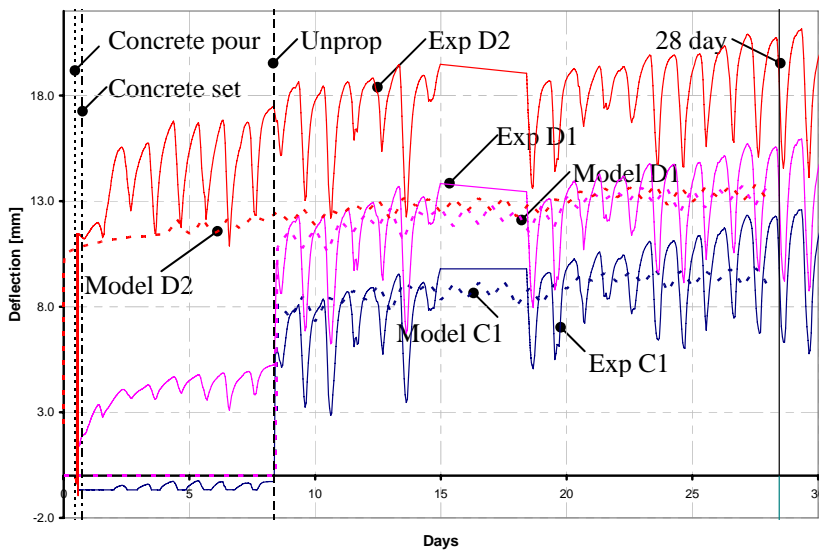
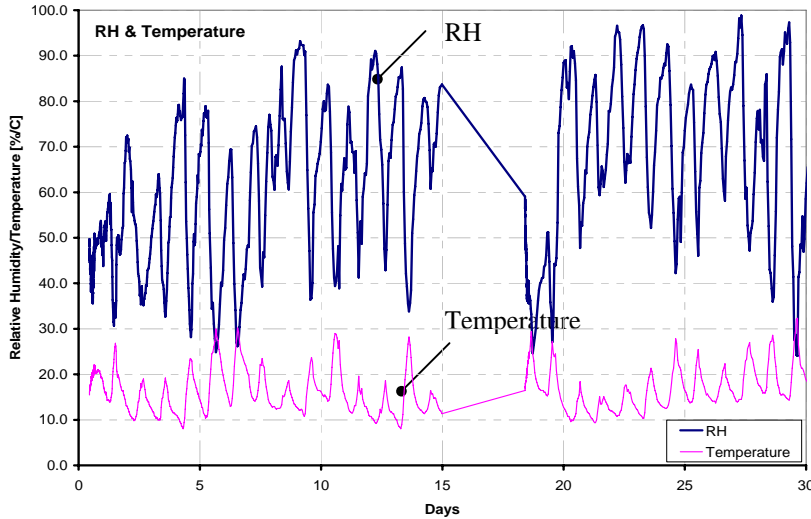

Fig. 7 Experimental-numerical mid-span deflection comparison for outdoor beams (bottom) with corresponding relative humidity and temperature histories

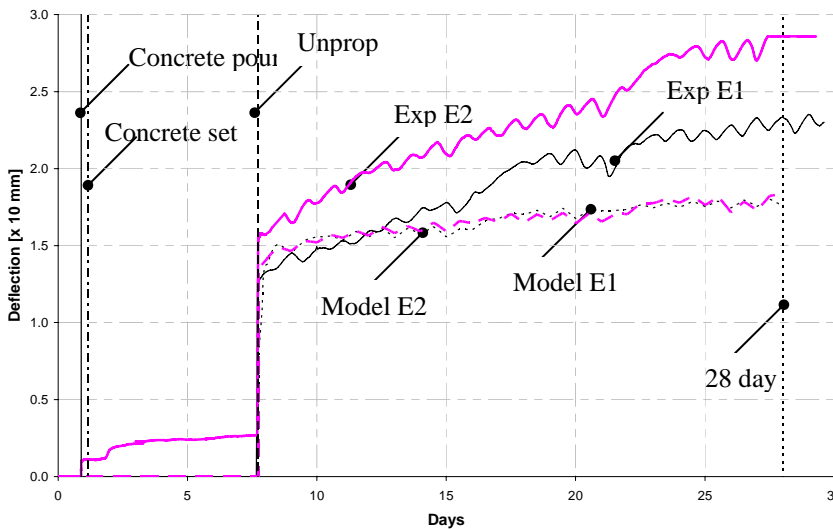

Fig. 8 Experimental-numerical mid-span deflection comparison for indoor beams

was recorded when the prop was removed although the final deflection at 28 day was in the range of 5 mm less than the unpropped beams. On the whole, propping of beams at mid-span was important to minimise permanent deflection and enable initial composite action to be developed before sustaining the full self-weight of the concrete slab. Nevertheless, after the removal of props, deflection fluctuations in all beams follow a similar trend due to RH and temperature changes which were also observed in unpropped beams.

Fig. 8 displays the indoor experimental-numerical comparisons in terms of mid-span deflection for selected TCC beams (E1, E2). The environmental fluctuations were not as prominent as in outdoor conditions and, therefore, the day-to-night deflection variations were insignificant. Low shrinkage concrete (in E1) was effective in reducing the total deflection by 5 mm at 28 day when compared to normal weight concrete (in E2). The concrete shrinkage, in fact, increases the overall deflection of composite beams, especially when the connection is very stiff like in the case under study.

The experimental-numerical comparisons show that the software can capture the experimental results with an overall good accuracy. In general, the deflection differences were less than 10 % for almost all specimens monitored over time. Based on these experimental validations, the software can be used to extend the experimental results to end of the service life (50 years) so as to control the deflection in the long-term, which could be critical for the design of long-span TCC beams.



## 6. Conclusion

In this paper, preliminary results of an extensive experimental programme aimed to develop a TCC floor system for multi-storey building applications were presented. The mid-span deflection of selected TCC beams exposed to indoor and outdoor, unconditioned environment were monitored for a period of 28 days and then compared with a purposely developed numerical model. The primary observations are: (1) Propping of beams at mid-span is crucial to minimise permanent deflection and enable the development of initial sufficient composite stiffness to sustain the full self-weight of the concrete slab; (2) Excessive shrinkage of concrete causes extra deflection, hence low shrinkage concrete is desirable in TCC to minimise any permanent deflection; (3) Extreme environmental fluctuations exert larger deflection variations in composite beams due to the different thermal expansion coefficients of timber and concrete; and (4) The peaks of deflection were consistent with the peaks of environmental relative humidity RH and with the minima of the environmental temperature.

## 7. Acknowledgements

The technical support from Carter Holt Harvey (Mr. Warwick Banks and Mr. Hank Bier), Firth Concrete (Mr. Dene Cook and Mr. Cliff Davis) and MiTek NZ (Mr. Steve Coll and Mr. Antony Cook) is gratefully acknowledged, together with the financial contribution provided by Carter Holt Harvey and by the New Zealand government through the FIDA funds. Thanks to Dr. James Mackechnie for his advice and help with the preparation of the concrete. Special thanks are also due to research assistant, Ms. Marta Mazzilli for her hard work and dedication to this research project.

## 8. References

- [1] Buchanan A.H., *Timber Design Guide* (3rd Edition), New Zealand Timber Industry Federation, Wellington, New Zealand, 2007.
- [2] Gerber C., Crews K., and Sigrist C. "Predicting performance and designing stressed-skin panels - an Australian perspective", 19<sup>th</sup> Australasian Conference on the Mechanics of Structures and Materials, Christchurch, New Zealand, 2006, pp. 1023.
- [3] Raadschelders J.G.M., and Blass H., Stressed skin panels, *Timber Engineering STEP 1*, First Edition, Centrum Hout, The Netherlands, 1995, pp. B10/1-B10/10.
- [4] Ceccotti A., Follesa M., Lauriola M.P., and Sandhaas C., "Which seismic behaviour factor for multi-storey buildings made of cross-laminated wooden panels?" *Proceedings, CIB Working Commission W18-Timber Structures*, Florence (Italy), Paper No. CIB-W18/39-15-4, 2006.
- [5] Ceccotti A., "Timber-concrete composite structures", *Timber Engineering STEP 2*, edited by Hans Blass et al., First Edition, Centrum Hout, The Netherlands, 1995, pp. E13/1-E13/12.
- [6] Deam B.L., Fragiaco M., and Buchanan A.H., "Connections for composite concrete slab and LVL flooring systems", Published online, *Materials and Structures, RILEM*. 2007.
- [7] Yeoh D., Fragiaco M., Aldi P., Mazzilli M., and Kuhlmann U., "Performance of Notched Coach Screw Connection for Timber-Concrete Composite Floor System", *Proceedings, 10<sup>th</sup> World Conference on Timber Engineering 2008*. Miyazaki, Japan, 2008.
- [8] CEN Comité Européen de Normalisation, "*Eurocode 5: Design of timber structures - Part 1.1: General rules and rules for buildings*", EN 1995-1-1, Brussels, Belgium, 2004.
- [9] Fragiaco M., Yeoh D., Davison R., and Banks W., "Chapter 25: Timber Flooring." In: Buchanan, A. *Timber Design Guide*, Wellington: New Zealand Timber Industry Federation Inc., 2007, pp. 275-288.
- [10] Comité Euro-International du Béton, *CEB Bull. No. 213/214: CEB-FIP Model Code 90*, 1993, Lausanne, Switzerland.
- [11] Toratti T., "Creep of timber beams in a variable environment", *Report No. 31*, Helsinki University of Technology, 1992, Helsinki, Finland.
- [12] Fragiaco M., "A finite element model for long-term analysis of timber-concrete composite beams", *Structural Engineering & Mechanics*, Vol. 20, No. 2, 2005, pp. 173-189.



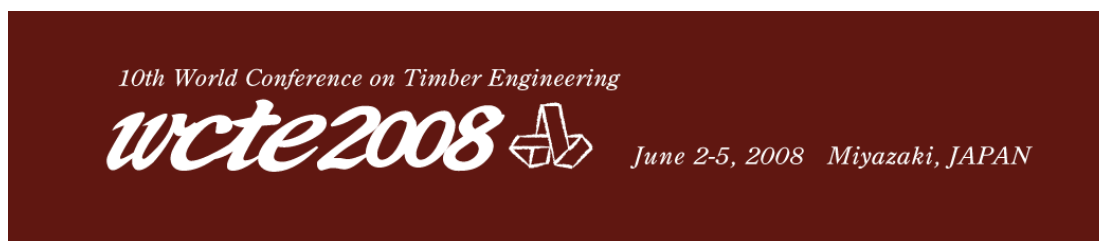

## Welcome to WCTE2008 in Miyazaki,JAPAN

Dear WCTE2008 Delegates,

The World Conference on Timber Engineering showcase the latest technology, innovative design and research relating to the timber engineering field. WCTE is held every two years providing the ultimate forum to exchange information and learn cutting edge technology from leaders in the field of timber engineering worldwide. The participants of the convention include leading architects, engineers, educators, and timber engineering researchers. On the administrative side, the leaders of the convention are respected architects, engineers, educators, timber engineering researchers as well as business leaders in the field of timber engineering and related fields.

There has been a growing movement to utilize biomass, in the face of global warming, a serious shortage and depletion of fossil resources, and the consequent rise in prices. A typical biomass resource is wood. It is a resource converted from carbon dioxide in the atmosphere through photosynthesis of solar energy. This circulating resource returns to carbon dioxide through combustion or biodegradation. Wood species and its uses are remarkably diverse. The most important aspect of wood—renewable or sustainable resources using solar energy—is that human beings commit themselves to their production. The use of wood for timber engineering has direct influence on human life, affecting people involved and producing wider ripple effects on the community and various fields. In other words, its role is driving force and efficiency is not the only measure. We need to take account of forests, which are the place for production, and of the ecological system, in which living creatures co-exist. Deeply concerned with issues of climate and environment, we must be always aware of the need for cooperation in terms of “space” (in same generation) and “time.” (beyond generations).

The 10<sup>th</sup> WCTE Conference 2008 in Miyazaki, Japan received many abstracts and proceedings for presentations with topics of interest spanning the spectrum of the timber engineering field.

We do hope these reports are effective and instructive for mutual understanding between these sectors and will also connect into “the next ones”.

WCTE 2008 Chair  
Dr. Takanori Arima