

## **Editorial**

### **Advanced Mathematical Methods for Collaborative Robotics**

Luis Gracia,<sup>1</sup> Carlos Perez-Vidal,<sup>2</sup> Jaime Valls-Miro,<sup>3</sup>

<sup>1</sup> Instituto de Diseño y Fabricación (IDF), Universitat Politècnica de València, Camino de Vera s/n, Valencia 46022, Spain

<sup>2</sup> Departamento de Ingeniería de Sistemas y Automática (DISA), Universidad Miguel Hernández, Avda de la Universidad s/n, Elche 03202, Spain

<sup>3</sup> Centre for Autonomous Systems (CAS), University of Technology Sydney (UTS), NSW Sydney 2007, Australia

## **1. Introduction**

The distinctive feature of human-robot collaboration is the absence of physical separation between robots and humans, i.e., they work with no safety fencing in the same workstations. This collaboration requires robots equipped with advanced sensors, such as force/torque sensors, vision systems, etc. Moreover, advanced algorithms are needed to provide the robot the level of intelligence required to accomplish the collaborative task at hand. In particular, two topics are especially relevant for human-robot collaboration: robot control using force feedback, and robot guidance. Some literature review is presented below for these topics.

*Robot control using force feedback.* A position/force robot control is presented in [1] using fuzzy techniques for grinding applications. A force overshoot-free method was developed in [2] using impedance control for force tracking. A control technique based on the quarry matrix was proposed in [3] to control the tool pose and the force in the tool Z-axis.

*Robot guidance.* The forces/torques exerted by the operator are usually obtained with a force sensor mounted at the robot wrist and the measurements of the sensor are typically converted into robot motions using compliance control [4]; although other variants and methods can be found in the literature, see [5] [6] among others.

## **2. Control techniques**

One of the fundamental requirements for the success of a human-robot collaboration task is the capacity of the robot system to interact with the human operator. The quantity that describes the state of interaction more effectively is the contact force at the robot's end-effector. High values of contact force are generally undesirable since they produce stress.

To analyze this interaction, it is worth considering the behavior of the system under a position control scheme when contact forces arise. Since these are naturally described in the operational space, it is convenient to refer to operational space control schemes.

The impedance control is convenient to analyze the interaction of a manipulator with the environment under the action of an inverse dynamics control in the operational space. The block scheme representing impedance control is reported in Fig. 1.

The impedance control, in absence of interaction or along the directions of free motion, is equivalent to an inverse dynamics position control. Therefore, for the selection of the impedance parameters, it should be considered the need of high values to reject disturbances due to model uncertainties and to the approximations into the inverse dynamics computation. Such high factors increase proportionally the gain matrix but the interaction forces must be limited to avoid undesired oscillations.

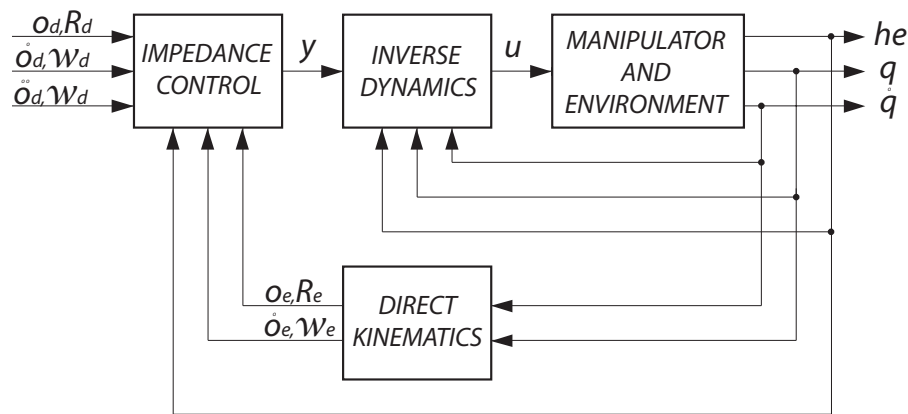

Fig. 1. Block scheme of impedance control

Description of an interaction task between the robot and its environment in terms of natural constraints and artificial constraints, expressed with reference to the constraint frame, suggests a control structure that uses the artificial constraints to specify the objectives of the control system so that, the desired values can be imposed only onto those variables not subject to natural constraints [7]. The control action should not affect those variables constrained by the surface to avoid conflicts between the control and interaction with environment that could lead to undesired oscillations. This type of control structure is called hybrid force/motion control. The definition of artificial constraints involves both force and position/velocity variables. The block scheme of a hybrid force/motion control law is shown in Fig. 2. The

output variables are assumed to be the vector of end-effector forces and the moments of the robot (linear and angular positions and/or velocities).

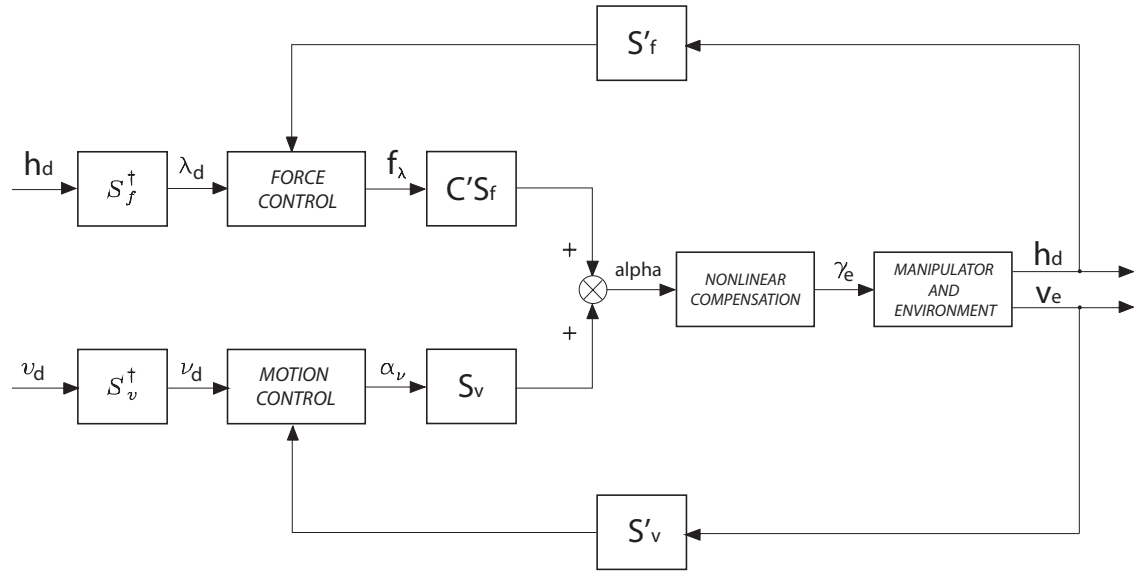

Fig. 2. Block scheme of a hybrid force/motion control for a compliant environment

### 3. Mathematical basis

The kinematics of the robot system is typically considered to properly perform a closed-loop control. In particular, the pose  $p$  and the configuration  $q$  of the robot are related as follows [8]:

$$p = f(q), \quad (1)$$

where  $f$  is the robot kinematic function. The first- and second-order robot kinematics result in:

$$\dot{p} = \frac{\partial f(q)}{\partial q} \dot{q} = J, \quad (2)$$

$$\ddot{p} = J\ddot{q} + \dot{J}\dot{q}, \quad (3)$$

where matrix  $J$  represents the robot Jacobian. Most works tackling robot control assume the existence of low-level joint controllers in charge of achieving the joint accelerations commanded by the designed robot control. Obviously, the robot dynamic model should be considered to design this underlying robot control. Moreover, the bandwidth of the designed control should be slower than that of the low-level joint controllers for stability reasons.

### 4. Description of the Special Issue

This Special Issue on Advanced Mathematical Methods for Collaborative Robotics is focused on Robotics in general and Collaborative Robotics particularly. A total amount of 27 papers were received during the time that the Special Issue was open. After the reviewing process, 11

papers were accepted, that leads an acceptance ratio of 41%. The accepted papers belonged to research centers mainly based in Latin America, Europe and China. A short description of the papers included in this Special Issue is presented below.

D. Li and J. Wang study the position tracking of an electric cylinder, which has internal perturbation, external disturbance, and measurement noise of the output. A control method is proposed for achieving high tracking accuracy and tracking velocity for a wheel-legged robot application. E. Guerra et al. present a multimodal sensory array to accurately positioning an aerial multicopter drones with respect to pipes. A solution based on vision sensors has been proposed. A new method to explore unknown areas, by using a scene-partitioning scheme and assigning weights to the frontiers between explored and unknown areas is presented by J.J. Lopez-Perez et al. An algorithm based on free segments and a turning point strategy for solving the problem of robot path planning in a static environment is presented by I. Hassani et al. The work presented by A. Ferjani et al., deals with the design problem of a robust observer-based controller for a motorcycle system. The nonlinear motorcycle model is firstly modeled and then an observer-based  $H^\infty$  robust controller is designed. Meanwhile the work by J. Liu et al. is devoted to the consensus problems for a fractional-order multiagent system with double integral and time delay. The optimal control of joint pitch angles in the process of a snake robot is tackled by Y. Bai and Y.B. Hou. Many multiagent systems cannot be described by an integer-order dynamical model and can only be described by a fractional-order dynamical model. This is the case of the work presented by J. Liu et al. A biologically-inspired motion control method is introduced by X. Zhang et al. to ameliorate the flexibility and multi-joint autonomy of assistive walking devices based on human–robot interactions. Z. Li et al. study the robust consensus for nonlinear multi-agent systems with uncertainty and disturbance. Finally, a multicriteria optimization is designed by Y. He et al. for end effector mounting bracket of a high speed and heavy load palletizing robot.

### **Acknowledgments**

We want to thank all authors and reviewers for their valuable work to disseminate and curate the information that is content in this special issue.

Luis Gracia  
Carlos Perez-Vidal  
Jaime Valls-Miro

## References

- [1] Xie X, Sun L. Force control based robotic grinding system and application. 2016 12th World Congress on Intelligent Control and Automation (WCICA). 2016. p. 2552–5.
- [2] Roveda L, Vicentini F, Pedrocchi N, Tosatti LM. Impedance control based force- tracking algorithm for interaction robotics tasks: An analytically force overshoots- free approach. 2015 12th International Conference on Informatics in Control, Automation and Robotics (ICINCO). 02. 2015. p. 386–91.
- [3] Kakinuma Y, Igarashi K, Katsura S, Aoyama T. Development of 5-axis polishing machine capable of simultaneous trajectory, posture, and force control. *CIRP Annals - Manufacturing Technology* 2013;62(1):379–82.
- [4] Khan, A. M., Yun, D.-W., Zuhair, K. M., Iqbal, J., Yan, R.-J., Khan, F., & Han, C. (2017). Estimation of desired motion intention and compliance control for upper limb assist ex-oskeleton. *International Journal of Control, Automation and Systems*, 15(2), 802–814.
- [5] Li, Y., & Ge, S. S. (2016). Force tracking control for motion synchronization in human-robot collaboration. *Robotica*, 34(6), 1260–1281.
- [6] Vogel, J., Haddadin, S., Jarosiewicz, B., Simeral, J., Bacher, D., Hochberg, L., van der Smagt, P. (2015). An assistive decision-and-control architecture for force-sensitive hand- arm systems driven by human-machine interfaces. *The International Journal of Robotics Research*, 34(6), 763-780.
- [7] Siciliano, B., Sciavicco, L., Villani, L., Oriolo, G. *Robotics. Modelling, Planning and Control*. Springer. ISBN 978-1-84628-642-1
- [8] Chiaverini, S., Oriolo, G., & Walker, I. (2008). *Kinematically redundant manipulators*. Springer Handbook of Robotics, 245-268.