

Received September 2, 2019, accepted September 17, 2019, date of publication September 19, 2019, date of current version October 2, 2019.

Digital Object Identifier 10.1109/ACCESS.2019.2942412

# Integer Programming Modeling on Group Decision Making With Incomplete Hesitant Fuzzy Linguistic Preference Relations

PENG WU<sup>1</sup>, HONGYAN LI<sup>1,2</sup>, JOSÉ M. MERIGÓ<sup>3</sup>, AND LIGANG ZHOU<sup>1,4</sup>, (Member, IEEE)

<sup>1</sup>School of Mathematical Sciences, Anhui University, Hefei 230601, China

<sup>2</sup>Department of Civil Engineering, Anhui Communications Vocational and Technical College, Hefei 230051, China

<sup>3</sup>Department of Management Control and Information Systems, School of Economics and Business, University of Chile, Santiago 1058, Chile

<sup>4</sup>China Institute of Manufacturing Development, Nanjing University of Information Science and Technology, Nanjing 210044, China

Corresponding author: Ligang Zhou (shuiqiaozlg@126.com)

This work was supported in part by the National Natural Science Foundation of China under Grant 71771001, Grant 71701001, Grant 71501002, and Grant 71871001, in part by the Natural Science Foundation for Distinguished Young Scholars of Anhui Province under Grant 1908085J03, in part by the Research Funding Project of Academic and Technical Leaders and Reserve Candidates in Anhui Province under Grant 2018H179, and in part by the College Excellent Youth Talent Support Program under Grant gxyq2019236.

**ABSTRACT** Complementing missing information and priority vector are of significance important aspects in group decision making (GDM) with incomplete hesitant fuzzy linguistic preference relations (HFLPRs). In this paper, an integer programming model is developed based on additive consistency to estimate missing values of incomplete HFLPRs by using additive consistency. Once the missing values are complemented, a mixed 0-1 programming model is established to derive the priority vectors from complete HFLPRs, in which the underlying idea of the mixed 0-1 programming model is the probability sampling in statistics and minimum deviation between the priority vector and HFLPR. In addition, we also propose a new GDM approach for incomplete HFLPRs by integrating the integer programming model and the mixed 0-1 programming model. Finally, two case studies and comparative analysis detail the application of the proposed models.

**INDEX TERMS** Group decision making, incomplete hesitant fuzzy linguistic preference relation, probability sampling, mathematical programming, priority vector.

## I. INTRODUCTION

Group decision making (GDM) is to determine the optimal alternative(s) from a given set of alternatives by a group decision makers (DMs). Preference relation as a useful and popular tool to solve GDM problems has received considerable attention. In recent years, various preference relations in GDM have been investigated, including multiplicative preference relation [1], fuzzy preference relation [2], interval multiplicative preference relation [3], interval fuzzy preference relation [4], triangular fuzzy preference relation [5], trapezoidal fuzzy preference relation [6], [7], intuitionistic fuzzy preference relation [8] and hesitant fuzzy preference relation [9].

However, owing to the DMs may be lack of knowledge and limited expertise, they may provide incomplete preference

The associate editor coordinating the review of this manuscript and approving it for publication was Chun-Hao Chen<sup>1</sup>.

information. It means that the DMs may give their preferences with incomplete preference relations (IPRs) in which some elements are missing. Much work of IPRs is summarized in two aspects as follows.

### A. COMPLEMENTING MISSING ELEMENTS OF IPRs

Xu [10] first defined the concept of an incomplete multiplicative linguistic preference relation and developed an algorithm to complement the missing elements of incomplete multiplicative linguistic preference relation. Liu *et al.* [11] proposed a goal programming model for complementing missing values of incomplete interval multiplicative preference relations (IMPRs). For incomplete linguistic preference relations, Zhao *et al.* [12] established a goal programming model to estimate the missing values. Meng and Chen [13] presented a goal programming model for complementing the missing values in incomplete fuzzy preference relations. Wang and Zhang [14] defined the geometric consistency of

incomplete intuitionistic preference relations and proposed two goal programming models to evaluate missing values of an incomplete intuitionistic preference relation. For incomplete multiplicative preference relations, Meng and Chen [15] proposed a linear programming model to estimate the missing values based on geometric consistency index. Xu *et al.* [16] presented two procedures for estimating missing values of incomplete interval fuzzy preference relations. Wang and Xu [17] developed an interactive algorithm to complement missing values of incomplete linguistic preference relation based on consistency measure.

### B. DERIVING PRIORITY VECTOR FROM IPRs

To obtain the priority vector of incomplete IMPR, Liu *et al.* [11] proposed an algorithm whose core is to convert the incomplete IMPR into complete IMPR. Xu [18] defined the original concept of an incomplete fuzzy preference relation and proposed two goal programming models to derive the priority vector from incomplete fuzzy preference relation. Based on the concept of incomplete fuzzy preference relation, Gong [19] developed a least-square method to obtain the priority vector and Xu *et al.* [20], [21] presented a chi-square method and a least deviation method for obtaining the priority vector from incomplete fuzzy preference relation. Zhang and Guo [22] constructed a bi-objective optimization model based on the minimum deviation between group consensus and the individual consistency for obtaining priority vectors from heterogeneous incomplete uncertain preference relations. Zhang [23] first defined the concept of incomplete hesitant fuzzy preference relation (HFPR) and established a goal programming model for deriving the priority vector from an incomplete HFPR. Xu *et al.* [24] proposed two goal programming models to derive the priority vector from an incomplete HFPR based on multiplicative consistency and additive consistency, respectively. Xu and Wang [25] developed an eigenvector method for obtaining priority vector from an incomplete fuzzy preference relation. Zhang *et al.* [26] proposed an approach to deriving a priority vector from an incomplete HFPR by using the logarithmic least squares method.

For an overview of incomplete preference relations, please see [27]. However, in the decision making process, preferences provided by DMs are typically given in the form of hesitant fuzzy linguistic term sets (HFLTSSs) [28] to express their qualitative and hesitant preference information. Since HFLTSSs appearance, plenty of methods with HFLTSSs have been developed [29]–[36] and they have been used to deal with many practical problems, including fire rescue plans selection [37], nature disaster risk evaluation [38], meteorological disaster risk assessment [40], used-car management in a lemon market [41], reliability allocation [42], selection of mining methods for lead-zinc mine [43].

In recent years, the hesitant fuzzy linguistic preference relation (HFLPR) as a new preference structure has been intensively investigated [40], [44]–[48], [66], [67]. However, DMs may sometimes be unsure, uninterested in some

comparative judgments, or unwilling to express their opinions on some sensitive issues. In this decision environment, preference information may be missed in HFLPR. Namely, DMs provide their preference information using incomplete HFLPRs. For decision making problem with incomplete HFLPRs, Tang *et al.* [38] first defined the concept of incomplete HFLPRs and investigated three procedures to evaluate missing values in incomplete HFLPRs. Furthermore, an approach for GDM with incomplete HFLPRs was developed. Liu *et al.* [58] developed several optimization approaches to complement missing elements of incomplete HFLPR, and introduced an consistency improving algorithm to revise the consistency level of HFLPR. Song and Hu [65] presented a GDM model based on fuzzy linear programming for incomplete comparative expressions with hesitant linguistic terms (HFLPR in the sense of this paper). It does not need to estimate missing elements.

Up to now, there are few investigations for addressing the incomplete HFLPRs, which are a convenient way to DMs. Previous studies have enriched the research on GDM with incomplete HFLPRs. However, there are still some limitations:

- The complementing method in [38] may provide some virtual linguistic terms as complemented preferences. Meanwhile, they do not conform to the definition of HFLTSS. Because of the characteristics of the completion algorithm developed by [58], the complementing information may be the whole linguistic term set, which is inconsistent with human cognition.
- In GDM process, collective preference relation is the aggregation of preferences given by all DMs. It represents to the preference opinions of all DMs. However, there is no hesitation in the collective preference relation provided by [58], [65]. Therefore, the way that complete HFLPR or incomplete HFLPR is transformed into fuzzy LPR may cause loss of original hesitant fuzzy linguistic information.

Herrera-Viedma *et al.* [39] have pointed “When measuring the consistency level of an incomplete preference relation, the completeness should be considered”. It is very meaningful to study the method of complementing missing elements of incomplete HFLPR. Motivation by these, this paper develops two optimization models for dealing with incomplete HFLPR. One is used to complement the missing values of incomplete HFLPR, the other is utilized to obtain priority vector from complete HFLPR. The novelties of this paper are as follows:

- Based on the additive consistency of HFLPR, an integer linear programming model is proposed to obtain complete HFLPRs from incomplete HFLPRs by estimating the missing values of incomplete HFLPRs. The integer linear programming model can guarantee the complementing preference values are not virtual linguistic terms. It means that they belong to original evaluation linguistic term set. It is closer to the preferences of DMs in the decision making process.

- When the incomplete information is complemented, a mixed 0-1 programming model is constructed to obtain priority vectors of complete HFLPRs based on the probability sampling in statistics and minimum deviation between the priority vector and complete HFLPR.
- A GDM method with incomplete HFLPRs is presented by integrating an integer linear programming model and a mixed 0-1 programming model.

It should be pointed out that this paper proposes a method for GDM with incomplete HFLPRs by combining completion method and the priority vector. The advantage of this is that it is not limited to the study of the completion method and the priority vector separately, but the combination further enriches the GDM method under incomplete HFLPRs environment.

The rest of the paper is structured as follows. Section II reviews some preliminaries. Section III presents an integer linear programming model to evaluate missing values of incomplete HFLPRs. Section IV proposes a mixed 0-1 programming model for deriving priority vector form complete HFLPRs. In Section V, two case studies are given to show the efficiency of the proposed method, some comparative analysis and advantages of the proposed method are also discussed. In section VI, we conclude the paper by summarizing the main conclusions of the paper.

## II. PRELIMINARIES

Some preliminaries of HFLTSs, hesitant fuzzy linguistic preference relation (HFLPR), incomplete HFLPR are reviewed in this section.

### A. HESITANT FUZZY LINGUISTIC TERM SETS

Let  $S = \{s_l | l = 0, 1, \dots, g\}$  be a finite and totally ordered discrete linguistic term set with odd granularity  $g + 1$  in which the additive linguistic label satisfies the following properties [62]:

- (1) Ordered property: if  $i \geq j$ , then  $s_i \geq s_j$ ;
- (2) Negation operator:  $neg(s_l) = s_{g-l}$ .

For convenience, supposing that  $s_l \in S$ ,  $I(s_l)$  denotes the lower index of linguistic variable  $s_l$ , then we have  $I(s_l) = l$ .

The 2-tuple linguistic model, as a new linguistic representation form, was presented by Herrera and Martínez [55]. It represents the linguistic information using a 2-tuple  $(s_l, \alpha)$  in which  $s_l \in S$  and  $\alpha \in [-0.5, 0.5)$ . Let  $S$  be as before and  $\beta \in [0, g]$  be a value representing the result of a symbolic aggregation operation. There is a mapping between 2-tuple and  $\beta$ :  $\Delta : [0, g] \rightarrow S \times [-0.5, 0.5)$ , where  $\Delta(\beta) = (s_l, \alpha)$  with  $\begin{cases} s_l, l = round(\beta) \\ \alpha = \beta - l, \alpha \in [-0.5, 0.5) \end{cases}$ .

Conversely, there is a function  $\Delta^{-1} : (s_l, \alpha) \rightarrow [0, g]$  is defined as  $\Delta^{-1}(s_l, \alpha) = l + \alpha$ . In particular, if  $\alpha = 0$ , then  $(s_l, \alpha)$  degenerates into a simple linguistic term  $s_l$ .

Redríguez et al. [28] originally defined HFLTS by combining hesitant fuzzy set with fuzzy linguistic approach, which is defined as follows.

*Definition 1 [28]:* Let  $S = \{s_0, s_1, \dots, s_g\}$  be a linguistic term set, then HFLTS  $H_S$  is an ordered finite subset of the consecutive linguistic terms of  $S$ .

For simplicity, in the following, we take  $\mathbb{H}_S$  as the set of all HFLTSs on  $S$ .

*Definition 2 [63]:* Let  $S$  be a linguistic term and  $H_S$  be a HFLTS on  $S$ ,  $\{s_{g-l} | s_l \in H_S\}$  is the negation of  $H_S$ , denoted by  $neg(H_S)$ .

### B. LINGUISTIC PREFERENCE RELATION AND ITS PRIORITY VECTOR

Let  $X = \{x_1, x_2, \dots, x_n\}$  be a finite set of alternatives. When a DM makes pairwise comparisons by using the linguistic term set  $S$ , he/she can express his/her opinion by linguistic preference relation (LPR) on  $X$ . The LPR can be defined as follows:

*Definition 3 [49]:* A LPR on the set  $X$  is characterized by a linguistic decision matrix  $L = (l_{ij})_{n \times n}$ , such that

$$l_{ij} \in S, \quad l_{ij} \oplus l_{ji} = s_g, \quad l_{ii} = s_{\frac{g}{2}}, \quad \forall i, j = 1, 2, \dots, n, \quad (1)$$

where  $l_{ij}$  represents the preference degree of the alternative  $x_i$  over  $x_j$ . Especially,  $l_{ij} = s_{\frac{g}{2}}$  indicates that  $x_i$  is equivalent to  $x_j$ ,  $l_{ij} > s_{\frac{g}{2}}$  indicates that  $x_i$  is preferred to  $x_j$ , and  $l_{ij} < s_{\frac{g}{2}}$  indicates that  $x_j$  is preferred to  $x_i$ .

*Definition 4 [50]:* Let  $L = (l_{ij})_{n \times n}$  be a LPR. If  $L$  satisfies the following condition:

$$I(l_{ij}) + I(l_{jk}) = I(l_{ik}) + \frac{g}{2}, \quad i, j, k = 1, 2, \dots, n, \quad (2)$$

then  $L$  is called a consistent LPR.

For a LPR  $L = (l_{ij})_{n \times n}$ , if there exists a priority vector  $\omega = (\omega_1, \omega_2, \dots, \omega_n)^T$ , which satisfies  $\omega_i \geq 0$  and  $\sum_{i=1}^n \omega_i = 1$ , such that  $I(l_{ij}) = \frac{g}{2}(\omega_i - \omega_j + 1)$ , then  $L$  is consistent. Hence, for an inconsistent LPR  $L$ ,  $I(l_{ij}) \neq \frac{g}{2}(\omega_i - \omega_j + 1)$  holds. Using the deviation between  $I(l_{ij})$  and  $\frac{g}{2}(\omega_i - \omega_j + 1)$ , the optimization model for obtaining the priority vector  $\omega$  was defined by the following model [51]:

$$(M - 1) \min \sum_{i < j}^n \left| \frac{g}{2}(\omega_i - \omega_j + 1) - I(l_{ij}) \right|$$

$$s.t. \begin{cases} \omega_i \geq 0, \\ \sum_{i=1}^n \omega_i = 1, \\ i = 1, \dots, n. \end{cases}$$

### C. HESITANT FUZZY LINGUISTIC PREFERENCE RELATION AND ITS NORMALIZED FORM

Zhu and Xu [45] initially presented the concept of HFLPR based on subscript-symmetric linguistic term set. In [44], Li et al. gave the concept of HFLPR based on the finite and totally ordered discrete linguistic term set  $S$ .

*Definition 5 [44]:* Let  $S$  be as before. A HFLPR based on  $S$  is defined by the matrix  $H = (h_{ij})_{n \times n}$  in which  $h_{ij} \in \mathbb{H}_S$ ,  $neg(h_{ij}) = h_{ji}$  and  $h_{ii} = s_{\frac{g}{2}}$ .





In practical decision making problems, the incomplete HFLPR  $\mathcal{H}^I$  does not satisfy the above characters. Namely, Eq. (7) does not hold. Therefore, we can complement the incomplete HFLPR by relaxing the relations in Eq. (7). That is, one can approximate those in Eq. (7) by minimizing the deviation  $\zeta_{ijk,t}$  where

$$\zeta_{ijk,t} = I(\bar{h}_{ij,t}^I) + I(\bar{h}_{jk,t}^I) - I(\bar{h}_{ik,t}^I) - \frac{g}{2}, \quad (8)$$

for  $t = 1, 2, \dots, \ell_{\bar{h}_{ij}^I}$ , and obtain a nonlinear programming (NP) model:

$$(NP) \min \sum_{i,j,k}^n \sum_{t=1}^{\ell_{\bar{h}_{ij}^I}} |\zeta_{ijk,t}|$$

$$s.t. \begin{cases} \zeta_{ijk,t} = I(\bar{h}_{ij,t}^I) + I(\bar{h}_{jk,t}^I) - I(\bar{h}_{ik,t}^I) - \frac{g}{2}, \\ s_0 \leq \bar{h}_{ij,t}^I \leq \bar{h}_{ij,t+1}^I \leq s_g, \quad i < j, (i,j) \in \Omega_1 \\ s_0 \leq \bar{h}_{ji,t+1}^I \leq \bar{h}_{ji,t}^I \leq s_g, \quad i > j, (i,j) \in \Omega_1 \\ i, j, k = 1, 2, \dots, n. \end{cases}$$

The complemented elements obtained by solving (NP) model are probably virtual linguistic terms. It means that they do not belong to original evaluation linguistic term set  $S = \{s_0, \dots, s_g\}$ . Nevertheless, in a practical setting, it is difficult to convince DMs to consider virtual linguistic terms as their complemented preference opinions. To overcome this drawback, a nonlinear integer programming (NIP) model is constructed as follows:

$$(NIP) \min \sum_{i,j,k}^n \sum_{t=1}^{\ell_{\bar{h}_{ij}^I}} |\zeta_{ijk,t}|$$

$$s.t. \begin{cases} \zeta_{ijk,t} = I(\bar{h}_{ij,t}^I) + I(\bar{h}_{jk,t}^I) - I(\bar{h}_{ik,t}^I) - \frac{g}{2}, \\ s_0 \leq \bar{h}_{ij,t}^I \leq \bar{h}_{ij,t+1}^I \leq s_g, \quad i < j, (i,j) \in \Omega_1 \\ s_0 \leq \bar{h}_{ji,t+1}^I \leq \bar{h}_{ji,t}^I \leq s_g, \quad i > j, (i,j) \in \Omega_1 \\ I(\bar{h}_{ij,t}^I) \in \{0, \dots, g\}, \quad i < j, (i,j) \in \Omega_1 \\ I(\bar{h}_{ji,t}^I) \in \{0, \dots, g\}, \quad i > j, (i,j) \in \Omega_1 \\ i, j, k = 1, 2, \dots, n. \end{cases}$$

In general, it is hard to solve nonlinear programming model than to solve linear programming model. In order to solve (NIP) model, it is transformed into an integer linear programming (ILP) model. The following theorem is apparent.

*Theorem 1:* (NIP) model is equivalent to the following integer linear programming (ILP1) model

$$(ILP1) \min \sum_{i,j,k}^n \sum_{t=1}^{\ell_{\bar{h}_{ij}^I}} (\zeta_{ijk,t}^+ + \zeta_{ijk,t}^-)$$

$$s.t. \begin{cases} \zeta_{ijk,t}^+ - \zeta_{ijk,t}^- = I(\bar{h}_{ij,t}^I) + I(\bar{h}_{jk,t}^I) - I(\bar{h}_{ik,t}^I) - \frac{g}{2}, \\ s_0 \leq \bar{h}_{ij,t}^I \leq \bar{h}_{ij,t+1}^I \leq s_g, \quad i < j, (i,j) \in \Omega_1 \\ s_0 \leq \bar{h}_{ji,t+1}^I \leq \bar{h}_{ji,t}^I \leq s_g, \quad i > j, (i,j) \in \Omega_1 \\ I(\bar{h}_{ij,t}^I) \in \{0, \dots, g\}, \quad i < j, (i,j) \in \Omega_1 \\ I(\bar{h}_{ji,t}^I) \in \{0, \dots, g\}, \quad i > j, (i,j) \in \Omega_1 \\ i, j, k = 1, 2, \dots, n. \end{cases}$$

*Proof:* In (NIP) model, the objective function is non-linear. Hence, we convert the objective function and first constraint of (NIP) model into corresponding linear objective function and constraint. For the (NIP) model, suppose that

$$\zeta_{ijk,t}^+ = \begin{cases} \zeta_{ijk,t}, & \zeta_{ijk,t} \geq 0 \\ 0, & \zeta_{ijk,t} < 0; \end{cases} \quad \zeta_{ijk,t}^- = \begin{cases} 0, & \zeta_{ijk,t} \geq 0 \\ -\zeta_{ijk,t}, & \zeta_{ijk,t} < 0. \end{cases}$$

Then, it follows that

$$|\zeta_{ijk,t}| = \zeta_{ijk,t}^+ + \zeta_{ijk,t}^-, \quad \zeta_{ijk,t} = \zeta_{ijk,t}^+ - \zeta_{ijk,t}^-.$$

Thus, the objective functions of (NIP) model and (ILP1) model are equivalent. Similarity, the first constraint in (NIP) model is equivalent to the first of (ILP1) model. It is found that the (NIP) is equivalent to the (ILP1) model.

In order to further simplify the computations, the (ILP1) model can be simplified by considering the upper diagonal elements of  $\mathcal{H}^I$  as follows:

$$(ILP2) \min \sum_{i < j < k}^n \sum_{t=1}^{\ell_{\bar{h}_{ij}^I}} (\zeta_{ijk,t}^+ + \zeta_{ijk,t}^-)$$

$$s.t. \begin{cases} \zeta_{ijk,t}^+ - \zeta_{ijk,t}^- = I(\bar{h}_{ij,t}^I) + I(\bar{h}_{jk,t}^I) - I(\bar{h}_{ik,t}^I) - \frac{g}{2}, \\ s_0 \leq \bar{h}_{ij,t}^I \leq \bar{h}_{ij,t+1}^I \leq s_g, \quad i < j, (i,j) \in \Omega_1 \\ I(\bar{h}_{ij,t}^I) \in \{0, \dots, g\}, \quad i < j, (i,j) \in \Omega_1 \\ i, j, k = 1, 2, \dots, n. \end{cases}$$

#### IV. A MIXED 0-1 PROGRAMMING MODEL FOR GENERATING THE PRIORITY VECTOR FROM COMPLETE HFLPR

Inspired by [11], in order to derive the priority vector from incomplete HFLPR, the incomplete HFLPR is transformed into complete HFLPR using the (ILP2) model. Then, the priority vector of complete HFLPR is viewed as the priority vector of incomplete HFLPR. Meanwhile, based on the probability sampling in statistics, any HFLPR can be taken as consisting of many LPRs. In line with the above analyses, we want to find the a LPR from complete HFLPR, which has the smallest deviation with the complete HFLPR. Then, the priority vector of the LPR is viewed as HFLPR's priority vector. Next, the basic idea for obtaining the priority vector from incomplete HFLPR is discussed in detail.

For an incomplete HFLPR  $\mathcal{H}^I = (h_{ij}^I)_{n \times n}$ , the (ILP2) model is used to complement  $\mathcal{H}^I$  to  $\bar{H} = (\bar{h}_{ij})_{n \times n}$ . In the light of Definition 6, the set of all the corresponding LPRs of  $\bar{H}$  is denoted by  $\mathbb{L}_{\bar{H}} = \{L = (l_{ij})_{n \times n} | l_{ij} \in \bar{h}_{ij}, l_{ji} = \text{neg}(l_{ij}), i, j = 1, 2, \dots, n\}$ .

For a complete HFLPR  $\bar{H}$  of incomplete HFLPR  $\mathcal{H}^I$ , we have  $\ell_{\bar{h}_{ij}} = \text{lcm}(\ell_{h_{ij}^I} | (i,j) \in \Omega_2, i < j)$  based on Definition 10. Obviously, there are  $\ell_{\bar{h}_{ij}}$  elements in hesitant fuzzy linguistic term  $\bar{h}_{ij} (1 \leq i < j \leq n)$ . Then, there are  $\prod_{i=1}^{n-1} \prod_{j=i+1}^n \ell_{\bar{h}_{ij}}$  LPRs in  $\mathbb{L}_{\bar{H}}$  corresponding to  $\bar{H}$ . For convenience, let  $\ell = \prod_{i=1}^{n-1} \prod_{j=i+1}^n \ell_{\bar{h}_{ij}}$  and all LPRs are denoted as  $L^{(1)} = (l_{ij}^{(1)})_{n \times n}, L^{(2)} = (l_{ij}^{(2)})_{n \times n}, \dots, L^{(\ell)} = (l_{ij}^{(\ell)})_{n \times n}$ , respectively.

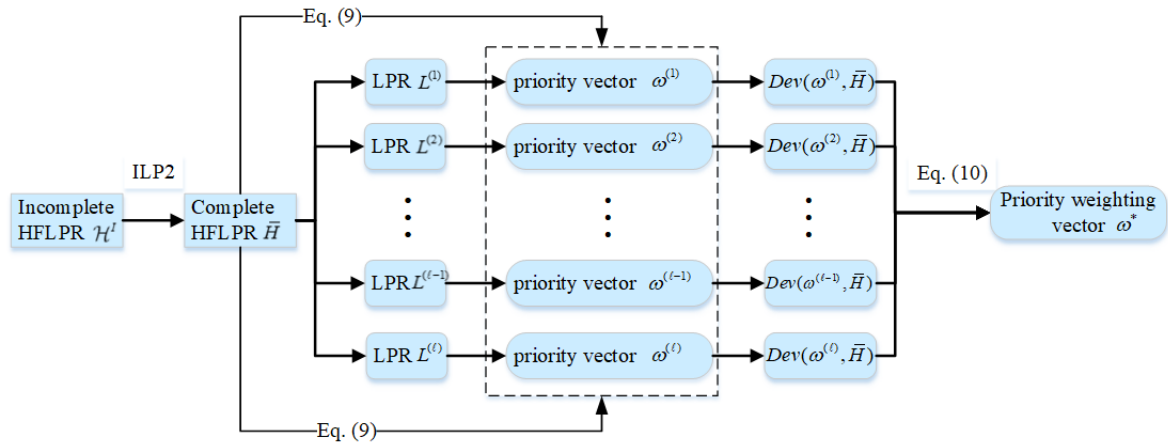

FIGURE 1. The flowchart of deriving priority vector  $\omega^*$ .

For each LPR  $L^{(k)} = (l_{ij}^{(k)})_{n \times n} (k = 1, 2, \dots, \ell)$ , the optimization model (M-1) is utilized to derive the priority vector  $\omega^{(k)} = (\omega_1^{(k)}, \omega_2^{(k)}, \dots, \omega_n^{(k)})$  from  $L^{(k)}$ . The set of priority vectors  $\omega^{(k)}$  of  $L^{(k)}$  corresponding to  $\bar{H}$  can be denoted by  $\Omega_{\bar{H}} = \{\omega^{(k)} | k = 1, 2, \dots, \ell\}$ . Inspired by [26], all the  $\omega^{(k)}$  can be regarded as a possible priority vector of  $\bar{H}$ . To select the best priority vector of  $\bar{H}$ , the following definitions are defined.

**Definition 12:** Let  $\bar{H} = (\bar{h}_{ij})_{n \times n}$  be a complete HFLPR of an incomplete HFLPR  $\mathcal{H}^l = (h_{ij}^l)_{n \times n}$  and  $\omega^{(k)} = (\omega_1^{(k)}, \omega_2^{(k)}, \dots, \omega_n^{(k)}) (k = 1, 2, \dots, \ell)$  be the priority vectors derived from the LPRs of  $\bar{H}$ . Then the deviation between  $\bar{H}$  and  $w^{(k)}$  is defined by

$$Dev(\omega^{(k)}, \bar{H}) = \frac{1}{n} \sum_{i < j} \sum_{l=1}^{\ell_{\bar{h}_{ij}}} \varrho_{ij,l}, \quad (9)$$

in which  $\varrho_{ij,l} = (\frac{\xi}{2}(\omega_i^{(k)} - \omega_j^{(k)} + 1) - I(\bar{h}_{ij}^{\sigma(l)}))^2$ .

Obviously, the  $Dev(\omega^{(k)}, \bar{H})$  reflects the average of total the square deviation between  $\frac{\xi}{2}(\omega_i^{(k)} - \omega_j^{(k)} + 1)$  and  $I(\bar{h}_{ij}^{\sigma(l)})$ . It is natural that the optimal priority vector is the one that minimizes the deviation  $Dev(\omega^{(k)}, \bar{H})$ . Therefore, the priority vector of  $\bar{H}$  can be formally defined as Definition 13.

**Definition 13:** Let  $\mathcal{H}^l, \bar{H}$  and  $\omega^{(k)} = (\omega_1^{(k)}, \omega_2^{(k)}, \dots, \omega_n^{(k)}) (k = 1, 2, \dots, \ell)$  be as before. Then, the priority vector  $\omega^* = (\omega_1^*, \omega_2^*, \dots, \omega_n^*)$  of  $\bar{H}$  is

$$\omega^* = (\omega_1^*, \omega_2^*, \dots, \omega_n^*) = \arg \min_{\omega^{(k)}} Dev(\omega^{(k)}, \bar{H}). \quad (10)$$

Based on the above analyses, the flowchart of deriving priority vector from incomplete HFLPR is shown in Fig. 1.

For an incomplete  $\mathcal{H}^l$ , let  $n$  and  $\ell_{\bar{h}_{ij}}$  be as before. There are  $\ell$  possible LPRs. To obtain the priority vector, model (M-1) and Eq. (9) are computed for  $\prod_{i=1}^{n-1} \prod_{j=i+1}^n \ell_{\bar{h}_{ij}}$  times, respectively. If  $n$  and  $\ell_{\bar{h}_{ij}}$  are large, then the computations of obtaining priority vectors are too onerous. Assume that a

complete HFLPR  $\bar{H}$  listed by:

$$\begin{pmatrix} \{s_4\} & \{s_1, s_2, s_3\} & \{s_6, s_7, s_8\} & \{s_1\} & \{s_5, s_6\} \\ \{s_7, s_6, s_5\} & \{s_4\} & \{s_5, s_6, s_7\} & \{s_1, s_2, s_3\} & \{s_6, s_7\} \\ \{s_2, s_1, s_0\} & \{s_3, s_2, s_1\} & \{s_4\} & \{s_6, s_7\} & \{s_5, s_6\} \\ \{s_7\} & \{s_7, s_6, s_5\} & \{s_2, s_1\} & \{s_4\} & \{s_2, s_3\} \\ \{s_3, s_2\} & \{s_2, s_1\} & \{s_3, s_2\} & \{s_6, s_5\} & \{s_4\} \end{pmatrix}.$$

There are 1296 possible LPRs in  $\mathbb{L}_{\bar{H}}$  of  $\bar{H}$ . Then, the model (M-1) is solved 1296 times to obtain 1296 weighting vectors of possible LPRs. Moreover, the deviation between priority weighting vectors and  $\bar{H}$  is computed 1296 times. In the end, the priority vector is obtained based on Eq. (10). Obviously, to obtain the priority vector, there is huge computations.

Consequently, to overcome the shortcoming of the solving process of priority vector, the 0-1 variables are introduced:

$$\theta_{ij}^{\sigma(l)} = \begin{cases} 0, & \text{if } l_{ij} \neq \bar{h}_{ij}^{\sigma(l)}, \\ 1, & \text{if } l_{ij} = \bar{h}_{ij}^{\sigma(l)}. \end{cases} \quad i, j = 1, 2, \dots, n; l = 1, \dots, \ell_{\bar{h}_{ij}}.$$

Obviously,  $\sum_{l=1}^{\ell_{\bar{h}_{ij}}} \theta_{ij}^{\sigma(l)} = 1$ .

Based on the 0-1 variables, mixed 0-1 programming model (MPM) is developed as:

$$(MPM) \min \sum_{i < j} (\wp_{ij} + \mathfrak{R}_{ij}) \quad s.t. \begin{cases} \sum_{i=1}^n w_i^* = 1, \quad i = 1, 2, \dots, n \\ w_i^* \geq 0, \quad i = 1, 2, \dots, n \\ \sum_{l=1}^{\ell_{\bar{h}_{ij}}} \theta_{ij}^{\sigma(l)} = 1, \\ 1 \leq i < j \leq n; l = 1, 2, \dots, \ell_{\bar{h}_{ij}} \\ \theta_{ij}^{\sigma(l)} \in \{0, 1\}, \\ 1 \leq i < j \leq n; l = 1, 2, \dots, \ell_{\bar{h}_{ij}}. \end{cases}$$

where  $\wp_{ij} = \frac{2}{n(n-1)\ell_{\bar{h}_{ij}}} \sum_{l=1}^{\ell_{\bar{h}_{ij}}} \left( \frac{g}{2}(w_i^* - w_j^* + 1) - I(\bar{h}_{ij}^{\sigma(l)}) \right)^2$  and  $\mathfrak{R}_{ij} = \left| \frac{g}{2}(w_i^* - w_j^* + 1) - \sum_{l=1}^{\ell_{\bar{h}_{ij}}} \theta_{ij}^{\sigma(l)} I(\bar{h}_{ij}^{\sigma(l)}) \right|$ .

The  $\wp_{ij}$  is to guarantee that the minimum distance between  $\omega^*$  and  $\bar{H}$ . Meanwhile,  $\mathfrak{R}_{ij}$  and  $\theta_{ij}^{\sigma(l)}$  guarantee the priority vector  $\omega^*$  derived from  $\mathbb{L}_{\bar{H}}$ .

In what follows, a new approach for dealing with a GDM problem with incomplete HFLPRs is developed as follows:

*Step 1:* Consider a GDM problem with a finite set of alternatives  $X = \{x_1, x_2, \dots, x_n\}$ , a set of DMs  $D = \{d_1, d_2, \dots, d_m\}$  and  $\overline{CI}$  be a predefined consistency threshold. Suppose that the  $z$ th DM provides his/her preferences by using an incomplete HFLPR  $\mathcal{H}_z^l = (h_{ij,z}^l)_{n \times n} (z = 1, 2, \dots, m)$ .

*Step 2:* Obtaining the normalized incomplete HFLPRs  $\bar{\mathcal{H}}_z^l$  using the LCME principle.

*Step 3:* The (ILP2) model is used to complement  $\mathcal{H}_z^l$  to  $\bar{H}_z$ .

*Step 4:* The additive consistency of  $\bar{H}_z = (\bar{h}_{ij,z})_{n \times n} (z = 1, 2, \dots, m)$  is checked by the following eqnarray:

$$CI(\bar{H}_z) = \frac{2}{n(n-1)(n-2)} \frac{1}{\ell_{\bar{h}_{ij}}} \frac{1}{g} \sum_{i < j < k} \sum_{l=1}^{\ell_{\bar{h}_{ij}}} |\mathfrak{S}_{ijk,l}|. \quad (11)$$

where  $\mathfrak{S}_{ijk,l} = I(\bar{h}_{ij,z}^{\sigma(l)}) + I(\bar{h}_{jk,z}^{\sigma(l)}) - I(\bar{h}_{ik,z}^{\sigma(l)}) - \frac{g}{2}$ . If  $CI(\bar{H}_z) \leq \overline{CI}$ , then HFLPR  $\bar{H}_z$  is acceptable additive consistency. Otherwise,  $\bar{H}_z$  is an unacceptable additive consistent HFLPR. For  $\bar{H}_z$  with unacceptable additive consistency, the consistency improving algorithm [52] is implemented to adjust  $\bar{H}_z$  with unacceptable additive consistency into acceptable additive consistency.

*Step 5:* The synthetic HFLPR  $\bar{H}^s = (\bar{h}_{ij}^s)_{n \times n}$  of  $\bar{H}_z$  is obtained by using the following formula [52]:

$$\bar{h}_{ij}^{s,\sigma(l)} = \bigoplus_{z=1}^m v_z \bar{h}_{ij,z}^{\sigma(l)}, \quad l = 1, 2, \dots, \ell_s, \quad (12)$$

where  $\ell_s$  is defined as  $\ell_s = lcm(\ell_{\bar{h}_{1,1}}, \dots, \ell_{\bar{h}_{1,1}}, \dots, \ell_{\bar{h}_{ij,m}})$  by utilizing the LCME principle and  $v = (v_1, v_2, \dots, v_m)^T$  is the priority vector for DMs, which satisfies  $v_z \geq 0$  for  $z = 1, 2, \dots, m$  and  $\sum_{z=1}^m v_z = 1$ .

*Step 6:* Utilizing (MPM), the priority vector  $\omega^*$  of  $\bar{H}^s$  is obtained.

*Step 7:* The alternatives  $x_i (i = 1, 2, \dots, n)$  are ranked in accordance with their priority weights  $\omega_i^*$ .

*Step 8:* Select the best alternative(s) based on the ranking order of  $x_i$ .

*Step 9:* End.

It is worthwhile to point out that the synthetic HFLPR in Step 5 may be represented by different linguistic symbolic models according to Rodríguez and Martínez [56] the 2-tuple fuzzy linguistic model is the most suitable to deal with uncertainty in a fuzzy and accurate way. Hence, in the group's information modelling of the group decision matrix three cases are considered:

- 1) In this case, all information form of the group decision matrix are 2-tuple linguistic terms. In essence, the group decision making matrix is hesitant 2-tuple decision making matrix defined by Wei and Liao [57].
- 2) In this case, all information form of the group decision matrix are HFLTSs. The group decision matrix is group hesitant fuzzy linguistic decision matrix in essence.
- 3) In this case, some forms of information of the group decision matrix are 2-tuple linguistic terms, others are HFLTSs. The group decision matrix is group hybrid information decision matrix in essence.

The above process for GDM with incomplete HFLPRs is depicted in Fig. 2.

## V. CASE STUDY

### A. A CASE OF FLOOD DISASTER RISK EVALUATION

With the change of global climate and social development, the risks of kinds of natural disaster are increasing. A larger number of disasters lead to huge losses of economical properties [53]. Under this background, natural disaster risk reduction management is the most effective and active way for disaster prevention. DMs' knowledge and experience play an important role in disaster risk assessment that is an important tools of risk reduction management. However, owing to the lack of comprehensive information, the DMs may be unable to provide complete judgments when they assess pairwise alternatives.

This section selects flood disaster risk evaluation as the example, which adapted from [38]. Suppose that there are five potentially flooded regions  $R = \{r_1, r_2, r_3, r_4, r_5\}$ . Four DMs  $D = \{d_1, d_2, d_3, d_4\}$  (whose subject weighting vector is  $v = (0.25, 0.25, 0.25, 0.25)^T$ ) are invited to assess the flood disaster risks to make a purposeful precaution. The subject weight vector is determined by some prior information. It is a comprehensive quantity representation that includes DMs' knowledge, experiences, abilities, and expectation. Let  $\overline{CI} = 0.20$ . Because of the lack of knowledge, some information is missing when the DMs compare alternatives. These four DMs provide their incomplete HFLPRs as follows:

$$\mathcal{H}_1^l = \begin{pmatrix} \{s_4\} & x & \{s_3\} & x & x \\ x & \{s_4\} & \{s_5, s_6\} & x & x \\ \{s_5\} & \{s_3, s_2\} & \{s_4\} & \{s_7\} & \{s_5, s_6, s_7\} \\ x & x & \{s_1\} & \{s_4\} & x \\ x & x & \{s_3, s_2, s_1\} & x & \{s_4\} \end{pmatrix},$$

$$\mathcal{H}_2^l = \begin{pmatrix} \{s_4\} & \{s_3\} & \{s_4, s_5\} & \{s_5, s_6, s_7\} & \{s_6, s_7\} \\ \{s_5\} & \{s_4\} & x & x & x \\ \{s_4, s_3\} & x & \{s_4\} & x & x \\ \{s_3, s_2, s_1\} & x & x & \{s_4\} & x \\ \{s_2, s_1\} & x & x & x & \{s_4\} \end{pmatrix},$$

$$\mathcal{H}_3^l = \begin{pmatrix} \{s_4\} & \{s_5, s_6, s_7\} & \{s_7, s_8\} & \{s_5, s_6\} & x \\ \{s_3, s_2, s_1\} & \{s_4\} & \{s_5\} & x & \{s_2, s_3\} \\ \{s_1, s_0\} & \{s_3\} & \{s_4\} & x & \{s_2\} \\ \{s_3, s_2\} & x & x & \{s_4\} & \{s_3, s_4\} \\ x & \{s_6, s_5\} & \{s_6\} & \{s_5, s_4\} & \{s_4\} \end{pmatrix},$$

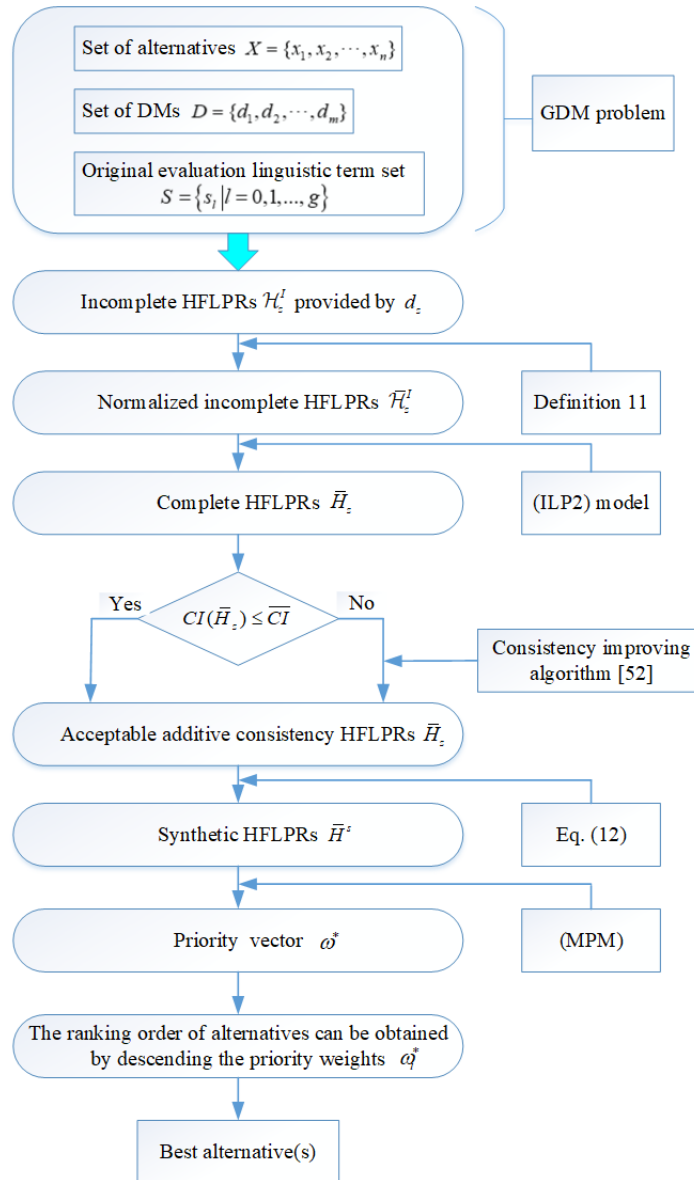

FIGURE 2. The process for GDM with incomplete HFLPRs.

$$\mathcal{H}_4^l = \begin{pmatrix} \{s_4\} & \{s_2\} & \{s_3\} & x & \{s_4, s_5, s_6\} \\ \{s_6\} & \{s_4\} & \{s_4, s_5\} & x & \{s_7, s_8\} \\ \{s_5\} & \{s_4, s_3\} & \{s_4\} & x & \{s_7\} \\ x & x & x & \{s_4\} & x \\ \{s_4, s_3, s_2\} & \{s_1, s_0\} & \{s_1\} & x & \{s_4\} \end{pmatrix}.$$

1) PROCEDURE OF FLOOD DISASTER RISK EVALUATION BASED ON OUR PROPOSED METHOD

It is easy to see that  $\mathcal{H}_1^l, \mathcal{H}_2^l, \mathcal{H}_3^l$  and  $\mathcal{H}_4^l$  are incomplete HFLPRs. Then, the (ILP2) model is utilized to complement the missing information of them. As Step 1 has been provided above, the process of calculation starts from Step 2.

Step 2: By the LCME principle, the normalized incomplete HFLPRs  $\bar{\mathcal{H}}_1^l$  ( $\bar{\mathcal{H}}_z^l, z = 2, 3, 4$  are not listed here because of the space limit) is as below:

$$\bar{\mathcal{H}}_1^l = \begin{pmatrix} \{s_4\} & x & \{s_3\} \\ x & \{s_4\} & \{s_5, s_5, s_5, s_6, s_6, s_6\} \\ \{s_5\} & \{s_3, s_3, s_3, s_2, s_2, s_2\} & \{s_4\} \\ x & x & \{s_1\} \\ x & x & \{s_3, s_3, s_2, s_2, s_1, s_1\} \\ x & x & \\ x & x & \\ \{s_7\} & \{s_5, s_5, s_6, s_5, s_7, s_7\} & \\ \{s_4\} & x & \\ x & \{s_4\} & \end{pmatrix}$$



Step 3: According to the (ILP2) model, one can complete  $\mathcal{H}_z^l(z = 1, 2, 3, 4)$  as follows:

$$\begin{aligned} \bar{H}_1 &= \begin{pmatrix} \{s_4\} & \{s_2, s_2, s_2, s_2, s_2, s_2\} \\ \{s_6, s_6, s_6, s_6, s_6, s_6\} & \{s_4\} \\ \{s_5, s_5, s_5, s_5, s_5, s_5\} & \{s_3, s_3, s_3, s_2, s_2, s_2\} \\ \{s_2, s_2, s_2, s_2, s_2, s_2\} & \{s_0, s_0, s_0, s_0, s_0, s_0\} \\ \{s_4, s_4, s_3, s_3, s_2, s_2\} & \{s_2, s_2, s_1, s_1, s_0, s_0\} \\ & \{s_3, s_3, s_3, s_3, s_3, s_3\} \\ & \{s_5, s_5, s_5, s_6, s_6, s_6\} \\ & \{s_4\} \\ & \{s_1, s_1, s_1, s_1, s_1, s_1\} \\ & \{s_3, s_3, s_2, s_2, s_1, s_1\} \\ & \{s_6, s_6, s_6, s_6, s_6, s_6\} \\ & \{s_4, s_4, s_5, s_5, s_6, s_6\} \\ & \{s_8, s_8, s_8, s_8, s_8, s_8\} \\ & \{s_6, s_6, s_7, s_7, s_8, s_8\} \\ & \{s_7, s_7, s_7, s_7, s_7, s_7\} \\ & \{s_5, s_5, s_6, s_6, s_7, s_7\} \\ & \{s_4\} \\ & \{s_2, s_2, s_3, s_3, s_4, s_4\} \\ & \{s_6, s_6, s_5, s_5, s_4, s_4\} \\ & \{s_4\} \end{pmatrix}, \\ \bar{H}_2 &= \begin{pmatrix} \{s_4\} & \{s_3, s_3, s_3, s_3, s_3, s_3\} \\ \{s_5, s_5, s_5, s_5, s_5, s_5\} & \{s_4\} \\ \{s_4, s_4, s_4, s_3, s_3, s_3\} & \{s_3, s_3, s_3, s_2, s_2, s_2\} \\ \{s_3, s_3, s_2, s_2, s_1, s_1\} & \{s_2, s_2, s_2, s_1, s_1, s_1\} \\ \{s_2, s_2, s_2, s_1, s_1, s_1\} & \{s_1, s_1, s_1, s_0, s_0, s_0\} \\ & \{s_4, s_4, s_4, s_5, s_5, s_5\} \\ & \{s_5, s_5, s_5, s_6, s_6, s_6\} \\ & \{s_4\} \\ & \{s_3, s_3, s_3, s_3, s_3, s_3\} \\ & \{s_2, s_2, s_2, s_2, s_2, s_2\} \\ & \{s_5, s_5, s_6, s_6, s_7, s_7\} \\ & \{s_6, s_6, s_6, s_7, s_7, s_7\} \\ & \{s_7, s_7, s_7, s_8, s_8, s_8\} \\ & \{s_5, s_5, s_5, s_5, s_5, s_5\} \\ & \{s_6, s_6, s_6, s_6, s_6, s_6\} \\ & \{s_4\} \\ & \{s_5, s_5, s_5, s_5, s_5, s_5\} \\ & \{s_3, s_3, s_3, s_3, s_3, s_3\} \\ & \{s_4\} \end{pmatrix}, \\ \bar{H}_3 &= \begin{pmatrix} \{s_4\} & \{s_5, s_5, s_6, s_6, s_7, s_7\} \\ \{s_3, s_3, s_2, s_2, s_1, s_1\} & \{s_4\} \\ \{s_1, s_1, s_1, s_0, s_0, s_0\} & \{s_3, s_3, s_3, s_3, s_3, s_3\} \\ \{s_3, s_3, s_3, s_2, s_2, s_2\} & \{s_6, s_6, s_6, s_5, s_5, s_5\} \\ \{s_4, s_4, s_3, s_3, s_2, s_2\} & \{s_6, s_6, s_6, s_5, s_5, s_5\} \\ & \{s_7, s_7, s_7, s_8, s_8, s_8\} \\ & \{s_5, s_5, s_5, s_5, s_5, s_5\} \\ & \{s_4\} \\ & \{s_6, s_6, s_6, s_6, s_6, s_6\} \\ & \{s_6, s_6, s_6, s_6, s_6, s_6\} \\ & \{s_5, s_5, s_5, s_6, s_6, s_6\} \\ & \{s_4, s_4, s_5, s_6, s_6, s_6\} \\ & \{s_2, s_2, s_2, s_3, s_3, s_3\} \\ & \{s_2, s_2, s_2, s_2, s_2, s_2\} \\ & \{s_2, s_2, s_2, s_2, s_2, s_2\} \\ & \{s_4\} \\ & \{s_3, s_3, s_3, s_4, s_4, s_4\} \\ & \{s_5, s_5, s_5, s_4, s_4, s_4\} \\ & \{s_4\} \end{pmatrix}, \\ \bar{H}_4 &= \begin{pmatrix} \{s_4\} & \{s_2, s_2, s_2, s_2, s_2, s_2\} \\ \{s_6, s_6, s_6, s_6, s_6, s_6\} & \{s_4\} \\ \{s_5, s_5, s_5, s_5, s_5, s_5\} & \{s_4, s_4, s_4, s_3, s_3, s_3\} \\ \{s_6, s_6, s_6, s_5, s_5, s_5\} & \{s_4, s_4, s_4, s_3, s_3, s_3\} \\ \{s_4, s_4, s_3, s_3, s_2, s_2\} & \{s_1, s_1, s_1, s_0, s_0, s_0\} \end{pmatrix}, \end{aligned}$$

$$\begin{pmatrix} \{s_3, s_3, s_3, s_3, s_3, s_3\} \\ \{s_4, s_4, s_4, s_5, s_5, s_5\} \\ \{s_4\} \\ \{s_4, s_4, s_4, s_4, s_4, s_4\} \\ \{s_1, s_1, s_1, s_1, s_1, s_1\} \\ \{s_2, s_2, s_2, s_3, s_3, s_3\} \\ \{s_4, s_4, s_4, s_5, s_5, s_5\} \\ \{s_7, s_7, s_7, s_8, s_8, s_8\} \\ \{s_4\} \\ \{s_7, s_7, s_7, s_7, s_7, s_7\} \\ \{s_4, s_4, s_4, s_4, s_4, s_4\} \\ \{s_7, s_7, s_7, s_7, s_7, s_7\} \\ \{s_1, s_1, s_1, s_1, s_1, s_1\} \\ \{s_4\} \end{pmatrix}.$$

Step 4: By Eq. (11), the additive consistency index of complete HFLPR  $\bar{H}_z(z = 1, 2, 3, 4)$  is calculated as:

$$CI(\bar{H}_1) = 0.0063; CI(\bar{H}_2) = 0.0063; CI(\bar{H}_3) = 0.0174; CI(\bar{H}_4) = 0.0125.$$

It is obvious that  $CI(\bar{H}_z) < \bar{CI} = 0.20, z = 1, 2, 3, 4$ . Namely, all complete HFLPRs are acceptable additive consistency. Therefore, these complete HFLPRs are directly applied to the Step 5.

Step 5: According to Eq. (12), the synthetic HFLPR  $\bar{H}^s$  is, as shown at the top of the next page.

Step 6: Solving (MPM) by LINGO 11, the priority vector  $\omega^*$  of  $\bar{H}^s$  is obtained as:

$$\omega^* = (0.2917, 0.3750, 0.2292, 0.1042, 0)^T.$$

Step 7: The priority weights are ranked in descending order as:

$$w_2^* > w_1^* > w_3^* > w_4^* > w_5^*.$$

Step 8: The alternatives  $r_i(i = 1, 2, 3, 4, 5)$  are ranked in accordance with their priority weights  $w_i^*(i = 1, 2, 3, 4, 5)$  as follows:

$$r_2 > r_1 > r_3 > r_4 > r_5.$$

Therefore, the best alternative is  $r_2$ .

Step 9: End.

## 2) COMPARATIVE ANALYSIS AND DISCUSSION

To verify the ranking result and the effectiveness of the proposed method, the methods proposed in [38] also was used to address incomplete HFLPRs are based on three procedures. By using the approaches [38], the alternatives  $r_i(i = 1, 2, 3, 4, 5)$  are ranked as:  $r_2 > r_1 > r_3 > r_5 > r_4$ . The  $r_2$  is the best alternatives, which is the same with the results given by our proposed methods.

In a comparison between our proposed approaches and Tang *et al.*'s method [38], we observe:

- For HFLTSs with the different numbers of linguistic terms, Tang *et al.* [38] used the  $\beta$ -normalization [45] to normalize HFLTSs to guarantee they have the same numbers of linguistic terms. However, the LCME principle [52] is utilized to extend HFLFSs in this paper.
- In order to complement incomplete HFLPR, three procedures were proposed in [38] to complement the missing

$$\left( \begin{array}{c} \{(s_4, 0)\} \\ \{(s_5, 0), (s_5, 0), (s_4, 0.25), (s_4, 0.25), (s_5, -0.5), (s_5, -0.5)\} \\ \{(s_4, -0.25), (s_4, -0.25), (s_4, -0.25), (s_3, 0.25), (s_3, 0.25), (s_3, 0.25)\} \\ \{(s_4, -0.5), (s_4, -0.5), (s_3, 0.25), (s_3, -0.25), (s_3, -0.5), (s_3, -0.5)\} \\ \{(s_4, -0.5), (s_4, -0.5), (s_3, -0.25), (s_2, 0.25), (s_2, -0.25), (s_2, -0.25)\} \\ \{(s_3, 0), (s_3, 0), (s_3, 0.25), (s_3, 0.25), (s_4, -0.5), (s_4, -0.5)\} \\ \{(s_4, 0)\} \\ \{(s_3, 0.25), (s_3, 0.25), (s_3, 0.25), (s_3, -0.5), (s_3, -0.5), (s_3, -0.5)\} \\ \{(s_3, 0), (s_3, 0), (s_3, 0), (s_2, 0.25), (s_2, 0.25), (s_2, 0.25)\} \\ \{(s_3, -0.5), (s_3, -0.5), (s_3, -0.5), (s_1, 0.25), (s_1, 0.25), (s_1, 0.25)\} \\ \{(s_4, 0.25), (s_4, 0.25), (s_4, 0.25), (s_5, -0.25), (s_5, -0.25), (s_5, -0.25)\} \\ \{(s_5, -0.25), (s_5, -0.25), (s_5, -0.25), (s_6, -0.5), (s_6, -0.5), (s_6, -0.5)\} \\ \{(s_4, 0)\} \\ \{(s_4, -0.5), (s_4, -0.5), (s_4, -0.5), (s_4, -0.5), (s_4, -0.5), (s_4, -0.5)\} \\ \{(s_3, 0), (s_3, 0), (s_3, -0.25), (s_3, -0.25), (s_3, -0.5), (s_3, -0.5)\} \\ \{(s_5, -0.5), (s_5, -0.5), (s_5, -0.25), (s_5, 0.25), (s_5, 0.25), (s_6, -0.5)\} \\ \{(s_5, 0), (s_5, 0), (s_5, 0), (s_6, -0.25), (s_6, -0.25), (s_6, -0.25)\} \\ \{(s_5, -0.5), (s_5, -0.5), (s_5, -0.5), (s_5, -0.5), (s_5, -0.5), (s_5, -0.5)\} \\ \{(s_4, 0)\} \\ \{(s_4, -0.25), (s_4, -0.25), (s_4, -0.5), (s_3, 0.25), (s_3, 0), (s_3, 0)\} \\ \{(s_5, -0.5), (s_5, -0.5), (s_5, 0.25), (s_6, -0.25), (s_6, 0.25), (s_6, 0.25)\} \\ \{(s_6, -0.5), (s_6, -0.5), (s_6, -0.25), (s_7, -0.5), (s_7, -0.25), (s_7, -0.25)\} \\ \{(s_5, 0), (s_5, 0), (s_5, 0.25), (s_5, 0.25), (s_6, -0.5), (s_6, -0.5)\} \\ \{(s_4, 0.25), (s_4, 0.25), (s_5, -0.5), (s_5, -0.25), (s_5, 0), (s_5, 0)\} \\ \{(s_4, 0)\} \end{array} \right)$$

elements of incomplete HFLPR. However, the complete HFLPR derived from incomplete HFLPR by the three procedures may contain some virtual linguistic terms, which are utilized as DMs' preference information. Nevertheless, they may cause the decision making problem being difficult to understand by DMs. In this paper, an integer linear programming model is developed to estimate the missing elements based on the additive consistency of complete HFLPR. The optimization model not only complements missing information, but also ensures that the complemented information belongs to the initial evaluation linguistic term set. That is, the complete information is not virtual linguistic term.

- In [38], they ranked the alternatives and selected the best one based on the score values of alternatives. In this paper, a mixed 0-1 programming model is proposed for calculating complete HFLPRs' priority vectors, which are utilized to rank the alternatives.

### 3) SENSITIVITY ANALYSIS

Based on the procedure of the proposed method, the final decision result depends on DMs' weighting vector  $v$ . In what follows, by randomly generating ten sets of DMs' weighting vector, we explore how the DMs' weighting vector affects the final ranking. The related results are shown in Table 1. As shown in Table 1, it is very clear to see that choosing different DMs' weights can obtain same ranking orders of the

five alternatives, and the best alternative is almost always  $r_2$ . The simulation results show the good performance for our proposed method in robustness.

### B. A CASE OF AN INVESTMENT APPLICATION

The case study taken from [65]. Suppose that an investment company want to select a best project from four projects  $A_i (i = 1, 2, 3, 4)$  to invest with some idle funds. The company invites four experts  $e_k (k = 1, 2, 3, 4)$  from different departments.

#### 1) PROCEDURE OF INVESTMENT APPLICATION PROBLEM BASED ON OUR PROPOSED METHOD

*Step 1:* By using a linguistic term set  $S_{case} = \{s_0 : \text{very poor}, s_1 : \text{poor}, s_2 : \text{slightly poor}, s_3 : \text{fair}, s_4 : \text{slightly good}, s_5 : \text{good}, s_6 : \text{very good}\}$ , four experts give their preference information with incomplete HFLPRs listed as follows:

$$H_1 = \begin{pmatrix} \{s_3\} & \{s_4\} & \{s_4, s_5\} & x \\ \{s_2\} & \{s_3\} & x & \{s_5, s_6\} \\ \{s_2, s_1\} & x & \{s_3\} & \{s_1\} \\ x & \{s_1, s_0\} & \{s_5\} & \{s_3\} \end{pmatrix},$$

$$H_2 = \begin{pmatrix} \{s_3\} & x & \{s_3\} & x \\ x & \{s_3\} & \{s_5\} & \{s_2\} \\ \{s_3\} & \{s_1\} & \{s_3\} & \{s_1, s_2\} \\ x & \{s_4\} & \{s_5, s_4\} & \{s_3\} \end{pmatrix},$$

TABLE 1. Ranking order of alternatives for different DMs' weights.

The set of weights	$v_1$	$v_2$	$v_3$	$v_4$	$v_5$	Ranking order
1	0.2389	0.2408	0.0393	0.2422	0.2388	$r_2 \succ r_1 \succ r_3 \succ r_5 \succ r_4$
2	0.2406	0.2914	0.1992	0.0108	0.2579	$r_2 \succ r_1 \succ r_3 \succ r_5 \succ r_4$
3	0.2664	0.1936	0.2161	0.2120	0.1119	$r_2 \succ r_1 \succ r_3 \succ r_5 \succ r_4$
4	0.0233	0.0491	0.4162	0.3512	0.1603	$r_2 \succ r_1 \succ r_3 \succ r_5 \succ r_4$
5	0.3697	0.0134	0.1707	0.1484	0.2978	$r_2 \succ r_1 \succ r_3 \succ r_5 \succ r_4$
6	0.2307	0.2454	0.0898	0.2211	0.2130	$r_2 \succ r_1 \succ r_3 \succ r_5 \succ r_4$
7	0.2521	0.0964	0.3236	0.1099	0.2180	$r_2 \succ r_1 \succ r_3 \succ r_5 \succ r_4$
8	0.2161	0.2754	0.2965	0.1691	0.0428	$r_2 \succ r_1 \succ r_3 \succ r_5 \succ r_4$
9	0.0343	0.0979	0.1922	0.3365	0.3391	$r_2 \succ r_1 \succ r_3 \succ r_5 \succ r_4$
10	0.2401	0.2669	0.0374	0.2692	0.1864	$r_2 \succ r_1 \succ r_3 \succ r_5 \succ r_4$

$$H_3 = \begin{pmatrix} \{s_3\} & \{s_2\} & x & \{s_3, s_4, s_5\} \\ \{s_4\} & \{s_3\} & x & \{s_2\} \\ x & x & \{s_3\} & \{s_1\} \\ \{s_3, s_2, s_1\} & \{s_4\} & \{s_5\} & \{s_3\} \end{pmatrix},$$

$$H_4 = \begin{pmatrix} \{s_3\} & x & \{s_5\} & \{s_3, s_4\} \\ x & \{s_3\} & \{s_2\} & x \\ \{s_1\} & \{s_4\} & \{s_3\} & \{s_4, s_5\} \\ \{s_3, s_2\} & x & \{s_2, s_1\} & \{s_3\} \end{pmatrix}.$$

Step 2: According to the LCME principle, the normalized incomplete HFLPRs  $\tilde{H}_k (k = 1, 2, 3, 4)$  are as follows:

$$\tilde{H}_1 = \begin{pmatrix} \{s_3\} & \{s_4, s_4\} & \{s_4, s_5\} & x \\ \{s_2, s_2\} & \{s_3\} & x & \{s_5, s_6\} \\ \{s_2, s_1\} & x & \{s_3\} & \{s_1, s_1\} \\ x & \{s_1, s_0\} & \{s_5, s_5\} & \{s_3\} \end{pmatrix},$$

$$\tilde{H}_2 = \begin{pmatrix} \{s_3\} & x & \{s_3, s_3\} & x \\ x & \{s_3\} & \{s_5, s_5\} & \{s_2, s_2\} \\ \{s_3, s_3\} & \{s_1, s_1\} & \{s_3\} & \{s_1, s_2\} \\ x & \{s_4, s_4\} & \{s_5, s_4\} & \{s_3\} \end{pmatrix},$$

$$\tilde{H}_3 = \begin{pmatrix} \{s_3\} & \{s_2, s_2, s_2, s_2, s_2, s_2\} \\ \{s_4, s_4, s_4, s_4, s_4, s_4\} & \{s_3\} \\ x & x \\ \{s_3, s_3, s_2, s_2, s_1, s_1\} & \{s_4, s_4, s_4, s_4, s_4, s_4\} \\ x & \{s_3, s_3, s_4, s_4, s_5, s_5\} \\ x & \{s_2, s_2, s_2, s_2, s_2, s_2\} \\ \{s_3\} & \{s_1, s_1, s_1, s_1, s_1, s_1\} \\ \{s_5, s_5, s_5, s_5, s_5, s_5\} & \{s_3\} \end{pmatrix},$$

$$\tilde{H}_4 = \begin{pmatrix} \{s_3\} & x & \{s_5, s_5\} & \{s_3, s_4\} \\ x & \{s_3\} & \{s_2, s_2\} & x \\ \{s_1, s_1\} & \{s_4, s_4\} & \{s_3\} & \{s_4, s_5\} \\ \{s_3, s_2\} & x & \{s_2, s_1\} & \{s_3\} \end{pmatrix}.$$

Step 3: By (ILP2) model, we have the complete HFLPRs  $\tilde{H}_k (k = 1, 2, 3, 4)$  as follows:

$$\tilde{H}_1 = \begin{pmatrix} \{s_3\} & \{s_4, s_4\} & \{s_4, s_5\} & \{s_6, s_6\} \\ \{s_2, s_2\} & \{s_3\} & \{s_6, s_6\} & \{s_5, s_6\} \\ \{s_2, s_1\} & \{s_0, s_0\} & \{s_3\} & \{s_1, s_1\} \\ \{s_0, s_0\} & \{s_1, s_0\} & \{s_5, s_5\} & \{s_3\} \end{pmatrix},$$

$$\tilde{H}_2 = \begin{pmatrix} \{s_3\} & \{s_1, s_1\} & \{s_3, s_3\} & \{s_1, s_2\} \\ \{s_5, s_5\} & \{s_3\} & \{s_5, s_5\} & \{s_2, s_2\} \\ \{s_3, s_3\} & \{s_1, s_1\} & \{s_3\} & \{s_1, s_2\} \\ \{s_5, s_4\} & \{s_4, s_4\} & \{s_5, s_4\} & \{s_3\} \end{pmatrix},$$

$$\tilde{H}_3 = \begin{pmatrix} \{s_3\} & \{s_2, s_2, s_2, s_2, s_2, s_2\} \\ \{s_4, s_4, s_4, s_4, s_4, s_4\} & \{s_3\} \\ \{s_1, s_1, s_0, s_0, s_0, s_0\} & \{s_2, s_2, s_2, s_2, s_2, s_2\} \\ \{s_3, s_3, s_2, s_2, s_1, s_1\} & \{s_4, s_4, s_4, s_4, s_4, s_4\} \\ \{s_5, s_5, s_6, s_6, s_6, s_6\} & \{s_3, s_3, s_4, s_4, s_5, s_5\} \\ \{s_4, s_4, s_4, s_4, s_4, s_4\} & \{s_2, s_2, s_2, s_2, s_2, s_2\} \\ \{s_3\} & \{s_1, s_1, s_1, s_1, s_1, s_1\} \\ \{s_5, s_5, s_5, s_5, s_5, s_5\} & \{s_3\} \end{pmatrix},$$

$$\tilde{H}_4 = \begin{pmatrix} \{s_3\} & \{s_6, s_6\} & \{s_5, s_5\} & \{s_3, s_4\} \\ \{s_0, s_0\} & \{s_3\} & \{s_2, s_2\} & \{s_0, s_1\} \\ \{s_1, s_1\} & \{s_4, s_4\} & \{s_3\} & \{s_4, s_5\} \\ \{s_3, s_2\} & \{s_6, s_5\} & \{s_2, s_1\} & \{s_3\} \end{pmatrix}.$$

Step 4: According to Eq. (11), the additive consistency index  $CI(\tilde{H}_k) (k = 1, 2, 3, 4)$  are as follows:

$$CI(\tilde{H}_1) = 0.1111, CI(\tilde{H}_2) = 0.0417,$$

$$CI(\tilde{H}_3) = 0.0833, CI(\tilde{H}_4) = 0.0833.$$

It is easy for us to know that all complete HFLPRs are acceptable additive consistency. Hence, Step 5 is carried out.

Step 5: Let DMs weighting vector  $v = (0.4, 0.3, 0.2, 0.1)^T$  [65]. By using Eq. (12), we have synthetic HFLPR  $\tilde{H}^s$  is, as shown at the top of the next page.

Step 6: By (MPM), one can obtain the priority vector  $w^*$  of  $\tilde{H}^s$  as:

$$w^* = (w_1^*, w_2^*, w_3^*, w_4^*) = (0.3880, 0.3893, 0, 0.2227).$$

Step 7: Ranking priority weights in descending order, we have

$$w_2^* > w_1^* > w_4^* > w_3^*.$$

Step 8: Based on the ranking result in Step 7, the four projects are ranked as

$$A_2 \succ A_1 \succ A_4 \succ A_3.$$

The best project is  $A_2$ .

## 2) COMPARATIVE ANALYSIS AND DISCUSSION

In this subsection, some quantitative comparisons between our proposed method and other existing methods [38], [58], [65] are provided.

Different methods [38], [58], [65] for GDM with incomplete HFLPR are used to solve the investment problem. The ranking results of the four projects are summarized in Table 2.

**TABLE 2. The ranking results of the four projects with different methods.**

References	The ranking methods	The ranking results
This paper	Priority vector	$A_2 \succ A_1 \succ A_4 \succ A_3$
Ref. [38]	Score values	$A_1 \succ A_2 \succ A_4 \succ A_3$
Ref. [58]	Score values	$A_1 \succ A_4 \succ A_2 \succ A_3$
Ref. [65]	Preference degree	$A_1 \succ A_2 \succ A_4 \succ A_3$

Based on Table 2, we find that the ranking results obtained by our proposed method are slightly different from those obtained by other methods in [38], [58], [65]. The differences between our proposed method and other methods [38], [58], [65] are summarized as follows.

- In [38], the method for complementing missing information may provide some virtual linguistic terms as the complete information. In [58], the missing values can be completed by using the elements of the worst linguistic preference relation and the best linguistic preference. To deal with virtual linguistic terms, the absolute deviation is constructed. In [65], the authors did not provide the completing method for missing values.
- The form of synthetic HFLPR (in [38], [58], [65] called collective HFLPR) is different. In [38], the collective HFLPR contains some virtual linguistic terms. In [58], [65], the collective preference relation is 2-tuple fuzzy linguistic preference relation. In this paper, the preference information in synthetic HFLPR is hesitant 2-tuple linguistic.
- In [38], [58] and this paper, the consistency level of complete HFLPR is considered. But this situation is ignored in [65].

Next, we discuss the differences in these methods for complementing missing information in detail. In [38], the situation of the missing information in incomplete HFLPR was discussed in detail. Then, three procedures to estimate the missing information were proposed. An algorithm for GDM

with incomplete HFLPRs was developed. In [58], the authors constructed optimization models to estimate the missing information of incomplete HFLPR by using worst and best additive consistency of HFLPR defined by [44]. Then, for complete HFLPR, a consistency improving algorithm was proposed. The main method of dealing with the incomplete HFLPR in [65] is to use a fuzzy linear programming to transform it into 2-tuple fuzzy linguistic preference relation.

Different methods for completing missing information are applied to the four incomplete HFLPRs, respectively. The corresponding results are listed in Table 3. As can be seen from fourth column of Table 3, some complete information provided by [38] are virtual linguistic terms. This could lead to the decision making problem to be difficult to understand for the experts. For [58], as shown in Table 2 fifth column, a common feature of this information, including  $\{s_0, \dots, s_3\}$ ,  $\{s_0, \dots, s_4\}$ ,  $\{s_2, \dots, s_6\}$ ,  $\{s_0, \dots, s_6\}$  and  $\{s_0, \dots, s_3\}$ , is that they contain a linguistic term  $s_3$ , which represents fair. For example, HFLTS  $\{s_0, \dots, s_3\}$  indicates that the expert  $e_1$  believes that the importance of  $A_1$  relative to  $A_2$  is very poor, poor, slightly poor and fair. In practical decision making process, this preference information is not up to human cognition. In [65], the complete information is not discussed. However, our proposed method can well deal with the missing information since the complemented information is not virtual linguistic terms and it is in accordance with human cognitive ideas.

Different methods for incomplete HFLPR have their own characteristics and applicable decision making problems. In summary, this GDM problem indicates that the approaches proposed in this paper is fundamentally different from previously developed methods because the (ILP) model and (MPM) can well address incomplete HFLPRs' missing values and priority vector of complete HFLPR. Therefore, the approaches have the potential to be widely applied in

$$\left( \begin{array}{c} \{(s_3, 0)\} \\ \{(s_3, 0.1), (s_3, 0.1), (s_3, 0.1), (s_3, 0.1), (s_3, 0.1), (s_3, 0.1)\} \\ \{(s_2, 0), (s_2, 0), (s_2, -0.2), (s_1, 0.4), (s_1, 0.4), (s_1, 0.4)\} \\ \{(s_2, 0.4), (s_2, 0.4), (s_2, 0.2), (s_2, -0.2), (s_2, -0.4), (s_2, -0.4)\} \\ \{(s_3, -0.1), (s_3, -0.1), (s_3, -0.1), (s_3, -0.1), (s_3, -0.1), (s_3, -0.1)\} \\ \{(s_3, 0)\} \\ \{(s_1, 0.1), (s_1, 0.1), (s_1, 0.1), (s_1, 0.1), (s_1, 0.1), (s_1, 0.1)\} \\ \{(s_3, 0), (s_3, 0), (s_3, 0), (s_2, 0.5), (s_2, 0.5), (s_2, 0.5)\} \\ \{(s_4, 0), (s_4, 0), (s_4, 0.2), (s_5, -0.4), (s_5, -0.4), (s_5, -0.4)\} \\ \{(s_5, -0.1), (s_5, -0.1), (s_5, -0.1), (s_5, -0.1), (s_5, -0.1), (s_5, -0.1)\} \\ \{(s_3, 0)\} \\ \{(s_5, -0.3), (s_5, -0.3), (s_5, -0.3), (s_4, 0.3), (s_4, 0.3), (s_4, 0.3)\} \\ \{(s_4, -0.4), (s_4, -0.4), (s_4, -0.2), (s_4, 0.2), (s_4, 0.4), (s_4, 0.4)\} \\ \{(s_3, 0), (s_3, 0), (s_3, 0), (s_4, -0.5), (s_4, -0.5), (s_4, -0.5)\} \\ \{(s_1, 0.3), (s_1, 0.3), (s_1, 0.3), (s_2, -0.3), (s_2, -0.3), (s_2, -0.3)\} \\ \{(s_3, 0)\} \end{array} \right)$$

TABLE 3. The corresponding results of different methods.

Incomplete HFLPR	Missing information	Our method	Complemented Ref. [38]	information Ref. [58]	Ref. [65]
$H_1$	$h_{14}^1$	$\{s_6, s_6\}$	$\{s_{1.8}, s_{2.4}\}$	$\{s_0, \dots, s_3\}$	Not given
$H_2$	$h_{23}^1$	$\{s_6, s_6\}$	$\{s_0, s_{0.6}\}$	$\{s_0, \dots, s_4\}$	Not given
	$h_{12}^2$	$\{s_1, s_1\}$	$\{s_{-1.2}, s_{-1.2}\}$	$\{s_2, \dots, s_6\}$	Not given
$H_3$	$h_{14}^2$	$\{s_1, s_2\}$	$\{s_{-2.2}, s_{-2.2}\}$	$\{s_0, s_1\}$	Not given
	$h_{33}^3$	$\{s_5, s_5, s_6, s_6, s_6, s_6\}$	$\{s_{1.2}, s_{1.8}, s_{2.4}\}$	$\{s_0, \dots, s_5\}$	Not given
$H_4$	$h_{23}^3$	$\{s_4, s_4, s_4, s_4, s_4, s_4\}$	$\{s_{1.8}, s_{2.4}, s_3\}$	$\{s_4, s_5, s_6\}$	Not given
	$h_{12}^4$	$\{s_6, s_6\}$	$\{s_3, s_3\}$	$\{s_0, \dots, s_6\}$	Not given
	$h_{24}^4$	$\{s_0, s_1\}$	$\{s_{-3}, s_{-2}\}$	$\{s_0, \dots, s_3\}$	Not given

GDM with incomplete HFLPRs. Based on the above analyses, the advantages of the proposed method are as follows:

- The proposed method can well deal with the missing information since the complemented information is not virtual linguistic terms and it is in accordance with human cognitive ideas.
- Since the collective HFLPR is still hesitant and qualitative, the proposed method can retain the form of the preference information as much as possible.
- For complete HFLPR, a mixed 0-1 programming model is developed to derive priority vector that is used to rank alternatives.

VI. CONCLUSION

Due to the uncertainty and complexity in real decision making problems, DMs may express their qualitative and hesitant preference information using some incomplete HFLPRs in the process of GDM. In this paper, two optimization models are developed. One is to complement the missing elements of incomplete HFLPRs, the other is to derive priority vector from the complete HFLPRs. The contributions of the proposed methods are summarized as follows:

- (1) Based on the property of additive consistent HFLPR, an integer linear programming model has been proposed to complement the missing elements of incomplete HFLPR. The optimization model not only complements missing elements, but also ensures that the complemented information is not virtual linguistic terms.
- (2) Then, a mixed 0-1 programming model for deriving the priority vector from complete HFLPR has been proposed.
- (3) After that, an approach for addressing the GDM problem with incomplete HFLPRs has been presented by integrating the integer linear programming model and the mixed 0-1 programming model.
- (4) Two case studies and comparative analysis have been provided to verify the feasibility and advantages of the proposed approach.

In the future, these proposed models can be used to deal with other kinds of IPRs with linguistic information [54], [59]. On the other hand, we will focus on investigating some other preference relations with kinds of new information forms, such as interval-valued Pythagorean fuzzy information [60] and interval-valued Bipolar fuzzy information [61].

APPENDIX

The following abbreviations are used in this manuscript:

Abbreviations	
GDM	Group decision making
HFLPR	Hesitant fuzzy linguistic preference relation
DM	Decision maker
IPR	Incomplete preference relation
IMPR	Interval multiplicative preference relation
HFPR	Hesitant fuzzy preference relation
HFLTST	Hesitant fuzzy linguistic term set
LPR	Linguistic preference relation
LCME	Least common multiple expansion
N-HFLPR	Normalized hesitant fuzzy linguistic preference relation
NP	Nonlinear programming
NIP	Nonlinear integer programming
ILP	Integer linear programming
MPM	Mixed 0-1 programming model

REFERENCES

- [1] T. L. Saaty, *The Analytic Hierarchy Process*. New York, NY, USA: McGraw-Hill, 1980.
- [2] S. A. Orlovsky, "Decision-making with a fuzzy preference relation," *Fuzzy Sets Syst.*, vol. 1, no. 3, pp. 155–167, 1978.
- [3] T. L. Saaty and L. G. Vargas, "Uncertainty and rank order in the analytic hierarchy process," *Eur. J. Oper. Res.*, vol. 32, pp. 107–117, Oct. 1987.
- [4] Z. Xu, "On compatibility of interval fuzzy preference relations," *Fuzzy Optim. Decis. Making*, vol. 3, pp. 217–225, Sep. 2004.
- [5] P. J. M. van Laarhoven and W. Pedrycz, "A fuzzy extension of Saaty's priority theory," *Fuzzy Sets Syst.*, vol. 11, nos. 1–3, pp. 229–241, 1983.
- [6] P. Wu, S. Liu, L. Zhou, and H. Chen, "A fuzzy group decision making model with trapezoidal fuzzy preference relations based on compatibility measure and COWGA operator," *Appl. Intell.*, vol. 48, no. 1, pp. 46–67, 2018.
- [7] P. Wu, Q. Wu, L. Zhou, H. Chen, and H. Zhou, "A consensus model for group decision making under trapezoidal fuzzy numbers environment," *Neural Comput. Appl.*, vol. 31, no. 2, pp. 377–394, 2019.
- [8] Z. Xu, "Intuitionistic preference relations and their application in group decision making," *Inf. Sci.*, vol. 177, no. 11, pp. 2363–2379, 2007.
- [9] B. Zhu, Z. Xu, and J. Xu, "Deriving a ranking from hesitant fuzzy preference relations under group decision making," *IEEE Trans. Cybern.*, vol. 44, no. 8, pp. 1328–1337, Aug. 2014.
- [10] Z. Xu, "A practical procedure for group decision making under incomplete multiplicative linguistic preference relations," *Group Decis. Negotiation*, vol. 15, pp. 581–591, Nov. 2006.
- [11] F. Liu, W.-G. Zhang, and Z.-X. Wang, "A goal programming model for incomplete interval multiplicative preference relations and its application in group decision-making," *Eur. J. Oper. Res.*, vol. 218, pp. 747–754, May 2012.
- [12] M. Zhao, X.-Y. Ma, and D.-W. Wei, "A method considering and adjusting individual consistency and group consensus for group decision making with incomplete linguistic preference relations," *Appl. Soft Comput.*, vol. 54, pp. 322–346, May 2017.
- [13] F. Meng and X. Chen, "A new method for group decision making with incomplete fuzzy preference relations," *Knowl.-Based Syst.*, vol. 73, no. 1, pp. 111–123, 2015.
- [14] Z.-J. Wang and X.-Y. Zhang, "A two-stage acceptable hesitancy based goal programming framework to evaluating missing values of incomplete intuitionistic reciprocal preference relations," *Comput. Ind. Eng.*, vol. 105, pp. 190–200, Mar. 2017.



- [15] F. Meng and X. Chen, "An approach to incomplete multiplicative preference relations and its application in group decision making," *Inf. Sci.*, vol. 309, pp. 119–137, Jul. 2015.
- [16] Y. Xu, K. W. Li, and H. Wang, "Incomplete interval fuzzy preference relations and their applications," *Comput. Ind. Eng.*, vol. 67, pp. 93–103, Jan. 2014.
- [17] H. Wang and Z. Xu, "Interactive algorithms for improving incomplete linguistic preference relations based on consistency measures," *Appl. Soft Comput.*, vol. 42, pp. 66–79, May 2016.
- [18] Z. S. Xu, "Goal programming models for obtaining the priority vector of incomplete fuzzy preference relation," *Int. J. Approx. Reasoning*, vol. 36, pp. 261–270, Jul. 2004.
- [19] Z.-W. Gong, "Least-square method to priority of the fuzzy preference relations with incomplete information," *Int. J. Approx. Reasoning*, vol. 47, pp. 258–264, Feb. 2008.
- [20] Y. Xu, L. Chen, K. W. Li, and H. Wang, "A chi-square method for priority derivation in group decision making with incomplete reciprocal preference relations," *Inf. Sci.*, vol. 306, pp. 166–179, Jun. 2015.
- [21] Y. Xu, L. Chen, and H. Wang, "A least deviation method for priority derivation in group decision making with incomplete reciprocal preference relations," *Int. J. Approx. Reasoning*, vol. 66, pp. 91–102, Nov. 2015.
- [22] Z. Zhang and C. Guo, "An approach to group decision making with heterogeneous incomplete uncertain preference relations," *Comput. Ind. Eng.*, vol. 71, pp. 27–36, May 2014.
- [23] Z. Zhang, "Deriving the priority weights from incomplete hesitant fuzzy preference relations based on multiplicative consistency," *Appl. Soft Comput.*, vol. 46, pp. 37–59, Sep. 2016.
- [24] Y. Xu, L. Chen, R. M. Rodríguez, F. Herrera, and H. Wang, "Deriving the priority weights from incomplete hesitant fuzzy preference relations in group decision making," *Knowl.-Based Syst.*, vol. 99, pp. 71–78, May 2016.
- [25] Y. Xu and H. Wang, "Eigenvector method, consistency test and inconsistency repairing for an incomplete fuzzy preference relation," *Appl. Math. Model.*, vol. 37, pp. 5171–5183, Apr. 2013.
- [26] Z. Zhang, X. Y. Kou, W. Y. Yu, and C. H. Guo, "On priority weights and consistency for incomplete hesitant fuzzy preference relations," *Knowl.-Based Syst.*, vol. 143, pp. 115–126, Mar. 2018.
- [27] R. Ureña, F. Chiclana, J. A. Morente-Molinera, and E. Herrera-Viedma, "Managing incomplete preference relations in decision making: A review and future trends," *Inf. Sci.*, vol. 302, pp. 14–32, May 2015.
- [28] R. M. Rodríguez, L. Martínez, and F. Herrera, "Hesitant fuzzy linguistic term sets for decision making," *IEEE Trans. Fuzzy Syst.*, vol. 20, no. 1, pp. 109–119, Feb. 2012.
- [29] H. Liao, Z. Xu, and X. Zeng, "Distance and similarity measures for hesitant fuzzy linguistic term sets and their application in multi-criteria decision making," *Inf. Sci.*, vol. 271, pp. 125–142, Jul. 2014.
- [30] H. Liao and Z. Xu, "Approaches to manage hesitant fuzzy linguistic information based on the cosine distance and similarity measures for HFLTSs and their application in qualitative decision making," *Expert Syst. Appl.*, vol. 42, no. 12, pp. 5328–5336, Jul. 2015.
- [31] H. Liao, Z. Xu, X.-J. Zeng, and J. M. Merigó, "Qualitative decision making with correlation coefficients of hesitant fuzzy linguistic term sets," *Knowl.-Based Syst.*, vol. 76, pp. 127–138, Mar. 2015.
- [32] H. Liao, Z. Xu, and X. J. Zeng, "Hesitant fuzzy linguistic VIKOR method and its application in qualitative multiple criteria decision making," *IEEE Trans. Fuzzy Syst.*, vol. 23, no. 5, pp. 1343–1355, Oct. 2015.
- [33] H. Liao, L. Yang, and Z. Xu, "Two new approaches based on ELECTRE II to solve the multiple criteria decision making problems with hesitant fuzzy linguistic term sets," *Appl. Soft Comput.*, vol. 63, pp. 223–234, Feb. 2018.
- [34] J. Wang, J. Q. Wang, and H. Y. Zhang, "A likelihood-based TODIM approach based on multi-hesitant fuzzy linguistic information for evaluation in logistics outsourcing," *Comput. Ind. Eng.*, vol. 99, pp. 287–299, Sep. 2016.
- [35] J.-Q. Wang, J. Wang, Q.-H. Chen, H.-Y. Zhang, and X.-H. Chen, "An out-ranking approach for multi-criteria decision-making with hesitant fuzzy linguistic term sets," *Inf. Sci.*, vol. 280, pp. 338–351, Oct. 2014.
- [36] J.-Y. Dong, Y. Chen, and S.-P. Wan, "A cosine similarity based QUALIFLEX approach with hesitant fuzzy linguistic term sets for financial performance evaluation," *Appl. Soft Comput.*, vol. 69, pp. 316–329, Aug. 2018.
- [37] H. Liao, G. Si, Z. Xu, and H. Fujita, "Hesitant fuzzy linguistic preference utility set and its application in selection of fire rescue plans," *Int. J. Environ. Res. Public Health*, vol. 15, no. 4, p. 664, 2018.
- [38] M. Tang, H. Liao, Z. Li, and Z. Xu, "Nature disaster risk evaluation with a group decision making method based on incomplete hesitant fuzzy linguistic preference relations," *Int. J. Environ. Res. Public Health*, vol. 15, no. 4, p. 751, 2018.
- [39] E. Herrera-Viedma, F. Chiclana, F. Herrera, and S. Alonso, "Group decision-making model with incomplete fuzzy preference relations based on additive consistency," *IEEE Trans. Syst. Man, Cybern. B, Cybern.*, vol. 37, no. 1, pp. 176–189, Feb. 2017.
- [40] L. Wang and Z. Gong, "Priority of a hesitant fuzzy linguistic preference relation with a normal distribution in meteorological disaster risk assessment," *Int. J. Environ. Res. Public Health*, vol. 14, no. 10, p. 1203, 2017.
- [41] X. Mi, X. Wu, M. Tang, H. Liao, A. Al-Barakati, A. H. Altalhi, and F. Herrera, "Hesitant fuzzy linguistic analytic hierarchical process with prioritization, consistency checking, and inconsistency repairing," *IEEE Access*, vol. 7, pp. 44135–44149, 2019.
- [42] K.-H. Chang, "A more general reliability allocation method using the hesitant fuzzy linguistic term set and minimal variance OWGA weights," *Appl. Soft Comput.*, vol. 56, pp. 589–596, Jul. 2017.
- [43] Z. Fu, X. Wu, H. Liao, and F. Herrera, "Underground mining method selection with the hesitant fuzzy linguistic gained and lost dominance score method," *IEEE Access*, vol. 6, pp. 66442–66458, 2018.
- [44] C.-C. Li, R. M. Rodríguez, F. Herrera, L. Martínez, and Y. Dong, "Consistency of hesitant fuzzy linguistic preference relations: An interval consistency index," *Inf. Sci.*, vol. 432, pp. 347–361, Mar. 2018.
- [45] B. Zhu and Z. Xu, "Consistency measures for hesitant fuzzy linguistic preference relations," *IEEE Trans. Fuzzy Syst.*, vol. 22, no. 1, pp. 35–45, Feb. 2014.
- [46] H. Liu, J. Cai, and L. Jiang, "On improving the additive consistency of the fuzzy preference relations based on comparative linguistic expressions," *Int. J. Intell. Syst.*, vol. 29, no. 6, pp. 544–559, 2014.
- [47] Z. Wu and J. Xu, "Managing consistency and consensus in group decision making with hesitant fuzzy linguistic preference relations," *Omega*, vol. 65, pp. 28–40, Dec. 2016.
- [48] Z. Zhang and C. Wu, "On the use of multiplicative consistency in hesitant fuzzy linguistic preference relations," *Knowl.-Based Syst.*, vol. 72, pp. 13–27, Dec. 2014.
- [49] Z. Xu, "Deviation measures of linguistic preference relations in group decision making," *Omega*, vol. 33, pp. 249–254, Jun. 2005.
- [50] Y. Dong, C.-C. Li, and F. Herrera, "An optimization-based approach to adjusting unbalanced linguistic preference relations to obtain a required consistency level," *Inf. Sci.*, vol. 292, no. 5, pp. 27–38, Jan. 2015.
- [51] F. Jin, Z. Ni, H. Chen, and Y. Li, "Approaches to decision making with linguistic preference relations based on additive consistency," *Appl. Soft Comput.*, vol. 49, pp. 71–80, Dec. 2016.
- [52] P. Wu, L. Zhou, H. Chen, and Z. Tao, "Additive consistency of hesitant fuzzy linguistic preference relation with a new expansion principle for hesitant fuzzy linguistic term sets," *IEEE Trans. Fuzzy Syst.*, vol. 27, no. 4, pp. 716–730, Apr. 2019.
- [53] G. Schryen and F. Wex, "Risk reduction in natural disaster management through information systems: A literature review and an IS design science research agenda," *Int. J. Inf. Syst. Crisis Response Manage.*, vol. 6, pp. 38–64, Jan. 2014.
- [54] Y. Xu, F. Ma, F. Tao, and H. Wang, "Some methods to deal with unacceptable incomplete 2-tuple fuzzy linguistic preference relations in group decision making," *Knowl.-Based Syst.*, vol. 56, pp. 179–190, Jan. 2014.
- [55] F. Herrera and L. Martínez, "A 2-tuple fuzzy linguistic representation model for computing with words," *IEEE Trans. Fuzzy Syst.*, vol. 8, no. 6, pp. 746–752, Dec. 2000.
- [56] R. M. Rodríguez and L. Martínez, "An analysis of symbolic linguistic computing models in decision making," *Int. J. Gen. Syst.*, vol. 42, no. 1, pp. 121–136, 2012.
- [57] C. Wei and H. Liao, "A multigranularity linguistic group decision-making method based on hesitant 2-tuple sets," *Int. J. Intell. Syst.*, vol. 31, no. 6, pp. 612–634, Jun. 2016.
- [58] H. Liu, Y. Ma, and L. Jiang, "Managing incomplete preferences and consistency improvement in hesitant fuzzy linguistic preference relations with applications in group decision making," *Inf. Fusion*, vol. 51, pp. 19–29, Nov. 2019.
- [59] Y. Xu, F. Ma, and F. Herrera, "Revisiting inconsistent judgments for incomplete fuzzy linguistic preference relations: Algorithms to identify and rectify ordinal inconsistencies," *Knowl.-Based Syst.*, vol. 163, pp. 305–319, Jan. 2019.

[60] G. Wei, H. Garg, H. Gao, and C. Wei, "Interval-valued pythagorean fuzzy Maclaurin symmetric mean operators in multiple attribute decision making," *IEEE Access*, vol. 6, pp. 67866–67884, 2018.

[61] G. Wei, C. Wei, and H. Gao, "Multiple attribute decision making with interval-valued bipolar fuzzy information and their application to emerging technology commercialization evaluation," *IEEE Access*, vol. 6, pp. 60930–60955, 2018.

[62] L. A. Zadeh, "The concept of a linguistic variable and its application to approximate reasoning—I," *Inf. Sci.*, vol. 8, no. 3, pp. 199–249, 1975.

[63] C. Wei, N. Zhao, and X. Tang, "Operators and comparisons of hesitant fuzzy linguistic term sets," *IEEE Trans. Fuzzy Syst.*, vol. 22, no. 3, pp. 575–585, Jun. 2014.

[64] Z. Wu and J. Xu, "Possibility distribution-based approach for MAGDM with hesitant fuzzy linguistic information," *IEEE Trans. Cybern.*, vol. 46, no. 3, pp. 694–705, Mar. 2016.

[65] Y. Song and J. Hu, "A group decision-making model based on incomplete comparative expressions with hesitant linguistic terms," *Appl. Soft Comput.*, vol. 59, pp. 174–181, Oct. 2017.

[66] P. Wu, L. Zhou, H. Chen, and Z. Tao, "Multi-stage optimization model for hesitant qualitative decision making with hesitant fuzzy linguistic preference relations," *Appl. Intell.*, pp. 1–19, Jul. 2019. doi: [10.1007/s10489-019-01502-8](https://doi.org/10.1007/s10489-019-01502-8).

[67] P. Wu, J. Zhu, L. Zhou, and H. Chen, "Automatic iterative algorithm with local revised strategies to improve the consistency of hesitant fuzzy linguistic preference relations," *Int. J. Fuzzy Syst.*, vol. 21, no. 7, pp. 2283–2298, 2019. doi: [10.1007/s40815-019-00715-w](https://doi.org/10.1007/s40815-019-00715-w).



**JOSÉ M. MERIGÓ** received the bachelor's degree in science and of social sciences in economics and the master's degree in European business administration and business law from Lund University, Sweden, and the master's and Ph.D. degrees in business administration from the University of Barcelona. He is currently a Professor with the School of Information, Systems, and Modeling, Faculty of Engineering and Information Technology, University of Technology Sydney, Australia.

Before joining UTS, he was a Full Professor with the Department of Management Control and Information Systems, University of Chile. Previously, he was a Senior Research Fellow with the Manchester Business School, University of Manchester, U.K., and an Assistant Professor with the Department of Business Administration, University of Barcelona, Spain. He has published more than 400 articles in journals, books, and conference proceedings. He is on the editorial board of several journals. He has also been a Guest Editor for several international journals, a member of the scientific committee of several conferences, and a Reviewer in a wide range of international journals. Recently, from 2015 to 2018, Clarivate Analytics (previously Thomson & Reuters) has distinguished him as a Highly Cited Researcher in computer science. He is currently interested in decision making, aggregation operators, computational intelligence, bibliometrics, and applications in business and economics.

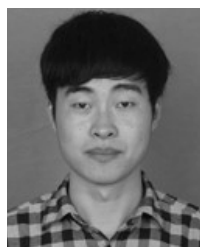

**PENG WU** is currently pursuing the Ph.D. degree with the School of Mathematical Sciences, Anhui University, Hefei, China. His profession is statistics. His current research interests include group decision making theory, forecasting, and information fusion. He has contributed over ten journal articles to professional journals, including the *IEEE TRANSACTIONS ON FUZZY SYSTEMS*, the *Neural Computing and Applications*, *Computers and Industrial Engineering*, the *Applied Intelligence*,

the *International Journal of Fuzzy Systems*, and the *Journal of Intelligent and Fuzzy Systems and Physica A*. He is also a Paper Reviewer of many international journals, such as the *IEEE TRANSACTIONS ON FUZZY SYSTEMS*, *IEEE ACCESS*, and the *Journal of Experimental and Theoretical Artificial Intelligence*.

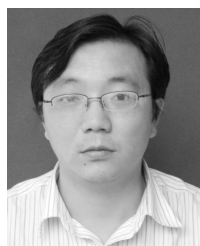

**HONGYAN LI** is currently pursuing the Ph.D. degree in statistics with the School of Mathematics, Anhui University. His main research interests include statistical decision analysis and group decision making.



**LIGANG ZHOU** received the Ph.D. degree in operational research from Anhui University, Hefei, China, in 2013, where he is currently a Professor with the School of Mathematical Sciences. He has contributed over 100 journal articles to professional journals, such as the *IEEE TRANSACTIONS ON FUZZY SYSTEMS*, *FUZZY SETS AND SYSTEMS*, the *Information Sciences*, the *Applied Mathematical Modeling*, the *Group Decision and Negotiation*, and so on. He is also a Paper

Reviewer of many international journals. His current research interests include information fusion, group decision making, aggregation operators, and combined forecasting. For further information, see his webpage: <http://math.ahu.edu.cn/web/user.asp?id=82>.

...