



Water use patterns of forage cultivars in the North China Plain

G. Pan^{a,c,d}, Zh. Ouyang^{a,*}, Q. Luo^b, Q. Yu^{a,b}, J. Wang^a

^aYucheng Integrated Experimental Station, Key Laboratory of Ecosystem Network Observation and Modelling, Institute of Geographic Sciences and Natural Resources Research, Chinese Academy of Sciences (CAS), 100101 Beijing, China.

^bPlant Functional Biology and Climate Change Cluster, University of Technology, Sydney, PO Box 123 Broadway, NSW 2007, Australia.

^cState Key Laboratory of Water Resources and Hydropower Engineering Science, Wuhan University, Wuhan, 430072, Hubei, China.

^dGraduate University of Chinese Academy of Sciences, Beijing 100049, China.

*Corresponding author. E-mail: ouyz@igsnr.ac.cn

Received 30 October 2010; Accepted after revision 27 November 2010; Published online 15 March 2011

Abstract

Water shortage is the primary limiting factor for crop production and long-term agricultural sustainability of the North China Plain. Forage cultivation emerged recently in this region. A five-year field experiment studies were conducted at Yucheng Integrated Experiment Station to quantify the water requirement and water use efficiency of seven forage varieties under climate variability, that is five annuals, i.e., ryegrass (*Secale cereale* L.), triticale (\times *Triticosecale* Wittmack), sorghum hybrid sudangrass (*Sorghum biolor* \times *Sorghum Sudanense* c.v.), ensilage corn (*Zea mays* L.), prince's feather (*Amaranthus paniculatus* L.) and two perennials alfalfa (*Medicago sativa* L.) and cup plant (*Silphium perfoliatum* L.). Average ET for five annual varieties ranged from 333 to 371 mm, significantly lower than that of the perennial varieties. ET of alfalfa is 789 mm, which is higher than that of cup plant. Ryegrass and triticale need 1.5 to 2.0 mm water per day, while others 2.9-4.4 mm. Ensilage corn and Sorghum hybrid sudangrass performed better as their irrigation demand is smaller in the dry seasons than others. Ryegrass needs 281 mm irrigation requirement, which is higher than triticale in dry years. Prince's feather is sensitive to climate change and it can be selected when rainfall is greater than 592.9 mm in the growing season. Mean WUE for prince's feather is 20 Kg ha⁻¹ mm⁻¹, for ensilage corn is 41 Kg ha⁻¹ mm⁻¹ and others is close to 26 Kg ha⁻¹ mm⁻¹. Our experiments indicate that excessive rain will reduce the production of alfalfae. The results of this experiment have implications for researchers and policy makers with water management strategy of forage cultivars and it also very useful in addressing climate change impact and adaptation issues.

Keywords: Forage cultivars; Evapotranspiration; Irrigation demand; Water use efficiency; Climatic patterns.

Introduction

The North China Plain (NCP) is the most important grain production area as well as a major area for animal husbandry in China. The arable land in this plain covers 13.8% of national total and produced grain (20.2%), meat (37.0%), beef (49.1%), mutton (41.3%), poultry (43.7%), milk (31.1%) and eggs (58.6%) for the nation.

Continuous winter wheat-summer maize cropping system dominates this production area. Annual evapotranspiration (ET) of this continual cropping system may reach 800-900 mm in this region (Liu et al., 2002), higher than the mean annual precipitation. Water shortage is the primary limiting factor of crop production in this area (Fang et al., 2010). Irrigation is required by diversion from Yellow River or from groundwater, but there is a great challenge to the agricultural and environment sustainability with drying up of rivers and lowering of groundwater table (Fang et al., 2010). Water management at farm level consists of the determination of water requirement and irrigation schedule, which are crucial steps to solve water shortage problem in this area (Wang et al., 2001; Zhang et al., 2005; Fang et al., 2007; Fang et al., 2010). Improving water use efficiency of wheat and maize production systems and developing optimal water management strategies are urgently needed to deal with the water shortage problem. Numerous experimental and modelling researches have stressed this issue (Zhang et al., 2004; Zhang et al., 2005; Yu et al., 2006; Sun et al., 2006; Fang et al., 2007; Fang et al., 2010; Li and Yu, 2007).

However, there was an increasing demand of forage cultivation in the NCP in the last decade due to food structure change and stock raising development, especially in the Shandong province (Lu and Sun, 2002; Lin, 2004; Liu and Qiao, 2004). There is insufficient research in measuring water use patterns of forage cultivars compared to crop water usage research (Pan et al., 2007). This may have impeded farm level decision making. To provide policy makers with information on suitable forage cultivars and on the optimal irrigation management options in NCP, we need to measure water demands during the growing season specific for each forage cultivars. The approach to measure forage water requirement is similar to field crops, which is based on soil water balance equation. Soil water content was measured normally using a neutron moisture meter (Latta et al., 2001; Latta et al., 2002). Lysimeters were another suitable tool for measuring evapotranspiration for crops and forage. Mueller et al. (2005) quantified water use efficiency of different crops by using groundwater lysimeter in the vicinity of Berlin and found out that the highest WUE occurred with the highest crop biomass. Wei and Ren (2005) summarized some researches of forage water use patterns in China, for example, Xiong et al. (2003) determined that alfalfa consumed 4.15 mm water per day by the pot experiment. Wan et al. (2004) compared WUE of twelve alfalfa cultivars in Shaanxi Province in China through field experimental studies from 2001 to 2002. These studies provided useful understanding, but all the results were from experiments carried out with limited number of years. And there are a few experiments that may have quantified forage water requirements under high inter-annual variations of rainfall.

The water demand of crops and forages is greatly linked to climate through precipitation and atmospheric evaporation demand. Researchers worldwide are paying more and more attention on the influence of climate change on crop yield (Gholipour, 2007; Harmsen et al., 2009; Chen et al., 2010; Yang et al., 2011). The climate in the NCP is dominated by monsoon, which may cause high variation of rainfall at seasonal and inter-annual scales.

The water deficit is especially obvious during the winter wheat growing period (winter and spring), as the region is dominated by temperate monsoon climate, with 75% rain falling mainly between June and September during the maize growing seasons. Precipitation had the biggest variability in the NCP from the analysis of forty years' (from 1961 to 2000) climate data (Chen et al., 2010). So it is necessary to measure the water demand of forage varieties under different climate conditions (especially precipitation).

Therefore, the objectives of this study were to quantify the evapotranspiration, irrigation demand and water use efficiency of seven forage varieties under variable climate (especially precipitation). Suggestions for sustainable forage production in the NCP were proposed based on the research results of this study.

Materials and Methods

Experimental site

The experimental studies were carried out from 2005 to 2009 at Yucheng Integrated Experimental Station of Chinese Ecological Research Network (CERN), Yucheng County, Shandong Province, NCP (36°49'52''N, 116° 34'19''E, and 23 m a.s.l.) (Figure 1). It is located in an alluvial plain of the Yellow River with a temperate monsoon climate. The mean annual precipitation at this station over the past 58 years is 580.6 mm (1951-2008), with a minimum of 279.4 mm (2002) and a maximum of 1027.7 mm (1964). Nearly 75% rain falls within the period of June to September, the maize growing seasons. The mean annual air temperature is 13.1 °C, with the minimum and maximum temperature of -22.0 and 47.7 °C. The soil was formed from the sediments deposited over time by the Yellow River and is calcareous and rich in P and K. The main soil type is silty loam with an average bulk density of 1.43 g cm⁻³. The dominant cropping system in the region is a winter wheat-summer maize rotation system (two crops a year). Farmers usually apply N rates of about 400 to 600 kg N ha⁻¹ yr⁻¹ to the system to maintain high yield in this region.

Design of water budget system

(1) Lysimeters

Fifteen irrigated lysimeters were designed to measure evapotranspiration (ET) of seven forage varieties with three replications for each type of forages during April 2005-September 2009. Lysimeters in number 6 plot is for cup plant and number 14 for alfalfa, 7, 9 and 13 for annual grass rotation system (Figure 1). Each lysimeter is 0.3 m² (0.616 m diameter) in surface area and 0.8 m in depth, with a mesh of cone-shaped cylinder at the bottom (Cheng et al., 1994; Cheng et al., 2002) (Figure 2). There is a catheter at the bottom in order to keep the drainage flow from the lysimeter. Each upper layer of the cone is a filtration layer. It contained, from the base upwards, gauze shops, 5 cm of gravel and 5 cm of sand, then 60 cm (20-80 cm from the surface) backfilled soil, backfilled soil 20 cm (0-20 cm from the surface) soil, which were repacked to obtain bulk densities similar to that of the surrounding field. The seepage water from the lysimeter flows through the catheter then collected in the kegs with a petiole inside the leaking barrel.

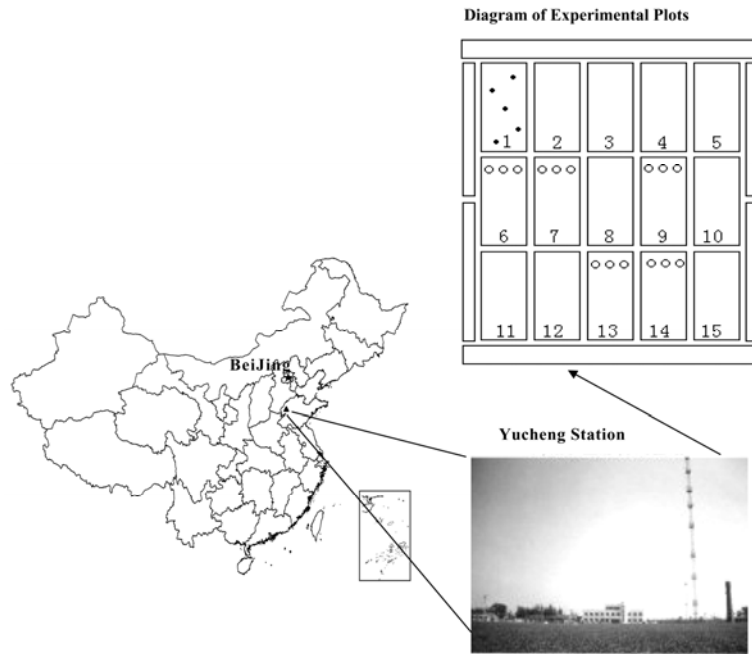

Figure 1. The location of Yucheng Comprehensive Experimental Station (YCES) in the North China Plain and schematic diagram of experimental plots. The figures represent for the experimental plot number, ● represents soil samplings, five soil samples mixed into one, and ○ represents irrigated lysimeters.

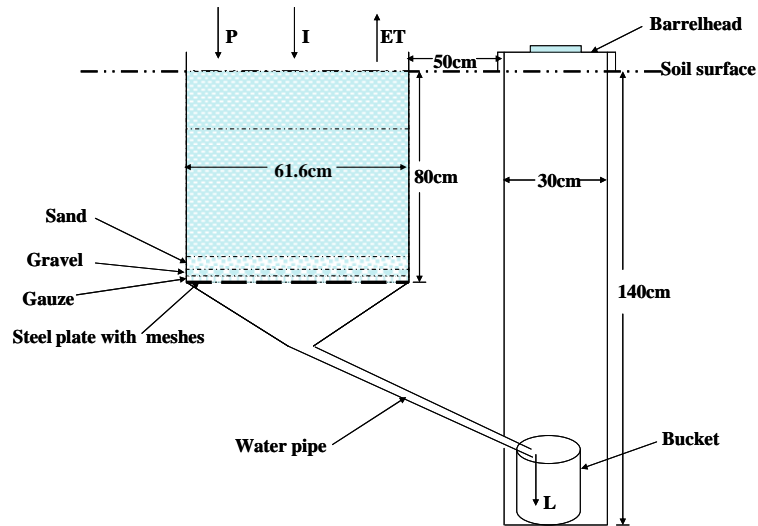

Figure 2. Schematic diagram and water balancing of irrigated lysimeter. Soil was re-filled in the depth of 20-80 and 0-20 cm from the bottom to the top.

(2) Water budget calculation

The evapotranspiration was calculated based on the following soil water balance equation (Equation 1):

$$ET = P + I - F - L + \Delta W \quad (1)$$

Where ET is the evapotranspiration, P the precipitation (mm), I is the irrigation (mm), F is the surface runoff (mm), L is drainage (mm) and ΔW is the change in soil water content (mm).

Irrigation management in the lysimeter aimed to maintain the soil moisture around 70% of field capacity (FC) to avoid water stress at forage growing period. All lysimeters were irrigated till the superfluous water drained to the kegs at the beginning of forage cultivars sowing. At that time soil water content became to FC. Irrigation occurred when soil water content dropped to around 70% of FC. Water content was monitored by the evaporation of 20 m² evaporation pond in the station.

FC is 32% in this region, so there needs 256 mm total amount of water required to the soil in the lysimeter reached saturation. When the soil water content down to 80% of FC in the lysimeter, that is equal to 51.2 mm evapotranspiration, 70% of FC is 72.8 mm. When the total evaporation of 20 m² evaporation pond reaches 51.2 to 72.8 mm, irrigation provided to the lysimeters. Soil water content at the beginning and end of the observation is at FC. As a result,

$$\Delta W = 0 \quad (2)$$

There is no surface run off occurred in the lysimeters. Therefore, L and ΔW were treated as zero in this study. So Equation 1 can be simplified into to Equation 3:

$$ET = P + I - L \quad (3)$$

where ET is the forage evapotranspiration, P the precipitation during the observation period, measured by rain gauges in the meteorological station (about 2 m from the experiment site), I is the irrigation, added manually by certain volume of containers (500 cm³, 10000 cm³, 20000 cm³), the amount was recorded when irrigation applied, L is drainage, measured with graduated cylinder. All terms in Equation 3 are expressed in mm.

(3) Irrigation requirement

The irrigation requirement (I) was calculated by the difference between water demand and rainfall (Equation 4):

$$I = ET - P \quad (4)$$

Where I is the irrigation requirement (mm), ET is the evapotranspiration, P the precipitation (mm) over the same period. Irrigation requirement can provide the basis for the amount of irrigation.

(4) Water use efficiency

In this study, water use efficiency (*WUE*) is defined below:

$$WUE = Y/ET \quad (5)$$

Where *WUE* ($\text{Kg ha}^{-1} \text{mm}^{-1}$) is water use efficiency calculated with seasonal crop water use based on evapotranspiration (*ET*, mm) and *Y* - crop yield ($\text{t ha}^{-1} \text{y}^{-1}$).

Materials and Management

Winter wheat-summer maize rotation was the previous cropping system and corn stubble remained in the field before the study was conducted. A system of water budget and forage production for seven varieties of forage (i.e., annual ryegrass, triticale, sorghum hybrid sudangrass, ensilage corn, prince's feather for annual varieties, and alfalfa, cup plant for perennial varieties, Table 1) was designed under ample water supply. Two cropping systems were established: (i) two continuous perennial grass (alfalfa and cup plant) systems and (ii) annual grass rotation system. Cup plant was planted in plot number 3, 6 and 12, and plot number 4, 8, 14 are for alfalfa, the remaining plots are for annual grass rotation systems (Figure 1).

Table 1. Information on varieties, sowing and management for experimental studies (2005-2009).

Forage	Variety	Seeding Date	Seeding Method	Spacing of Row (cm)	Mowing Stage	Stubble Height (cm)	Harvest times
		Y-M-D					
alfalfa	WL323HQ	2005-4-27	sowing in rows	30	Early flowering (10% bloom)	4~5	3 [†]
cup plant	common species	2005-4-27	sowing in rows	50	50-70 height	5~10	2 [‡]
sorghum hybrid sudangrass	runbao	2005-4-27	sowing in rows	40	140 height	5	2
	runbao	2006-6-3					2
	chaoji-2	2007-5-18					2
	chaoji-2	2008-5-20					2
	chaoji-2	2009-5-24					2
prince's feather	common species	2005-4-27	sowing in rows	40	60-80height	20~30	2
		2006-6-3					2
		2007-5-18					2
		2008-5-20					2
		2009-5-24					2
ensilage corn	xinqing-1	2005-4-27	spot-planting	60	dough stage	0	1
	keduo-4	2006-6-3					1
	keduo-4	2007-5-18					1
	sibao-1	2008-5-20					1
	sibao-1	2009-5-24					1
ryegrass	Wintergrazer-70	2005-10-18	sowing in rows	20	Jointing	5	2
	Wintergrazer-70	2006-9-14					2
	Wintergrazer-70	2007-10-17					2
	Wintergrazer-70	2008-10-11					2
	Wintergrazer-70	2009-9-23					2
triticale	triticale -830	2005-10-18	sowing in rows	20	Jointing	5	2
	triticale -830	2006-9-14					2
	triticale -830	2007-10-17					2
	triticale -830	2008-10-11					2
	triticale -830	2009-9-23					2

Note: 1. [†] harvested 4 times in 2007, [‡] harvested only once in 2005.

Note: Total phosphorus stand for P_2O_5 , Total potassium stand for K_2O , n=15.

The system includes 15 plots (each 5 m × 10 m, 5m EW, 10m NS), in a randomized design with three replicated for each cultivar. Lysimeters were installed in five plots, three in one plot, for replication. Well water was extracted for the experimental plots irrigation. The salinity of the well water is less than 1 g L⁻¹. Amount of 180.8 kg P₂O₅ ha⁻¹, 66 kg K ha⁻¹ and 92.4 kg N ha⁻¹ were applied before planting. These amounts of fertiliser are in accord with local farmers practice. Initial soil physicochemical properties were determined at the beginning of emergence (Table 2). Water was irrigated to the plots using a ground water flow system drawing from the well by the experiment field. The amount of water applied was measured using a flow meter. Fertilizer application was based on the average level of local farmers. Weeds were removed manually, whereas pesticides and herbicides were not applied in the study fields. Management for cultivation and fertilizer of lysimeters was the same as the surroundings plot.

Table 2. Initial soil physicochemical properties (Sampling 2005-5-18).

Soil	Organic	Total	Total	Total	Conductivity	Salinity	
Depth (cm)	Matter (%)	Nitrogen (%)	Phosphorus (%)	Potassium (%)	(ms/cm)	(%)	pH
0-20	1.32±0.14	0.08±0.01	0.19±0.03	2.35±0.12	0.36±0.04	0.11±0.01	8.52±0.07
20-40	0.87±0.20	0.05±0.01	0.15±0.02	2.36±0.06	0.22±0.03	0.07±0.01	8.77±0.04

Observations and measurements

(1) Crops (biomass, LAI, and phenology)

Aboveground biomass and green leaf area index (LAI) were determined by hand-cutting 30 cm in length of single row for annual ryegrass and triticale, 3 stalks for others of each plot every 5-10 days. Plant samplings were detached into several parts, i.e. stems, green leaves, withered leaves and spikes. The dry weight of each part was measured after drying in a controllable oven (firstly deactivated enzymes at 105 °C for 1.5 hours, then at 75 °C for about several hours until drying, that brought to a constant weight. It took 8h for ryegrass and triticale and 48 h or longer for others. LAI (for green leaves) was measured using the LI-3000C Portable Area Meter in combination with the LI-3050C Transparent Belt Conveyer Accessory. 1 m × 3 rows plants were chosen for average plant height determination (20 data were recorded), consistent with the frequency of biomass.

Forage yield was obtained by manually harvesting 2 m × 3 rows section randomly selected in the plot at suitable mowing stage (Table 1). Forage yield as determined by oven drying weight of samples. Forage phenology was observed every 5 days.

(2) Soil water (method and instruments)

Soil water content of the plot was measured every 7-10 days (10 days for winter season, 7 days for others) from an aluminium access tubes in each plot by using a moisture meter (CNC503DR, Beijing Nuclear Security Nuclear Instrument Co., Ltd.) The measurement of the five plots (with lysimeters in) was from the depth of 20 to 140 cm with 20 cm measurement intervals, while others from 20 to 100 cm in depth with 20 cm intervals.

Weather data are from the Bureau of Meteorology of Yucheng County. There is large inter-annual variability of monthly rainfall across experimental years (Figure 3). However, the inter-annual variability of monthly temperature is small for the period of 1961 to 2005 (Figure 4). Accordingly, we classified climate patterns for the experiment years on the basis of the characteristics of inter-annual precipitation.

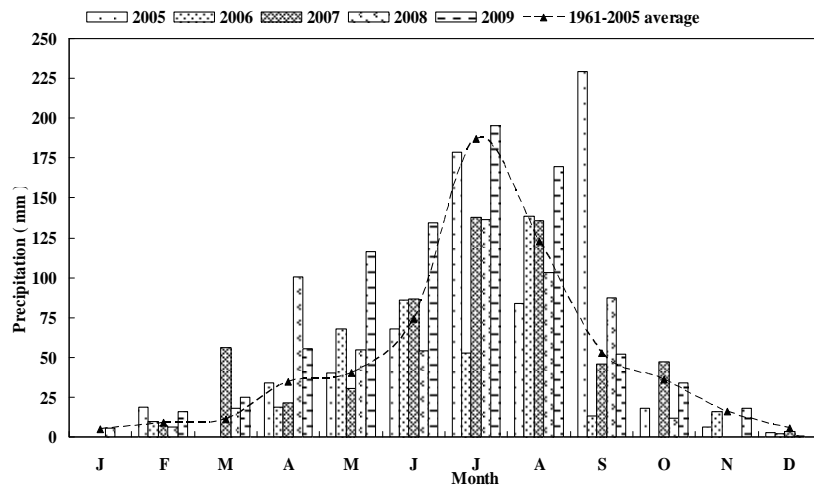

Figure 3. Monthly precipitation of for experimental years (2005-2009) and long-term average over 1961-2005 at Yucheng. Blank column denotes no rainfall.

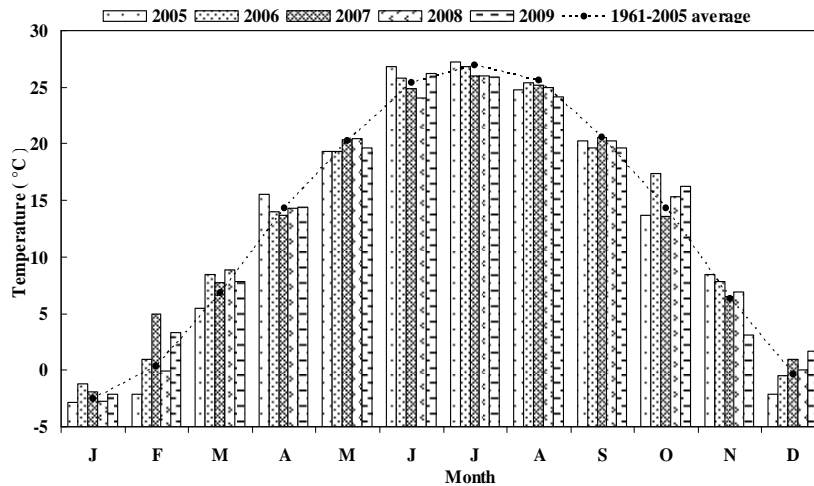

Figure 4. Monthly temperature for experimental years (2005-2009) and long-term average over 1961-2005 at Yucheng Station.

Results

Evapotranspiration (ET) under different climate patterns

Average annual precipitation at experiment area for the period of 1951-2005 (55 years) is 580.4 mm. These years were divided into three climate patterns (dry, wet and normal years) with different conditions that correspond to forage cultivars growing period (Table 3) and also to the study years (Table 3 note). Average ET for five annual varieties ranged from 333 to 371 mm with no statistical differences found between them, while it is significantly lower than that of the perennial varieties ($P=0.05$, Table 4). Average ET for perennial varieties alfalfa is 789 mm, which is 188 mm higher than that of cup plant and the difference is statistically different ($P=0.05$, Table 4). ET of each forage cultivar varied under different climate patterns with wet years has the lowest ET, except ryegrass, triticale and sorghum hybrid sudangrass. Annual varieties consumed more water on a daily basis under low rainfall situation than in normal and wet years, while the perennial forages consumed the most water under normal years followed by dry and wet (Figure 5). Ryegrass and triticale need 1.5 to 2.0 mm water per day, while cup plant and alfalfa require 2.9-4.4 mm, the rest needs 3.0-4.4 mm. Results showed that annual varieties matured earlier under dry condition than under wet condition. Ryegrass and triticale matured 2-10 days earlier in the dry years than in the other years. The maturing date of sorghum hybrid sudangrass and ensilage corn was advanced 2-13 days. Prince's feather advanced 28-76 days and the same result has been obtained by Fasinmirin et al. (2009). They noticed that some *Amaranthus cruentus* reached maturity earlier than normal when water stress exists at the sensitive stage of crop growth.

Table 3a. Classification of long-term (1951-2005) annual rainfall.

Climate patterns	annual precipitation
wet years	≥ 696.5 mm
normal years	<696.5 mm, >464.4 mm
dry years	≤ 464.4 mm

Note: Definition of climate patterns: wet year, annual rainfall greater than or equal to 120% of the average for the past 55 years (1951-2005); normal years, rainfall between 120% and 80% average; dry years, rainfall less than or equal to 80% average. Annual precipitation (mm): 2005, 678.4; 2006, 403.6; 2007, 571.7; 2008, 579.1 and 2009, 816.4.

Table 3b. Ryegrass and triticale growing season (from October previous year to April the year after) climate patterns.

Type of the year	precipitation
wet years	≥ 133.8 mm
normal years	< 133.8 mm, >80.3 mm
dry years	≤ 80.3 mm

Note: Wet year, rainfall greater than or equal to 125% of the average for the past years (1951-2005); normal years, rainfall between 125% and 75% average; dry years, rainfall less than or equal to 75% average. Rainfall (mm): 2005-2006, 54.4; 2006-2007, 102.3; 2007-2008, 182.0 and 2008-2009, 109.1.

Table 3c. Ensilage corn yearly growing season (May to September) climate patterns.

Type of the year	precipitation
wet years	≥ 592.9 mm
normal years	<355.7 mm, >592.9 mm
dry years	≤ 355.7 mm

Note: Wet year, rainfall greater than or equal to 125% of the average for the past years (1951-2005); normal years, rainfall between 125% and 75% average; dry years, rainfall less than or equal to 75% average. Rainfall (mm): 2005, 599.3; 2006, 357.5; 2007, 436.5; 2008, 435.4 and 2009, 668.2.

Table 4. Evapotranspiration (ET) under different climate patterns (mm).

Forage	wet years	normal years	dry years	all years
triticale	353	362	310	347 ^a
ryegrass	405	356	349	366 ^a
prince's feather	312	354	333	333 ^a
sorghum hybrid sudangrass	382	329	378	360 ^a
ensilage corn	355	372	402	371 ^a
cup plant	517	652	668	601 ^b
alfalfa	721	842	821	789 ^c

Values with the same letter were statistically similar at a level of significance of 0.05, based on the one-way ANOVA test by SPSS Statistics 17.0.

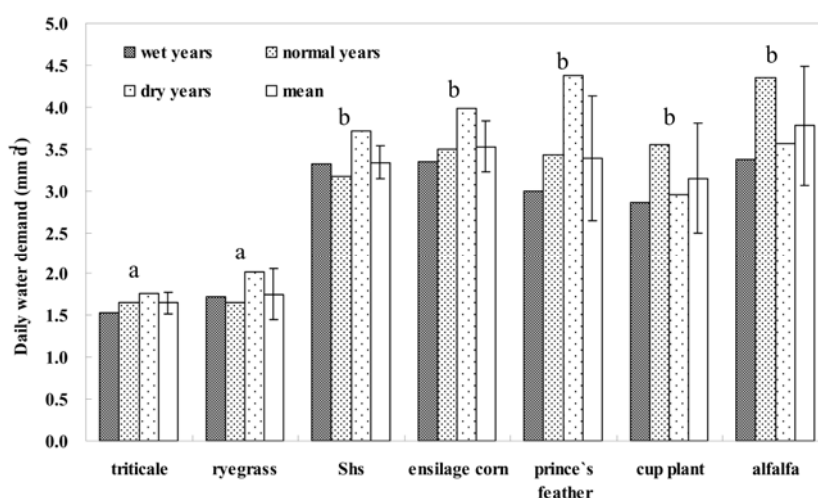

Figure 5. Average daily water use of forage cultivars under different climate patterns.

† Shs represents sorghum hybrid sudangrass. Values with the same letter were statistically similar at a level of significance of 0.01, based on the one-way ANOVA test by SPSS Statistics 17.0.

Irrigation requirement under each climate pattern

Irrigation requirement was calculated as the difference between ET and rainfall during growing period as showed in Table 5. Ryegrass and triticale need 222-281 mm and 170-256 mm of irrigation water respectively across all seasons to maintain growth and achieve better production. The irrigation requirement of ryegrass is 242 mm, which is 39 mm higher than that of triticale in dry years and their difference is statistically significant ($P=0.01$, Table 5). Sorghum Hybrid Sudangrass needs a small amount of irrigation in the dry seasons and no irrigation in other seasons. Irrigation amount for each cultivar varied under different climate patterns. Prince's feather, ensilage corn and cup plant do not need irrigation in the wet seasons, but require small amount of irrigation in the normal years and require relatively large amount of irrigation water in the dry years. Ryegrass needs higher irrigation amount in dry years compared with normal and wet conditions. Alfalfa still needs 22 mm irrigation water in the wet seasons, 380 mm in the normal seasons, and 445 mm in the dry seasons.

Table 5. Irrigation demand for each climate patterns (mm).

Forage	wet years	normal years	dry years
sorghum hybrid sudangrass	0	0	89 ^a
ensilage corn	0	41	113 ^a
prince's feather	0	23	152 ^b
triticale	170	256	242 ^c
ryegrass	222	251	281 ^d
cup plant	0	177	292 ^d
alfalfa	22	380	445 ^e

Values with the same letter were statistically similar at a level of significance of 0.01, based on the one-way ANOVA test by SPSS Statistics 17.0.

Water use efficiency

The law of water use efficiency for each forage variety under different climate patterns is consistent with the dry weight of biomass (Table 6 and Table 7). WUE for ryegrass and triticale under dry condition is higher than normal years, lowset in wet years. WUE for sorghum hybrid sudangrass and prince's feather in wet years is higher than that of dry years, followed by normal years, while WUE in dry years is higher than other conditions for alfalfa and cup plant. Ensilage corn has the highest WUE (62.0 Kg ha⁻¹ mm⁻¹) in normal years compared with the other varieties, but there is no statistical difference among them. WUE over the five years for prince's feather is 20 Kg ha⁻¹ mm⁻¹ under analysis, for ensilage corn is 41 Kg ha⁻¹ mm⁻¹ while for other fiver cultivars is close to 26 Kg ha⁻¹ mm⁻¹.

Table 6. Water use efficiency (WUE) under different climate patterns (Kg ha⁻¹ mm⁻¹).

Forage	wet years	normal years	dry years	all years
triticale	21	21	34	24
ryegrass	17	27	31	25
prince's feather	29	14	17	20
sorghum hybrid sudangrass	36	24	28	29
ensilage corn	29	62	26	41
alfalfa	20	14	52	24
cup plant	15	37	38	28

Table 7. Dry biomass for each climate patterns (t ha⁻¹ y⁻¹).

Forage	wet years	normal years	dry years	all years
triticale	7.3	7.8	10.6	8.4
ryegrass	6.7	9.4	10.7	9
prince's feather	9.3	4.9	5.5	6.8
ensilage corn	9.7	23.1	10.6	15.2
sorghum hybrid sudangrass	13.1	7.7	10.6	10.5
cup plant	7.2	22.3	25.3	16.9
alfalfa	13.9	11.4	42.6	18.6

Discussion and Conclusion

Understanding the balance between water supply and irrigation requirement under different climate types is critical for ensuring sustainable water use in the NCP. This study determined water use and WUE of seven forage cultivars in three climate conditions in the NCP based on 5 years experimental study.

Based on long term rainfall record (for spring and summer/ autumn seasons), ensilage corn is the best choice due to its highest forage yield and WUE in summer. This result is consistent with the conclusion of Mueller's groundwater lysimeter experiment (Mueller et al., 2005). Sorghum hybrid sudangrass is another forage cultivar grew well in all the climate conditions. It's irrigation demand in the dry seasons is smaller than others and the difference is significant at the level of 0.01 (Table 5). Prince's feather is sensitive to soil water deficit and only achieve the highest yield and WUE in wet seasons. So it can be used when growing season rainfall is greater than 592.9 mm during the growing period.

Yang et al. (2000) reported that winter wheat needs 154.8-318.2 mm irrigation water by the 30 Mg weighing lysimeter in the Yucheng station, CAS. Based on our measurement, ryegrass and triticale need 170-281 mm irrigation water, which is close to the winter wheat demand. So incorporating ryegrass and triticale into the cropping system in the NCP is feasible if optimal water resources strategies are in place. As cotton is the third primary crop in NCP, ryegrass and triticale can be grown in the fallow phase after cotton's harvest. From 1998 to 2008, cotton production area is about $1.9\sim 3.6 \times 10^6$ ha in the NCP, which is 3.8~7.0% for the sowing acreage and coverage (Ministry of Agriculture, China Agriculture Yearbook Editorial Committee, 1999-2009). Cotton production provides opportunities for the growth of ryegrass and triticale. This can both improve the utilization of resources of the fallow fields and also meet the shortage of green feed in winter and early spring in the region. In the dry years triticale is better than ryegrass in terms of its significantly lower irrigation requirement.

For perennial varieties, cup plant performed better than alfalfa in terms of water consumption. Their difference is statistically different. Wan et al. (2004) found that ET of alfalfa reached 666.6 mm and its WUE was $21.52 \text{ Kg ha}^{-1} \text{ mm}^{-1}$ under rainfed conditions. Alfalfa consumed 721 mm water in wet conditions and its WUE was $20 \text{ kg ha}^{-1} \text{ mm}^{-1}$ based on our measurement. Our experiments under different rainfall conditions indicate that alfalfa can achieve higher biomass and WUE under arid climate conditions with ample irrigation, but excessive rain will reduce the production.

The results of this experiment have implications for researchers and decision/policy makers concerned with water consumption and management of forage cultivars in the NCP. Research results from this study will be very useful in addressing climate change impact and adaptation issues, topic areas of current research and policy.

Acknowledgement

We acknowledge the great contribution of LI Bin in assisting the experiment as well as data collection and management. We note also the support of other members of the staff of Yucheng Integrated Experiment Station and their assistance in many aspects of the work involved in the construction and operation of the lysimeters. We are indebted to CHENG Weixin, MA Liwang, FANG Quanxiao and Timothy Green for their valuable advice and help. The work was supported by the Knowledge Innovation Program of the Chinese Academy of Sciences (Grant No. KSCX2-YW-N-46-01).

References

- Chen, C., Wang, E.L., Yu, Q., 2010. Modelling the effects of climate variability and water management on crop water productivity and water balance in the North China Plain. *Agric. Water Manag.* 97 (8), 1175-1184.
- Cheng, W.X., Hu, C.B., Zhang, X.Q., 1994. Evaporation and crop water consumption of agricultural research. Meteorological Press, Beijing. (In Chinese)
- Cheng, W.X., Kang, Y.H., 2002. Measuring method of water consumption and water requirement of lawn in Beijing area. *Water Saving Irrigation*, 5, 12-14. (In Chinese with English abstract)
- Fang, Q.X., Chen, Y.H., Qiang, Yu., Ouyang, Z., Li, Q.Q., Yu, S.Z., 2007. Much improved irrigation use efficiency in an intensive wheat-maize double cropping system in the North China Plain. *J. Integr. Plant Biol.* 49 (10), 1517-1526.
- Fang, Q.X., Ma, L.W., Qiang, Yu., et al., 2010. Irrigation strategies to improve the water use efficiency of wheat-maize double cropping systems in North China Plain. *Agric. Water Manag.* 97 (8), 1165-1174.
- Fasinmirin, J.T., Olufayo, A.A., Oguntunde, P.G., Oguntuase, A.M., 2009. Parametrizing simple model between yield and evapotranspiration for *Amaranthus cruentus* under drip and sprinkler irrigations. *Int. J. Plant Production*, 3 (1), 75-90.
- Gholipour, M., 2007. Potential effects of individual versus simultaneous climate change factors on growth and water use in chickpea. *Int. J. Plant Production*, 2, 189-204.
- Harmsen, E.W., Miller, N.L., Schlegel, N.J., Gonzalez, J.E., 2009. Seasonal climate change impacts on evapotranspiration, precipitation deficit and crop yield in Puerto Rico. *Agric. Water Manag.* 96, 1085-1095.
- Latta, R.A., Cocks, P.S., Matthews, C., 2002. Lucerne pastures to sustain agricultural production in southwestern Australia. *Agric. Water Manag.* 53 (1-3), 99-109.
- Latta, R.A., Blacklow, L.J., Cocks, P.S., 2001. Comparative soil water, pasture production and crop yields in phase farming systems with lucerne and annual pasture in Western Australia. *Aust. J. Agric. Res.* 52, 295-303.
- Li, L.H., Qiang, Yu., 2007. Quantifying the effects of advection on canopy energy budgets and water efficiency in an irrigated wheat field in the North China Plain. *Agric. Water Manag.* 89, 116-122.
- Lin, Z.A., Xu, J.X., Ma, X.L., 2004. High quality forage varieties and their efficiency planting pattern. *Crops*, 4, 36-38. (In Chinese)
- Liu, G.B., Qiao, R.F., 2004. The current situation and prospects of forage grasses in Hebei Plain. *Journal of Hebei Agricultural Sciences*, 8 (3), 102-104. (In Chinese)
- Liu, C.M., Zhang, X.Y., Zhang, Y.Q., 2002. Determination of daily evaporation and evapotranspiration of winter wheat and maize by largescale weighing lysimeter and micro-lysimeter. *Agr. Forest Meteorol.* 111, 109-120.
- Lu, L.S., Sun, J.M., 2002. Strategic adjustment of agricultural structure and food security in the new period in China. *Food and Nutrition in China*, 2, 4-7. (In Chinese)
- Ministry of Agriculture, China Agriculture Yearbook Editorial Committee. 1999-2009. *China Agricultural Yearbook*. Beijing: China Agriculture Press.
- Mueller, L., Behrendt, A., Schalitz, G., et al., 2005. Above ground biomass and water use efficiency of crops at shallow water tables in a temperate climate. *Agric. Water Manag.* 75 (2), 117-136.
- Pan, G.Y., Ouyang, Z., Li, P., 2007. Cultivation pattern and development of quality forage in the North China Plain. *Resources Science*, 229 (2), 15-20. (In Chinese with English abstract)
- Sun, H.Y., Liu, C.M., Zhang, X.Y., et al., 2006. Effects of irrigation on water balance, yield and WUE of winter wheat in the North China Plain. *Agric. Water Manag.* 85 (1-2), 211-218.
- Wang, H.X., Zhang, L., Dawes, W.R., et al., 2001. Improving water use efficiency of irrigated crops in the North China Plain-measurements and modelling. *Agric. Water Manag.* 48 (2), 151-167.
- Wan, S.M., Hu, J.Z., Hu, S.L., et al., 2004. The Study on Water Use Efficiency of Alfalfa Cultivars in Weibei High Plateau. *Acta Agriculturae Boreali-occidentalis Sinica*. 13 (2), 133-137. (In Chinese with English abstract)
- Wei, F., Ren, S.M., 2005. Analysis of grass research at present. *Hebei Water Resources and Hydropower Engineering*, 6, 60-62. (In Chinese with English abstract)
- Xiong, W., Wang, Y.H., Cheng, J.M., et al., 2003. Study on Comparison Experiments of Evapotranspiration of Three Herb Species. *Journal of Soil and Water Conservation*, 17 (1), 170-172. (In Chinese with English abstract)
- Yang, J.F., Li, B.Q., Liu, S.P., 2000. A large weighing lysimeter for evapotranspiration and soil water-groundwater exchange studies. *Hydrol. Process*, 14, 1887-1897.
- Yang, X., Chen, Ch., Luo, Q., Li, L., Yu, Q., 2011. Climate change effects on wheat yield and water use in oasis cropland. *Int. J. Plant Production*, 5 (1), 83-94.

- Qiang, Y.u., Saseendran, S.A., Ma, L.W., et al., 2006. Modelling a winter wheat-corn double cropping system using RZWQM and the RZWQM-CE RES Hybrid. *Agr. Syst.* 89, 457-477.
- Zhang, X.Y., Chen, S.Y., Liu, M.Y., et al., 2005. Improved water use efficiency associated with cultivars and agronomic management in the North China Plain. *Agron. J.* 97, 783-790.
- Zhang, Y.Q., Kendy, E., Yu, Q., et al., 2004. Effect of soil water deficit on evapotranspiration, crop yield, and water use efficiency in the North China Plain. *Agric. Water Manag.* 64 (2), 107-122.