



Australian Standards Committee CS-101 Sports and Recreational Equipment from formation to now

Prof David Eager

27 May 2021

Earliest recorded play

- Clay model of a female figure swinging on a swing between two columns
- *Hagia Triada, 1500 -1450 BC*
- (within the Heraklion Archaeological Museum, Crete)



Animals play too

Two squirrels playing in the snow



Birds also play

Birds playing in water



Origin of CS-101

This was published 17 years ago

Death traps on the soccer field

July 6, 2003 – 10.00am

Origin of CS-101

The State Opposition has demanded an urgent review of soccer goalpost safety laws after the latest accident in which a three-year-old girl was killed.

India Verity, of Mittagong in the Southern Highlands, died after portable soccer goalposts came crashing down on her during a family soccer day at Moss Vale last weekend.

She was singing and dancing to her favourite Wiggles song, *Rock-A-Bye Your Bear*, when tragedy struck.

Her father William Verity said yesterday: "India was a girl who loved to dance and it was therefore fitting that was exactly what she was doing when she died. She was so full of life and will be missed by many, many people."

At the same time, another Sydney parent Suzana Malbasa broke down as the news forced her to relive the death of her own son, which occurred in strikingly similar circumstances.

Origin of CS-101

- On the 27 August 2004 the NSW Deputy State Coroner released his findings and recommendations from the inquest into the death of three-year old India Verity who was killed when struck by a falling soccer goal on 6 July 2003
- UTS was engaged by the NSW Department of Fair Trading in December 2004 to conduct collaborative research and on-site impact testing on a variety of soccer goals
- The results of this testing were used to draft the technical component of the Soccer Goal Regulation (NSW)



Origin of CS-101

- The best soccer goals are ones that are permanently fixed into the ground
- Where these are not available, movable goals are used and a standard specifying the safety requirements for movable goals was required
- A test method was developed to address the risk of accidental tip-over or pull-over of the goal
- This test method was published as:
AS 4866.1:2007 Playing field equipment – Soccer goals Part 1: Safety aspects, Standards Australia, 23 November 2007



A chronological list of the published CS-101 Standards

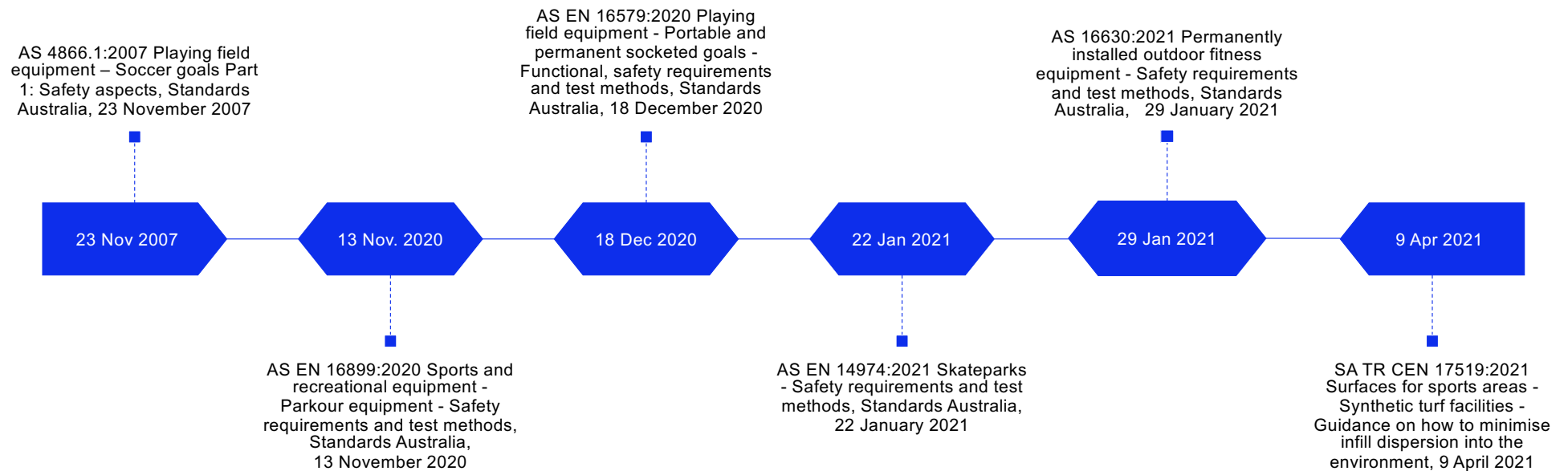

Future CS-101 Standards

- DR AS 19202-1 Summer toboggan runs Part 1: Safety requirements and test methods
- DR AS 19202-2 Summer toboggan runs Part 2: Safety requirements for operation
- ISO 20597 Stationary training equipment (series)
- ISO 20380:2016 Public swimming pools – Computer vision systems for the detection of drowning accidents in swimming pools – Safety requirements and test methods

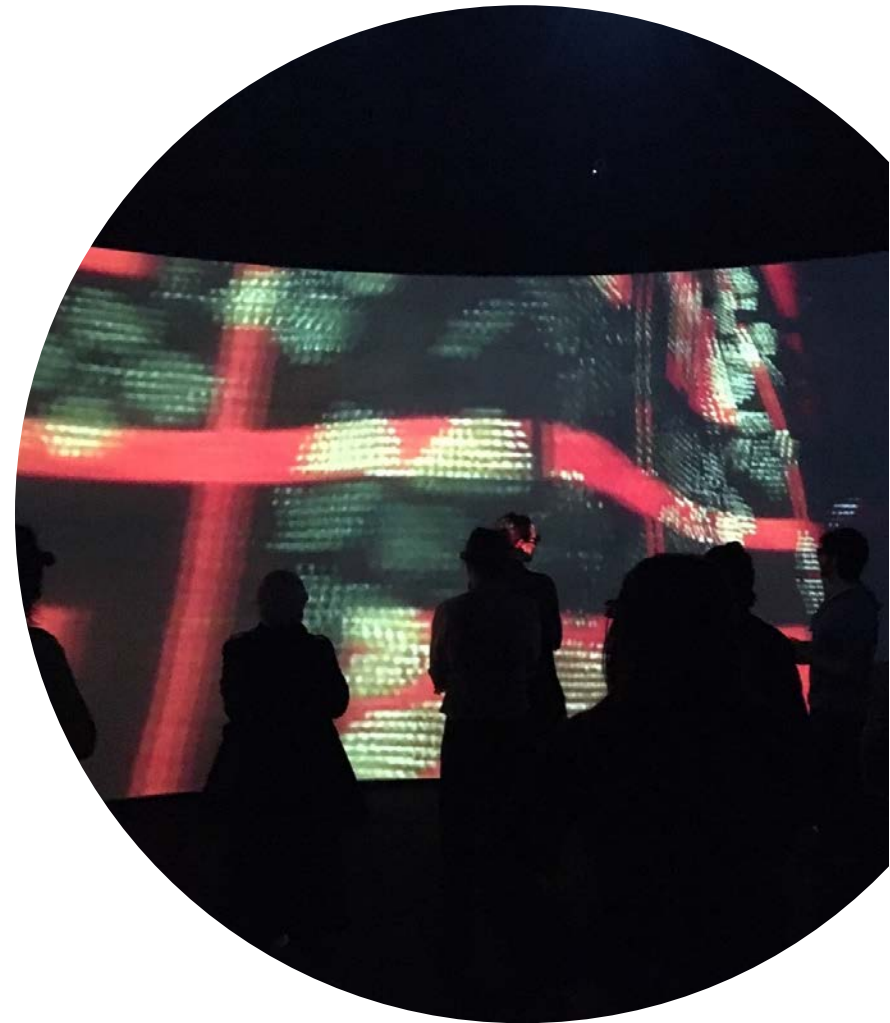

ISO & CEN adoption process

- For CEN Standards there are two choices with adoption 'identical' and 'modified adoption'
- For 'modified adoption' all changes are contained within Appendix ZZ at the end of the document
- This is akin to having the 'Special Conditions of Contract' after the General Conditions of Contract (and hidden at the bottom)
- Australia is a signatory to the Marrakesh Agreement WTO TBT (technical barrier to trade)
- The TBT establishes rules and procedures regarding the development, adoption of standards:
 - Any amendment must be supported by evidence
 - These amendments must be specific to Australia
 - We can only change 'shall' clauses (we are not allowed to change 'should' clauses or 'notes')

AS EN 16899:2020 Parkour equipment

- This Standard specifies the requirements for parkour equipment for use mainly by users starting from 8 years of age
- What is 'parkour'?
- Parkour is also known as 'freerunning' and 'Art du Deplacement'
- Parkour is a non-competitive sport of training where the participant moves freely over and through any terrain using only the abilities of their body
- It includes running, jumping, climbing and quadrupedal movement
- Parkour focuses on developing attributes such as strength, fitness, balance, spatial awareness, agility, coordination, precision, control and creative vision

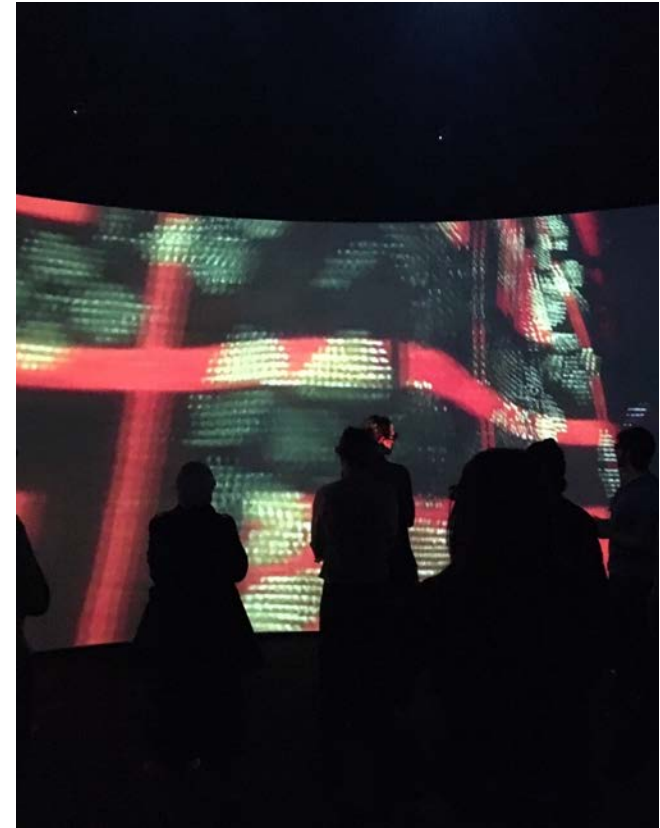

AS EN 16899:2020 Parkour equipment

Important design considerations

- Dynamic loads to the structural integrity must be verified by calculations and/or physical testing
- Stability of the structures
- Material fatigue due to cyclical loading
- Ability filters to restrict access by young children

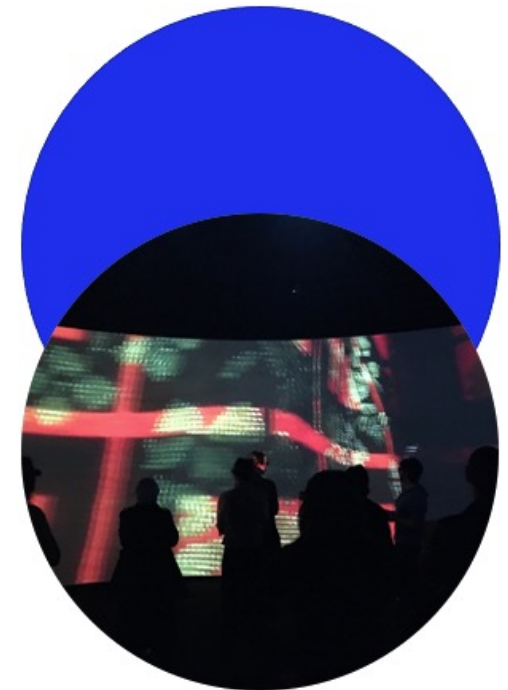

AS EN 16899:2020 Parkour equipment

Access restrictions

- Due to the potential for access by children, parkour equipment shall be designed to make access difficult for young children
- Combination of vertical and horizontal dimensions is used

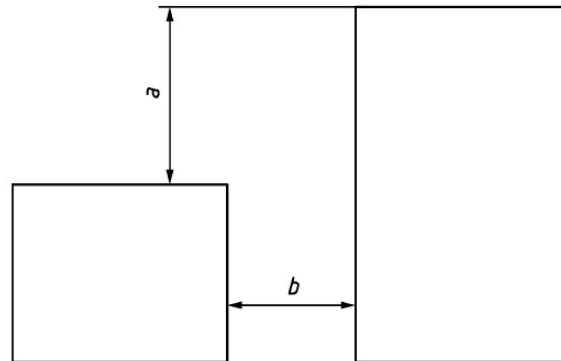

Key

a vertical dimension

b horizontal dimension

NOTE Step = a + b.

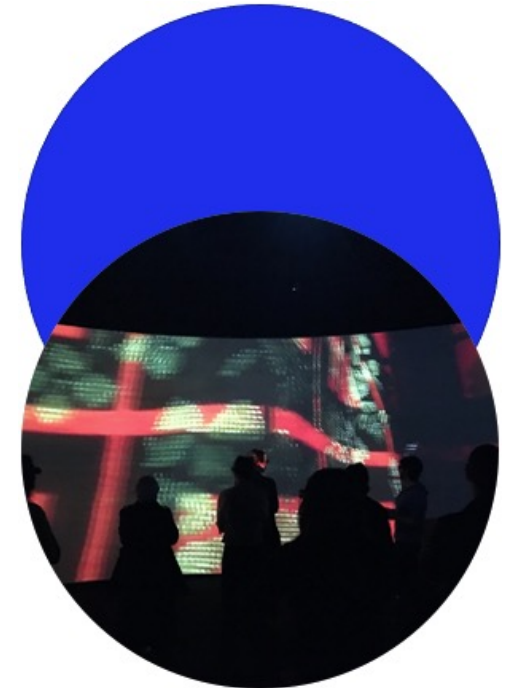

AS EN 16899:2020 Parkour equipment

Access restrictions - rules

- Access to landings in height < 1 m may be easy access
- Access to landings 1 m to 1.5 m require 1 step > 0.7 m
- Access to landings 1.5 m to 3 m require 1 step > 1 m

Step > 1 m required

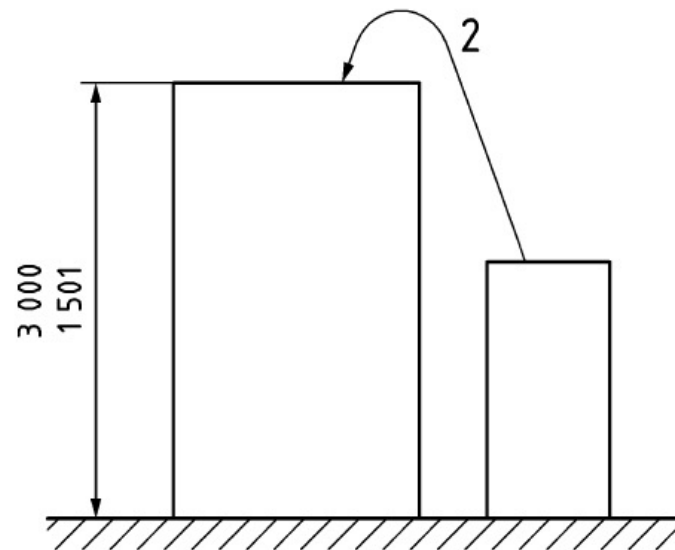

AS EN 16899:2020 Parkour equipment

Free height of fall (FHoF)

- No impact attenuated surface (IAS) below 1.6 m
- Above 1.6 m IAS in accordance with 2/3 x AS 4422

- For example:

FHoF = 2.7 m CFH = 1.8 m

FHoF = 3.0 m CFH = 2.0 m

- Maximum FHoF is the same as AS 4685 i.e. 3.0 m

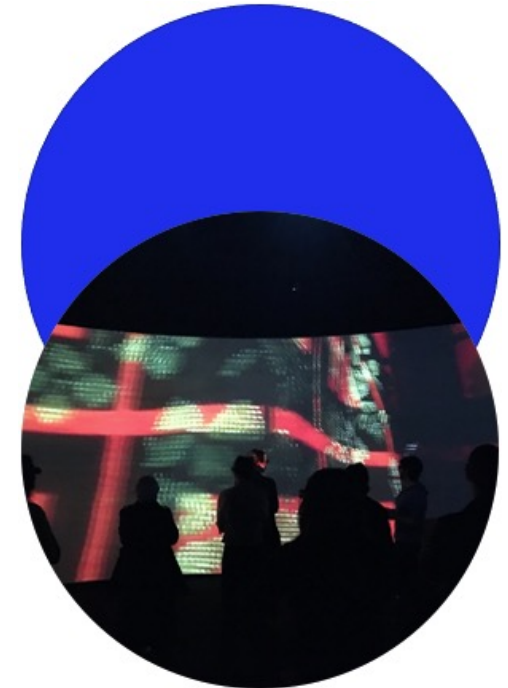

AS EN 16899:2020 Parkour equipment

Extent of the falling space

- Falling space is 1.5 m when fall height is < 1.5 m
- Between 1.5 m and 3.0 m

$$x = 2/3y + 0.5 \text{ m}$$

Where: x is the extent of the falling space

y is the FHoF

- Distance between two solid objects such as blocks, when both are higher than 1.2 m, shall be > 0.55 m

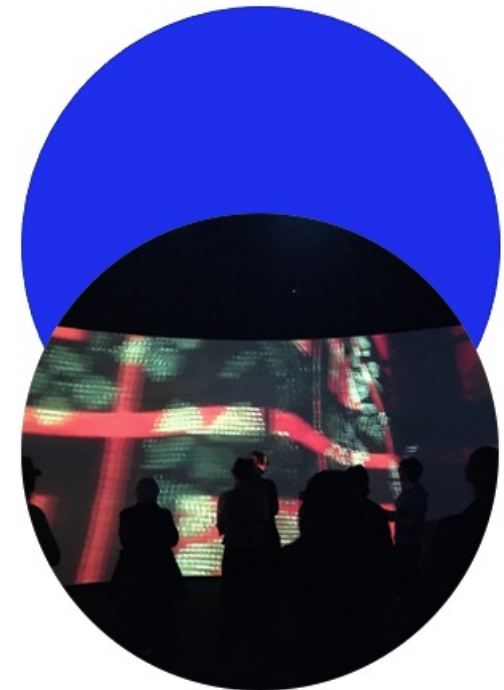

AS EN 16899:2020 Parkour equipment

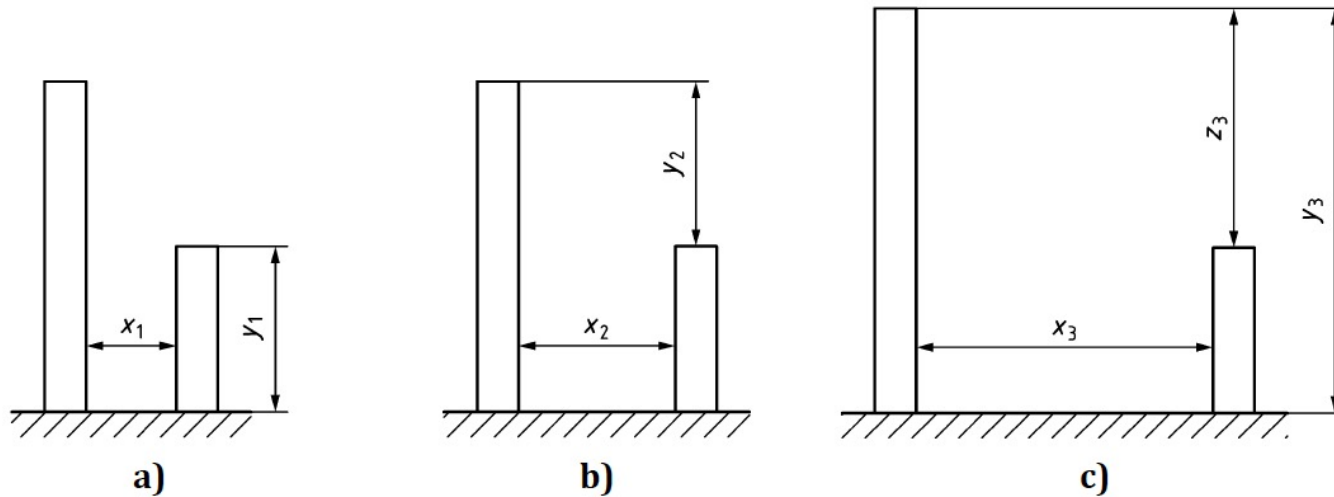

Key

$y_1 > 1\ 200\ \text{mm}$

$x_1 > 550\ \text{mm}$

$x_2 > \text{extent of the falling space calculated from measure } y_2$

$y_2 < 1\ 500\ \text{mm}$

$x_3 > \text{extent of the falling space calculated from measure } y_3$

$y_3 < 3\ 000\ \text{mm}$

$z_3 > 1\ 500\ \text{mm}$

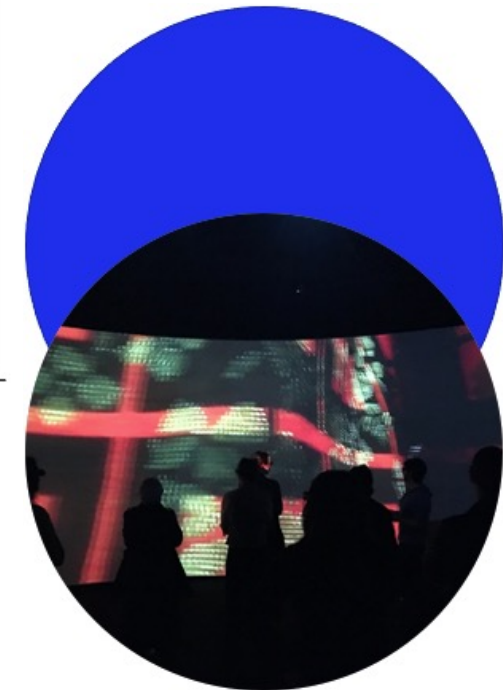

AS EN 16899:2020 Parkour equipment

- Entrapment is essentially the same as AS 4685
- There is also a body clearance test (350 mm x 550 mm)

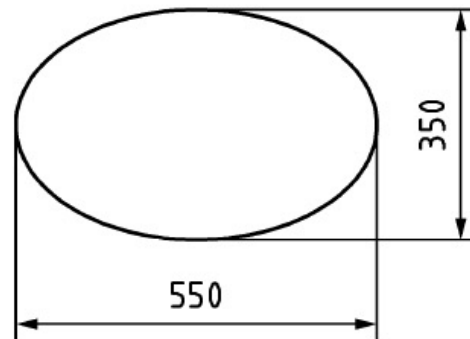

- Finger probe is different too

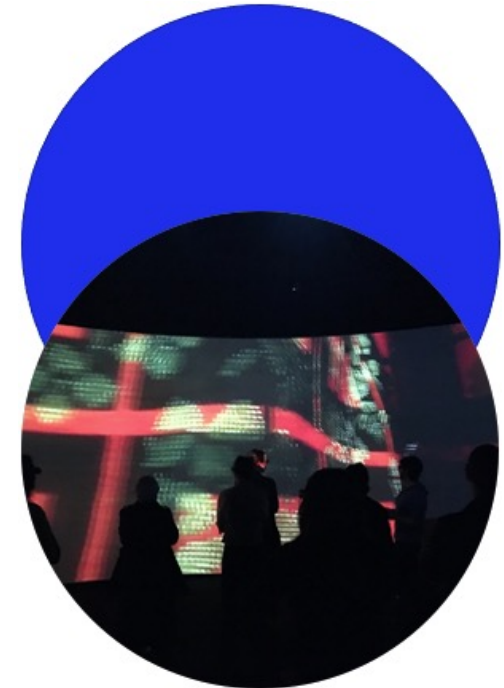
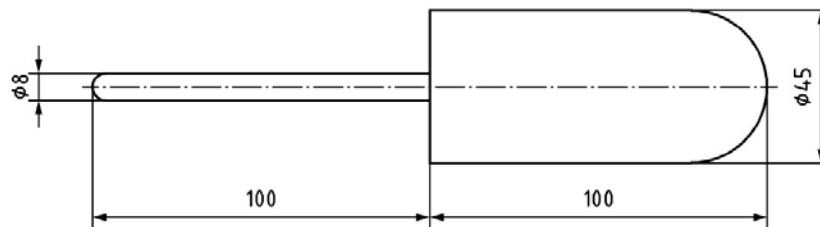

AS EN 16579:2020 Portable and permanent socketed goals

- This Standard supersedes AS 4866.1:2007 with one big exception
- ACCC Mandatory Standard still applies for movable soccer goals:

<https://www.productsafety.gov.au/standards/moveable-soccer-goals>

COMMONWEALTH OF AUSTRALIA

Trade Practices Act 1974

Consumer Protection Notice No. 28 of 2010

CONSUMER PRODUCT SAFETY STANDARD – MOVABLE SOCCER GOALS

I, David Bradbury, Parliamentary Secretary to the Treasurer, pursuant to subsection 85E (1) of the *Trade Practices Act 1974* and for the purposes of section 65C of that Act, hereby:

REVOKE the Consumer Product Safety Standard – Movable Soccer Goals declared in *Consumer Protection Notice No. 23 of 2010* and registered on the Federal Register of Legislative Instruments on 7 July; and

DECLARE that after 30 December 2010 the consumer product safety standard for movable soccer goals that weigh 28 kg or more is the standard approved by Standards Australia specified in Division 1 of the Schedule, as varied by Division 2 of the Schedule.

THE SCHEDULE

Division 1: The Standard

Australian Standard AS 4866.1-2007 *Playing field equipment - Soccer goals - Safety aspects*, published by Standards Australia on 23 November 2007.

Division 2: Variations

AS 4866.1-2007 is varied by

- (i) In clause 1 deleting the words "and indoor arenas";
- (ii) Deleting clause 3;
- (iii) Deleting clauses 5.1, 5.2, 5.3(a), 5.3(b), 5.3(c) and 5.3(d);
- (iv) Deleting the text of clause 5.3(f) and replacing with the following: "Goals shall be provided with an effective ground anchor system and instructions on the use of the system. At least one anchor point shall be provided at each side of the rear ground bar.";
- (v) Deleting Figure 2
- (vi) Deleting clauses 5.4 and 5.5;
- (vii) In clause 5.6.1(a) deleting the words "produce an impact force of less than 200 N when tested in accordance with Clause 6.1(a), and";
- (viii) Deleting clause 5.6.1(b);
- (ix) Deleting clauses 5.6.2, 5.6.3 and 5.7;
- (x) Deleting clauses 6.1(a), 6.1(c) and 6.2;
- (xi) Modifying clause 6.3.1(a) by deleting the words "without pegs, stakes or other forms of temporary anchoring device" and replacing with the words "using the recommended minimum ground anchors";
- (xii) Modifying clause 6.3.1(b) by deleting the word "2000 N" and replacing with "1100 N";
- (xiii) Deleting clauses 6.3.2, 7 and 8;
- (xiv) Delete clause 9 and replace with the following:
"9 WARNING LABELS
Movable soccer goals must have the following warning permanently marked clearly and legibly with upper case letters at least 25 millimetres high and lower case letters at least 12.5 millimetres high:

"WARNING—ALWAYS ANCHOR GOAL—NEVER CLIMB OR HANG ON CROSSBAR. Unanchored goals can tip over causing serious injury or death."

The warning labels shall be placed in three positions on the goal - on the underside of the crossbar and the outside of both goal upright posts.;
- (xv) In the examples provided in Figure 4, deleting "Unsecured goal" and replacing it with "Unanchored goals"; and
- (xvi) Deleting clauses 10, and 11.



AS EN 16579:2020 Portable and permanent socketed goals

- AS EN 16579:2020 is not limited to outdoor soccer goals
- AS EN 16579:2020 covers all portable and socketed goals ranging in weight from 10 kg to 42 kg (there are some exceptions where goals are covered by specific CEN Standards such as:
 - EN 748 (football aka soccer with 5 m wide goals)
 - EN 749 (handball)
 - EN 750 (hockey)
 - EN 1270 (basketball and related sports)
 - EN 13451 (water polo)
 - EN 16664 (lightweight goals)



AS EN 16579:2020 Portable and permanent socketed goals

- Goal frame categories

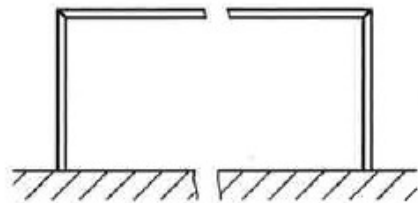

a) Category A

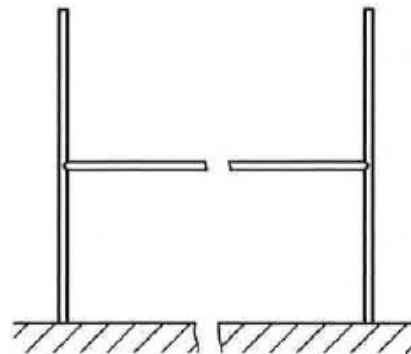

b) Category B

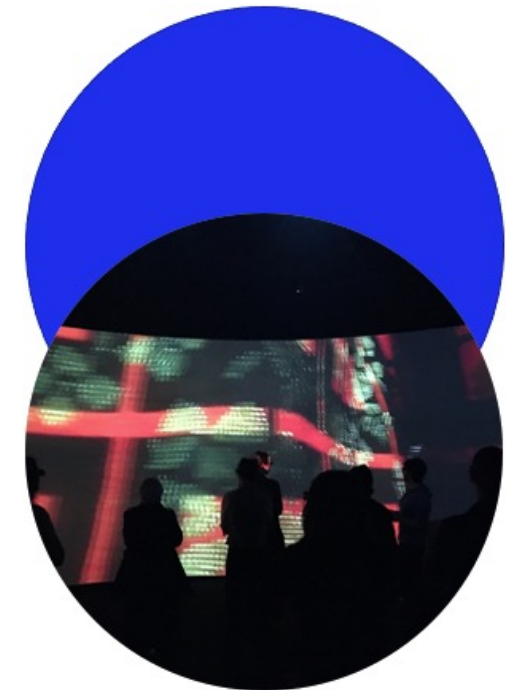

- This is the easy part
- The complexity lies in choosing the sub-categories which are quite specific to the dimensions and weight of the goal

AS EN 16579:2020 Portable and permanent socketed goals

Category	Type	Class	Total weight m (including back bar, net, net fixing, and any permanently attached anchoring or stabilizing system) kg	Size ranges		
				Width w (internal) m	Height to crossbar h_1 (internal) m	Overall height of uprights h_2 m
A1	1	Socketed ^a	$m > 10,0$	$0,70 \leq w \leq 1,80$	$0,50 \leq h_1 \leq 1,20$	—
	2	Portable	$10,0 < m \leq 18,0$			
	3	Portable	$18,0 < m \leq 42,0$			
	4	Portable	$m > 42,0$			
A2	1	Socketed ^a	$m > 10,0$	$1,80 \leq w \leq 4,88$	$0,80 \leq h_1 \leq 1,99$	—
	2	Portable	$10,0 < m \leq 22,0$			
	3	Portable	$22,0 < m \leq 42,0$			
	4	Portable	$m > 42,0$			
A3	1	Socketed ^a	$m > 10,0$	$3,00 \leq w \leq 6,40$	$2,00 \leq h_1 \leq 2,44$	—
	2	Portable	$10,0 < m \leq 18,0$			
	3	Portable	$18,0 < m \leq 42,0$			
	4b	Portable	$m > 42,0$			
A4 ^c	1	Socketed ^a	$m > 10,0$	$6,40 < w \leq 7,32$	$2,00 \leq h_1 \leq 2,44$	—
	2	Portable	$18,0 < m \leq 42,0$	$6,40 < w \leq 7,32$	$2,00 \leq h_1 \leq 2,44$	—

^a As socketed goals can be left on a playing field they need to satisfy the highest stability and strength requirements for their Class irrespective of their weight, to minimize the risk of injury in case of misuse.

^b Goals with a weight > 42,0 kg and a size of 5,00 m × 2,00 m are covered in EN 748.

^c Goals with a weight > 42,0 kg and a size of 7,32 m × 2,44 m are covered in EN 748.

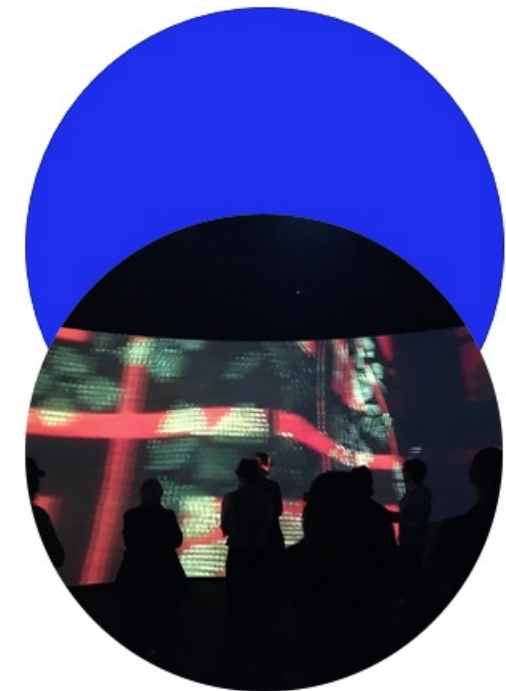

AS EN 16579:2020 Portable and permanent socketed goals

Category	Type	Class	Total weight m (including net, net fixing and any permanently attached anchoring or stabilizing system) kg	Size ranges		
				Width w (internal) m	Height to crossbar h_1 (Gaelic) (to top of the crossbar (Rugby)) m	Overall height of uprights h_2 m
B1	1	Socketed ^a	—	$2,50 \leq w < 3,00$	$1,50 \leq h_1 < 1,85$	$4,50 \pm 0,05$
	2	Portable	$10,0 < m \leq 20,0$			
	3	Portable	$20,0 < m \leq 42,0$			
	4	Portable	$m > 42,0$			
B2	1	Socketed ^a	—	$3,00 \leq w < 4,60$	$1,85 \leq h_1 < 2,20$	$4,50 \pm 0,05$
	2	Portable	$10,0 < m \leq 20,0$			
	3	Portable	$20,0 < m \leq 42,0$			
	4	Portable	$m > 42,0$			
B3	1	Socketed ^a	—	$4,60 \leq w < 6,50$	$2,20 \leq h_1 \leq 2,50$	$8,50 \pm 0,05$
	2	Portable	$10,0 < m \leq 20,0$			
	3	Portable	$20,0 < m \leq 42,0$			
	4	Portable	$m > 42,0$			
B4	1	Socketed ^a	—	$4,55 \leq w < 4,65$	$2,20 \leq h_1 \leq 2,50$	$6,00 \leq h_2 \leq 10,00$
	2	Portable	$10,0 < m \leq 20,0$			
	3	Portable	$20,0 < m \leq 42,0$			
	4	Portable	$m > 42,0$			
B5	1	Socketed ^a	—	$6,45 \leq w < 6,55$	$2,39 \leq h_1 \leq 2,49$	$11,00 \pm 0,05$
B6	1	Socketed ^b	—	$5,50 \leq w < 6,50$	$2,44 \leq h_1 \leq 3,10$	$3,40 \leq h_2 \leq 16,00^b$

^a As socketed goals can be left on a playing field they need to satisfy the highest stability and strength requirements for their Class irrespective of their weight, to minimize the risk of injury in case of misuse.

^b The laws of the game of Rugby Union do not specify any maximum value (see [1]). The maximum value is given as guidance.

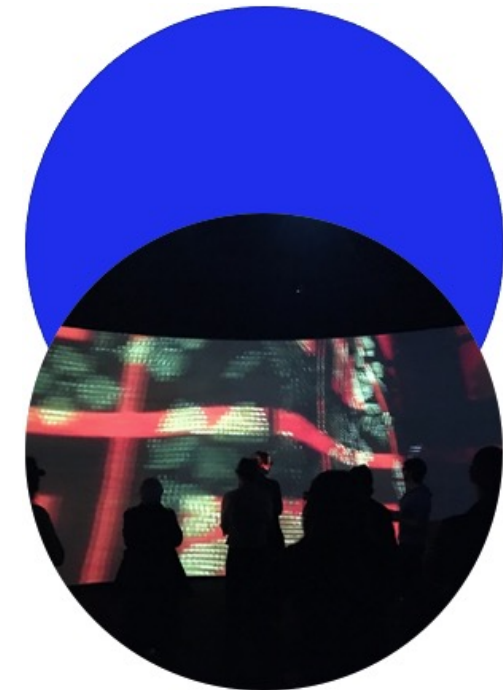

AS EN 16579:2020 Portable and permanent socketed goals

Category	Type	Strength Testing Vertical Loading N	Stability Testing Horizontal Loading N
A1	1	800 ± 50	700 ± 50
	2	300 ± 15	300 ± 15
	3	800 ± 30	700 ± 50
	4	1 800 ± 50	1 100 ± 50
A2	1	800 ± 50	700 ± 50
	2	300 ± 15	300 ± 15
	3	800 ± 30	700 ± 50
	4	1 800 ± 50	1 100 ± 50
A3	1	1 800 ± 50	1 100 ± 50
	2	300 ± 15	300 ± 15
	3	1 000 ± 50	700 ± 50
	4	1 800 ± 50	1 100 ± 50
A4	1	1 800 ± 50	1 100 ± 50
	2	1 000 ± 50	700 ± 50
B1	1	700 ± 50	700 ± 50
	2	300 ± 15	300 ± 15
	3	600 ± 30	700 ± 50
	4	1 500 ± 50	1 100 ± 50
B2	1	700 ± 50	700 ± 50
	2	300 ± 15	300 ± 15
	3	600 ± 30	700 ± 50
	4	1 500 ± 50	1 100 ± 50
B3	1	2 000 ± 50	1 250 ± 50
	2	300 ± 15	300 ± 15
	3	600 ± 30	700 ± 50
	4	2 000 ± 50	1 250 ± 50
B4	1	1 500 ± 50	1 100 ± 50
	2	300 ± 15	300 ± 15
	3	600 ± 30	700 ± 50
	4	1 500 ± 50	1 100 ± 50
B5	1	2 000 ± 50	1 100 ± 50
B6	1	2 000 ± 50 ^a	1 100 ± 50 ^a

^a The maximum value of 16,0 m as given in Table 2 is the basis for this loading.

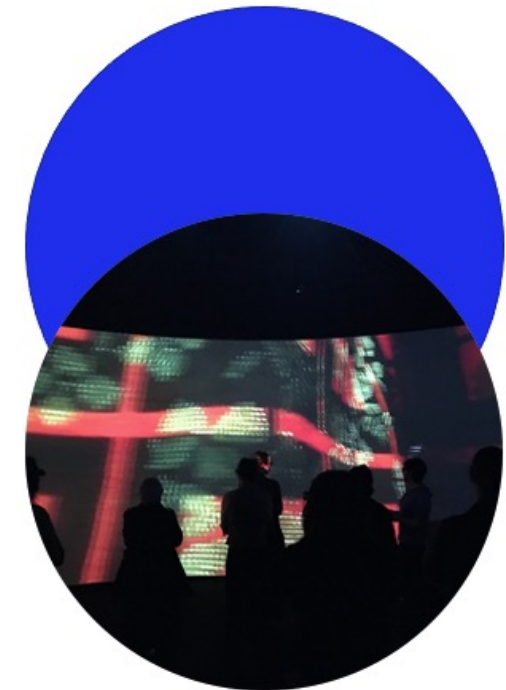

AS EN 14974:2021 Skateparks

General requirements

- This Standard applies to skateparks for public use intended for skateboard usage
- It does NOT apply to other roller sports equipment and BMX bikes
- Skateparks shall be physically separated from playgrounds, sports grounds etc by appropriate distance using structural or spatial measures



AS EN 14974:2021 Skateparks

Example of a mini ramp

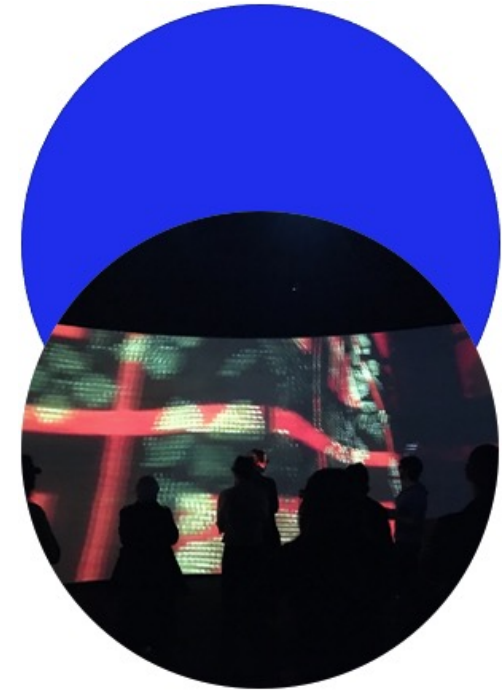
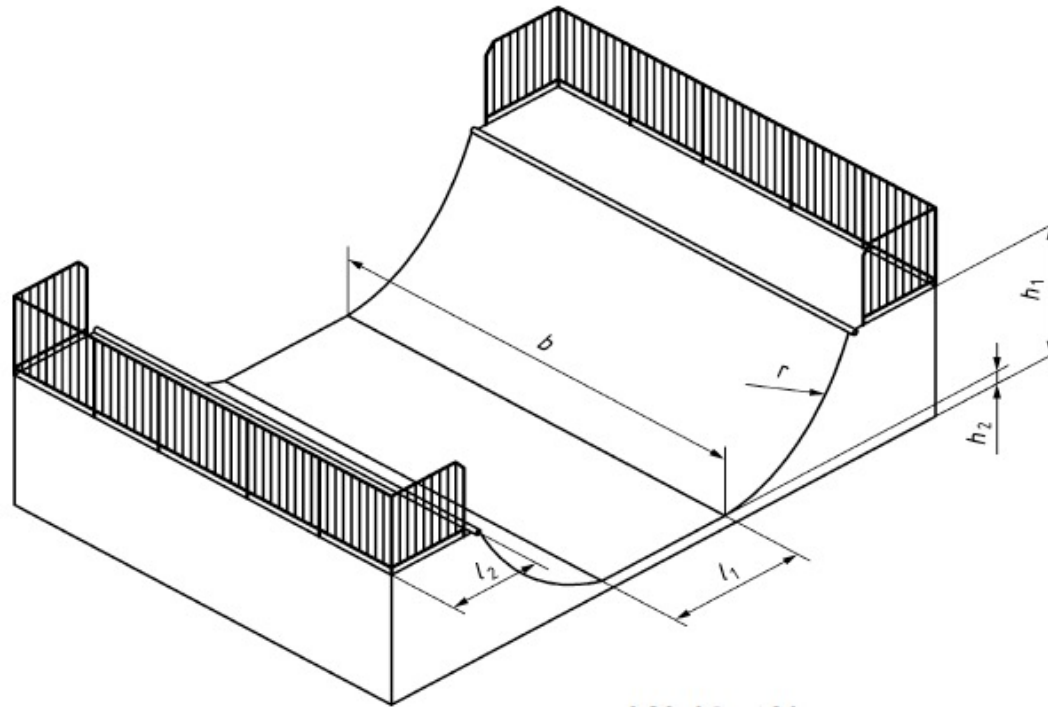

AS EN 14974:2021 Skateparks

Example of a Vert ramp (half-pipe)

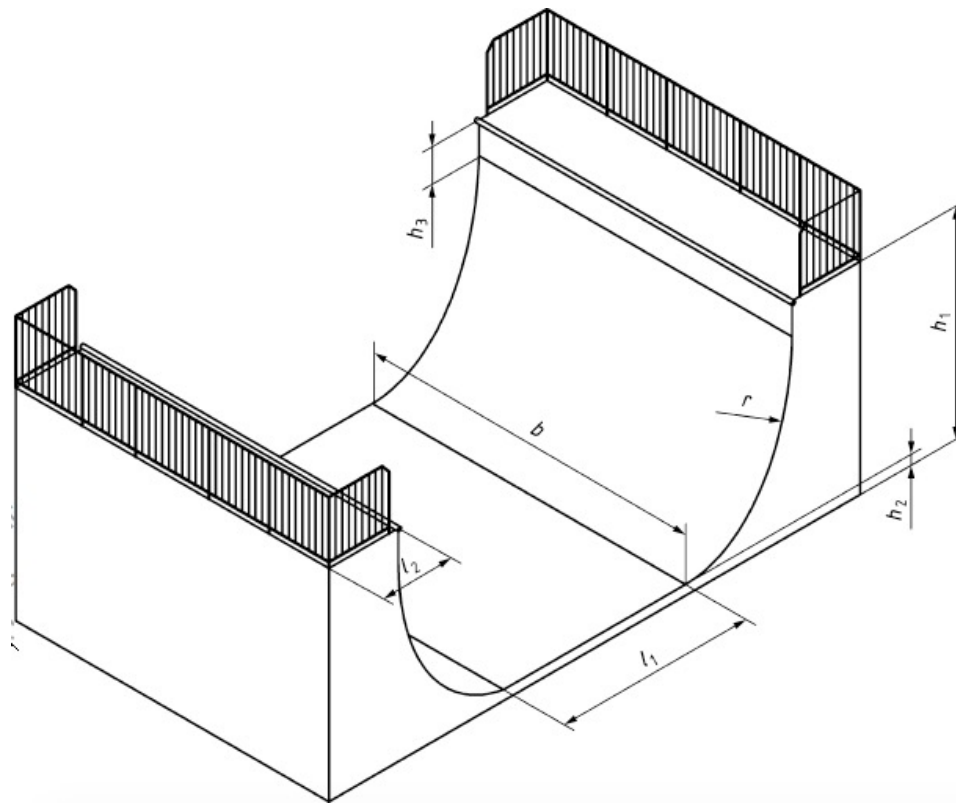

AS EN 14974:2021 Skateparks

Dimensions for mini ramps and Vert ramp (half-pipe)

Description	h_1 mm	b mm	r mm	h_3 mm	h_2 mm	l_1 mm	l_2 mm
Mini ramp	$\leq 1\ 250$	$\geq 2\ 400$	$\geq h_1$	no vert allowed ^a	≤ 600	$\geq r/2$	≥ 1200
	$> 1\ 250$ to $1\ 500$	$\geq 3\ 600$					
	$> 1\ 500$ to $2\ 000$	$\geq 4\ 800$					
	$\geq 2\ 000$ to $2\ 500$	$\geq 6\ 000$					
Vert ramp (half-pipe)	$\geq 1\ 500$ to $2\ 500$	$\geq 4\ 800$	$\geq 1\ 400$ to $2\ 400$	≤ 300	≤ 600	$\geq r/2$	≥ 1200
	$\geq 2\ 500$ to $4\ 200$	$\geq 6\ 000$	$\geq 2\ 400$ to $3\ 600$	≤ 600			
	$> 4\ 200$ to $5\ 000$	$\geq 7\ 200$	$\leq 4\ 500$	$\leq 1\ 000$			

^a Vert is allowed for extensions.



AS 16630:2021 Permanently installed outdoor fitness equipment

- AS 16630:2021 is a modified adoption of EN 16630:2015
- It specifies the general safety requirements for the manufacture, installation, inspection and maintenance of permanently installed and freely accessible outdoor fitness equipment
- The ZZ Appendix for Australia includes amendments for timber, ultraviolet radiation exposure protection for no less than 5 years after installation, shade and sun protection and a clause that allows existing Australian products to comply with the new technical requirements while not being trade restrictive ie reverse WTO TBT (technical barrier to trade)



AS 16630:2021 Permanently installed outdoor fitness equipment

cl 4.3.4 delete the following:

~~Additionally, the tread surface shall provide at least a three-sided safeguard (at the front, left and right) that is a minimum of 10 mm high and extend over a length of 75 % of the side surface. This requirement is not applicable to rotary discs with a diameter of at least 320 mm.~~

and replace with:

Additionally, the tread surface shall provide at least a three-sided safeguard. One side of the safeguard on the front, shall be a minimum of 10 mm high and extend over a length of 75% of the side surface. This requirement is not applicable to rotary discs with a diameter of at least 320 mm.

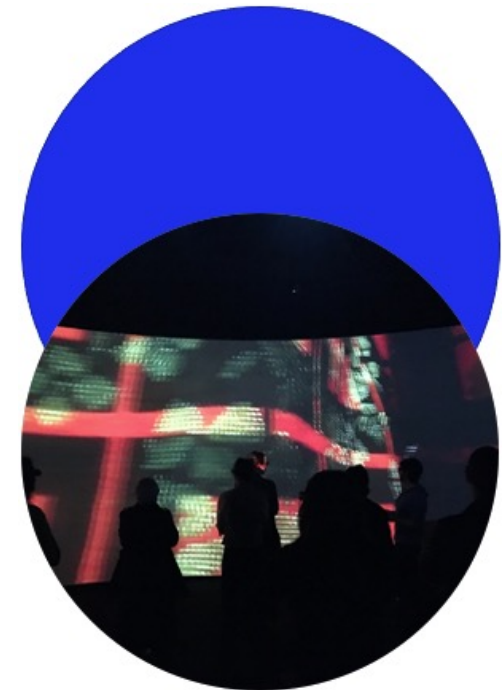

AS 16630:2021 Permanently installed outdoor fitness equipment

- The Standard is similar to the Playground equipment standard
- The major difference is the mass of the user
 - For a single user the mass is increased from 69.5 kg to 99 kg
 - For two users the mass is increased from 130 kg to 185 kg
 - For three users the mass is increased from 189 kg to 270 kg
- The dynamic factor is the same for both standards

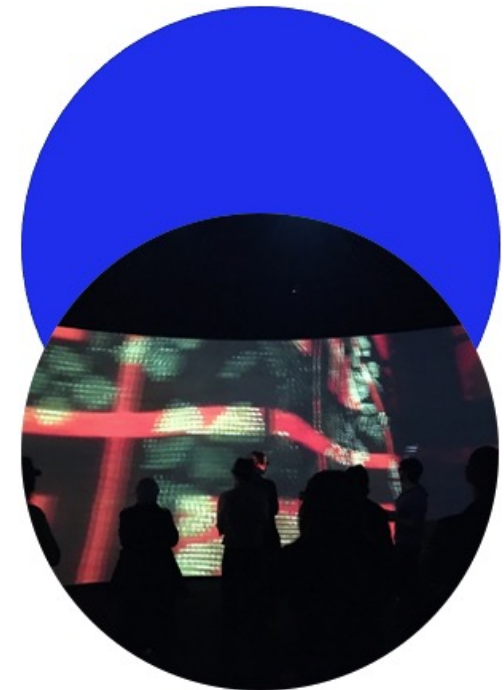

AS 16630:2021 Permanently installed outdoor fitness equipment

The other major difference is impact area and critical fall height

AS 16630

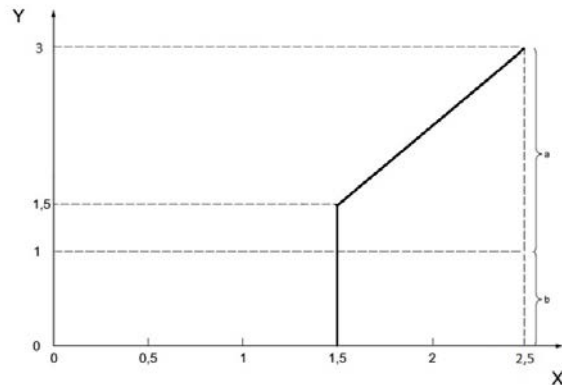

Key
 if $Y \leq 1.5$, then $X = 1.5$ (in metres)
 if $Y > 1.5$, then $X = 2/3 \cdot Y + 0.5$ (in metres)
 a impact attenuation surface with requirements
 b surface with no requirements, unless there is a forced movement
 X minimum dimensions of the area of movement
 Y free height of fall

AS 4685

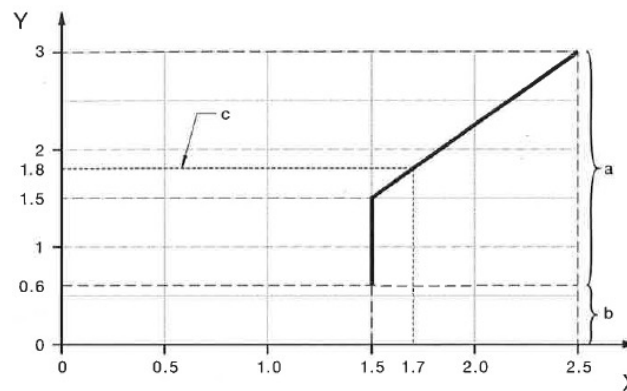

If $0 \leq y < 0.6$ then $x \leq 1.5$ (in metres)
 If $0.6 \leq y \leq 1.5$ then $x = 1.5$ (in metres)
 If $y > 1.5$, then $x = 2/3 y + 0.5$
 If $y = 1.8$ then $x = 1.7$

LEGEND
 y = free height of fall
 x = minimum dimension of impact area
 a = impact attenuating surface with requirements (4.2.8.5.2)
 b = surface provided in accordance with 4.2.8.5.3
 c = maximum free height of fall and impact area for SECS

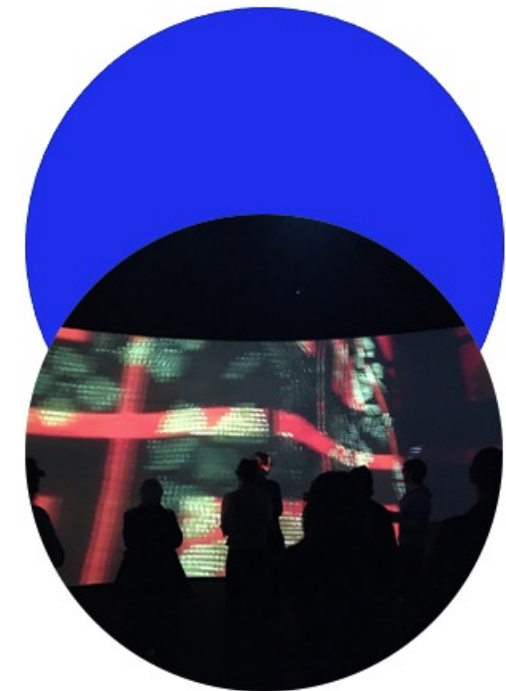

The critical fall height for both standards is determined by a performance test in accordance with AS 4422 (not from the table within the CEN document)

AS TR CEN 17519:2021 Synthetic turf facilities

- This is a Technical Report (not a Standard) that provides guidance on how to minimize infill dispersion
- What is infill?
- Infill is a particulate material used within the synthetic turf surface to provide support to the pile and aid in the provision of the required performance characteristics of the surface
- Why is this standard required?
- There has been an increasing public concern about microplastics being released into the environment
- This standard aims to reduce the quantities released into the environment



AS TR CEN 17519:2021 Synthetic turf facilities

Infill migration routes include:

- Being carried by the player in their footwear
- Being carried by maintenance equipment
- Inappropriate maintenance procedures
- Inappropriate installation procedures
- Poor storage of spare material
- Water run-off from the field
- Wind dispersion

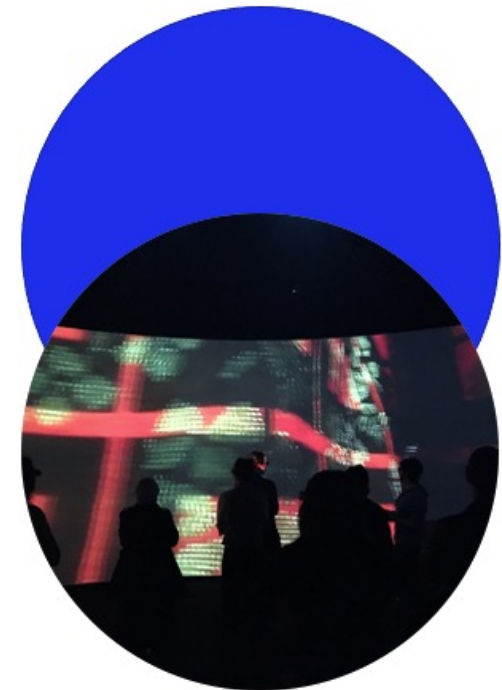

Thank
you

