



## Evaluation of alternative power-to-chemical pathways for renewable energy exports

Muhammad Aadil Rasool<sup>a</sup>, Kaveh Khalilpour<sup>a,\*</sup>, Ahmad Rafiee<sup>b</sup>, Iftekhhar Karimi<sup>c</sup>, Reinhard Madlener<sup>d,e</sup>

<sup>a</sup> Faculty of Engineering and IT, University of Technology Sydney, Australia

<sup>b</sup> Dana Cluster Pty Ltd, Sydney, Australia

<sup>c</sup> Department of Chemical & Biomolecular Engineering, National University of Singapore, Singapore

<sup>d</sup> Institute for Future Energy Consumer Needs and Behavior, School of Business and Economics / E.ON Energy Research Center, RWTH Aachen University, Aachen, Germany

<sup>e</sup> Department for Industrial Economics and Technology Management, Norwegian University of Science and Technology (NTNU), Trondheim, Norway

### ARTICLE INFO

#### Keywords:

Hydrogen economy  
Renewable hydrogen vector  
Renewable energy utilisation  
Renewable energy supply chain  
Decision analysis cycle  
Expected levelised cost of hydrogen

### ABSTRACT

Over the last five decades, there have been several phases of interest in the so-called hydrogen economy, stemming from the need for either energy security enhancement or climate change mitigation. None of these phases has been successful in terms of a major market development, mainly due to the lack of cost competitiveness and partially due to technology readiness challenges. Nevertheless, a new phase has begun very recently, which despite holding original objectives has the new motivation to be fully green, i.e. based on renewable energy. This new movement has already initiated bipartisan cooperation of some energy importing countries and those with abundant renewable energy resources and supporting infrastructure. One key challenge in this context is the diversity of pathways for the (national and international) export of non-electricity renewable energy. This poses another challenge, that is the need for an agnostic tool for comparing various supply chain pathways fairly while considering various techno-economic factors such as renewable energy sources, hydrogen production and conversion technologies, transport, and destination markets, along with all associated uncertainties.

This paper addresses the above challenge by introducing a probabilistic decision analysis cycle methodology for evaluating various renewable energy supply chain pathways based on the hydrogen vector. The decision support tool is generic and can accommodate any kind of renewable chemical and fuel supply chain option. As a case study, we have investigated eight supply chain options composed of two electrolyzers (alkaline and membrane) and four carrier options (compressed hydrogen, liquefied hydrogen, methanol, and ammonia) for export from Australian ports to three destinations in Singapore, Japan, and Germany. The results clearly show the complexity of decision making induced by multiple factors, and that the preferred supply chain combination (electrolyser technology, green energy carrier) in terms of least cost strongly depends on whether the expected levelized cost of hydrogen (ELCOH) or the expected levelized cost of energy (ELCOE) is used as a decision criterion. For instance, with ELCOH for the case study, under the given input parameters, the Ammonia combination with alkaline electrolyzers (AE-NH<sub>3</sub>) becomes the least-cost supply chain option for Singapore, Japan, and Germany with values of 8.60, 8.78 and 9.63 \$/kgH<sub>2</sub>, respectively. This leaves liquid hydrogen (with alkaline electrolyzers) as the second-best supply chain route, with ELCOH values of 9.05, 9.39 and 10.70 \$/kgH<sub>2</sub>, respectively. However, with ELCOE, methanol (with alkaline electrolyzers) becomes the preferred supply chain path for all destinations, and liquid hydrogen (with alkaline electrolyzers) keeps its place as the second-best alternative.

\* Corresponding author.

E-mail address: [kaveh.khalilpour@uts.edu.au](mailto:kaveh.khalilpour@uts.edu.au) (K. Khalilpour).

<https://doi.org/10.1016/j.enconman.2023.117010>

Received 6 January 2023; Received in revised form 25 March 2023; Accepted 3 April 2023

Available online 9 May 2023

0196-8904/© 2023 The Authors. Published by Elsevier Ltd. This is an open access article under the CC BY-NC-ND license (<http://creativecommons.org/licenses/by-nc-nd/4.0/>).

Nomenclature	
$C$	scenario for CAPEX ( $1 \leq c \leq C$ )
$CF_i$	annual capacity factor of plant $i$
$CR_{jr}$	ship charter rate (cost per day)
$CR_{rn}$	charter rate for scenario $r$ ( $1 \leq r \leq R$ ) in year $n$
$CX_{ic}$	CAPEX of production technology $i$ and scenario $c$
$CX_{jc}$	CAPEX of carrier $j$ and scenario $c$
$d$	discount rate
$D$	transport distance (laden + ballast)
$DC$	design capacity of the process in terms of unit weight of product per time interval $\Delta t$
$e$	price scenario for electricity ( $1 \leq e \leq E$ )
$EC$	electricity capacity
$ELCOE_{ij}$	levelised cost of energy (e.g., \$/GJ)
$ELCOH$	expected levelised cost of hydrogen
$EP_{en}$	electricity price for scenario $e$ ( $1 \leq e \leq E$ ) in year $n$ ( $1 \leq n \leq N$ )
$f$	scenario for conversion efficiency ( $1 \leq f \leq F$ )
$FC_j$	fuel consumption rate (weight per time) for carrier option $j$
$FCK1$	fuel cost per unit weight under fuel price scenario $k$ in the first year ( $n = 1$ )
$FCF$	fixed charge factor for levelisation of total CAPEX
$FP_{kn}$	fuel price for scenario $k$ ( $1 \leq k \leq K$ ) in year $n$
$FR_j$	consumption rate of the fuel for the tanker of carrier $j$
$G$	number of scenarios for greenhouse gas (GHG) tax or credit
$GP_{gn}$	GHG cost/tax/credit for scenario $g$ ( $1 \leq g \leq G$ ) in year $n$
$HC$	input hydrogen capacity per time interval $\Delta t$
$i$	production technology (Alkaline Electrolyser: $i = 1$ and Polymer Electrolyte Membrane: $i = 2$ )
$I_j$	insurance and other costs
$j$	carrier option (CH <sub>2</sub> : $j = 1$ , LH <sub>2</sub> : $j = 2$ , NH <sub>3</sub> : $j = 3$ , and MeOH: $j = 4$ )
$k$	price scenarios for bunker fuel ( $1 \leq k \leq K$ )
$LCOC$	levelised cost of conversion
$LCOP$	levelised cost of production
$LCOS$	levelised cost of storage
$LCOT$	levelised cost of transport
$LHV_j$	lower heating value of the carrier $j$
$LR_j$	filling rate (loading and offloading)
$ns$	stack life
$OX$	OPEX of the plant during year $n = 1$
$PC_j$	port costs (per day)
$Pr$	probability value
$q$	quantity of stacks used
$R$	scenario for carriers ( $1 \leq r \leq R$ )
$SC_{ic}$	stack cost for technology $i$ and CAPEX scenario $c$
$TPY$	number of time intervals ( $\Delta t$ ) within a year
$VC_j$	vessel capacity (weight) for product
$w_j$	weight ratio of hydrogen to product (value of one for CH <sub>2</sub> and LH <sub>2</sub> )
<i>Greek letters</i>	
$\alpha_j$	rate of carrier loss during transport due to various reasons including boil-off
$\gamma_j$	complexity factor for each carrier tanker
$\epsilon_{jf}$	compressor efficiency
$\eta_{jf}$	conversion efficiency of electricity (e.g., kWh) to hydrogen (e.g., kgH <sub>2</sub> ) for technology $i$ and scenario $f$
$\theta_j$	amount of CO <sub>2</sub> per weight of H <sub>2</sub> consumed (applicable here only to MeOH)
$\zeta_{jf}$	electricity consumption (kWh/kgH <sub>2</sub> consumed) for carrier $j$
$v_j$	vessel speed
<i>List of abbreviations</i>	
AE	alkaline electrolysers
ASG	Asia super grid
CAPEX	capital expenditure
CCS	carbon capture and storage
CH <sub>2</sub>	compressed hydrogen
DA	decision analysis
DAC	decision analysis cycle
DES	Delivered Ex Ship
DME	di-methyl-ether
EV	electric vehicles
GHG	greenhouse gas
HVDC	high voltage direct current
IRENA	International Renewable Energy Agency
LH <sub>2</sub>	liquefied hydrogen
LNG	liquefied natural gas
LOHC	liquid organic hydrogen carriers
NM	nautical miles
NPV	net present value
OPEX	operation expenditure
PEM	polymer electrolyte membrane electrolyser
PV	solar photovoltaics
SOEC	solid oxide electrolyser cell
Syngas	synthesis gas
ULCC	ultra large crude carriers
VLCC	very large crude carriers
WGS	water-gas shift

## 1. Introduction

Needless to highlight the several benefits of renewable energies, particularly their widespread distribution and the least environmental impact. Nevertheless, until recently, except for biomass and hydro, the other types of renewable energies – particularly wind and solar photovoltaics (PV) – were not competitive with fossil fuels [1]. The price revolution of wind and PV over the recent decade has shaken the traditional view of renewables as a “future energy” source. Today, in several jurisdictions, renewables have reached market parity with fossil fuels [2] and have altered the approach of policy-makers and investors toward renewables from a means for demand security to a commodity for export [3,4]. We are presently just at the emergence of the new research field and the new industry of “global renewable energy supply chain” [5].

The factors mentioned above highlight the need for alternative

options for diversification of renewable energy exports and risk minimisation considering techno-economic and political uncertainties [6]. The enquiry of an alternative pathway for renewable energy exports leads to the option of using renewable electricity to electrolyse water into hydrogen and oxygen [7]. This is the least sophisticated approach, as the production system is mainly composed of water and electrolyser. Historically, water electrolysis has not been a favourite approach due to high energy demand (approximately 1.5 units of electrical energy per unit of generated hydrogen energy). But, with access to cheap renewable electricity, this path can be a potential option. Once hydrogen is generated, the remaining steps of the renewable energy supply chain become almost identical to that of natural gas, as both hydrogen and natural gas are gases at standard pressure and temperature. Both gases suffer from low energy density and specific energy and similarly various pathways have been introduced for changing the form of these gases (physically or chemically) for long-distance exports [8]. Compression

and/or liquefaction are two immediate physical options, followed by chemical conversion. Then a legitimate question arises on how to identify the best production pathway for hydrogen exports across different regions [9]. This paper addresses this problem by introducing a decision analysis cycle for evaluating various pathways for renewable energy supply chains based on the hydrogen vector.

### 1.1. Hydrogen supply chain

Hydrogen is the main component of the universe and the source of solar energy [10]. However, it is not accessible as an element in the biosphere and hence it took a longer time to be hypothesised (Robert Boyle, 1671) [11], identified (Henry Cavendish, 1766) [12], and named as hydrogen (Antoine Lavoisier, 1783) [13]. Access to hydrogen requires a chemical reaction (e.g., water or hydrocarbons), and the leading commercial approaches are through gasification and reforming of fossil fuels to generate synthesis gas (syngas), i.e., a mixture of  $H_2$  and  $CO$ , followed by a downstream water–gas shift (WGS) reactor ( $CO + H_2O \rightleftharpoons CO_2 + H_2$ ) and finally a  $CO_2$  removal unit. Fig. 1 (a) represents the main current hydrogen production pathways. Although gasification of biomass, coal, and oil are possible pathways of syngas generation, when available, steam reforming of natural gas has been the favoured industrial route due to the highest  $H_2/CO$  ratio of its syngas.

Due to this difficulty of obtaining elemental hydrogen, until the recent decades, it had not been seriously discussed as an “energy source”, though its energy content per unit of weight is the highest among the common fuels (e.g., about 3x of that for gasoline [14]). Rather, it has been historically used as a “process gas” in manufacturing, particularly in oil refineries for crude oil upgrading (e.g., hydrotreating and hydrocracking [15,16]), and later in ammonia production [17,18] (see Fig. 1 b).

There have been, however, a few phases of interest in hydrogen as an energy source which is often referred to as the “hydrogen economy”. One was during the world oil crisis of the 1970s when interests spiked in hydrogen as an alternative energy source, especially for the transport industry [20]. The idea was that, for instance, hydrogen produced from coal could be used in fuel cell electric vehicles (EVs) to mitigate the dependence on international oil/petrol imports. Despite some technological developments, there was not a major success due to the large price gap with the market reality of the time. The next phase of interest was after the Kyoto Protocol when the projection of the carbon penalty

remobilised the interests in the hydrogen economy. Hydrogen was nominated as a clean energy alternative at least for the transport sector. However, still, the market was not fully ready. The main reason for these two mentioned phases falling in the chasm is the high cost of electricity which has accounted for more than 2/3 of the cost of the produced hydrogen [21]. Furthermore, the electricity sourced from fossil fuels had embodied  $CO_2$  emissions with the challenge of employing carbon capture and storage (CCS) technologies and significant extra cost implications in the form of a carbon penalty/tax [22,23]. The new phase has, however, begun recently with the revolutions in the wind and solar energy prices which have overshoot the equivalence price of fossil fuels in some countries [24]. These, along with the projection of a continuous price decline and the emergence of surplus renewable energies, as well as the concerns over climate change and energy security, are the main drivers for the increasing interest in the hydrogen economy, particularly, the renewables-derived water splitting.

Today, on the one hand, we have energy-importing countries such as Japan, Korea, and Singapore that are exploring alternative energy sources such as hydrogen to decarbonise their energy supply chains. On the other hand, some countries with high renewable energy resource potentials have taken steps even beyond self-security and are considering the possibility of renewable energy exports [25]. For such countries, there is an enormous potential to exploit these resources through various energy harvesting technologies such as wind farms, solar PV, and solar-thermal systems. When the market is saturated for electricity, the surplus can be converted to hydrogen as an intermediary or ultimate form of energy. The challenging question, however, is the choice of the techno-economically and socio-politically most feasible renewable energy carriers.

Depending on the quantity and distance, hydrogen transmission can be carried out by several methods from production locations to retailers. Small quantities of hydrogen can be delivered as compressed hydrogen ( $CH_2$ ) via gaseous tube trailers for short distances [26]. Hydrogen compression to 350 bar and 700 bar improves its density to  $23.32 \text{ kg/m}^3$  and  $39.22 \text{ kg/m}^3$  [27], respectively. At present,  $CH_2$  storage is mainly used in fuel cell-powered vehicles and refuelling stations. Large-scale hydrogen storage options for future considerations include underground storage (favourably in salt formations), storage in buried steel pipes, and aboveground spherical or cylindrical steel tanks [28–31]. Liquid tankers are the preferred option for medium hydrogen amounts and longer distances. Typical tanker capacity varies from 400 to 4000 kg

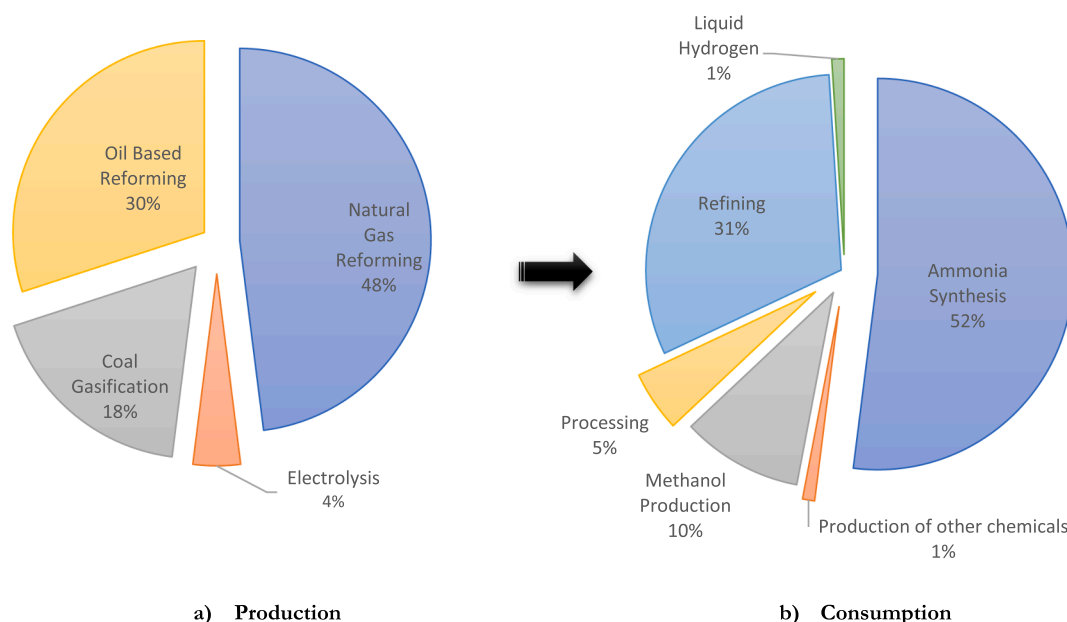

Fig. 1. Breakdown of global hydrogen production and use routes [19].

of liquefied hydrogen (LH<sub>2</sub>). Kawasaki Heavy Industry aims at building 200-tonne liquefied hydrogen carriers [32]. Storing liquefied hydrogen is also a technically feasible option for small-scale applications.

Larger amounts of hydrogen can be delivered via pipeline grids over long distances. Such networks are already existing, though only at a very small scale. For instance, in 2016, the global hydrogen transport pipeline network was around 4500 km (~36% in the EU region and ~58% in the US) [33]. Another possibility that has been receiving increasing attention in recent times is the scenario of injecting hydrogen into natural gas grids either to supply a new energy mix (natural gas and hydrogen) or to separate the hydrogen in the destination and deliver pure gas to the final users' markets [33–35]. However, exporting large quantities of renewable energy, through the hydrogen vector, over long distances (especially cross-ocean) is a complex multi-criteria decision-making problem. For instance, CH<sub>2</sub> might be the simplest technical solution due to ease of storage and retrieval at ambient temperature. Nonetheless, even at 700 bar, CH<sub>2</sub> suffers from a low volume intensity challenge (39.22 kg/m<sup>3</sup> [27]) which increases the transport costs for long distances. In terms of volume intensity, LH<sub>2</sub> is in a better situation with 70.85 kg/m<sup>3</sup> at the atmospheric pressure. However, the exergy efficiency of liquefaction to –252.87 °C is low and, similar to the LNG, the cost of cryogenic tankers is high. Furthermore, there are inevitable boil-off losses during LH<sub>2</sub> storage and transport. Hydrogen storage in solid materials (physisorption or chemisorption) is a safe method [36,37] with the key challenge being the energy storage capacity per weight and the need for recycling of the carrier material. Alternative hydrogen carriers are possible by the further conversion of hydrogen to other products, particularly chemical species such as synthetic methane [38–40], ammonia [41–43], methanol [44–46], di-methyl-ether (DME) [47], and methylcyclohexane [3,48]. Some of these chemicals are directly used (e.g., ammonia, methanol, and DME), or can be reverted back to hydrogen at the demand market for direct use (e.g., methanol [49], ammonia [50], and methylcyclohexane [51]). Another classification of these chemicals is based on carrier recycle. For instance, methanol, ammonia, and DME are one-way transport chemicals. However, the so-called liquid organic hydrogen carriers (LOHC) involve cyclic processes and require the recycling of the carrier chemicals back to the production port. For instance, the toluene-methylcyclohexane cycle (CH<sub>3</sub>C<sub>6</sub>H<sub>5</sub> + 3 H<sub>2</sub> ↔ CH<sub>3</sub>C<sub>6</sub>H<sub>11</sub>) is based on hydrogenation of toluene to methylcyclohexane and dehydrogenation of MCH upon delivery.

In this regard, a key question is which option offers the security of investment over the project's lifecycle against market fluctuations, trade embargos, political changes and/or technological advances [52]. In recent years, there has been growing research interest to address this question. The IEA's report on the "Future of Hydrogen" [3] has evaluated the hydrogen energy chain qualitatively and quantitatively and analysed several potential hydrogen supply chain paths. To better understand the concept of production and transport of hydrogen as an energy carrier, we studied similar existing energy transport supply chains [53]. The Australian National Hydrogen Roadmap [54] considers in detail the different ways and costs associated with hydrogen exports. It discusses hydrogen production from renewable and non-renewable options. This document has been prepared in an Australian context and provides a cost analysis of each process separately, and not of the energy supply chain as a whole [55].

Considering the different hydrogen production technologies, Marcello et al. [56] shares a comprehensive review on Polymer Electrolyte Membrane Electrolyser (PEM) electrolysis and describes the technological edge over alkaline electrolysers (AE). It provides higher pressure outputs of hydrogen, better response to variation in plant production output and higher stack life. As of now, it is more expensive than AE but if costs are brought down, PEM may be a game-changer. The International Renewable Energy Agency (IRENA) [4] has also conducted a detailed cost analysis of alternate electrolyser technologies. Matzen et al. [57] have compared the transport of hydrogen in the form of methanol and ammonia through electrolysis with electricity input from

wind power plants. The study concluded that production from methanol is cheaper than ammonia, further to its ease of transport. Additionally, COAG [58] has prepared a qualitative analysis of the hydrogen export potential from Australia and has also devised a policy for future investments in this industry segment of the renewable hydrogen supply chain.

The missing element in the literature is the introduction of a clear mathematical framework with consideration of uncertainty. In the context of natural gas, Khalilpour and Karimi [59] introduced a systematic method based on a decision analysis cycle to identify the most feasible natural gas utilisation pathways in the presence of uncertainty. They provided a comparison of different forms of transport of stranded natural gas with a decision criterion for expected net present value (NPV), keeping production capacities, market allocations and delivery vessels in context. This study builds on that methodology and aims at introducing a similar framework to investigate renewable energy utilisation options [60]. Though the methodology is generic, for the purpose of demonstration, we have identified four alternative carrier options for the export of renewable energy, including compressed hydrogen (CH<sub>2</sub>), liquefied hydrogen (LH<sub>2</sub>), ammonia (NH<sub>3</sub>) and methanol (MeOH) [61]. Fig. 2 illustrates this problem with Australia as an exemplary exporter.

In the remainder of this paper, we introduce a methodology for the selection of the best option for export supply chains, comparing their cost of production, transmission, storage, conversion, and transport for significant offshore distances [62].

## 2. Problem statement

Consider a region with high-quality renewable energy resources and abundant land [63]. With the continuous growth in the renewable energy investment in the region and considering a prospect for local electricity market saturation, an investment company assesses other market opportunities for renewable energy utilisation/monetisation. As one option, the company, located in coastal areas, investigates the potential distant markets which are only accessible by sea. Cross-ocean high-voltage direct current (HVDC) lines have already been assessed and the current key investigation is on shipping the renewable energy in other forms than electricity, viz. through the hydrogen vector. Based on the renewable energy resources, and the anticipated market conditions, the company assesses the development of the H<sub>2</sub> vector supply chain based on the baseload input Electricity Capacity *EC* (e.g., in MW). There are three key types of electrolysers, including Alkaline Electrolyser (AE), Polymer Electrolyte Membrane Electrolyser (PEM), and Solid Oxide Electrolyser Cell (SOEC) [64]. However, the SOEC is not yet a mature technology [65], but there have been numerous installations and studies based on AE and PEM technologies in different locations and under various scenarios. As such, the company aims to analyse these two electrolyser technologies based on their techno-economic features. For the carrier option, the company assesses compressed hydrogen, liquefied hydrogen, ammonia and methanol.

Putting into a formulation, the company has  $I = 2$  H<sub>2</sub> production options and  $J = 4$  carrier options. The two production options include AE ( $i = 1$ ) and PEM ( $i = 2$ ), and the carrier options are CH<sub>2</sub> ( $j = 1$ ), LH<sub>2</sub> ( $j = 2$ ), NH<sub>3</sub> ( $j = 3$ ), and MeOH ( $j = 4$ ). This makes  $O = 2 \times 4 = 8$  supply chain options (combined production  $i$  and carrier  $j$ ) for investigation. Fig. 3 visualises these eight supply chain routes. All value chains include electrolyser, H<sub>2</sub> storage, conversion unit (compression for CH<sub>2</sub>, cryogenic liquefaction for LH<sub>2</sub>, and process plants for NH<sub>3</sub> and MeOH), carrier storage, and transport.

The H<sub>2</sub> production units are assumed to be near the storage and conversion facilities on the port site where the unloading equipment is situated. This simplifies our study and ignores inland transport costs. Each supply chain option "o" as described above shall be compared based on the expected levelised cost of hydrogen (or energy) on the Delivered Ex Ship (DES) basis (i.e., delivery to the buyer's port). The



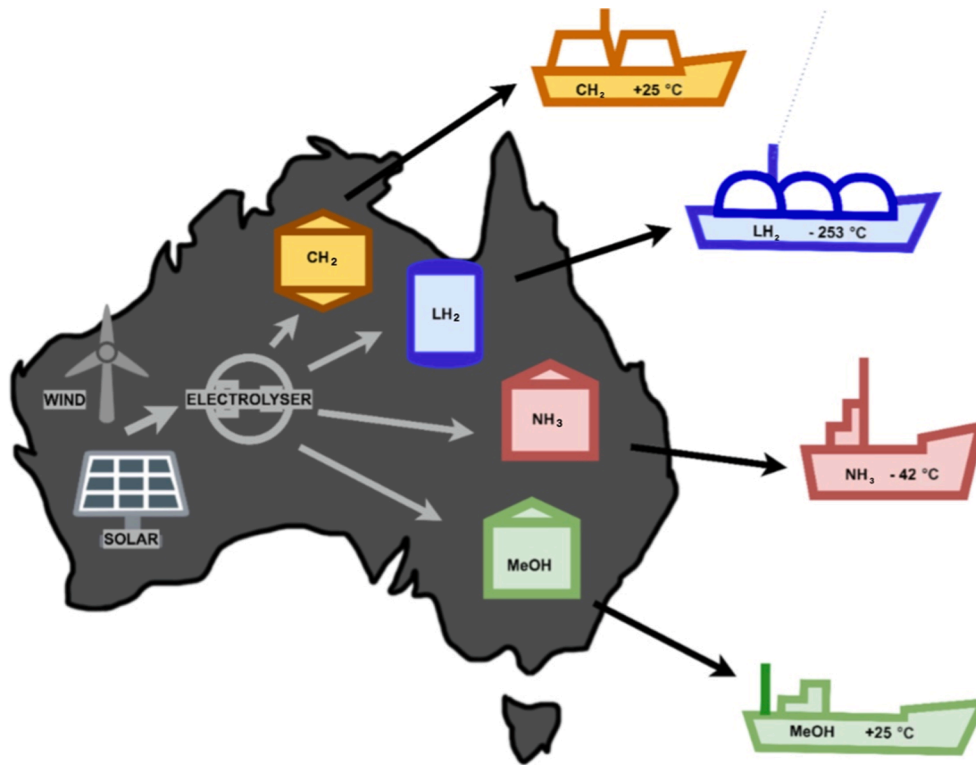

Fig. 2. Green electricity production (e.g., by solar PV and wind) and its export utilisation options.

investment planning time is  $N = 25$  years. The cost of the energy to deliver shall be compared between each option based on the weighted amount of hydrogen (or the low heating value of the product) at the delivery terminal for each type of carrier fuel. For the analysis, we utilise the decision analysis cycle (DAC) discussed next.

### 3. Introduction to decision analysis cycle

Any decision, whether small- or large-scale, is subject to many endogenous or exogenous factors, where it is often impossible to determine the magnitude of all such factors. This makes the act of decision-making a complex task subject to uncertainty and risk of failure. In the quest for tackling this challenge, the term (and later the field of) “decision analysis (DA)” was introduced to address decisions in the face of uncertainty by providing a logical decision-making procedure [66]. DA cycle (DAC) is a form of DA which uses decision theory and systems analysis and integrates the risk preference of the decision-maker by using utility theory and subjective probability. This helps the decision-maker to identify a good decision and achieve clarity of action [67]. As shown in Fig. 4, The DAC framework initiates with the identification of (1) decision criterion, (2) decision alternatives, and (3) decision factors (certain and uncertain parameters). The next step would be the progressive analysis of the decision, i.e., the DA cycle (Fig. 4) comprising three phases of deterministic analysis, probabilistic analysis and information analysis [67]. Its main idea is to continuously eliminate the variables that are not essential to the final decision. The three phases can be repeated based on the updated information or data, or they may end with the identification of the best course of action. For the supply chain problem of the study, we have earlier introduced the decision criterion, as well as the eight supply chain options (including two production and four carrier choices). We will assess the decisions based on two alternative decision criteria : the expected levelized cost of hydrogen (ELCOH) and the expected levelized cost of energy (ELCOE). The techno-economic factors of each option are discussed later. Some uncertain factors include electricity price, technology-specific energy

efficiency and thus electricity consumption rate, capital expenditure (CAPEX), fuel price (affected by crude oil price), ship charter rates, and carbon cost/tax/credit when available (see Fig. 5). Here, we discuss the three DA phases.

**Deterministic phase:** In this phase, the range of uncertain parameters is identified with the quantification of their lower bound, upper bound and base values. Then a sensitivity analysis is performed at the boundaries of each uncertain parameter, but with a deterministic decision criterion (i.e., ELCOH or ELCOE). The outcome is a tornado dominance chart showing the impact of each uncertain factor on the decision criterion and enabling the decision-maker to refine the decision framework with the removal of uncertain parameters which have a negligible impact on the decision criterion.

**Probabilistic phase:** In this phase, the shortlisted uncertain factors are assigned with their probability distribution (using historical data or expert input). The probabilistic decision tree model for the computation of the expected value of the decision criterion (i.e., ELCOH or ELCOE) will be developed (see, for instance, Fig. 6) enabling us to identify the most feasible supply chain option under the given assumptions.

**Informational phase:** Uncertainties are significantly time-dependent, and as information is updated, their value and significance are also affected. When the probability values of uncertain factors are affected, the DA cycle is conducted once again to obtain more accurate results.

Once the DA cycle procedure is concluded, the results can be further investigated by the decision-makers to make their final decisions based on the DA cycle suggestions.

### 4. Supply chain options modelling

#### 4.1. Overall framework

Fig. 5 illustrates the decision model. We have identified electricity price, process energy efficiency (i.e., electricity consumption for production or conversion of one unit of hydrogen energy), CAPEX, ship fuel price, and ship charter rate as parameters with some levels of

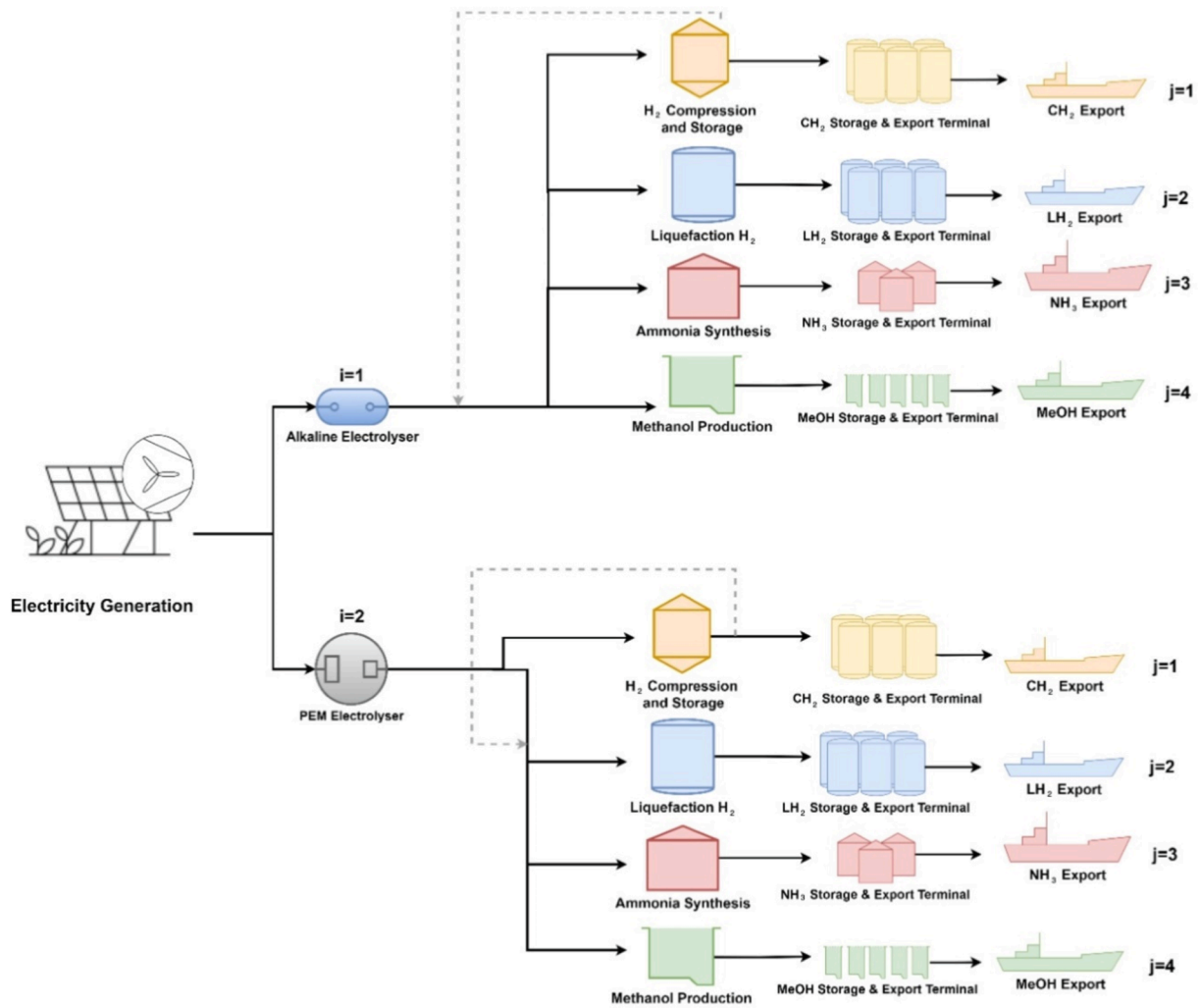

Fig. 3. Overview of hydrogen supply chain with all alternative energy carriers.

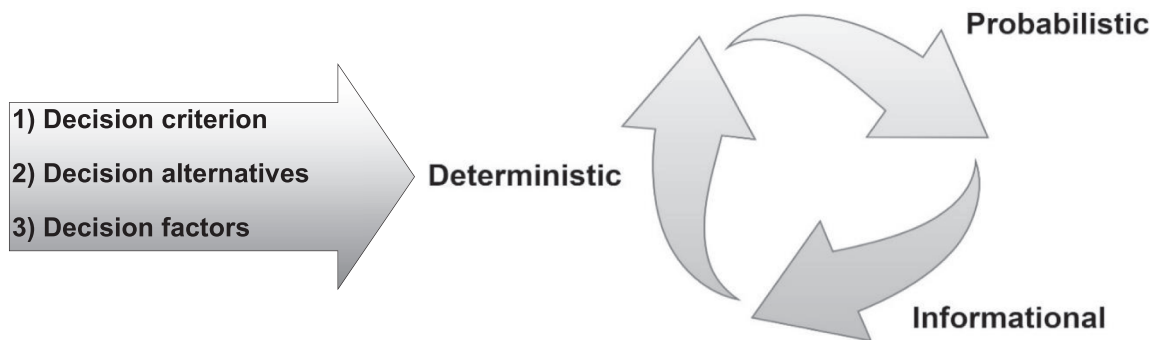

Fig. 4. Phases of the decision analysis cycle (DAC).

uncertainty. It is also noteworthy that although operation expenditure (OPEX) is not directly considered as an uncertain variable, it is indirectly subject to uncertainty due to being a function of the electricity price and production/conversion energy efficiencies. Next, for each of these parameters, we assume a certain number of scenarios with a given probability. The cost of electricity is assumed to be inclusive of all transmission costs to the electrolysers. Assuming  $E$  price scenarios for electricity,  $EP_{en}$  denotes the electricity price for scenario  $e$  ( $1 \leq e \leq E$ ) in year  $n$  ( $1 \leq n \leq N$ ) with a given probability value  $Pr[\text{Scenario } e]$ . Similarly, we assume  $C$  scenarios ( $1 \leq c \leq C$ ) for the CAPEX of each

production  $i$  ( $CX_{ic}$ ) and carrier  $j$  ( $CX_{jc}$ ) option with a given probability value  $Pr[\text{Scenario } c]$ . For each production system  $i$ , we assume  $F$  scenarios for the conversion efficiency of electricity (e.g., in kWh) to hydrogen (e.g., in kgH<sub>2</sub>) denoted by  $\eta_{if}$  ( $1 \leq f \leq F$ ) with allocated probability value  $Pr[\text{Scenario } f]$ . Similarly, we denote the conversion efficiency of the energy carriers considered with  $\eta_{jf}$  ( $1 \leq f \leq F$ ).

Oil price affects various elements in the energy sector including bunker fuel costs. Assuming  $K$  price scenarios for bunker fuel,  $FP_{kn}$  denotes the fuel price for scenario  $k$  ( $1 \leq k \leq K$ ) in year  $n$  with probability  $Pr[\text{Scenario } k]$ . Similarly, assuming  $R$  charter rate scenarios for carriers,

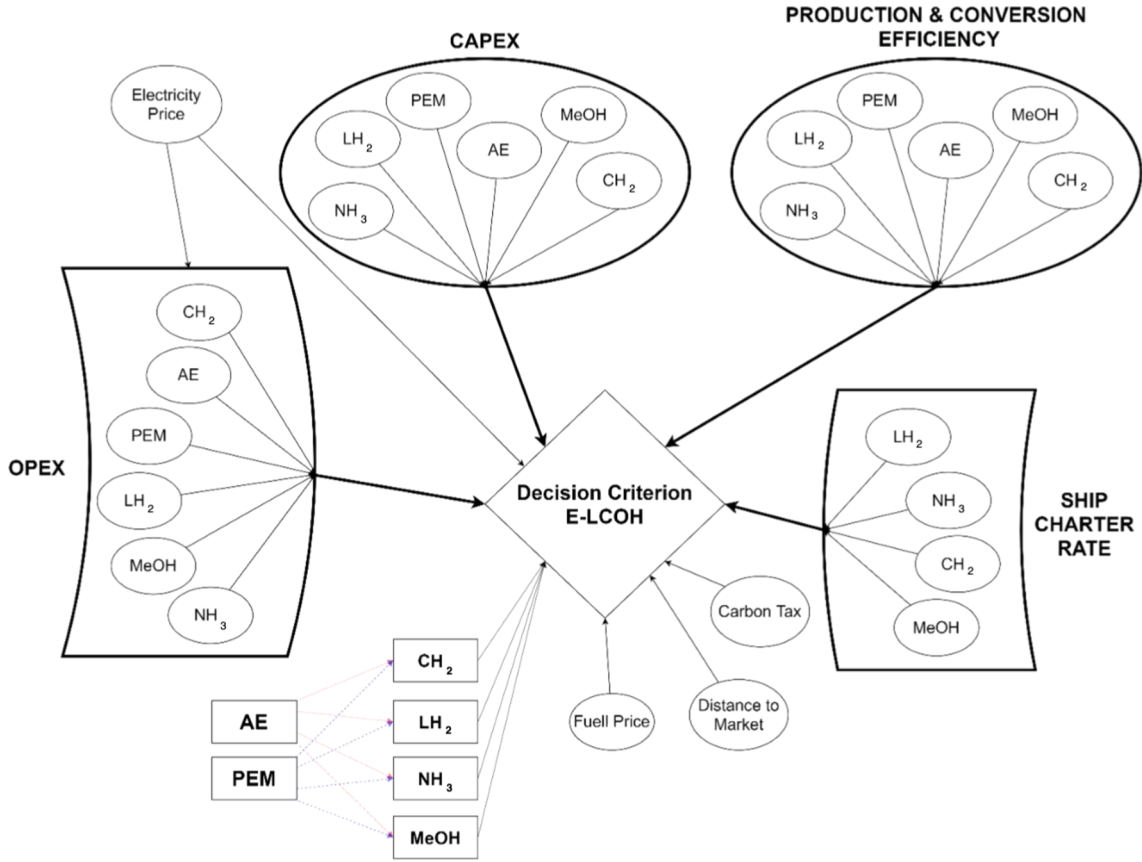

Fig. 5. Decision model for alternative renewable hydrogen vector supply chains including the decision alternatives (utilisation options), decision variables, and the structure of the decision criterion, i.e., the expected levelised cost of hydrogen (ELCOH) for all utilisation options considered.

$CR_{kn}$  denotes the charter rate for scenario  $r$  ( $1 \leq r \leq R$ ) in year  $n$  with  $Pr$  [Scenario  $r$ ]. Where relevant, we assume  $G$  scenarios for greenhouse gas (GHG) tax or credit with  $GP_{gn}$  denoting the GHG cost/tax/credit for scenario  $g$  ( $1 \leq g \leq G$ ) in year  $n$  with  $Pr$ [Scenario  $g$ ]. This gives us a decision tree (Fig. 5) with  $E \times C \times F \times K \times R \times G$  stochastic scenarios for each of the  $O = I \times J$  options tackled.

The decision criterion is the expected levelised cost of hydrogen (ELCOH) over all uncertain scenarios, which is composed of all costs across the value chains including  $H_2$  production, conversion, storage and transport. Each of these costs is calculated separately. The first part is the levelised cost of production (LCOP) which includes hydrogen generation. Then, we have the levelised cost of conversion (LCO) for different carriers, followed by the levelised cost of storage (LCOS), and levelised cost of transport (LCOT) for different energy carriers. In the next sections, the formulations of each of these five factors and the final ELCOH are provided.

#### 4.2. Hydrogen production (electrolyser)

The purchased electricity first enters the hydrogen production unit which is an electrolyser. To produce hydrogen from an electrolyser, a set of interlinked processes are involved that include electricity and water

inputs, electrolysis, pipeline operations, compression, and storage. In this study, two types of electrolysers are considered: Alkaline Electrolyser (AE) ( $i = 1$ ) and Polymer Electrolyte Membrane (PEM) ( $i = 2$ ). The LCOP formulations of both technologies are similar despite their different timelines for stack replacement. Generally, the levelised cost of energy products is given by

$$LCOP = \frac{FCF \times CX + OX_1}{DC \times TPY \times CF}, \quad (1)$$

where  $CX$  is the CAPEX,  $OX_1$  is the OPEX of the plant during year  $n = 1$ ,  $DC$  is the design capacity of the process in terms of unit weight of product per time interval  $\Delta t$ ,  $TPY$  is the number of  $\Delta t$  within a year, and  $CF$  is the annual capacity factor of the plant.  $FCF$  is the fixed charge factor for levelisation of total CAPEX, also known as capital recovery factor or annuity factor. It is given by

$$FCF = \frac{d(1+d)^N}{(1+d)^N - 1}, \quad (2)$$

where  $d$  is the discount rate and  $N$  the expected economic lifetime of the plant. On this basis, the LCOH for hydrogen production is given by

$$LCOP_{wcf} = \left( \frac{FCF \times \left( CX_{ic}^p + \sum_{q=1}^m \left( \frac{SC_{ic,qm}}{(1+d)^{qm}} \right) \left( \frac{SC_{ic,qm}}{(1+d)^{qm}} \right) \right) + FOX_{i1}^p + EP_{e1} \times EC \times TPY}{\eta_{if} \times EC \times TPY \times CF_i} \right) \quad (3)$$

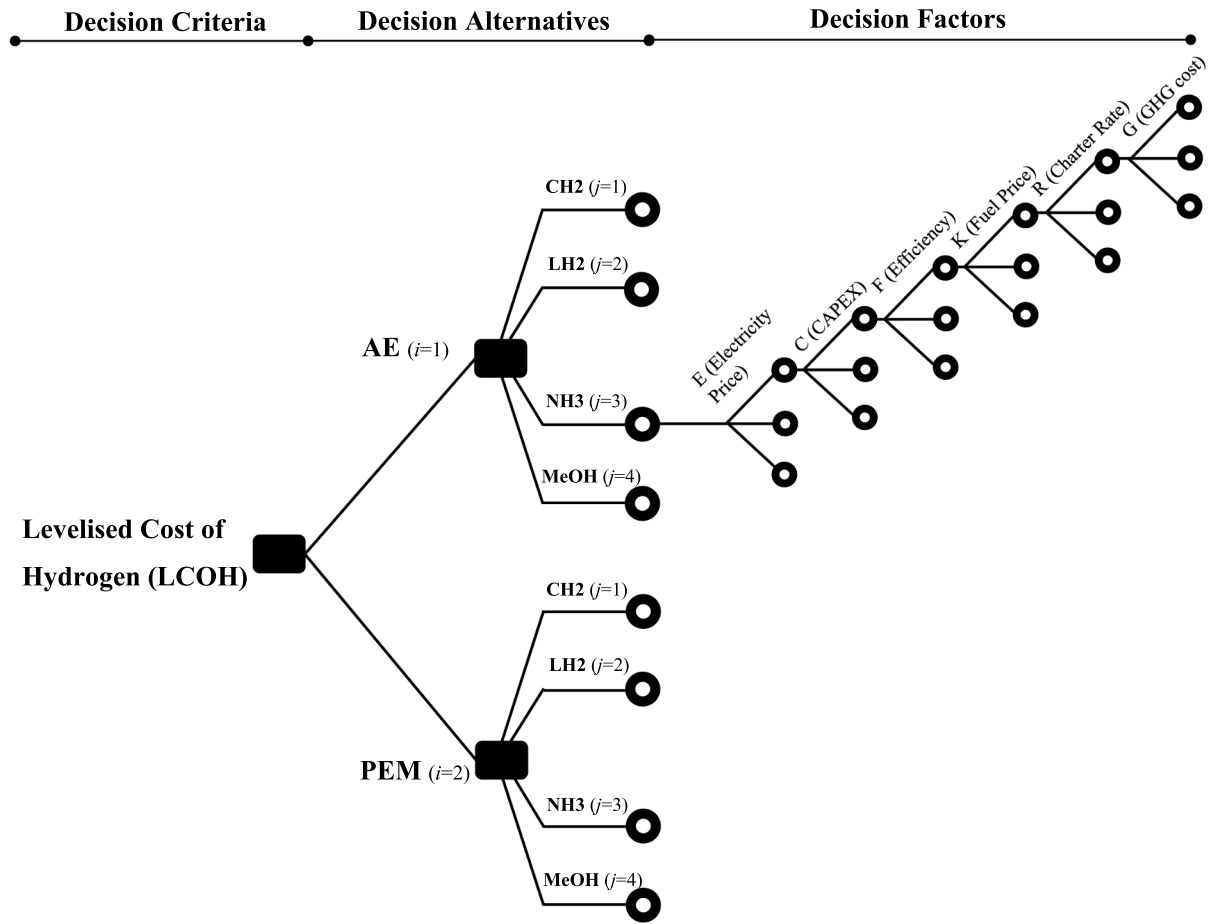

Fig. 6. Decision tree structure for the various options and stochastic scenarios considered.

where  $CX_{ic}^P$  is the CAPEX for electrolyser technology  $i$  at CAPEX scenario  $c$ . The term after the CAPEX in the nominator is related to the stack replacement costs in which  $n_s$  denotes stack life,  $SC_{ic}$  is the stack cost for technology  $i$  and CAPEX scenario  $c$ , and  $q$  denotes the quantity of stacks used.  $\eta_{if}$  is conversion efficiency (input to output) of technology  $i$  at efficiency scenario  $f$ , and  $CF_i$  is the capacity factor of plant  $i$ .  $FOX_{i1}^P$  denotes fixed OPEX of technology  $i$  in the first year of operation.

[68]. Given a different jurisdiction, it may incur a positive (capturing or purchasing pure CO<sub>2</sub>) or negative (CO<sub>2</sub> utilisation) cost ( $GP_g$ ) for delivery of a unit weight of hydrogen ( $\theta_j$ ). As such, the overall LCOC (e.g., in \$/kgH<sub>2</sub>, where \$ refers to the Australian dollar/AUD throughout this article) for these four options is given by

$$LCOC_{jecfg} = \frac{FCF \times CX_{jc}^C + FOX_{j1}^C + EP_{e1} \times HC \times TPY \times \frac{\zeta_{jf}}{\epsilon_{jf}} + GP_{g1} \times HC \times TPY \times CF_j \times \theta_j}{HC \times TPY \times CF_j} \quad (4)$$

### 4.3. Hydrogen storage, carriers and transport

The hydrogen produced from the electrolyser can be delivered to the consumer via four carriers: compressed (CH<sub>2</sub>), liquefied hydrogen (LH<sub>2</sub>), ammonia (NH<sub>3</sub>), and methanol (MeOH). All these carriers require certain (physical or chemical) conversion processes to convert hydrogen into the carriers. For CH<sub>2</sub>, hydrogen must be compressed. Although CH<sub>2</sub> has a very low energy density as compared to the other carriers, it may still be economical for some customers. LH<sub>2</sub> requires cryogenic liquefaction, and ammonia (NH<sub>3</sub>) requires the Haber-Bosch process and air separation. Methanol (MeOH) production requires carbon monoxide (CO) or carbon dioxide (CO<sub>2</sub>) as inputs other than hydrogen. Methanol production is a potential pathway for CO<sub>2</sub> utilisation to useful products

where  $HC$  is the input hydrogen capacity per time interval  $\Delta t$ , (e.g., in kg/hr or tonnes/day) for which  $CX_{jc}^C$  is the associated CAPEX of the conversion and storage facility.  $FOX_{j1}^C$  denotes fixed OPEX of the conversion technology  $j$  in the first year of operation.  $\zeta_{jf}$  denotes the electricity consumption (kWh/kgH<sub>2</sub> consumed) for carrier  $j$ ,  $\epsilon_{jf}$  is the compressor efficiency, and  $CF_j$  is capacity factor, and  $\theta_j$  denotes the amount of CO<sub>2</sub> per weight of H<sub>2</sub> consumed (applicable here only to MeOH).

The hydrogen vector supply chains include two storage facilities. The first one is between the electrolyser and the carrier conversion unit to store enough H<sub>2</sub> to assure operation continuity upon short-term disruption to electrolyser output (e.g., electricity supply variability). The second is for the carrier itself waiting for the arrival of a delivery



tanker. For obvious reasons, the first storage unit is the same for all supply chain routes. However, the second storage unit depends on the carrier. Therefore, the total levelised cost of storage (LCOS) is given by the sum of the levelised cost of storage for production (LCOSP) and that for transport (LCOST),

$$LCOS_{jeff} = LCOSP_{jeff} + LCOST_{jeff} = \frac{FCF \times (CX_{jc}^{SP} + CX_{jc}^{ST}) + FOX_{j1}^S}{HC \times TPY \times UF_j} \quad (5)$$

where  $CX_{jc}^{SP}$  and  $CX_{jc}^{ST}$  are capital expenditures (in \$) of the first and second storage units. It is possible that some decision-makers might consider the first storage unit as a part of the electrolyser unit, and the second storage unit as a component of the conversion unit. We assume that electrolyser, storage facility, and unloading facility lie in proximity, hence the cost associated with inland hydrogen/chemical transport is considered as negligible.

The final element in the value chains is the transport of the energy carrier. The LCOT (levelized cost of transportation per weight per distance) for each option  $j$  which is given by

$$LCOT_{jrk} = \gamma_j \left( \frac{CR_{jr} \left( \frac{2D}{v_j} + \frac{VC_j}{2LR_j} \right) + PC_j \left( \frac{VC_j}{2LR_j} \right) + I_j + FR_j \times FC_{k1} \left( \frac{2D}{v_j} \right)}{VC_j \times w_j \times (1 - \alpha_j \frac{2D}{v_j})} \right) \quad (6)$$

where  $CR_{jr}$  is the ship charter rate (cost per day),  $D$  is the transport distance (laden + ballast),  $FC_j$  is the fuel consumption rate (weight per time) for carrier option  $j$ ,  $v_j$  the vessel speed,  $VC_j$  is the vessel capacity (weight) for the product,  $PC_j$  is the port costs (per day),  $I_j$  is insurance and other costs,  $LR_j$  the filling rate (loading and offloading),  $\gamma_j$  is the complexity factor for each carrier tanker,  $w_j$  is the weight ratio of hydrogen to product and  $FR_j$  is the consumption rate of the fuel for the tanker of carrier  $j$ , and  $FC_{k1}$  is fuel cost per unit weight under fuel price scenario  $k$  in the first year ( $n = 1$ ). The term  $\alpha_j$  refers to the rate of carrier loss during transport due to various reasons including boil-off. These lead to the total LCOH given by

$$LCOH_{ijecfkrjg} = LCO_{jeff} + LCOC_{jeffg} + LCOS_{jeff} + LCOT_{jrk} \quad (7)$$

With these, the supply chain formulation for all pathways is completed. The last step is to compute the expected value of LCOH, i.e., ELCOH over the supply chain and considering all uncertain parameters. This is given by

**Table 1**

Transport distance & time between 20 strategic Australian ports and three international destinations.

Australian key ports [69]	Export distance (NM), and One-way travel time* (days)		
	Singapore (Port Singapore)	Japan (Port Kagoshima)	Germany (Port Bremerhaven)
Port of Gladstone	3577 NM (9 days)	3967 (10)	11,958 (29)
Port of Adelaide	3504 (9)	5299 (13)	11,057 (27)
Port of Hay Point	3356 (8)	3803 (9)	11,737 (29)
Port of Brisbane	3942 (9)	3942 (10)	12,223 (30)
Port of Hobart	3967 (10)	4960 (12)	11,441 (28)
Port of Cairns	3012 (7)	3459 (8)	11,393 (28)
Port of Melbourne	3842 (9)	4950 (12)	11,316 (28)
Port of Newcastle	4214 (9)	4284 (10)	11,830 (29)
Port of Dampier	<b>1660 (4)</b>	<b>3327 (8)</b>	<b>9582 (23)</b>
Port of Port Botany	4279 (18)	4349 (18)	11,759 (29)
Port of Darwin	1887 (5)	2725 (7)	10,221 (25)
Port of Port Hedland	1678 (4)	3273 (8)	9666 (24)
Port of Rockhampton	3541 (9)	4006 (10)	11,922 (29)
Port of Fremantle	2220 (5)	4130 (10)	9780 (24)
Port of Townsville	3170 (8)	3617 (9)	11,551 (28)

\*At a speed of 17 knot

$$ELCOH_{ij} = \sum_{e=1}^E \Pr[e] \times \sum_c^C \Pr[c] \times \sum_f^F \Pr[f] \times \sum_k^K \Pr[k] \times \sum_r^R \Pr[r] \times \sum_g^G \Pr[g] \times LCOH_{ijecfkrjg} \quad (8)$$

Once  $ELCOH_{ij}$  is computed for all eight supply chain options, the probabilistic DAC will be concluded by the recommendation of the path with the lowest expected levelised cost of energy (ELCOE). It is also noteworthy that ELCOH can be easily converted to other forms. For instance, the expected levelised cost of energy (i.e., \$/unit energy) is given by

$$ELCOE_{ij} = \frac{w_j \times ELCOH_{ij}}{LHV_j} \quad (9)$$

where  $ELCOE_{ij}$  denotes the levelised cost of energy (e.g., in \$/GJ),  $LHV_j$  is the lower heating value of carrier  $j$ , and  $w_j$  is the weight conversion ratio of the hydrogen to product (value of one for  $CH_2$  and  $LH_2$ ). Having formulated the decision analysis framework, in the next section, we use a case study to demonstrate the model performance.

### 5. Case Study: Australian renewable energy export

Australia is the world's sixth-largest country, with diverse climate and renewable energy resources. With one of the best solar energy resources, the country has a legitimate interest in considering the potential of exporting its renewable energies to at least the neighbouring ASEAN markets. Otherwise, such resources will be stranded, a situation which is identifiable as resource wastage [25]. Table 1 lists the distance between 20 Australian strategic ports and their trans-ocean distance (and travel time at a speed of 17 knots) to four potential markets in Singapore, Japan, and Germany (as an extreme case). The shortest path is 1660 NM (Nautical Miles) (4 days, one-way) between Port of Dampier and Port Brisbane, with the longest being 12,223 NM (29 days) between Port Brisbane (Australia) and Port Bremerhaven (Germany).

Here our goal is to investigate the feasibility of Australian renewable electricity exports through the hydrogen vector. We wish to identify the most feasible value chain (hydrogen production technology and energy carrier) for exports by calculating the expected levelised cost of hydrogen between any given two export and import points. Table 2 lists the input parameters used for this analysis. To get the most accurate results, we have investigated a wide range of academic and industrial publications and employed the most reliable data. The three stages of the decision analysis cycle for this case are discussed next.

#### 5.1. Deterministic analysis

**Identification of influential decision factors:** We start the decision analysis cycle with the deterministic phase and conduct the sensitivity analysis of the value chain costs for each utilisation option with respect to electricity price, production/conversion efficiency (electricity consumption rates), CAPEX values, bunker fuel price, tanker charter rate, distance to market, and other factors as described in the utilisation options. Fig. 7 shows the tornado diagram for the eight supply chain pathways. The beauty of this way of presentation is that the tornado diagram provides the whole picture of cost comparison and makes it often easy for a diverse audience to visually assess the options investigated. For the present study, it is evident from the figure that there are some differences between (at least some of) the pathways. It is also clear that for any given pathway, some factors have notable impacts on the LCOH compared with others.

As electricity is the main input for hydrogen production, its price has a great significance. The tornado diagram shows that the electricity price and electrolyser efficiency both have a major impact on LCOH for each carrier. CAPEX of production (electrolysers) and conversion units

Table 2

The input economic and design parameters for the energy production and conversion in the Australian case study for the renewable hydrogen vector supply chains depicted in Fig. 5.

Decision variables and parameters	Units of measurement (UoM)	Low	Base	High	References
<b>AE</b>					
Electricity price ( $EP_{en}$ )	\$/MWh	30	50	70	[3,4,58,70,71]
f.o.b equipment cost*	\$/kW	900	1000	1400	
OPEX ( $OX_{ieff}$ ) excluding electricity	% of CAPEX	–	2	–	
Production efficiency ( $\eta_{ij}$ )	kWh/kgH <sub>2</sub>	50	55	60	
Stack life ( $n_s$ )	hrs	–	90,000	–	
Cost of stack ( $SC_{ic}$ )	\$	–	550	–	
Capacity factor ( $CF_i$ )	%	–	85	–	
<b>PEM</b>					
f.o.b equipment cost*	\$/kW	1000	2000	3000	[4,70–73]
OPEX ( $OX_{ieff}$ ) excluding electricity	% of CAPEX	–	2	–	
Conversion efficiency ( $\eta_{ij}$ )	kWh/kgH <sub>2</sub>	45	50	55	
Stack life ( $n_s$ )	Hrs	–	120,000	–	
Cost of stack ( $SC_{ic}$ )	\$/kW	–	700	–	
Capacity factor ( $CF_i$ )	%	–	85	–	
<b>CH<sub>2</sub></b>					
f.o.b equipment cost*	\$/kW	2	2.8	4	[3,58,74,75]
Conversion efficiency ( $\eta_{ij}$ )	kWh/kgH <sub>2</sub>	1.6	2.4	4	
Compressor efficiency	%	–	75	–	
Capacity factor ( $UF_j$ )	%	–	91	–	
<b>LH<sub>2</sub></b>					
f.o.b equipment cost*	\$/kW	7	9	11	[76–79]
Conversion efficiency ( $\eta_{ij}$ )	kWh/kgH <sub>2</sub>	6	9	12	
Capacity factor ( $UF_j$ )	%	–	85	–	
<b>MeOH</b>					
f.o.b equipment cost*	\$/kgMeOH/year	0.7	1	1.2	[3,80]
GHG cost/tax/credit	\$/tonneCO <sub>2e</sub>	20	50	80	
GHG consumption rate	kgCO <sub>2</sub> /kgMeOH	–	1.5	–	
Conversion efficiency ( $\eta_{ij}$ )	kWh/kgMeOH	–	0.40	–	
Hydrogen consumption ratio (considering process loss)	kgH <sub>2</sub> /kgMeOH	–	0.20	–	
<b>NH<sub>3</sub></b>					
f.o.b equipment cost*	\$/kgNH <sub>3</sub> /y	1	1.5	1.7	[54,81,82]
Capacity factor ( $CF_i$ )	%	–	85	–	
Conversion efficiency ( $\eta_{ij}$ )	kWh/kgNH <sub>3</sub>	–	0.486	–	
Hydrogen consumption ratio (considering process loss)	kgH <sub>2</sub> /kgNH <sub>3</sub>	–	0.183	–	

\* For all production/conversion units, the CAPEX is taken as 2.4855 times the f.o.b (free on board) cost of equipment based on Turton's CAPCOST approach [83]. Note. All costs are in Australian dollars (AUD).

also show an important impact on the decision criterion [7]. Therefore, all these decision factors will be carried forward to the probabilistic phase.

The factors with an uneven impact on various supply chain options include the fuel price, charter rate, and distance. From Fig. 7, it can be observed that the fuel price and charter rate have an almost negligible impact on the LH<sub>2</sub>, NH<sub>3</sub> and MeOH supply chains. But, due to the low technological readiness (a compressed gas tanker fleet does not exist yet) and complex transport technologies, compressed hydrogen has a high variation in ship charter rates. If we were comparing only the three options, we could use their nominal values and cease to consider them as uncertain parameters. Still, given that for the CH<sub>2</sub> supply chain these two factors have a significant impact on the decision criterion, thereby we have to keep these two factors as uncertain as well. The last element is distance. Distance is not a decision criterion. We are using a range of distance to demonstrate its impact on the decision criterion, and Fig. 7 clearly shows the significant impact of distance on LCOH particularly for CH<sub>2</sub>. If the distance to market is low, the cost is fairly low for a compressed hydrogen energy chain; however, as the distance increases, the cost of energy increases considerably. In fact, the dependence of CH<sub>2</sub> cost on distance is the most significant factor among all parameters discussed.

**AE vs PEM:** We have intentionally demonstrated the tornado diagram (Fig. 7) in the form of two figures to show the impact of electrolyser choice on the decision criterion. It is visible from the figure that the CAPEX (including stack replacement) for the PEM has a much higher impact on the decision criterion than that for the AE. The impact of conversion efficiency is reverse, though its magnitude is less than CAPEX. Due to the high interest in PEM by researchers, there is an

expectation of cost reduction and a higher conversion efficiency; therefore, there is a higher variation of the CAPEX cost and lower conversion efficiency variance for the PEM. Ultimately, it appears that the CAPEX impacts dominate that of conversion efficiency, and in general, the supply chain options with AE show relatively lower LCOH compared with the PEM (Fig. 7). There are elaborated discussions on this in the following Section 5.2.

**Overall cost implications:** The tornado diagram summarises all the costs associated with each energy option. If we consider ammonia, liquefied hydrogen and methanol as energy carrier options, these have comparable costs that lie between 6 and 12 \$/kgH<sub>2</sub>. However, the lowest cost of the supply chain lies with methanol as an energy carrier. Considering the least input cost variance, fuel price and charter rate are the only factors that do not impact the overall cost of energy for those three carrier energy options. If those options are assessed separately, the mentioned two factors can be fixed at their base values.

## 5.2. Probabilistic analysis

The results from the deterministic analysis presented in Fig. 7 clearly show the impact of uncertainties or variations in electricity price, energy efficiency, CAPEX, charter rate, distance to market and fuel price on the LCOH. Therefore, we keep these uncertain parameters for the probabilistic analysis phase. For each uncertain parameter, we use a three-point probability distribution with low at a probability of 25 %, base at 50 %, and high with a probability of 25 %. This makes the decision tree (see Fig. 6) with  $(2 \times 4) \times (3 \times 3 \times 3 \times 3 \times 3) = 1944$  possibilities. Given that CO<sub>2</sub> is only consumed for the MeOH process, here we assume the median cost of 50 \$/tonneCO<sub>2e</sub> as reported in Table 2.

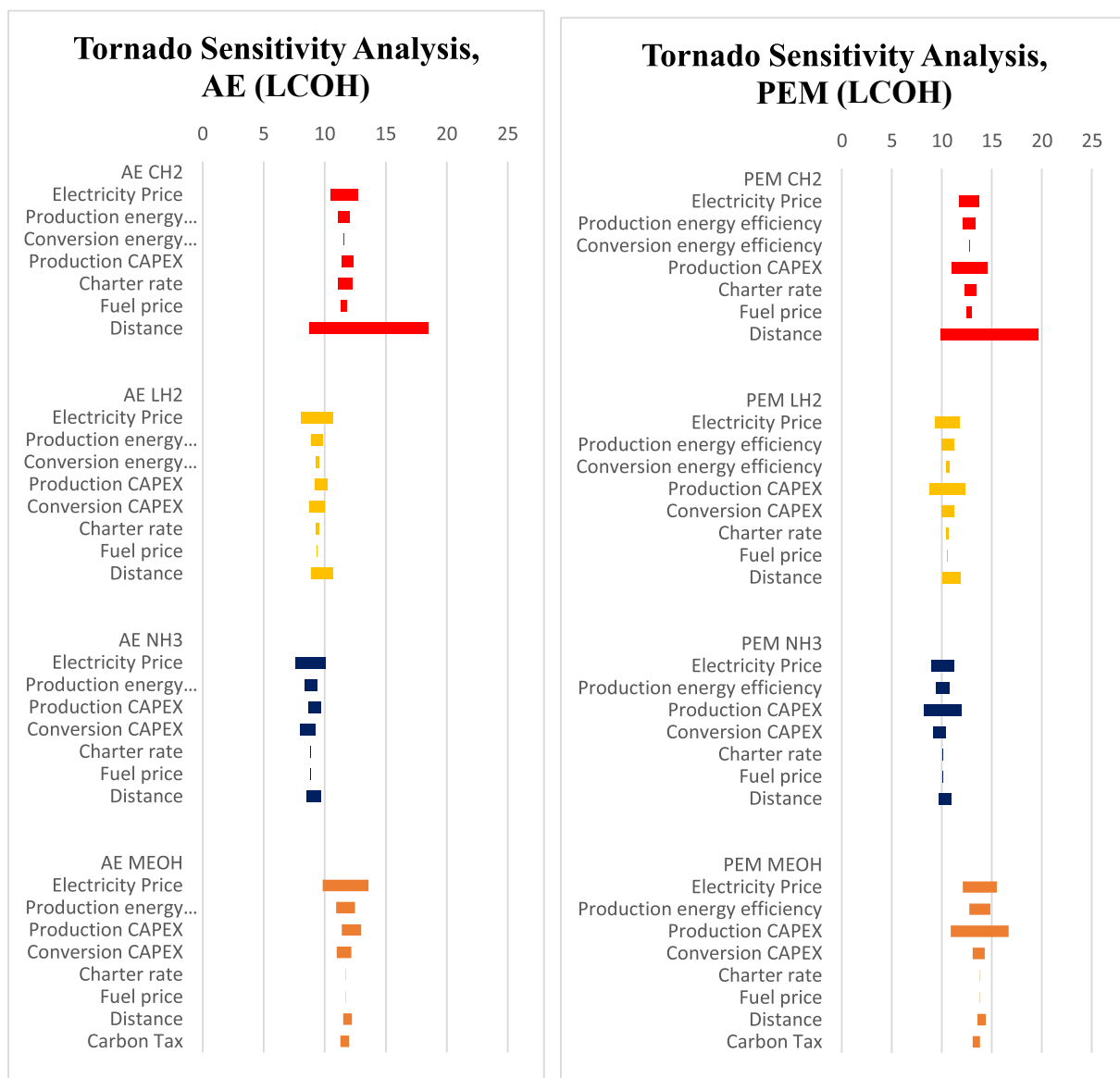

Fig. 7. Tornado sensitivity analysis for the LCOH of different supply chain options (composed of a combination of PEM, AE, and CH<sub>2</sub>, LH<sub>2</sub>, NH<sub>3</sub>, MeOH) against the key decision factors (based on data reported in Table 2).

The analysis results for a market distance of 4000 NM are illustrated in Fig. 8 a). The results show a different pattern for the two decision criteria (ELCOH and ELCOE). When the decision criterion is hydrogen content, i.e. ELCOH (\$/kgH<sub>2</sub>), the model finds AE-NH<sub>3</sub> as the most optimal supply chain path for this case study with 8.87 \$/kgH<sub>2</sub>, followed by AE-LH<sub>2</sub> as the second-best option at a value of 9.05 \$/kgH<sub>2</sub>. Interestingly, in this regard, MeOH proves to be the least attractive path. Nevertheless, with the decision criterion of energy content, i.e. ELCOE (\$/GJ), AE-MeOH proves to be the most feasible path (74.57 \$/GJ) followed by AE-LH<sub>2</sub> as the second-best option (79.36 \$/GJ). This creates an interesting discussion on whether our objective is hydrogen export or renewable energy export. If the objective is hydrogen export, MeOH is the least attractive process mainly because part of the inlet H<sub>2</sub> is undesirably converted to water during methanol synthesis process (CO<sub>2</sub> + 3H<sub>2</sub> → CH<sub>3</sub>OH + H<sub>2</sub>O). However, from an energy content point of view, MeOH is the best solution due to its high LHV. This implies that the ultimate use of these chemicals may also affect the choice of decision criterion, and that impacts the option chosen as the most preferable one.

Fig. 8 b) also provides a higher resolution of the results based on the cost components of each supply chain path. As becomes evident from the

figure, transport (LCOT) is the detrimental element in CH<sub>2</sub> supply chain feasibility compared with other options.

### 5.3. The best options for a given market

In the previous section, we demonstrated the DAC framework performance, and we executed one example for a market at a distance of 4000 NM. Here, we run three rounds of that analysis for export scenarios with destinations Singapore, Japan, and Germany from the Australian Port of Dampier, with distances of 1660, 3327, and 9582 NM, respectively (see Table 1). Fig. 9 shows the two best supply chain paths for each of the market locations using the two decision criteria.

The overall trend is that, when the decision criteria is hydrogen content, for all three destinations, the model selects AE-NH<sub>3</sub> as the best path followed by AE-LH<sub>2</sub> as the second-best path. For Singapore (Australian port Dampier to Singapore port), the ELCOH values are 8.56 \$/kgH<sub>2</sub> and 9.05 \$/kgH<sub>2</sub> for AE-NH<sub>3</sub> and AE-LH<sub>2</sub>, respectively. The values for Japan (Australian port Dampier to Japanese port Kagoshima) are obviously higher than those for Singapore: 8.78 \$/kgH<sub>2</sub> and 9.39 \$/kgH<sub>2</sub> for AE-NH<sub>3</sub> and AE-LH<sub>2</sub>, respectively. The values become 9.63

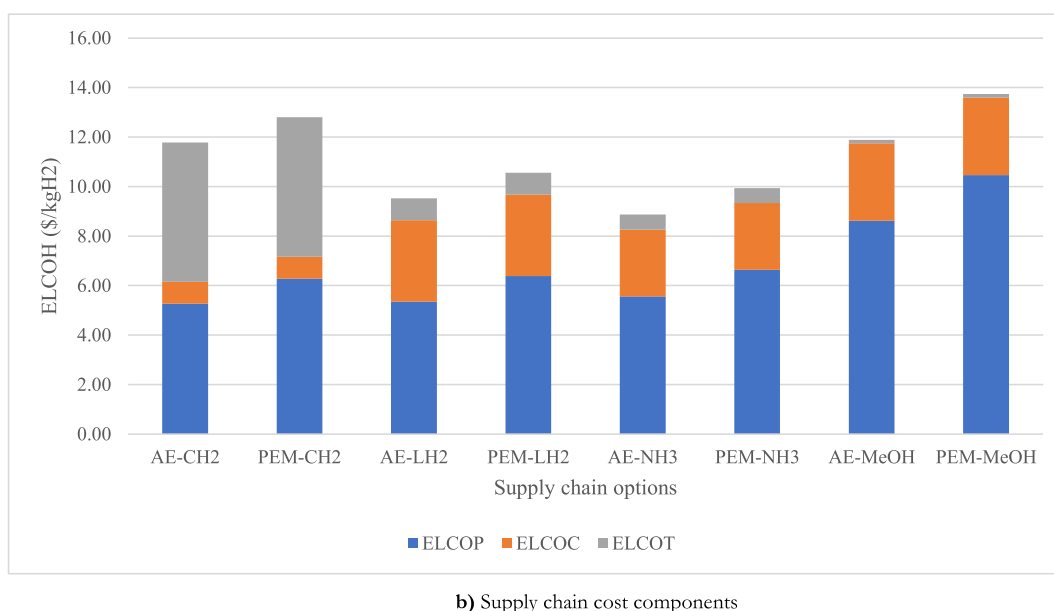
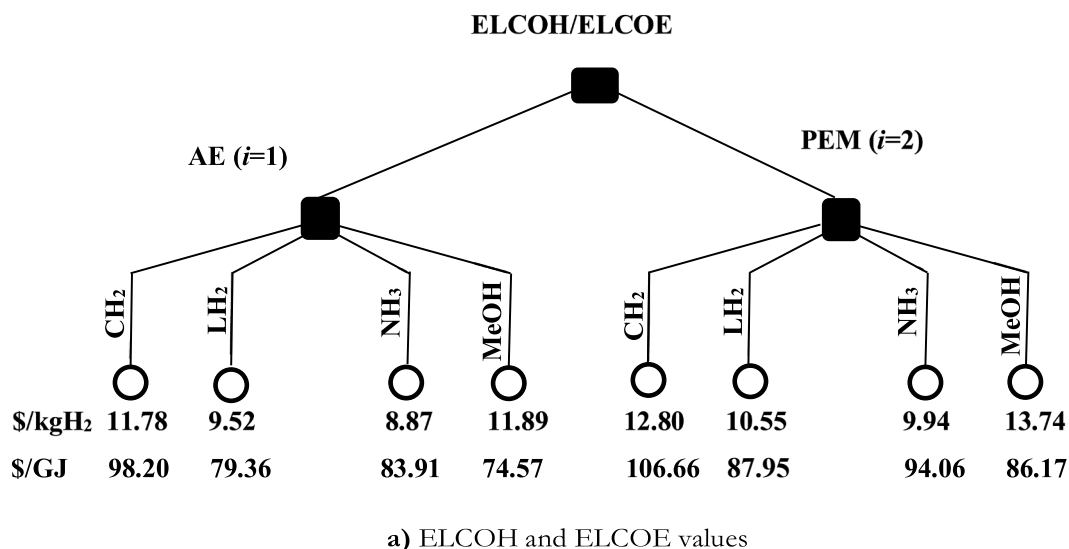

Fig. 8. The probabilistic analysis results for exporting hydrogen from Australia to a market located at 4000 NM distance.

\$/kgH<sub>2</sub> and 10.70 \$/kgH<sub>2</sub> for AE-NH<sub>3</sub> and AE-LH<sub>2</sub>, respectively, for Germany (Australian port Dampier to German port Bremerhaven).

However, when the decision criterion is the energy content, for all three destinations, the model selects AE-MeOH as the best path, still AE-LH<sub>2</sub> keeps its second place, and AE-NH<sub>3</sub> becomes the third-best path. One key observation here is the difference between the first and second options for various distances. When the distance is short or medium, there is a small difference between the two options, but for long distances the first option (AE-MeOH) has clear attractiveness. For instance, for Singapore, the ELCOE values for AE-MeOH and AE-LH<sub>2</sub>, are 73.34 \$/GJ vs 75.39 \$/GJ. The values for Japan are 74.21 \$/GJ vs 78.21 \$/GJ. This gap for Germany becomes 77.65 \$/GJ vs 89.17 \$/GJ.

As a conclusion and for visual demonstration, Fig. 10 illustrates a comparison of different energy carrier options versus a trip distance of 1500–10000 NM and for two decision criteria of a) ELCOH (\$/kgH<sub>2</sub>) and b) ELCOE (\$/GJ). From Fig. 10 a) for the ELCOH criterion, it is easy to identify NH<sub>3</sub> as the least-cost option, followed by LH<sub>2</sub> and MEOH, leaving CH<sub>2</sub> as the least preferable option. However, the lowest cost of transport is incurred by MeOH due to its physical state at ambient temperature, followed by NH<sub>3</sub> and LH<sub>2</sub>, respectively. This can also explain why MeOH has the least variation in cost over wide travel

distances: NH<sub>3</sub> and LH<sub>2</sub> have a slightly steeper gradient in comparison to MeOH. However, the cost of transporting CH<sub>2</sub> becomes significantly higher when the journey distance is increased and this is visually evident from the figure. From Fig. 10 b), for the ELCOE criterion, it can be observed that methanol becomes the best route across the destination range.

#### 5.4. Impact of CO<sub>2</sub> price/tax/credit

A key challenge in the analysis of international supply chains is the legislative issues in terms of emissions. For instance, MeOH process utilises carbon dioxide (3H<sub>2</sub> + CO<sub>2</sub> → CH<sub>3</sub>OH + H<sub>2</sub>O) which can attract carbon credit in the supply side region. However, on the demand side, the reverse process will emit CO<sub>2</sub> which can lead to carbon taxation. Looking also at the overall supply chain, the process can be considered as nearly CO<sub>2</sub>-neutral. At this point of time, it is not clear how in the future such issues will be dealt with. In this study, to be neutral (and fair with other alternatives) we did not consider CO<sub>2</sub> utilisation in methanol process as a carbon credit [55]. Instead, we considered the cost for pure CO<sub>2</sub> (obtained from available carbon capture processes).

For readers' interest, we have calculated the impact of CO<sub>2</sub> cost on

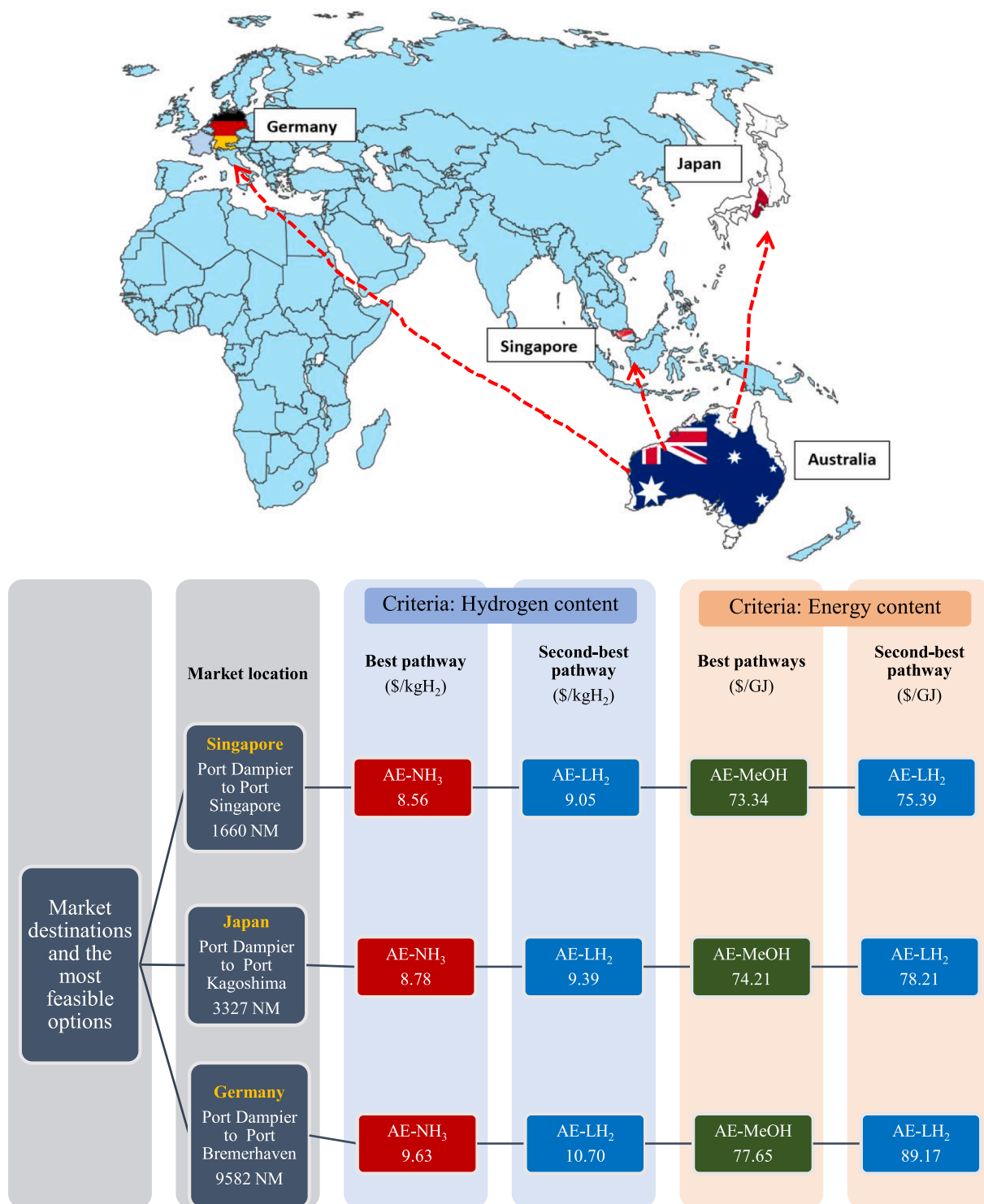

Fig. 9. The probabilistic analysis results for four market locations. Tornado Sensitivity Analysis for PEM, AE and CH<sub>2</sub>, LH<sub>2</sub>, NH<sub>3</sub> and MeOH for parameters and data (Table 2) used in the case study.

the ELCOH of methanol option. Fig. 11 shows the ELCOH at four CO<sub>2</sub> cost values of 0, 20, 50 and 80 \$/tonne CO<sub>2</sub>. While, at zero price for CO<sub>2</sub>, the ELCOH is 11.8 \$/kgH<sub>2</sub> for AE-MeOH, the values increase roughly by 1 % for every 10\$/tonne-CO<sub>2</sub> cost increase. For instance, at 20\$/tonne-CO<sub>2</sub>, the ELCOH increases by 2.16 % to 12.03 \$/kgH<sub>2</sub>, and it increases by 8.6 % to 12.80 at 80\$/tonne-CO<sub>2</sub>. A similar trend can be observed for PEM-MeOH as well when the other criterion (ELCOE) is used.

### 6. Conclusions

Remarkable advances in renewable energy technologies and prices over the last decade have created two inter-related interests in the supply and demand sides of decarbonisation. On the demand side, it has promoted the ambitions to the realisation of net-zero emission planning. This necessitates decarbonisation not only of electricity sectors but also sectors using other energy sources such as fuel for transport services or



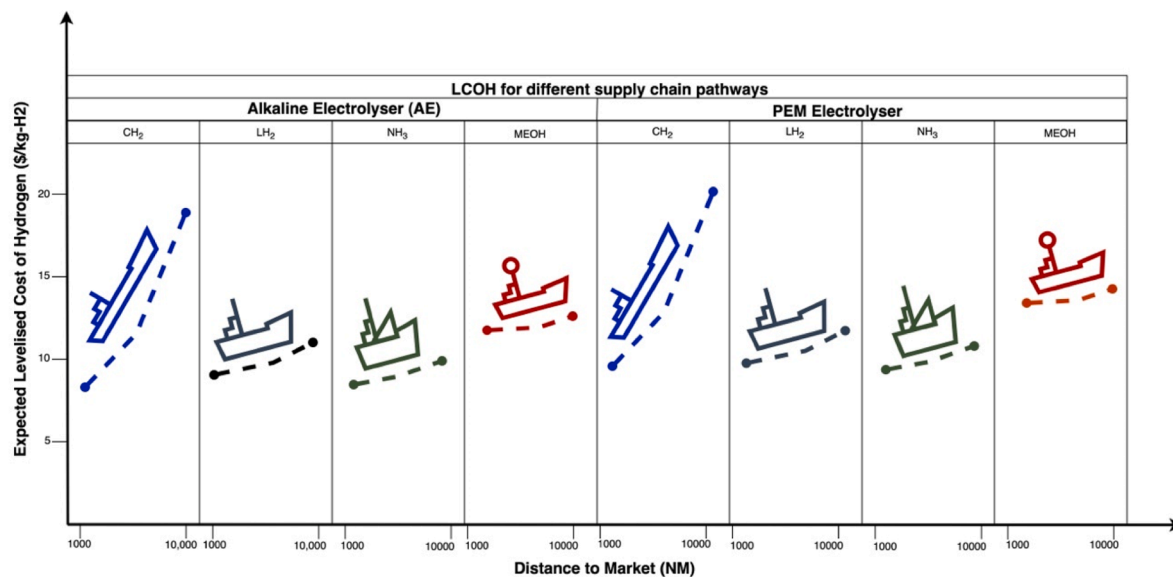

a) Expected LCOH

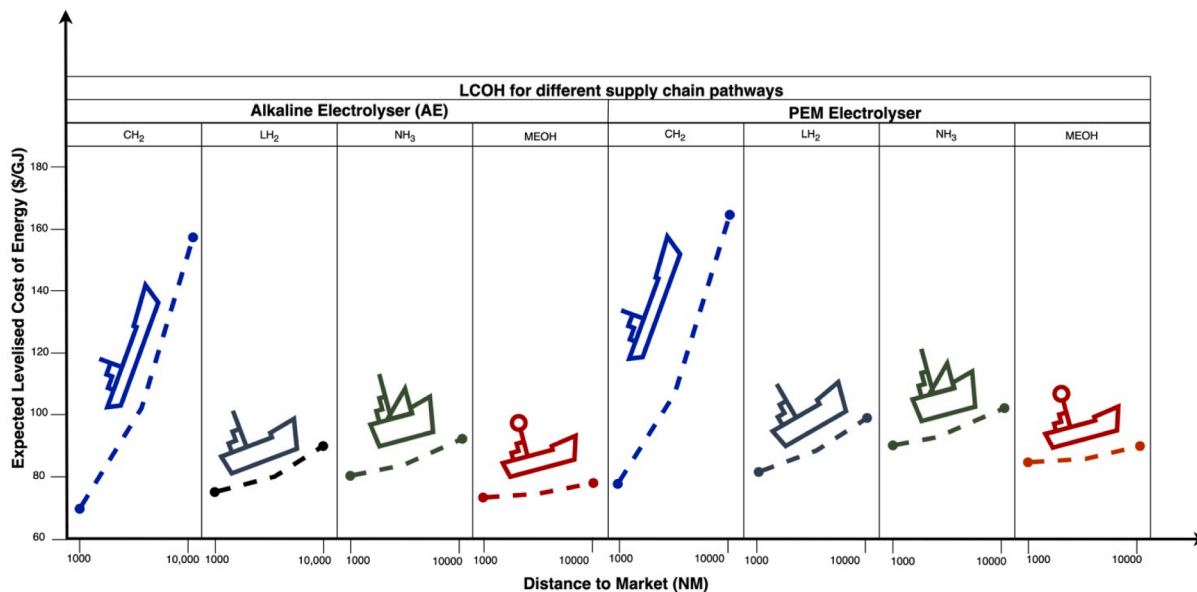

b) Expected LCOE

Fig. 10. Cost sensitivity of the supply chain options to demand market distance (variation. 1500 NM-10000 NM) using the two decision criteria a) ELCOH (\$/kgH<sub>2</sub>) and b) ELCOE (\$/GJ).

manufacturing. Achieving this goal requires alternative forms of renewable energy, which leads to the context of the hydrogen economy. On the supply side, the regions with high-quality renewable energy resources are now motivated to utilise these resources not only for their domestic energy need but also for global export. This movement has already initiated bipartisan cooperation between some energy exporting countries and some with abundant renewable energy resources as well as the supporting infrastructure.

This paper looked at the problem from the supply side, where a resourceful region is exploring renewable energy exports. It considered renewable energy export options based on a hydrogen vector to markets that are reached offshore via shipping. The complexity of this decision-making problem was elaborated, and with evidence from the literature, the need for a rigorous decision analysis framework was justified. We

then introduced a probabilistic decision support tool based on the decision analysis cycle and with consideration of several key decision factors as uncertain parameters (e.g., CAPEX, electricity price, technology efficiency, distance to market and ship charter rate). As a case study, we used eight supply chain options based on two electrolyser technologies (AE and PEM) for hydrogen production, and four shipping options, namely compressed hydrogen (CH<sub>2</sub>), liquefied hydrogen (LH<sub>2</sub>), methanol (MeOH), and ammonia (NH<sub>3</sub>). The key research question was to find out the most preferable option in terms of cost minimisation. The framework calculates the entire energy supply chain costs of production, transmission, storage, conversion, and transport of hydrogen of all alternative energy carriers in the form of expected levelised cost of hydrogen content per unit weight.

The tornado analysis of the decision factors justified that all our pre-

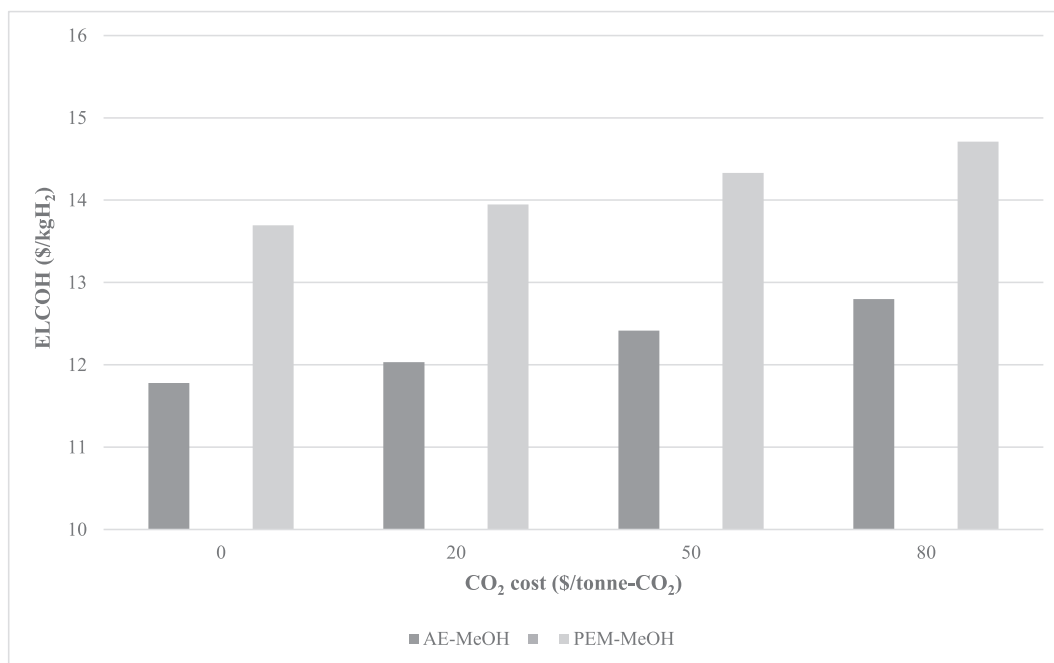

Fig. 11. Impact of carbon cost values on ELCOH of MeOH for 0, 20, 50 and 80 \$/tonneCO<sub>2</sub> for a market destination of 10000 NM.

selected uncertain parameters were important and had to be kept in the probabilistic analysis. It also showed the somehow outlier features of the CH<sub>2</sub> carrier compared with the other three options. This observation was repeated in later analyses and the judgement was reinforced. We conducted supply chain analysis for three routes from Australia to Singapore, Japan and Germany. The model was able to identify the most feasible supply chain options for each of the given distances. The results clearly showed the complexity of decision making induced by multiple factors. One of the key outcomes of the study was the importance of decision criteria. When the objective was the minimum cost per quantity of delivered hydrogen (i.e., ELCOH), the results appeared to be different compared to when the objective was the minimum cost per quantity of energy (i.e., ELCOE). For ELCOH (\$/kgH<sub>2</sub>), for the case study, under the given input parameters, the Ammonia combination with alkaline electrolyzers (AE-NH<sub>3</sub>) becomes the least-cost supply chain option for Singapore, Japan, and Germany with ELCOH of 8.60, 8.78 and 9.63 \$/kgH<sub>2</sub>, respectively. The second-least-cost supply chain for Singapore, Japan and Germany is liquid hydrogen (alkaline electrolyzers) with ELCOH of 9.05, 9.39 and 10.7 \$/kgH<sub>2</sub>, respectively. However, when we used ELCOE (\$/GJ), AE-MeOH became the preferred supply chain path for all destinations, and AE-LH<sub>2</sub> kept its place as the second-best alternative.

Last but not the least, the methodology is generic, the input values presented in this study were taken from published documents. As the technologies enhance and input data are updated, future researchers may need to re-execute the analysis for a more realistic analysis of their time and region.

#### CRedit authorship contribution statement

**Muhammad Aadil Rasool:** Conceptualization, Methodology, Data curation, Writing – original draft, Visualization. **Kaveh Khalilpour:** Supervision, Conceptualization, Methodology, Writing – review & editing. **Ahmad Rafiee:** Methodology, Writing – review & editing. **Iftekhar Karimi:** Methodology, Writing – review & editing. **Reinhard Madlener:** Methodology, Writing – review & editing.

#### Declaration of Competing Interest

The authors declare that they have no known competing financial interests or personal relationships that could have appeared to influence the work reported in this paper.

#### Data availability

Data, used for the research, is provided in the article.

#### References

- [1] Cheng Cheng LH. The role for offshore wind power in renewable hydrogen production in Australia. *J Clean Prod* 2023;391(136223).
- [2] Hancock L, Ralph N. A framework for assessing fossil fuel 'retrofit' hydrogen exports: Security-justice implications of Australia's coal-generated hydrogen exports to Japan. *Energy* 2021;223:119938.
- [3] IEA. The Future of Hydrogen. 2019: G20 Osaka Summit.
- [4] IRENA. Hydrogen from renewable power: Technology outlook for the energy transition. 2018 International Renewable Energy Agency, International Renewable Energy Agency: Abu Dhabi.
- [5] Agency EE. A future based on renewable energy. *Signals* 2022 2022 06 Dec 2022 23 Feb 2023; Available from: <https://www.eea.europa.eu/signals/signals-2022/articles/a-future-based-on-renewable-energy>.
- [6] Boudellal M. Power-to-gas: renewable hydrogen economy for the energy transition. 2023: De Gruyter.
- [7] Agyekum EB, et al. A critical review of renewable hydrogen production methods: factors affecting their scale-up and its role in future energy generation. *Membranes* 2022;12(2):173.
- [8] Reed J, et al. Potential evolution of the renewable hydrogen sector using California as a reference market. *Appl Energy* 2023;331:120386.
- [9] Kar SK, et al. Overview of hydrogen economy in Australia. *WIREs Energy Environ* 2023;12(1):e457.
- [10] Heiserman DL. Exploring chemical elements and their compounds. Tab Books; 1992.
- [11] Boyle R. Tracts, containing new experiments, touching the relation Betwixt Flame and Air. London: Richard Davis; 1673.
- [12] Cavendish H. Three papers, containing experiments on factitious air. *Philos Trans* 1766; 56. p. 141-184.
- [13] ucdsb. Origins of Elemental Names. 2019 [cited 2019 Apr. 11]; Available from: [http://www2.ucdsb.on.ca/tiss/stretton/Database/element\\_origins.html](http://www2.ucdsb.on.ca/tiss/stretton/Database/element_origins.html).
- [14] Valladares MRD. Global trends and outlook for hydrogen. IEA Hydrogen; 2017.
- [15] Rafiee A, Khalilpour KR. Chapter 11 - renewable hybridization of oil and gas supply chains, in polycogenation with polystorage for chemical and energy hubs, K.R. Khalilpour, Editor. Academic Press; 2019. p. 331-72.
- [16] Iplik E, Aslanidou I, Kyprianidis K. Hydrocracking: a perspective towards digitalization. *Sustainability* 2020;12(17):7058.

- [17] Ghavam S, et al. Sustainable ammonia production processes. *Front Energy Res* 2021;9(34):1–19.
- [18] Liu X, Elgowainy A, Wang M. Life cycle energy use and greenhouse gas emissions of ammonia production from renewable resources and industrial by-products. *Green Chem* 2020;22(17):5751–61.
- [19] Cleantech NM. Norwegian future value chains for liquid hydrogen.
- [20] Farrell AE, Keith DW, Corbett JJ. A strategy for introducing hydrogen into transportation. *Energy Policy* 2003;31(13):1357–67.
- [21] James BD, DeSantis DA, Saur G. Hydrogen production pathways cost analysis (2013–2016). Strategic Analysis Inc., Arlington, VA (United States); 2016.
- [22] Metz B, et al. IPCC special report on carbon dioxide capture and storage. Cambridge: Cambridge University Press, for the Intergovernmental Panel on Climate Change. x, 431 p; 2005.
- [23] Osman AI, et al. Recent advances in carbon capture storage and utilisation technologies: a review. *Environ Chem Lett* 2020.
- [24] Khalilpour KR, Vassallo A. Community energy networks with storage: modeling frameworks for distributed generation. Springer Singapore; 2016.
- [25] Khalilpour K. Polygeneration with polystorage: for chemical and energy 1ed. stranded renewable energies, beyond local security, toward export: a concept note on the design of future energy. *Chem Supply Chains* 2019.
- [26] IEA-ETSAP. Hydrogen production & distribution; 2014.
- [27] Li Z, et al. Photoelectrochemical cells for solar hydrogen production: current state of promising photoelectrodes, methods to improve their properties, and outlook. *Energy Environ Sci* 2013;6(2):347–70.
- [28] Andersson J, Grönkvist S. Large-scale storage of hydrogen. *Int J Hydrogen Energy* 2019;44(23):11901–19.
- [29] Heinemann N, et al. Enabling large-scale hydrogen storage in porous media – the scientific challenges. *Energy Environ Sci* 2021;14(2):853–64.
- [30] Karakilcik H, Karakilcik M. Underground large-scale hydrogen storage, in accelerating the transition to a 100% renewable energy Era. Uyar TS, editor. Springer International Publishing: Cham; 2020. p. 375–92.
- [31] Binger U, et al. 7 - Large-scale underground storage of hydrogen for the grid integration of renewable energy and other applications. In: Ball M, Basile A, Veziroglu TN, editors. *Compendium of Hydrogen Energy*. Woodhead Publishing: Oxford; 2016. p. 133–163.
- [32] Mei Zhou YW, Yuchun Chu, Youning Tang, Koukou Tian, Songsheng Zheng, Jin Chen, Zhaolin Wang. Ammonia as an environmentally benign energy carrier for the fast growth of China. In: 10th International Conference on Applied Energy (ICAE2018), 22–25 August 2018, Hong Kong, China; 2019. 158: p. 4986–4991.
- [33] HydroEurope. Hydrogen transport & distribution. 2016 [cited 2019 Apr. 15]; Available from: <https://hydrogeneurope.eu/hydrogen-transport-distribution>.
- [34] Hu G, et al. A review of technical advances, barriers, and solutions in the power to hydrogen (P2H) roadmap. *Engineering* 2020;6(12):1364–80.
- [35] Cerniauskas S, et al. Options of natural gas pipeline reassignment for hydrogen: Cost assessment for a Germany case study. *Int J Hydrogen Energy* 2020;45(21):12095–107.
- [36] Trygve Riis GS, Ulleberg Øystein, Vie Preben JS. Hydrogen production and storage: R&D Priorities and Gaps; 2006.
- [37] Møller KT, et al. Beyond hydrogen storage—metal hydrides as multifunctional materials for energy storage and conversion. *Inorganics* 2020;8(11).
- [38] Becker WL, Penev M, Braun RJ. Production of synthetic natural gas from carbon dioxide and renewably generated hydrogen: a techno-economic analysis of a power-to-gas strategy. *J Energy Res Technol* 2018;141(2):11.
- [39] Abidin Z, et al. Hydrogen as an energy vector. *Renew Sustain Energy Rev* 2020;120:109620.
- [40] Biswas S, et al. A review on synthesis of methane as a pathway for renewable energy storage with a focus on solid oxide electrolytic cell-based processes. *Front Energy Res* 2020;8(229):1–23.
- [41] Dybkjaer I. Ammonia production processes. In: Nielsen A, editor. *Ammonia: catalysis and manufacture*. Springer Berlin Heidelberg: Berlin, Heidelberg; 1995. p. 199–327.
- [42] Kobayashi H et al. Science and technology of ammonia combustion. *Proc Combust Inst* 2019; 37(1): p. 109–133.
- [43] MacFarlane DR, et al. A roadmap to the ammonia economy. *Joule* 2020;4(6):1186–205.
- [44] Simon Araya S, et al. A review of the methanol economy: the fuel cell route. *Energies* 2020;13(3):596.
- [45] Bos MJ, Kersten SRA, Brillman DWF. Wind power to methanol: Renewable methanol production using electricity, electrolysis of water and CO<sub>2</sub> air capture. *Appl Energy* 2020;264:114672.
- [46] Roode-Gutzmer QI, Kaiser D, Bertau M. Renewable methanol synthesis. *ChemBioEng Rev* 2019;6(6):209–36.
- [47] Michailos S, et al. Dimethyl ether synthesis via captured CO<sub>2</sub> hydrogenation within the power to liquids concept: A techno-economic assessment. *Energy Convers Manage* 2019;184:262–76.
- [48] Khalilpour KR, Polygeneration with polystorage: for chemical and energy hubs. Elsevier Science; 2018.
- [49] Taylor CE, Howard BH, Myers CR. Methanol conversion for the production of hydrogen. *Ind Eng Chem Res* 2007;46(26):8906–9.
- [50] Abashar MEE. Ultra-clean hydrogen production by ammonia decomposition. *J King Saud Univ - Eng Sci* 2018;30(1):2–11.
- [51] Wijayanta AT, et al. Liquid hydrogen, methylcyclohexane, and ammonia as potential hydrogen storage: Comparison review. *Int J Hydrogen Energy* 2019;44(29):15026–44.
- [52] Thomas S, Dawe RA. Review of ways to transport natural gas energy from countries which do not need the gas for domestic use. *Energy* 2003;28(14):1461–77.
- [53] Khalilpour R, Karimi IA. Investment portfolios under uncertainty for utilizing natural gas resources. *Comput Chem Eng* 2011;35:1827–37.
- [54] Bruce S, TM, Hayward J, Schmidt, MCE, Palfreyman D, Hartley P. National Hydrogen Roadmap. CSIRO: Australia; 2018.
- [55] Nascimento G, da Silva PRRR, Szkio A. Renewable hydrogen production to deal with wind power surpluses and mitigate carbon dioxide emissions from oil refineries. *Appl Energy* 2022:311.
- [56] Carmo M, et al. A comprehensive review on PEM water electrolysis. *Int J Hydrogen Energy* 2013;38:4901–34.
- [57] Matzen M, Alhajji M, Demirel Y. Technoeconomics and sustainability of renewable methanol and ammonia productions using wind power-based hydrogen. *J Adv Chem Eng* 2015;5(3).
- [58] Hydrogen-Strategy-Group, *Hydrogen for Australia's Future*. 2018, COAG Energy Council: Commonwealth of Australia.
- [59] Khalilpour R, Karimi IA. Evaluation of utilization alternatives for stranded natural gas. *Energy* 2012;40(1):317–28.
- [60] Hao Y. The relationship between renewable energy consumption, carbon emissions, output, and export in industrial and agricultural sectors: evidence from China. *Environ Sci Pollut Res* 2022;29(42):63081–98.
- [61] Hannah Hyunah Cho VS, Evans Tim J. A review on global warming potential, challenges and opportunities of renewable hydrogen production technologies. *Sustain Mater Technol*; 2023. 35.
- [62] Liu W, et al. Green hydrogen standard in China: Standard and evaluation of low-carbon hydrogen, clean hydrogen, and renewable hydrogen. *Int J Hydrogen Energy* 2022;47(58):24584–91.
- [63] Jacob LLC, Janssen MW, Detz Remko J, van der Zwaan B. Country-specific cost projections for renewable hydrogen production through off-grid electricity systems. *Appl Energy* 2022; 309.
- [64] Götz M, et al. Renewable power-to-gas: a technological and economic review. *Renew Energy* 2016;85:1371–90.
- [65] IEA. Technology roadmap hydrogen and fuel cells; 2015.
- [66] Howard RA. Decision analysis: applied decision theory. In: Fourth international conference on operational research. Wiley-Interscience; 1966.
- [67] Howard RA. The foundations of decision analysis revisited. In: Edwards W, Miles R, Winterfeldt Dv, editors *Advances in decision analysis: from foundations to applications*, Cambridge University Press; 2007. p. 32–56.
- [68] Bampaou M, S.H., Kyriakides AS, Panopoulos KD, Seferlis P. Optimizing methanol synthesis combining steelworks off-gases and renewable hydrogen. *Renew Sustain Energy Rev*; 2023. 171(113035).
- [69] Australian-Government, Security of Critical Infrastructure Act 2018, D.o.H. Affairs, Editor. Canberra; 2018.
- [70] Saur G. Wind-To-Hydrogen Project: Electrolyzer Capital Cost Study. National Renewable Energy Laboratory - U.S. Department of Energy; 2008.
- [71] Bertuccioli L, et al. Study on development of water electrolysis in the EU. Fuel Cells and Hydrogen Joint Undertaking; 2014.
- [72] Ainscough C, et al. Hydrogen production cost from PEM electrolysis. US Department of Energy; 2014.
- [73] Element-Energy-Ltd. Hydrogen supply chain evidence base, Department for Business, Energy & Industrial Strategy; 2018.
- [74] TRACTEBEL-ENGINEERING-S.A. CNG for commercialization of small volumes of associated gas. World Bank Group - Energy & Extractives; 2015.
- [75] Hinkley J, HJ, McNaughton R, Edwards J, Lovegrove K. Concentrating solar fuels roadmap – final report. CSIRO: Australia; 2016.
- [76] Niu N, et al. The Effect of LNG Shipping Charter Rates on LNG Prices in Asian Market; 2013; Available from: [https://www.itsi.wa.gov.au/docs/default-source/default-document-library/lng-shipping-charter-rates-on-lng-prices-in-asian-market.pdf?sfvrsn=f1886f1c\\_2](https://www.itsi.wa.gov.au/docs/default-source/default-document-library/lng-shipping-charter-rates-on-lng-prices-in-asian-market.pdf?sfvrsn=f1886f1c_2).
- [77] Amos WA. Costs of Storing and Transporting Hydrogen. National Renewable Energy Laboratory - U.S. Department of Energy; 1998.
- [78] NCE-Maritime-CleanTech, Norwegian future value chains for liquid hydrogen; 2019.
- [79] Deloitte. Australian and Global Hydrogen Demand Growth Scenario Analysis. 2019, COAG Energy Council - National Hydrogen Strategy Taskforce.
- [80] Antwerp Po. Power-to-methanol demonstration project. 2019; Available from: <https://www.co2value.eu/wp-content/uploads/2019/09/6-Port-of-Antwerp.pdf>.
- [81] ISPT. Power to Ammonia - Feasibility study for the value chains and business cases to produce CO<sub>2</sub>-free ammonia suitable for various market applications. Institute for Sustainable Process Technology.
- [82] US-DOE. Potential Roles of Ammonia in a Hydrogen Economy. U.S. Department of Energy; 2006.
- [83] Turton R, et al. Analysis, synthesis and design of chemical processes. Pearson Education; 2008.