



Journal of Applied and Computational Mechanics



Research Paper

Numerical Study of the Dynamic Response of Elevated Steel Conical Tank under Vertical Seismic Excitation - Case Study

Nasser Dine Hadj Djelloul¹, Mohamed Djermane², Noor Sharari³, Saria Abdellali⁴

¹ FIMAS Laboratory, University of Tahri Mohamed Bechar, 08000, Algeria, Email: hadjdjelloul_nasserddine@yahoo.com

² FIMAS Laboratory, University of Tahri Mohamed Bechar, 08000, Algeria, Email: djermcub@yahoo.fr

³ Department of Civil Engineering, University of Technology Sydney, Sydney NSW 2007, Australia, Email: Noor.sharari@student.uts.edu

⁴ FIMAS Laboratory, University of Tahri Mohamed Bechar, 08000, Algeria, Email: saria.abdellali@univ-bechar.dz

Received May 31 2022; Revised August 26 2022; Accepted for publication October 08 2022.

Corresponding author: N.D. Hadj Djelloul (hadjdjelloul_nasserddine@yahoo.com)

© 2022 Published by Shahid Chamran University of Ahvaz

Abstract. Elevated cylindrical and conical steel tanks are widely used to conserve water or chemical liquids. These important structures are required to stay protected and operative at any time. The wall angle inclination of conical tank part, as well as the presence of the vertical earthquake component, can cause damage to this structure and even lead to its failure. The purpose of this study is to examine the effect of wall angle inclination of the tank and the vertical earthquake acceleration component on the nonlinear dynamic stability of the elevated steel conical tanks under seismic excitation. The elevated steel conical tank is simulated utilizing the finite element analysis method using ANSYS software. The fluid-structure interaction is considered using a suitable interface that allows the fluid to apply hydrodynamic pressures on the structure. Three different models, namely Model -A-30°, Model -B-45° and Model -C-60° are investigated; it has been concluded that the impact of inclination of the tank wall significantly affects the nonlinear stability of the elevated steel conical tank. While considering the vertical ground acceleration, inclination plays a significant role in the design of this type of structures. Therefore, it should be appropriately included in the seismic analysis of elevated steel conical tanks to satisfy the safety of the elevated steel conical tank response under seismic loading.

Keywords: Non-Linear dynamic analysis, Fluid-structure interaction, Steel conical tanks, Stability, Vertical acceleration.

1. Introduction

Elevated storage tanks are strategic structures in daily industrial activities. These structures are used in water storage facilities and in the industry for the storage of chemical products. There are different types of tanks having different shapes, for example: cylindrical, conical and spherical. However, the elevated conical tanks are the most constructed ones. Under seismic excitation, the walls of the upper tank and the elevated tank support tower experience additional stresses. These forces can lead to several phenomena, such as buckling of the walls [1].

In terms of seismic analysis, many researchers have studied the dynamic behaviour of elevated tanks. Chandrasekaran and Krishna [2] were the first to use the single degree of freedom model to study the dynamic response of elevated tanks. They found that during an earthquake, the parameter of energy absorption is very important and needs to be taken into consideration when designing the tank's structure. They also observed that the critical case is that of a full tank. Ramiah and Gupta [3] also used a model with one degree of freedom to analyze the dynamic response of elevated tanks on different types of soil.

However, in the late 1950s and early 1960s, Housner [4] enabled practicing engineers to perform seismic response analysis of elevated tanks using the two-mass method. This simplified model is considered for the movement of the liquid relative to the tank and also the movement of the tank relative to the base, whereas, another application of this simplified model in the seismic analysis of elevated tanks has been reported by Sonobe [5].

Furthermore, one of the first analytical methods considering the flexibility of the tank walls was proposed by Veletsos [6]. This method is an extension of the Chopra [7] method which is used in the seismic calculation of gravity dams. Authors concluded that the flexibility of the walls has a great effect on the impulsive component.

Particularly after the damage caused by the earthquake on elevated conical tanks in Belgium in the 1970s, research work was carried out on conical tanks under hydrostatic loading by Vandepitte et al. [8]. Indeed, El Damatty et al. [9] studied the static buckling of conical tanks with geometric imperfections under hydrostatic pressures. A non-linear finite element analysis based on a shell member was used in his work. The numerical results show that the presence of such geometric imperfections led to a 35-40% reduction in the critical load.

Moreover, Leonard et al. [10] evaluated the buckling capacity of an elevated steel tank using the finite element technique. In



this work, the analysis of the buckling modes is made by means of the ABAQUS software to estimate the effects of the stiffener arrangements on the buckling modes.

Eventually, Shenton and Hampton [11] studied the effects of seismic supports on the dynamic response of elevated tanks under seismic excitation without taking into account the sloshing component. The supports are considered as parts of one linear elastic system. The results show that the supports reduced the stress at the base of the elevated tanks. The effect of seismic supports on the dynamic response of elevated tanks was also discussed by Shrimali and Jangid [12]. They studied the response of elevated steel tanks under different earthquakes with fixed bases and isolators at the base, and reached to the conclusion that the shear force due to the impulsive component decreases due to the isolation effect, but the sloshing displacement is increased due to the isolation effect.

In addition to this, Sweedan and El Damatt [13] studied numerically the influence of the vertical component of the earthquake on an elevated conical tank using the equivalent mechanical model. Results show that the seismic force due to the vertical component of earthquakes accounts for about 35% of the forces due to hydrostatic pressure.

Apart from this, Dutta et al. [14] examined the dynamic characteristics of the elevated tanks under the effect of soil-structure interaction. They concluded that consideration of soil-structure interaction in the design of these categories of tanks is very important. In the same subject, Dhamak et al. [15] analyzed the dynamic response of elevated tanks, taking into account soil-structure interaction. In this study, a 3D finite element model was produced using ABAQUS software. The results obtained show that soil-structure interaction analysis must be included in the elevated tanks seismic design.

In recent years, many researchers have studied the dynamic behavior of elevated water tanks under seismic excitation. In [31] a series of experiments has been conducted to study the nonlinear water sloshing of tank in detail with different base-aspect ratios. They concluded that the tanks of large aspect ratio under horizontal excitation, shallow water sloshing response develops the planar standing wave. Kamarroudi et al. [32] investigated the effect of vertical excitation on sloshing of elevated tank. First, an experiment was used to provide of results for validating the FEA modeling, for a second numerical part of the study. It was shown that the proposed Housner model with inclusion of vertical excitations, gives satisfactory results with 10% difference in most cases.

The present work is motivated by the lack of information on the nonlinear dynamic behaviour of elevated conical steel tanks. In the first part of this work is aimed at studying the dynamic nonlinear response of elevated steel tanks with three different angles of inclination of the tank wall namely Model –A-30°, Model –B-45°, and Model –C-60°, under seismic excitation using the finite element method. The second part of this work is dedicated to evaluate the effect of vertical component of the earthquake on the dynamic behaviour of elevated steel conical tanks. This work represents the first study on the response of elevated conical steel tanks with different angles of inclination of the tank wall and under the vertical seismic excitation by modelling the fluid in three dimensions considering the fluid-structure-interaction, flexibility of the walls, the non-linearity of materials, the geometric non-linearity, the non-linearity of the excitation and the sloshing effect.

2. Failure Modes of Steel Tanks

Steel liquid storage tanks involve different modes of damage mechanisms. A wide variety of mechanisms damage are possible, depending on the geometric configuration of the tank, as well as a large number of other factors such as tank material, type of structure, etc. Nevertheless, the characteristics of earthquakes also have a significant influence on tanks seismic response. Assessment of the behaviour of cylindrical steel tanks demonstrates that they are susceptible to buckling under a seismic load; this is due to the hydrodynamic pressures which tend to make them uplift from their functions. This in turn initiates the development of very high compressive stresses which can cause buckling, tilting of the tank or the complete destruction of this sort of structure (Fig. 1). As evidenced by the report on the fragility of metal tanks established by The American Lifelines Alliance claims that the damage to these structures is manifested by buckling [16].

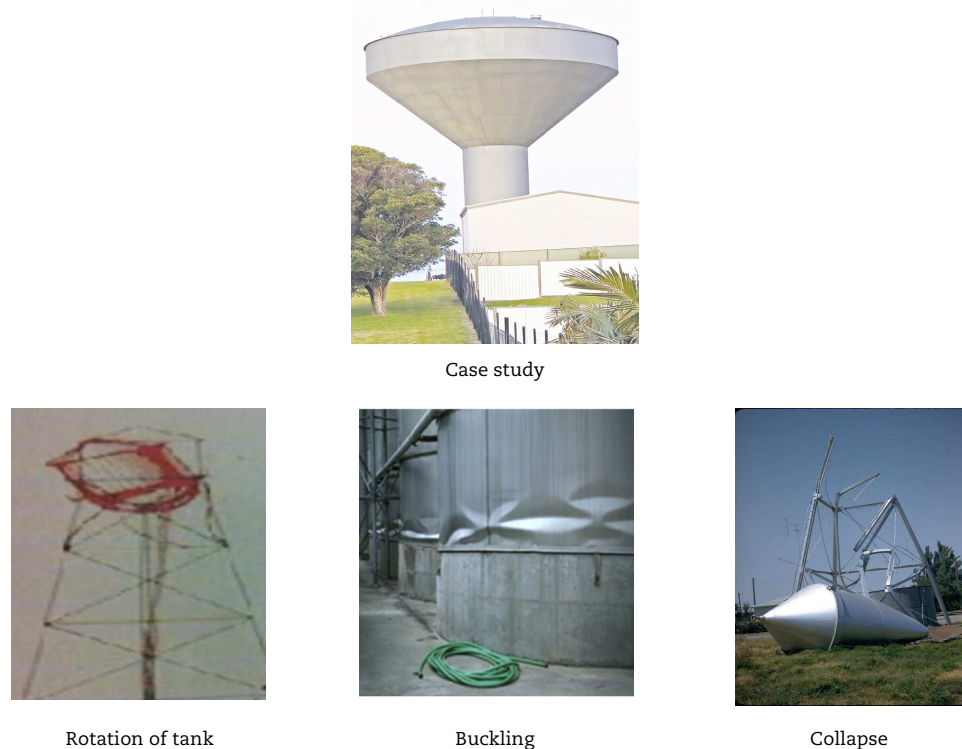

Fig. 1. Examples of the damage done on the steel elevated tank [17, 18].



3. Code Provision

After reviewing the available literature, it is shown that the two American codes: API 650 (American Petroleum Institute) [19] for the design of tanks used in the petroleum industry, and the AWWA (American Water Works Association) [20] for the design of water storage tanks, were the most generally utilized codes for the seismic analysis and computation of steel storage tanks [25].

However, over the last twenty years, other recent codes have seen the day as the European Euro code [21] is on a few focuses considerably more developed than the past two code.

According to the European code, hydrodynamic pressure can be given by the following expressions:

Impulsive rigid pressure:

$$P_i(\xi, \varsigma, \theta, t) = C_c(\xi, \varsigma) \rho_w H \cos(\theta) A_g(t) \tag{1}$$

$$C_c(\xi, \varsigma) = \sum_{n=0}^{\infty} \left(\frac{(-1)^n}{I_1\left(\frac{v_n}{\gamma}\right) v_n^2} \cos(v_n, \varsigma) I_1\left(\frac{v_n \xi}{\gamma}\right) \right) \tag{2}$$

in which $v_n = (2n + 1)\pi / 2$, $\gamma = H / R$.

Impulsive flexible pressure:

$$P_f(\theta, \varsigma, t) = \rho_w H \Psi \sum_{n=1}^{\infty} (d_n \cos \cos(v_n, \varsigma) \cos \cos(\theta) A_f(t)) \tag{3}$$

$$\Psi = \frac{\int_0^1 f(\varsigma) \left[\frac{\rho_s S}{\rho_w H} + \sum_{n=0}^{\infty} (b_n \cos(v_n, \varsigma)) \right] d\varsigma}{\int_0^1 f(\varsigma) \left[\frac{\rho_s S}{\rho_w H} f(\varsigma) + \sum_{n=0}^{\infty} (b_n \cos(v_n, \varsigma)) \right] d\varsigma} \tag{4}$$

$$b_n = 2 \frac{(-1)^n I_1\left(\frac{v_n}{\gamma}\right)}{v_n^2 I_1\left(\frac{v_n}{\gamma}\right)} \tag{5a}$$

$$d_n = 2 \frac{I_1\left(\frac{v_n}{\gamma}\right) \int_0^1 f(\varsigma) \cos(v_n, \varsigma) d\varsigma}{v_n I_1\left(\frac{v_n}{\gamma}\right)} \tag{5b}$$

Convective pressure:

$$P_c = \sum_{n=1}^{\infty} (\Psi_n \cosh \cosh(\lambda_n \gamma \varsigma) J_1(\lambda_n \xi) \cos \cos(\theta) A_n(t)) \tag{6}$$

$$\Psi_n = \frac{2R}{(\lambda_n^2 - 1) J_1(\lambda_n) \cos \cosh(\lambda_n \gamma)} \tag{7}$$

$$\lambda_1 = 1.8112, \lambda_2 = 5.3314, \text{ and } \lambda_3 = 8.5363 \tag{8}$$

$$H_{eq} = \frac{H}{\cos \theta} \tag{9}$$

$$R_{eq} = \frac{(2R + H \tan \theta)}{2 \cos \theta} \tag{10}$$

$$t_{eq} = t \tag{11}$$

The conical shape is the most popular one used for elevated tanks in the world. Unfortunately, the current standards code of training do not provide any data for the designs of the conical tanks for the practicing engineers. The codes are limited to cylindrical and rectangular tanks with the exception of the AWWA code, which gives a methodology based on the calculation of the dimensions of an equivalent cylinder from a conical shape (Fig. 2) [20],



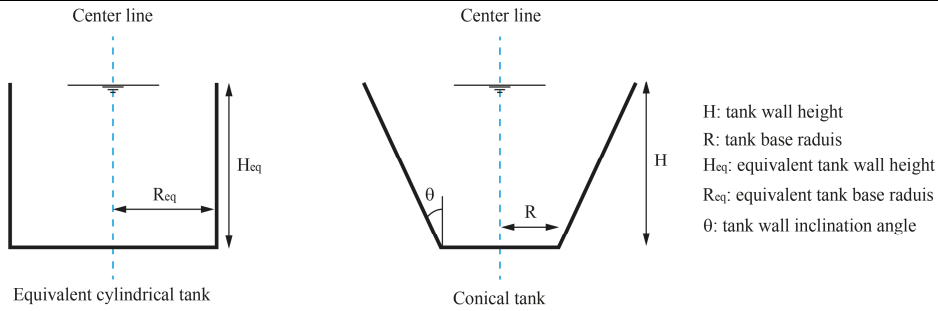

Fig. 2. Conical tank and cylindrical equivalent tank [26].

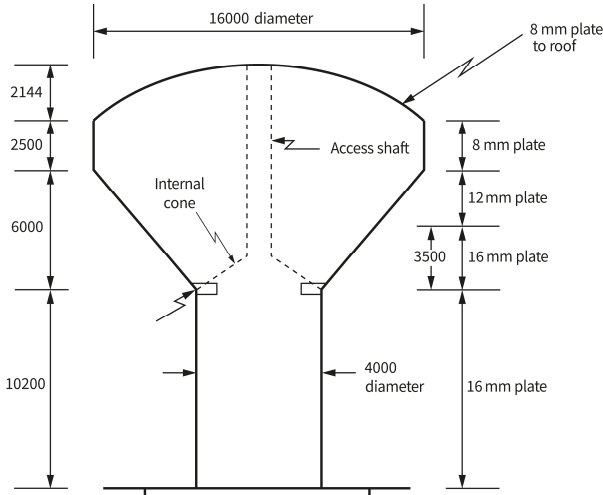

Fig. 3. Elevated steel water storage tank used in this study (Allen et al. [10]).

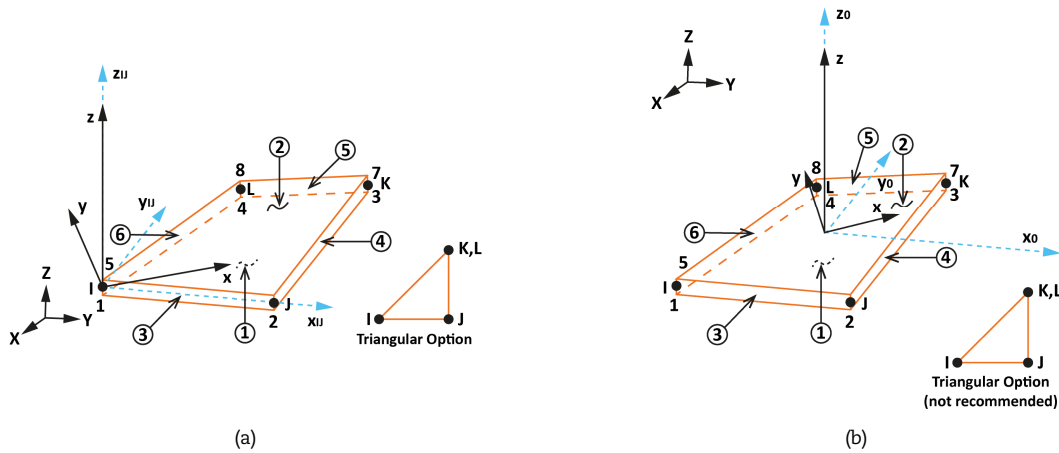

Fig. 4. (a) Shell 63, (b) Shell 181 (The ANSYS Structural Software [22]).

4. Case Study

The example of this study is an elevated real conical steel tank of 1000 m³ capacity, which is located in Kalimna near the entrance to the lakes in Victoria, Australia. The simplified geometry of the model is shown in Fig. 3 [10].

The materials used for the wall and the roof of the elevated tank are elastoplastic, while the material characteristic of the tank as well as of the liquid are presented in Table 1.

Table 1. Mechanical characteristics of tank and liquid [10].

Steel	
Density	7850 kg/m ³
Poisson ratio	0.3
Elasticity modulus	2.06 × 10 ⁵ MPa
Yield stress	2.5 × 10 ² MPa
Tangent modulus	1.45 × 10 ⁴ MPa
Water	
Density	1000 kg/m ³
Bulk modulus	2.0684 × 10 ⁴ MPa
Viscosity	1.123 × 10 ⁻³ N.s/m ²



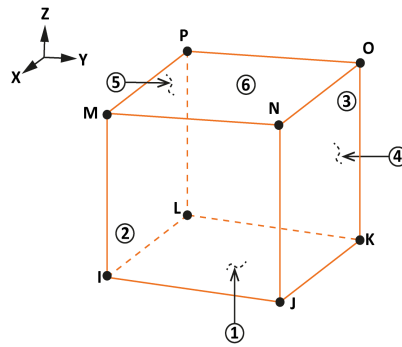

Fig. 5. Fluid 80 element and the nodes degree of freedom (The ANSYS Structural Software [22]).

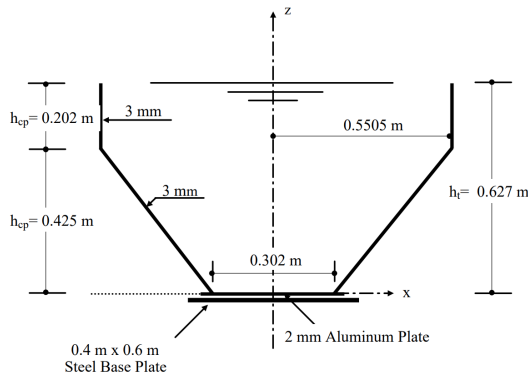

Fig. 6. Geometry of a conical tank (El Damatty et al. [24]).

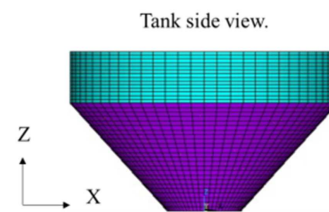

Fig. 7. Finite element model used in the current study.

4.1 Numerical model

In this study, the modelling of the elevated steel tank is performed by means of the ANSYS software using finite element analysis. The tower, tank and roof are modelled using Shell 63 element for modal analysis and Shell 181 element "plastic capacity" for transient analysis. The two elements have six degrees of freedom at each node; translations in the nodal directions x, y and z and rotations around the nodal x, y and z-axes [22, 27].

4.1.1 Fluid

To model the liquid element FLUID80 is used; this element type is used by other researchers as Moslemi et al. [23], Hadj Djelloul et al. [24]. This element is particularly well suited to the calculations of hydrostatic pressures and fluid-structure interactions, acceleration effects, such as sloshing problems. The element is defined by eight nodes having three degrees of freedom at each node: translation in the nodal directions x, y and z.

4.1.2 Fluid structure interaction

The effect of the fluid-structure interaction is considered by coupling the nodes located in the common faces of these two fields. For that, the mesh of each field must ensure that the external nodes of the fluid elements will be located at the same geometrical points as the nodes of the shell elements. This implies that the fluid cannot separate from the wall surface but can apply pressure to the walls [28].

4.2 Validation of the conical tank model with the fluid structure interaction

To validate the numerical model with the fluid-structure interaction; a conical aluminum tank was studied using the finite element method. The results are compared with the experimental values obtained by El Damatty et al. [24], and the numerical values obtained by Moslemi et al. [23]; the geometric and material properties are presented in Table 2 and Fig. 6.

4.2 Results and discussion

4.2.1 Modal analysis results

Table 3 presents the results obtained by the finite element analysis model with those obtained from the experimental work done by El Damatty [25] and another finite element analysis model done by Moslemi et al. [23].

Table 2. Material properties (of the reference model used in validation (El Damatty et al. [24]).

Aluminum shell	Young's modulus	Mass density	Poisson's ratio
	69 GPa	2700 kg/m ³	0.33
Fluid	Mass density	Bulk modulus	Viscosity
	1000 kg/m ³	2.0684 × 10 ⁴ MPa	1.123 × 10 ⁻³ N.S/M ²

Table 3. Free vibration analysis results for the conical tank model [Hz].

	El Damatty et al. [24]	Moslemi et al. [23]	Present work
Convective fundamental mode frequency	0.82	0.84	0.818
Impulsive fundamental mode frequency	43.5	42.36	41.25



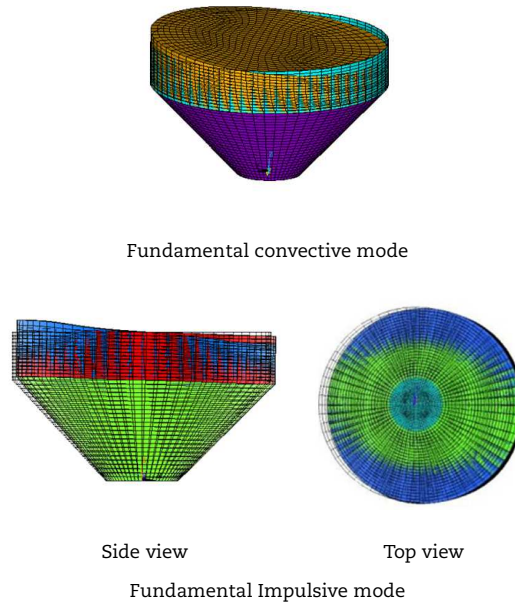

Fig. 8. Deformation of fundamental modes for the conical elevated tank.

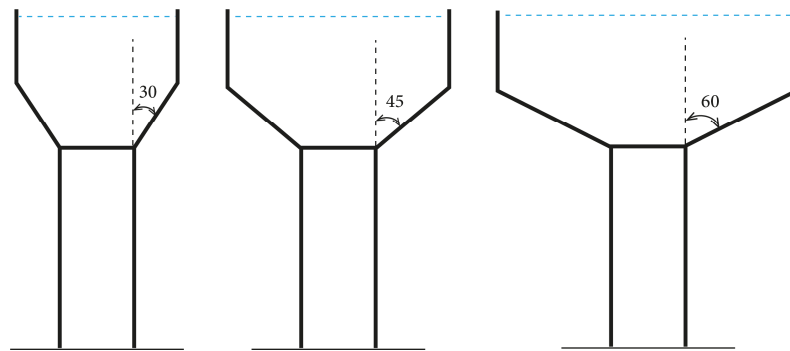

Fig. 9. Elevated tank geometry.

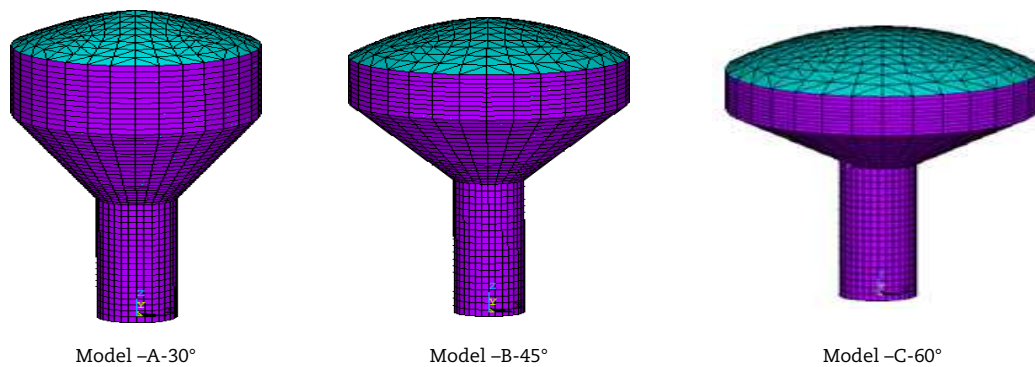

Fig. 10. FE idealization for the elevated steel tanks models.

Examination of the results shows that:

- The finite element model frequencies are in very good agreement with those obtained from the experimental results of El Damatty et al. [24] and the numerical results of Moslemi et al. [23].
- A significant free surface sloshing motion is observed, and no shell vibration is observed during the fundamental convective mode. For the fundamental impulsive mode, the deformation is $\cos(\theta)$ mode and the section of the shell remains circular. Similar results are also reported by El Damatty et al. [24], and Moslemi et al. [23].
- Hence, the numerical model can be used with good precision for this case study.

4.2.2 Elevated tank model

The models of the 1000 m³ real elevated steel conical tank considered in this study are the original model (model B-45) plus two other different models with different cone angles. Models A, C, are created by increasing and decreasing the angle (α) of inclination of the original model (Model A-angle = 30 degrees and model C-60 angle = 60 degrees). The main objective of the first part of the study is to evaluate the effect of the angle of the inclined wall tank on the nonlinear dynamic behaviour of the elevated steel conical tanks.



Table 4. Free vibration analysis results for the elevated conical tank model [Hz].

		Model -A-30		Model -B-45		Model -C-60	
		Frequency	The participating mass percentage	Frequency	The participating mass percentage	Frequency	The participating mass percentage
Numerical model	Convective	0.258	0.375	0.204	0.572	0.163	0.709
	Impulsive	1.07	0.579	1.24	0.379	1.19	0.229
Theoretical model	Convective	/	/	0.21	/	/	/
	Impulsive	/	/	1.17	/	/	/

4.2.2.1 Modal analysis results of the three models

The values of the fundamental frequencies of the three models numerically are grouped in Table 4. The results show that the fundamental convective modes of the liquid for all three cases involve sloshing of the liquid (without any involvement of the shell walls deformation). The fundamental impulsive mode for the three cases is the column type, (Meslmi et al. [23]). It can be observed that the calculated FE results are in reasonable agreement with theoretical model.

By comparing the results of the mass ratios for the three cases, we can notice that, by increasing the angle of inclination of the wall tank relative to the vertical axis the participating mass ratio of the convective mode is increased unlike the impulsive mass ratio. We can also notice that for the cone with a large radius, the convective component is dominant. However, this is not the case for the impulsive component that dominates by decreasing the radius of the tank. This relation is compatible with Housner's theory [4] for the cylinder case [29].

4.2.2.2 Transient analysis

The dynamic transient analysis of the three models considering the effect of the fluid-structure interaction, the flexibility of the walls and the fluid sloshing was carried out. The applied seismic excitation of the San Fernando and El Centro earthquake was used including material plasticity in order to study the stability of the three models, and to perceive the buckling zones of the elevated steel conical tank.

Figures 14 and 15 show the horizontal displacements, phase plane and the deformation corresponding to each model.

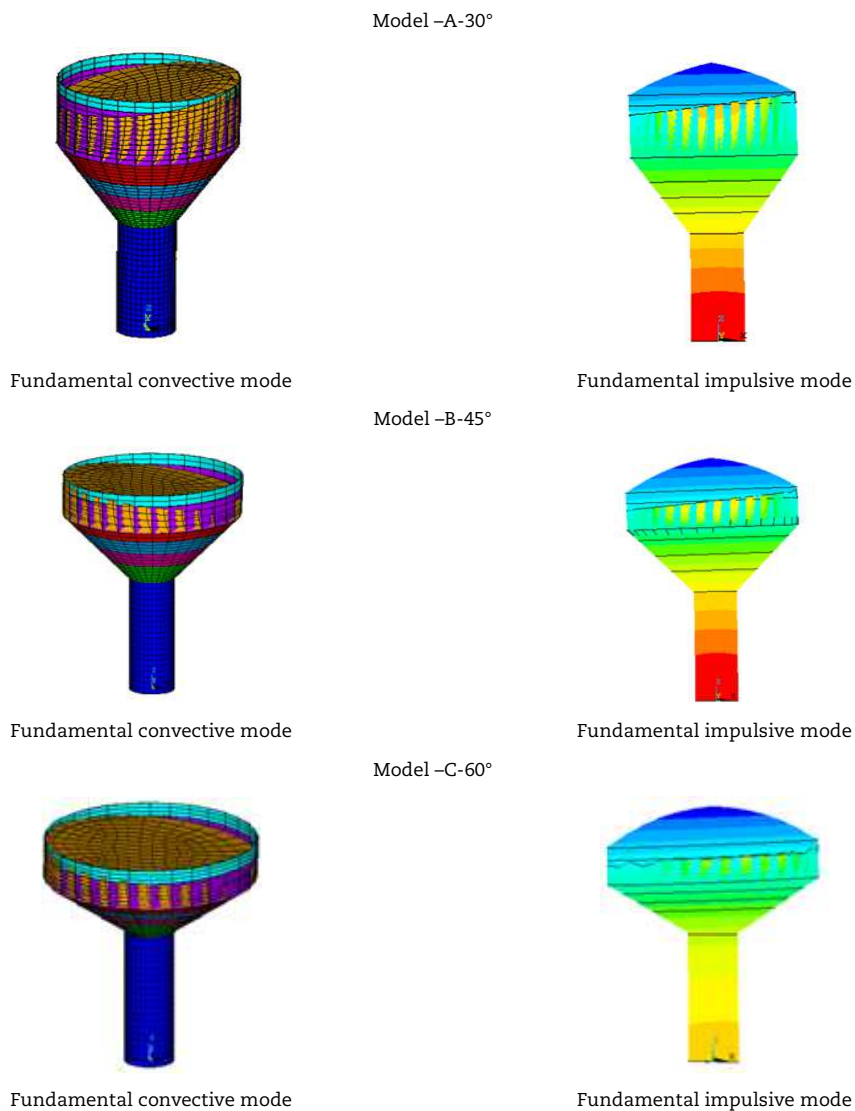

Fig. 11. Modal deformation of the elevated tanks used in this study.



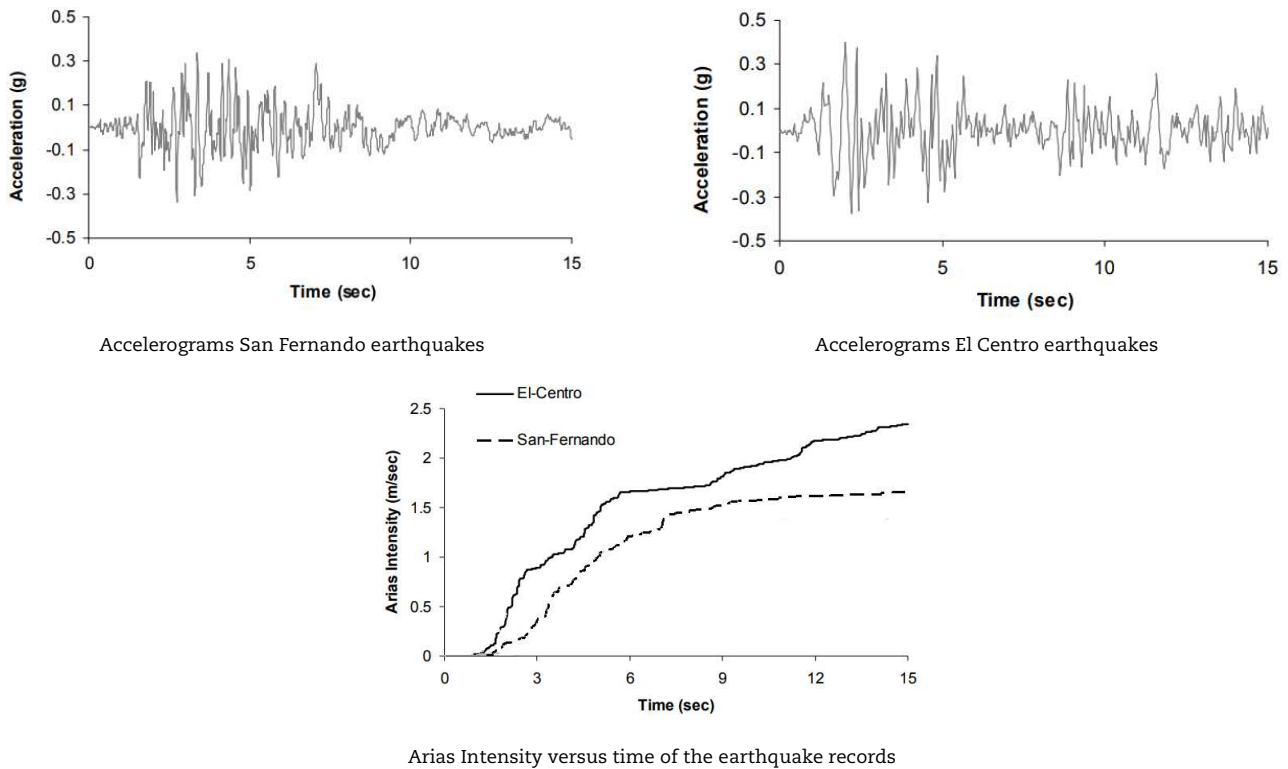

Fig. 12. Characteristic of earthquakes [22].

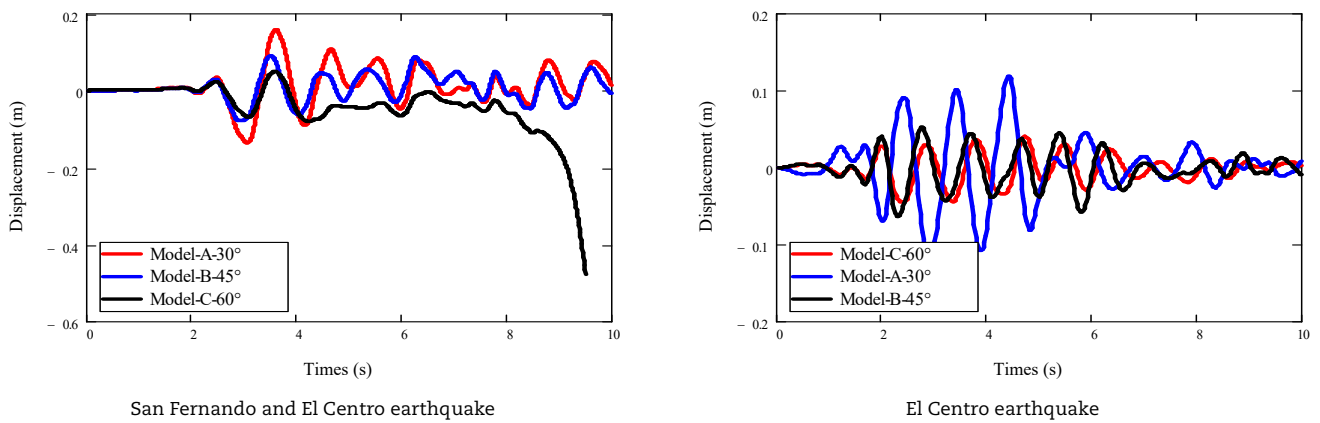

Fig. 13. Time history of horizontal displacement.

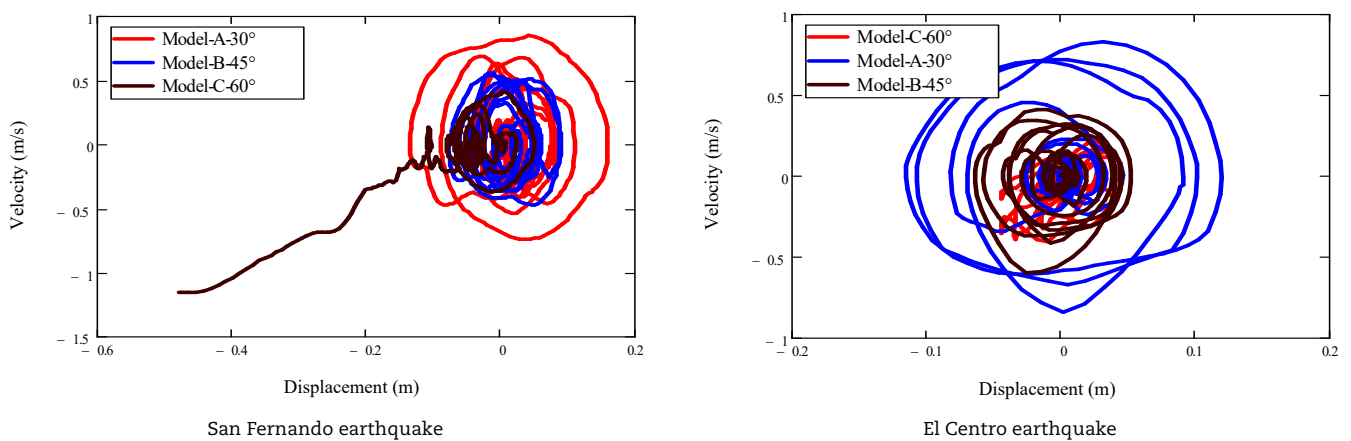

Fig. 14. Phase plane.



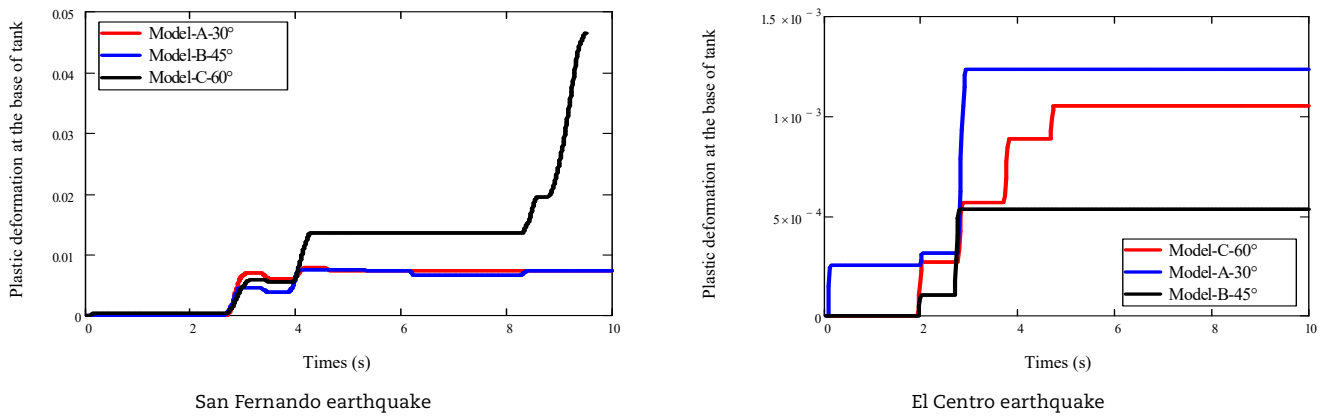

Fig. 15. Plastic strain at the base of tank.

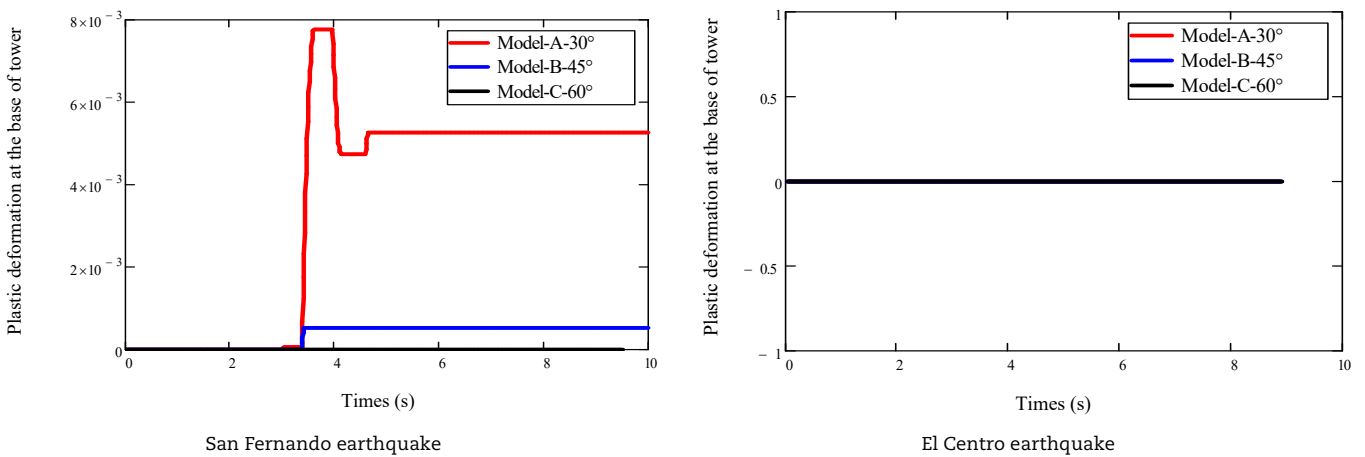

Fig. 16. Plastic strain at the base of the tower.

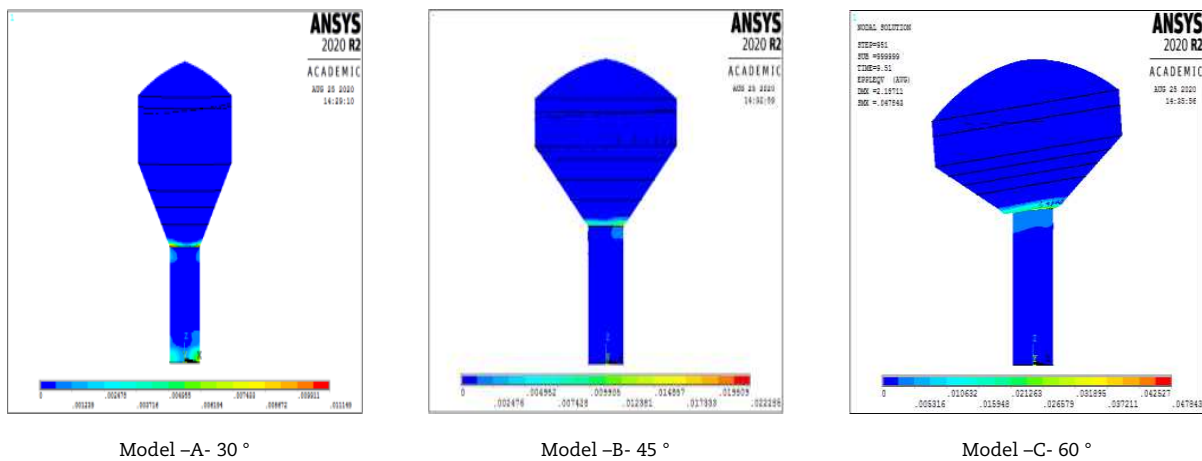

Fig. 17. Plastic strain of shell wall of elevated model tanks (San Fernando earthquake).

Figure 12 clearly shows the influence of the inclination of the wall tank angle on the stability of the structure for (of San Fernando and El Centro earthquake). Note that the displacement values of Model A with an inclination angle of 30 degrees are greater than the values obtained by Model B with an inclination angle of 45 degrees (44.9% difference for San Fernando earthquake) and the displacement values of Model A are greater than the values obtained by Model B (57% difference for El Centro earthquake). A clear jump in displacement is observed in the chronological curves of Model C (inclination angle of the tank 60 degrees), which corresponds to the total instability of this Model under horizontal seismic excitation of San Fernando earthquake.

Figures 13 show the phase plane of each model. Comparing model, A and B, the curve (u, v) relating to the model C presents a significantly different curve (outside the initial oscillations pole); this confirms that the structure with an inclination angle of 60 degrees is unstable.

Figure 14 illustrates the deformation for the three cases. The three tanks deform and keep their deformation even after the end of the seismic excitation. The lower part of the tank shell is subjected to a biaxial stress state combining two vertical and horizontal forces tending to generate the buckling failure (elastoplastic deformation). Regarding the comparison between deformations at the base of the tower of the three models, Figure 15 shows a remarkable difference. It is noticed that Model A – 30° undergoes large deformations compared to the other models.



Figure 15 shows that the maximum deformations are located along the support-tank interface, and this is due to the sudden change in the geometry at this interface for the three case studies. In addition, it is observed that the total destruction happened in the support-tank interface for the Model C - 60°, which is due to the large rotation of the tank. In addition, it is shown that a maximum deformation in Model A-30° is observed in two different points the support-tank interface and at the foot of the tower; on the other hand, in the other cases, the maximum strain is observed at the upper part.

4.2.3 The effect of vertical earthquake excitation

One of the important factors influencing the dynamic behaviour of elevated steel conical tanks, and which has not been considered in previous analyses, is the effect of the vertical excitation of the earthquake. In most codes, the effect of the vertical excitation is considered. In this part, the accelerations are combined using the 30% rules. (Eurocode 8 Part 1 2004) to evaluate the effect of vertical ground acceleration on the dynamic behaviour of model A.

The results obtained clearly show the values of the horizontal displacements, of the combinations H and H+0.3V are significantly higher than the values obtained by the cases 0.3H+V. It is also noted that the effect of the vertical component of the earthquake on the horizontal displacement of the Model-A is insignificant. Indeed, the sloshing results have a slight difference between the sloshing values for the two combinations of H+V and H+0.3V (an increase of 2.83%), unlike the third case 0.3H+V under which the values are reduced by 46%. Considering the 30%, vertical excitation does not have too much influence on the shear force at the base. The 0.3H+V combination produced an underestimation of the shear force.

The 0.3H+V combination has a great influence on the vertical reaction of the Model-A. The vertical reaction values increase by 18.93% compared to the H combination. However, the vertical reaction values remain almost the same for the H+0.3V combination compared to the H combination.

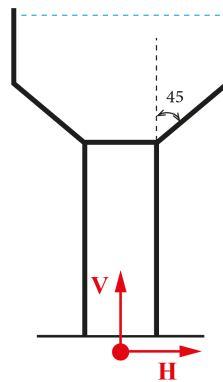

Fig. 18. Two seismic component.

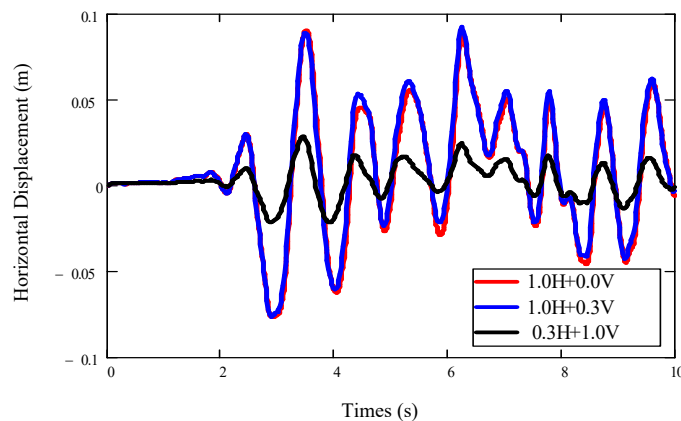

Fig. 19. Time history of horizontal displacement

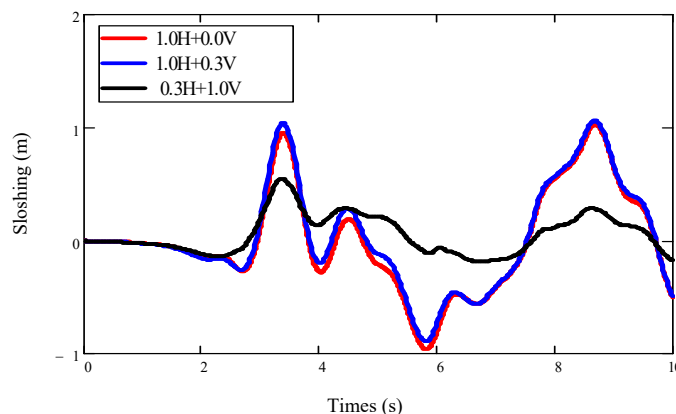

Fig. 20. Time history of sloshing displacement.



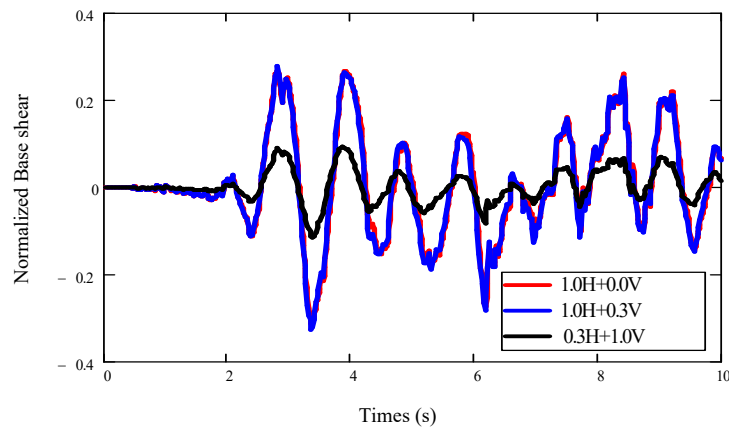

Fig. 21. Time history of base shear

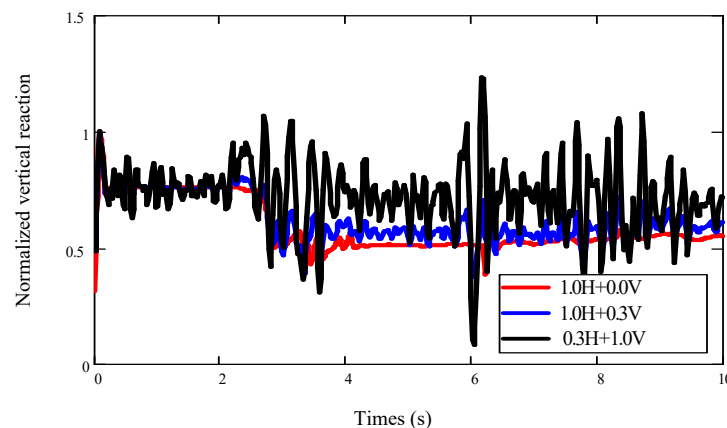

Fig. 22. Time history of normalized vertical reaction.

5. Conclusions

This study investigated the dynamic behaviour of elevated steel conical tanks under the seismic effect using the finite element analysis technique. Considering several factors as fluid-structure interaction, the large amplitude sloshing, the non-linearities of material and geometry, three models having a tilt angle of 30°, 45° and 60° of inclination of the tank wall have been studied. Firstly, the numerical models proposed were validated by comparing the results of the modal analysis obtained with the results obtained by other researchers. In the second part, the effect of the inclination of the tank on the seismic behaviour of elevated conical steel tanks was studied. The following conclusions are found:

- The percentage of the mass participation of the convective part increases with the increase in the angle of inclination of the tank relative to the vertical axis, in contrast to the percentage of the mass participation for the impulsive part.
- The reinforcement of the support-tank part has great importance on the buckling resistance of the wall, which can increase the tank stiffness.
- The angle of inclination of the tank is a key parameter for the seismic design of elevated conical tanks. It was concluded that the design of the tank with an angle of inclination of 45° had better seismic performance under the horizontal seismic component compared to 30- and 60-degrees.
- A study of the seismic behaviour of elevated steel conical tanks was then carried out to investigate the effect of the vertical component of the earthquake on their dynamic behaviour. As the elevated conical steel tank with an angle of inclination of 45 degrees is used, it has been found that the vertical component of the earthquake had no effect on the horizontal displacement and shear force at the base. However, vertical fluid displacement increased by 2.83%. It was also observed that the vertical excitation of earthquakes had a greater effect on the vertical reaction of the elevated tank (an increase of 18.93%). The results obtained also show that the combination of 0.3H+V gives an underestimation of stresses. Therefore, the long-ignored effect of the vertical excitation of the earthquake should be considered appropriately in the seismic analysis of elevated conical steel tanks.

Author Contributions

N.D. Hadj Djelloul developed the numerical model, examined the theory validation, analyzed the empirical results and wrote the manuscript; M. Djermame planned the scheme, initiated the project, and suggested the experiments; N. Sharari developed the finite element model and manuscript proofreading; S. Abdellali developed finite element model and examined the theory validation; All authors discussed the results, reviewed, and approved the final version of the manuscript.

Acknowledgments

This work was supported by FIMAS Laboratory, University of Tahri Mohammed Bechar, Algeria. The authors would also like to thank Dr. Ghomri Tedj for the invaluable help he provided in writing this paper



Conflict of Interest

The authors declared no potential conflicts of interest concerning the research, authorship, and publication of this article.

Funding

This work was supported by FIMAS Laboratory, University of Tahri Mohammed Bechar, Algeria.

Data Availability Statements

The datasets generated and/or analyzed during the current study are available from the corresponding author on reasonable request.

Nomenclature

ξ	Dimensionless coordinate	θ	Cylindrical coordinate
r	Cylindrical coordinate	P_c	convective pressure
R	Tank radius	P_i	Impulsive pressure
t	Times	n	Mode number
λ	Bessel function	H	liquid height
ρ	Liquid density	$A_g(t)$	Acceleration
γ	Geometric slenderness	ς	Dimensionless coordinate

References

- [1] Joshi, S.P., Equivalent mechanical model for horizontal vibration of rigid Intze tanks, *ISET J. Earthq. Technol.*, 37, 2000, 39-47.
- [2] Chandrasekaran, A.R., Krishna J., Water Towers in Seismic Zones, *Proc. of 3rd World Conference on Earthquake Engineering, New Zealand*, 3(4), 1965, 161-171.
- [3] Ramiah, B.K., Rajata Mohana Gupta, D.S., Factors Effecting Seismic Design of Water Towers, *Proc. of the American Society of Civil Engineers, ST4*, 1966, 13-30.
- [4] Housner, G.W., The dynamic behavior of water tanks, *Bull. Seismol. Soc. Amer.*, 53(2), 1963, 381-389.
- [5] Sonobe, Y., Nishikawa, T., Study on the Earthquake Proof Design of Elevated Water Tanks, *Proc. of the 4th World Conference on Earthquake Engineering*, 3(B-4), 1989, 11-24
- [6] Veletsos, A.S., *Seismic Response and Design of Liquid Storage Tanks*, Guidelines for seismic Design of Oil and Gas Pipelines System ZSCE, New York, 1984.
- [7] Chopra, A.K., Earthquake Response of Concrete Gravity Dams, *J. Eng. Mech.*, 96, 1970, 443-454.
- [8] Vandepitte, D., Rathe, J., Verheghe, B., Paridaens, R., Verschaeve, C., Experimental investigation of hydrostatically loaded conical shells and practical evaluation of the buckling load, *Proceedings of State of the Art Colloquium. Universitat Stuttgart, Germany*, 1982.
- [9] El Damatty, A.A., Korol, R.M., Mirza, F.A., Stability of Imperfect Steel Conical Tanks under Hydrostatic Loading, *J. Struct. Eng.*, 123(6), 1997, 703-712.
- [10] Allen, L.R., Hutchinson, G.L., Stevens, L.K., Buckling considerations in the design of elevated steel water tanks, *Thin-Walled Struct.*, 9(1-4), 1990, 389-406.
- [11] Shenton III, H.W., Hampton, F.P., Seismic Response of Isolated Elevated Water Tanks, *J. Struct. Eng.*, 125(9), 1999, 965-976.
- [12] Shriali, M.K., Jangid, R.S., Earthquake response of isolated elevated liquid storage steel tanks, *J. Construct. Steel Res.*, 59(10), 2003, 1267-1288.
- [13] Sweedan, A.M.I., El Damatty, A.A., Equivalent Models of Pure Conical Tanks under Vertical Ground Excitation, *J. Struct. Eng.*, 131(5), 2005, 725-733.
- [14] Dutta, S.C., Dutta, S., Roy, R., Dynamic behavior of R/C elevated tanks with soil-structure interaction, *Eng. Struct.*, 31, 2009, 2617-2629.
- [15] Dhamak, P.S., Rathi, V.R., Ladhane, K.B., Dynamic Response of an Elevated Water Tank, *Int. J. Eng. Res. Tech.*, 3(8), 2014, 1198-1204.
- [16] American Lifelines Alliance, Seismic fragility formulations for water systems, ASCE, 2001. [Mal 06] Malhotra, P.K., Seismic Design of Liquid Storage Tanks, Rapport Technique, American Society of Civil Engineers (ASCE), 2006.
- [17] Soroushnia, S., Tavousi Tafreshi, Sh., Omidinasab, F., Beheshtian, N., Soroushnia, S., Seismic Performance of RC Elevated Water Tanks with Frame Staging and Exhibition Damage Pattern, *Procedia Eng.*, 14, 2011, 3076-3087.
- [18] API Standard 650: Welded Tanks for Oil Storage, ELEVENTH EDITION, 2008.
- [19] American Water Works Association (AWWA), Welded steel tanks for water storage, AWWA D100, 2005.
- [20] European Committee for Standardization (CEN), Eurocode 8: Design of structures for earthquake resistance—Part 4: Silos, tanks and pipelines, 2006.
- [21] The ANSYS Structural Software System.
- [22] Moslemi, M., Ghaemmaghami, A.R., Kianoush, M.R., Parametric based study for design of liquid-filled elevated tanks, *Canad. J. Civil Eng.*, 43(7), 2016, 619-630.
- [23] Hadj Djelloul, N.D., Djermane, M., Sharari, N., Effect of supporting system on dynamic buckling of elevated water tanks: A case study, *Int. J. Safety Security Eng.*, 10(3), 2020, 333-342.
- [24] El Damatty, A.A., Saafan, M.S., Sweedan, A.M.I., Experimental study conducted on a liquid-filled combined conical tank model, *Thin-Walled Struct.*, 43(9), 2005, 1398-1417.
- [25] Djermane, M., Zaoui, D., Labbaci, B., Hammadi, F., Dynamic buckling of steel tanks under seismic excitation: Numerical evaluation of code provisions, *Eng. Struct.*, 70, 2014, 181-196.
- [26] Musa, A., El Damatty, A., Effect of vessel base rotation on the seismic behaviour of conical shaped steel liquid storage tanks, *Eng. Struct.*, 166, 2018, 454-471.
- [27] Zhang, R., Chu, S., Sun, K., Zhang, Z., Wang, H., Effect of the Directional Components of Earthquakes on the Seismic Behavior of an Unanchored Steel Tank, *Appl. Sci.*, 10(16), 2020, 5489.
- [28] Hadj-Djelloul, N.D., Djermane, M., Effect of geometric imperfection on the dynamic of elevated water tanks, *Civil Eng. J.*, 6(1), 2020, 85-97.
- [29] Caprinuzzi, S., Dolšek, M., Seismic performance assessment of non-code-conforming and code-conforming supporting structures of elevated tanks using conventional and risk based decision models, *Eng. Struct.*, 227, 2021, 111469.
- [30] Drosos, J.C., Tsinopoulos, S.V., Karabalis, D.L., Seismic retrofit of spherical liquid storage tanks with energy dissipative devices, *Soil Dyn. Earth. Eng.*, 119, 2019, 158-169.
- [31] Gurusamy, S., Kumar, D., Experimental study on nonlinear sloshing frequency in shallow water tanks under the effects of excitation amplitude and dispersion parameter, *Ocean Eng.*, 213, 2020, 107761.
- [32] Kamarroudi, S.H., Hosseini, M., Hosseini, K., Influence of earthquake vertical excitations on Sloshing-Created P- δ effect in elevated water Tanks: Experimental Validation, numerical simulation and proposing a modification for Housner model, *Eng. Struct.*, 246, 2021, 112995.

ORCID iD

Nasser Dine Hadj Djelloul  <https://orcid.org/0000-0003-3296-7112>



Mohamed Djermane  <https://orcid.org/0000-0002-0066-390X>

Noor Sharari  <https://orcid.org/0000-0002-0436-9329>

Saria Abdellali  <https://orcid.org/0000-0001-7863-3236>



© 2022 Shahid Chamran University of Ahvaz, Ahvaz, Iran. This article is an open access article distributed under the terms and conditions of the Creative Commons Attribution-NonCommercial 4.0 International (CC BY-NC 4.0 license) (<http://creativecommons.org/licenses/by-nc/4.0/>).

How to cite this article: Hadj Djelloul N.D., Djermane M., Sharari N., Abdellali S. Numerical Study of the Dynamic Response of Elevated Steel Conical Tank under Vertical Seismic Excitation - Case Study, *J. Appl. Comput. Mech.*, 9(2), 2023, 445–457. <https://doi.org/10.22055/jacm.2022.40982.3687>

Publisher's Note Shahid Chamran University of Ahvaz remains neutral with regard to jurisdictional claims in published maps and institutional affiliations.

