

# A Heterogeneous Network Management Approach to Wireless Sensor Networks in Personal Healthcare Environments

A thesis submitted by **Karla M. Felix Navarro**  
in fulfilment of the requirements for the award of the degree  
DOCTOR OF PHILOSOPHY  
in Science

May 2008

Faculty of Science  
University of Technology, Sydney

### **Certificate of Authorship/Originality**

*I certify that the work in this thesis has not previously been submitted for a degree nor has it been submitted as part of requirements for a degree.*

*I also certify that the thesis has been written by me. Any help that I have received in my research work and the preparation of the thesis itself has been acknowledged. In addition, I certify that all information sources and literature used are indicated in the thesis.*

*Karla M. Felix Navarro*

## Acknowledgements

**Thanks for the superb help received from my PhD Supervisor** Associate Professor Elaine Lawrence from **the Faculty of Information Technology** and to Associate Professor Don Martin from **the Faculty of Health Sciences from the University of Technology Sydney**, as without their guidance and support this research work would not have crystallised.

**Special thanks to the present and former research assistants, group members and research collaborators of the multicultural mHealth Research Group at the Faculty of Information Technology at UTS for their hard work, team spirit and brilliant contributions**, Professor Elaine Lawrence from Australia, Josep Riudavets from Spain, Marco Messina from Italy, Einstein Lubrin from Canada, Brian Lim from Singapore, Leena Kowser Ganguli from India, Martin Fischer from Koblenz University and Dr. Frank Kargl from Institute of Media Informatics from Ulm University in Germany. Particular thanks must also go to Professor Matt Welsh from the School of Engineering and Applied Sciences at Harvard University and Nicholas Saporoff from ByteSphere Technologies in the USA, to Dr. Steven Mason and the Brain Interface Research Group from the Neil Squire Society in Vancouver and Professor Victor C.M. Leung from the University of British Columbia in Canada for their invaluable collaborations in the accomplishing of the research objectives of this project.

**Thanks for the timely and objective observations of this work through the reviewing and editing of this document,** Associate Professor Elaine Lawrence from University of Technology Sydney, Dr. Agnieszka Bachfischer from The University of Sydney, Dr. Frank Kargl from Ulm University, Professor Brian Garner from Deakin University and to John Colville and Dr. Anne Colville from the University of Technology Sydney.

**Exceptional thanks to my professional and life mentors for being such inspirational and fulfilling guide,** Associate Professor Elaine Lawrence and Ury Szewcow from the University of Technology Sydney, to Rick Leung from the National Research Council of Canada, Juan Carlos Gutiérrez Ayala from the *Universidad Iberoamericana campus León*, M.C. Rodolfo Rodríguez from the *Instituto Tecnológico de Los Mochis* and particularly to my parents *Ing. José Alberto Félix Pajarola* and *Rosalva Navarro Vega* for the endearing life guidance and support and for teaming up with my school teachers to always turn the curiosity of my early years into fascinating science and technology discoveries.

**Thanks to** my parents, to my amazing brother and sisters José Alberto Félix Navarro, Melissa Félix Navarro, Rosalva Félix Navarro, to my brother in law Raúl Figueroa and to my beautiful niece and nephew, Ana Sofia Figueroa Félix and Sebastián Figueroa Félix, who can't wait to grow up a few more years to come to visit me in Australia from Mexico. Special thanks to them and also to the rest of my family members and close family friends who always supported the completion of this research project even through the difficult family times we have had in recent past years.

**Thanks to** my loving and supportive friends from all over the world that I had the fortune to meet through my younger years in Mexico

and later on in my other two homes in Sydney and in Vancouver, they also form part of who I am at this point in time, Mónica Alonso, Margret Hernández, the Soto family, Vanessa Jiménez, the Blanquillos crew, Manuel Medina, Hatice Gunes and the ANZAC gang, Eva Hernández, Anita Deans Boyd, Kimberly Chiswell, the Chiswell family and MAWAI, David Campbell, Claudia Mérida, Tatiana Romero, Rubén Rivera, Cecilia Jamasmie, Makoto Adachi, Kevin Thomas, to the TGIF members, the Divos and friends at the National Research Council of Canada, to all my dear friends from the Soccerinos, Queens Park and Socceros United Intl soccer teams, and at last but not the least, to my supportive colleagues and friends in the Department of Computer Systems and in the Faculty of Information Technology at UTS.

## Publications supporting this research

The following is a list of accepted refereed publications resulting from this thesis.

### **Journals**

Mason S.G., Bashashati A., Fatourechi M., **Felix Navarro K.** and Birch G.E. (2007) A Comprehensive Survey of Brain Interface Technology Designs. *Annals of Biomedical Engineering*, Vol. 35, No. 2, pp 137-169.

Lawrence, E., **Felix Navarro, K.**, Riudavets, J. and Messina, M. (2007) Macroscopic Sensor Networks: Application Issues in the Healthcare Industry, *Journal of Computational Methods in Science and Engineering*,(JCMSE),2007 IOS Press, The Netherlands, Vol 6, Supplement 2/2006, (ISSN 1472-7978).

**Felix Navarro, K.**, Lawrence, E. and Martin D. (2005) Visual Categorization of Brain Computer Interfaces System Classification, *Transactions on Information Science and Applications*, Issue 8, Vol 2, (ISSN 1790-0832).

Riudavets, J., **Felix Navarro, K.**, Lawrence, E., Steele, R. and Messina, M. (2004) Multi Router Traffic Grapher for Body Area Network Surveillance. *WSEAS Transactions on Computers*, Vol 3, Issue 6, Dec., 2004. pp 1856-1862.

**Felix Navarro, K.**, Lawrence, E. and Martin, D.(2004) Applicability of Social Weight Theory to Brain Computer Interfaces, *WSEAS Transactions on Computers*, Vol 3, Issue 6, Dec 2004. pp.1849 – 1855.

## Conferences

Messina, M., Lawrence, E., **Felix Navarro, K.** and Lubrin, E. (2007) Towards Assistive Healthcare: Prototyping Advances In Wireless Sensor Network (Wsn) Systems Integration And Applications, IADIS International Conference e-Society 2007, Lisbon, Portugal, 3-6 July 2007.

Lubrin, E., Lawrence, E, and **Felix Navarro, K.** (2006) Motecare: An Adaptive Smart Ban Health Monitoring System,,The Fourth IASTED International Conference on Biomedical Engineering, Biomed 2006, February 15- 17, 2006, Innsbruck, Austria.

Lubrin, E., Lawrence, E. and **Felix Navarro, K.** (2006) An Architecture for Wearable, Wireless, Smart Biosensors: The MoteCare Prototype, IEEE Proceedings of Mobile Computing and Learning Conference (MCL 2006), Mauritius, April 24 – 28, 2006. \* Best Paper Award\*

Lubrin, E., Lawrence, E., **Felix Navarro, K.** and Zmijewska, A. (2006) Awareness of Wireless Sensor Network Potential in Healthcare Industry: A Second UTAUT Study, Proceedings of the IASTED International Conference on Wireless Sensor Networks (WSN 2006), Banff, Canada, July 3-4, 2006.

**Felix Navarro, K.**, Lawrence, E. and Lubrin, E. (2006) A Network Management Approach To Wireless Sensor Networks In Personal Healthcare Environments, The Fifth IASTED International Conference on Communication Systems and Networks ~CSN 2006~ Palma de Mallorca, Spain August 28 – 30, 2006.

**Felix Navarro, K.**, Lawrence, E. and Martin, D. (2005) Visual Categorization of Brain Computer Interfaces System Classification, 9th WSEAS Circuits,

Systems, Communications and Computers , July 11 -16, 2005, Athens Greece. Published in Journal as well.

Lubrin, E. Lawrence, E. and **Felix Navarro, K.** (2005) Wireless remote healthcare Monitoring with Motes, Fourth International Conference on Mobile Business, July 11- 13, Sydney, Australia.

Riudavets, J., **Felix Navarro, K.**, Lawrence, E., Steele, R. and Messina, M. (2004) Multi Router Traffic Grapher for Body Area Network Surveillance, WSEAS Journal on Applied Informatics and Communications, December 2004.

**Felix Navarro, K.**, Lawrence, E. and Martin, D. (2004) Applicability of Social Weight Theory to Brain Computer Interfaces, WSEAS Journal on Applied Informatics and Communications, December 2004.

Lawrence, E., **Felix Navarro, K.** and Riudavets, J. and Messina, M. (2004) Macroscopic Sensor Networks: Application Issues in the Healthcare Industry, Third International ISCA Conference on Computer Science, Software Engineering, Information technology and eBusiness and Applications (CSITeA 2004), December 27-29, 2004.

**Felix Navarro, K.**, Lawrence, E., Steele, R. and Riudavets, J. (2004) Investigation of the potential of Motes in the Mobile Enterprise, Proceedings of the Third International Conference in M-Business, July 11- 12, 2004, New York, USA.

**Felix Navarro, K.** (2004) Wearable, wireless brain computer interfaces in augmented reality environments, IEEE Proceedings of International Conference on Information Technology: Coding and Computing, 2004 (ITCC 2004), vol.2, pp. 643- 647, 5-7 April 2004.



# Abstract

Many countries are facing problems caused by a rapid surge in numbers of people over sixty-five. This aging population cohort will place a strain on the existing health systems because the elderly are prone to falls, chronic illnesses, dementia and general frailty. At the same time governments are struggling to attract more people into the health systems and there are already shortages of qualified nurses and care givers.

This thesis represents a multi disciplinary approach to trying to solve some of the above issues. In the first instance the researcher has established the validity of the health crisis and then examined ways in which Information Technology could help to alleviate some of the issues. The nascent technology called Wireless Sensor Networks was examined as a way of providing remote health monitoring for the elderly, the infirm and the ill. The researcher postulated that Network Management models and tools that are used to monitor huge networks of computers could be adapted to monitor the health of persons in their own homes, in aged care facilities and hospitals.

Wireless Sensor Network (WNS) Personal Healthcare can monitor such vital signs as a patient's temperature, heart rate and blood oxygen level. WSNs (often referred to as Motes) use wireless transceivers that can do remote sensing. The researcher aimed to assist all stakeholders in the personal healthcare arena to use WSNs to improve monitoring. The researcher provided a solution architecture and framework for

healthcare sensor monitoring systems, based on network management techniques. This architecture generalises to heterogeneous and autonomous data acquisition systems.

Future directions from this research point towards new areas of knowledge from the development or creation of new technologies to support the exponential growth of ubiquitous, just-in-time WSN health informational services and applications such as the preventive and proactive personal care health management and services around it. The affordable and ubiquitous distributed access to remote personal health care technologies in the future could have an important impact in the society, by allowing the individuals to take immediate preventive actions over their overall health condition. These systems could potentially prevent death as well as improve national health budgets by limiting costly medical interventions that could have been avoided by individual, easy-action early prevention.

# Table of Contents

<b>1. Introduction .....</b>	<b>1</b>
1.1 Introduction .....	1
1.2 Overview and the Research Question.....	1
1.2.1 Hypotheses.....	3
1.2.2 Research Purpose.....	3
1.2.3 Research Significance .....	5
1.2.4 Research Rationale .....	6
1.3 Definition of Terms.....	7
1.3.1 Health Monitoring Terms .....	7
1.3.2 Network Management.....	8
1.3.3 Wireless Sensor Network Terms .....	10
1.3.4 Interface Terms .....	11
1.4 Key Contributions .....	11
1.5 Thesis Structure .....	12
1.6 Conclusion .....	17
<b>2. The Growing Health Crisis.....</b>	<b>18</b>
2.1 Introduction .....	18
2.2 Global Healthcare Crisis .....	20
2.3 Aging Population Growth Globally and in the USA.....	21
2.4 Economic Imperatives for Healthcare Monitoring Techniques .....	23
2.5 Increase in Chronic Diseases .....	25
2.6 Other Chronic Diseases – Diabetes and Kidney Diseases .....	26
2.7 Obesity as a Chronic Health Issue .....	28
2.8 State of the Health Care Industry.....	31
2.9 Nursing Shortages.....	32
2.10 Increasing Costs .....	33
2.11 Wireless Monitoring Systems .....	36
2.11.1 MobiHealth Body Area Network (BAN) .....	36
2.11.2 Miniature Heartbeat Monitor.....	37
2.11.3 Digital Plaster.....	38
2.12 Conclusion.....	39

<b>3. Wireless Sensor Networks for Healthcare Monitoring .....</b>	<b>40</b>
3.1 Introduction .....	40
3.2. Technology Overview of Wireless Sensor Networks.....	41
3.2.1 History.....	41
3.2.2 Technical Specifications of the MICA2 and MicaZ Motes .....	44
3.2.3 MCU (Microcontroller) .....	45
3.2.4 The Sensor Board Interface .....	46
3.2.5 RF Transceiver (Radio).....	47
3.2.6 Flash Data Logger Memory .....	49
3.2.7 Default Power Source.....	50
3.2.8 Over- the-air Programmable and Unique ID Identifier .....	52
3.2.9 Radio Spectrum.....	54
3.2.10 Operating System.....	56
3.2.11 Next Generation .....	56
3.3 Technical Advantages and Disadvantages of Wireless Sensor Networks.....	57
3.3.1 Disadvantages: Motes and Security .....	59
3.4. WSN Applications.....	61
3.4.1 Current State of Technology .....	61
3.4.2 Categorization of WSN Applications.....	62
3.4.3 Measurements and Sensors .....	64
3.5 Conclusion .....	66
<b>4. A Network Management Approach to WSN Applications in Personal Healthcare Monitoring .....</b>	<b>68</b>
4.1 Introduction .....	68
4.2 Why Network Management? .....	70
4.3 Network Management Concepts and Techniques .....	71
4.4 Network Management Architectures .....	72
4.5 The OSI/ISO Network Management Model.....	75
4.6 Network Management Organizational Model .....	76
4.7 Adopted Layered NM Organization Models to MoteCare Systems .....	79
4.8 SNMP .....	80
4.9 Network Management Functional Model .....	84
4.9.1 Fault Management.....	85
4.9.2 Performance Management .....	86
4.9.3 Security Management .....	88
4.9.4 Configuration Management.....	90
4.9.5 Accounting Management .....	91
4.9.6 Event Correlation Techniques.....	92
4.10 Implementing Network Management Tools and Techniques in the MoteCare Project .....	93
4.10.1 NM and MoteCare System Requirements.....	94
4.11 Conclusion.....	97

<b>5. Interfaces for the MoteCare Health Monitoring Systems .....</b>	<b>99</b>
5.1 Introduction .....	99
5.2 User Interface Design Overview .....	101
5.3 Interfaces Evaluation Overview .....	101
5.4 Mobile Medical Application Interfaces .....	103
5.4.1 Stages of Growth Framework .....	105
5.4.2 Wearable Interfaces .....	106
5.5 Modification and Extension Approach for Prototyping MoteCare .....	108
5.6 System and Interfacing Requirements .....	109
5.6.1 Functionality of the User Interface: Data .....	111
Collector Description .....	111
5.6.2 Extracted User Interface Characteristics from .....	114
System Requirements .....	114
5.7 Matching the Interface Requirements with Evaluation Results of Available Devices: Thin v Thick Client Interfaces .....	117
5.8 Selected Devices for Prototyping: .....	118
5.9 Conclusion .....	118
<b>6. The MoteCare System: The Core Functional Building of a NM based WSN HealthCare Application .....</b>	<b>120</b>
6.1. Introduction .....	120
6.2 Prototyping .....	123
6.2.1 Open Source and Commodity-Based Technologies .....	125
6.3 Systems Development Methodology .....	127
6.4 Problem Domain .....	128
6.5 The High Level Architecture and Test Bed Setup for the MoteCare and Mobile MoteCare Systems .....	128
6.5.1 The Manager Entity and Management Database (MDB) .....	132
– The MRTG Server .....	132
6.5.2 Problems and Solutions for the MRTG Implementation .....	134
in the MoteCare and Mobile MoteCare Systems .....	134
6.5.3 Three Motes as Clients .....	136
6.5.4 The Enhanced Mobile MoteCare .....	137
6.5.5 Mobile MoteCare Implementation Problems .....	139
6.6 Evaluation and Testing of the MoteCare and Mobile MoteCare Systems .....	143
6.6.1 Mobile Motecare Tesing .....	145
6.7 Results and Discussion .....	146
6.8 Conclusion .....	147
<b>7. The Stargate MoteCare: The Adaptation of a Three-Tier NM Distributed Model .....</b>	<b>149</b>
7.1 Introduction .....	149
7.2 The Stargate MoteCare Description .....	152
7.2.1 Motes Sensor Network .....	153

7.2.2 Stargate Server.....	153
7.2.3 The Manager Entity – The MRTG Server on the.....	160
Stargate MoteCare System .....	160
7.2.4 Smart Monitoring System .....	161
7.3 Evaluation and Testing of the Stargate MoteCare .....	162
7.4 Results and Discussion .....	165
7.5 Conclusion .....	166
<b>8. The Medical MoteCare: The Adaptation of Three-Tier and Agent Server NM Models .....</b>	<b>168</b>
8.1 Introduction .....	168
8.2 Adaptation of Three-Tier and SNMP Proxy NM Organizational Models .....	170
8.3 General Architecture for the Medical MoteCare System .....	171
8.3.1 Motes.....	172
8.3.2 Pulse Oximeters .....	173
8.3.3 Environmental Sensors – Light and Temperature.....	174
8.4 Multiple Variable Event Correlation .....	182
8.5 The Medical MoteCare System Description.....	184
8.6 Scenario Setting .....	186
8.7 Testing .....	187
8.8 Experiments to Simulate Increased Heart Rate .....	188
8.9 Data Fusion with NM Event Correlation .....	191
8.10 Conclusion.....	195
<b>9. Heterogeneous Framework and Conclusions.....</b>	<b>197</b>
9.1 Introduction .....	197
9.2 The NM-WSN Application Development Framework Overview.....	199
9.3 Discussion of Stage I.....	201
9.4 Discussion of Stage II.....	203
9.5 The Layered MoteCare System.....	203
9.5.1 The WSN Layer .....	205
9.5.2 The Middleware Layer .....	206
9.5.3 The NM Core Layer: Network Management Models.....	206
and Techniques .....	206
9.6 The Heterogeneous Framework.....	207
9.7 Analysis and Recommendations .....	208
9.7.1 Core Layer: Network Management Models and Techniques .....	208
9.7.2 Core Layer Recommendations.....	210
9.7.3 Middleware Layer .....	210
9.7.4 WSN Layer .....	211
9.8 Hypotheses Testability Outcomes.....	212
9.9 Conclusions and Future Research Directions .....	214
<b>References.....</b>	<b>216</b>

<b>Appendix A .....</b>	<b>230</b>
<b>Appendix B .....</b>	<b>236</b>

# List of Figures and Tables

## Figures

Figure 1.1 Thesis Development.....	16
Figure 2.1 US Projected Population Figures (US Census Bureau, 2004; Messina, 2004).....	22
Figure 2.2 Twenty Year Australian Population Trends (Historical) (Australian Bureau of Statistics, 2005) .....	23
Figure 2.3 Diabetes Statistics (NIDDK, 2005) .....	27
Figure 2.4 Diabetes Pilot (Diabetes Pilot, 2006) .....	28
Figure 2.5 Obesity Issues (Ogden, 2006) .....	30
Figure 2.6 Mobile-Health Market Projections (Healthservice24, 2007) .....	34
Figure 2.7 Nonin 8000KZ Finger Clip (Konstantas, 2004) .....	37
Figure 2.8 The Digital Plaster Project (Digital Plaster Project, 2007) .....	38
Figure 3.1 Summary of Mote Platforms: Developments of Wireless Sensor Networks (ttdp, 2006).....	43
Figure 3.2 Oximeter Attached to MICA2 Mote (VitalDust, 2006).....	47
Figure 3.3 Block Diagram of the MICA2 (Xbow, 2006) .....	50
Figure 3.4 Photo of a MICA2 (MPR4x0) Without an Antenna (left) and Top and Plan Views Showing the Dimensions and Hole Locations of the MICA2 PCB Without the Battery Pack (right) (MPR400/410/420) .....	53
Figure 3.5 Motes Radio Spectrum (Koubaa, 2005) .....	54
Figure 3.6 ZigBee Stack (ZigBee Alliance, 2006).....	55
Figure 3.7 MicaDot Motes (Crossbow, 2006).....	57
Figure 3.8 Motes and Medical Monitoring (VitalDust, 2006) .....	65
Figure 4.1 OSI Network Management Architecture Model .....	75
Figure 4.2 Two-Tier Network Management Organization Models (Subramanian, 2000).....	78
Figure 4.3 Three-Tier Network Management Organization Models (Subramanian, 2000) .....	79
Figure 4.4 Agent Server Organizational Model (Subramanian, 2000) .....	82



Figure 4.5 Adapted Two-Tier and Three-Tier NM Organizational Models to the Stargate MoteCare and Medical MoteCare Systems .....	83
Figure 4.6 Network Management Functional Model (Fiedler, 2004) .....	84
Figure 4.7 Network Management Systems and a WSN Personal Healthcare Monitoring Systems Intersection.....	95
Figure 5.1 Wireless Application Interfacing Categories mapped to Gibson and Nolan Stages of Growth Framework (Ooi et al, 2005) .....	105
Figure 5.2 High Level MoteCare System Diagram (Lubrin et al, 2006) .....	111
Figure 5.3 MIB510CA Serial Interface Board and Mote Base Station (Crossbow Technology Inc., 2005).....	112
Figure 5.4 Stargate: X-Scale Single Board Computer and Wireless Networking Platform (Crossbow Technology Inc., 2005) .....	113
Figure 6.1 Two-Tier NM Organization Model (Subramanian, 2000) .....	121
Figure 6.2 Agent Server NM Organizational Models (Subramanian, 2000) ..	122
Figure 6.3 Adapted Two-Tier and Agent Server NM Organization Model to MoteCare System .....	122
Figure 6.4 Functional Entities of the MoteCare System .....	126
Figure 6.5 High Level Architecture of the MoteCare System.....	129
Figure 6.6 The MoteCare and Mobile MoteCare Setup (Lubrin et al, 2006)..	130
Figure 6.7 General Layered Communication Overview of the MoteCare System (Messina, 2004) .....	131
Figure 6.8 Graphical Representation of Captured Sensor Data Displayed on MRTG .....	134
Figure 6.9 Config File to run the SerialForwarder/Listen.....	135
Figure 6.10 Reader File .....	136
Figure 6.11 Mobile MoteCare Featuring a PDA Mobile Monitor .....	138
Figure 6.12 The Mobile MoteCare Setup.....	
(Lubrin, Lawrence and Navarro, 2006) .....	139
Figure 6.13 BTS/BTU Connection (Messina, 2004) .....	140
Figure 6.14 Ipaq Expansion Pack (Compaq) .....	141
Figure 6.15 PCMCIA to RS232 Adapter (Triangle Cables) .....	141
Figure 6.16 Sample C# code from PDA.....	142
Figure 7.1 General Layered Communication Overview of the Stargate MoteCare System .....	150
Figure 7.2 The Adopted Three-Tier and Agent Server NM Organization Model to the Stargate MoteCare System .....	151
Figure 7.3 System Overview of the Stargate MoteCare .....	152
Figure 7.4 Stargate: X-Scale Single Board Computer and Wireless Networking Platform (Crossbow Technology Inc., 2005) .....	154

Figure 7.5 C# Sample Code (Lubrin et al, 2005) .....	157
Figure 7.6 Graphical User Interface of The Stargate MoteCare System .....	
(Lubrin et al, 2005).....	157
Figure 7.7 Stargate MoteCare Chowing Graphs (note the cable from the Stargate is plugged into the PDA charger in this photo) .....	158
Figure 7.8 The Stargate MoteCare Showing Interface View of Network Control .....	159
Figure 7.9 Textual and Graphical Representation of Sensor Data .....	
(Lubrin et al, 2006).....	160
Figure 8.1 Adapted Three-Tier NM Organization Model to.....	170
The Medical MoteCare System .....	170
Figure 8.2 System Process Overview for the Medical MoteCare System.....	172
Figure 8.3 MicaZ Mote (www.xbow.com) .....	173
Figure 8.4 The Pulse Oximeter.....	174
Figure 8.5 iReasoning MIB Browser .....	180
Figure 8.6 Overview of SysUpTime Network Monitor ( <a href="http://www.ireasoning.com/sysuptimeoverview.shtml">http://www.ireasoning.com/sysuptimeoverview.shtml</a> ) .....	181
Figure 8.7 SysUpTime Network Monitor .....	182
Figure 8.8 Partial View of Jaguar SX Monitor Exceptions Window .....	183
Figure 8.9 System Overview for the Medical MoteCare System .....	184
Figure 8.10 The Medical MoteCare Showing the Pulse Oximeter, the Stargate Data Acquisition Board, a Light Sensor Mote and the Monitor Unit.....	186
Figure 8.11 Graph from iReasoning MIB Browser .....	189
Figure 8.12 SysUpTime Network Monitor Alarm Triggering .....	190
Figure 8.13 SysUpTime Network Monitor Email System Alert.....	190
Figure 8.14 SysUpTime Network Monitor Email System Alert.....	191
Scenario to Simulate Increased Heart Rate .....	191
Figure 8.15 Jaguar SX WebUI Discovery of the Motes.....	192
Figure 8.16 Jaguar SX WebUI Data Collection of Heartrate and Oxygen Level in Real Time.....	192
Figure 8.17 Jaguar SX WebUI Monitor Exceptions Configuration Page.....	193
Figure 8.18 Jaguar SX Alarm Triggering for Heart Rate & Oxygen Level .....	193
Figure 8.19 Jaguar SX Reports Module for Oxygen Saturation .....	194
Figure 8.20 Mobile Medical MoteCare.....	195
Figure 9.1 MoteCare Project – Stage I .....	199
Figure 9.2 MoteCare Project – Stage II.....	201
Figure 9.3 The Layered MoteCare System .....	204

Figure 9.4 The NM-WSN Application Development Framework .....	207
---	-----

## Tables

Table 1.1 Health Monitoring Terms (Stanford, 2004) .....	7
Table 1.2 Network Management Terms (Network Management Basics, 2006) .....	9
Table 1.3 Summary of Research Stages.....	16
Table 2.1 Factors Influencing Healthcare Crisis .....	20
Table 2.2 Statistics for All Deaths in Australia from Heart Diseases (AIHW, 2002).....	25
Table 2.3 Comparison of Countries' Heart Disease Incidence (AIHW, 2002; Messina, 2004).....	26
Table 2.4 Obesity and Overweight Figures for the USA (Ogden, 2006).....	29
Table 2.5 Summary of Worrying Healthcare Trends for Governments .....	31
(Johnson, 2003; Messina, 2004; Schou, 2001; Catalano, 2002) .....	31
Table 3.1 Development of Wireless Sensor Networks (ttdp, 2006) .....	42
Table 3.2 Mote MICA2 Main Features (Riudavets et al , 2004) .....	44
Table 3.3 Mote MICA2 System Power Consumption Requirements (www.xbow.com) .....	51
Table 3.4 Security and Motes Source (Culler, 2004) .....	60
Table 3.5 Military WSN Applications .....	62
Table 3.6 Environmental Monitoring Applications .....	63
Table 3.7 WSN Applications in Home Automation and Smart Environments ..	63
Table 3.8 Research on Health Monitoring Applications Other than WSNs .....	64
Table 4.1 Components of an SNMP Management System ( <a href="http://tools.ietf.org/html/rfc3411">http://tools.ietf.org/html/rfc3411</a> ).....	81
Table 4.2 Definitions of OSI Functional Model .....	85
(Klerer, 1988; Lewis, 2005) .....	85
Table 4.3 Security Threats to Wireless Sensor Networks (Avancha, 2006)....	89
Table 5.1 Example Applications of Mobile Computing to Primary Health Care (Hameed, 2003) .....	104
Table 5.2 Wearable Computing (Ooi et al, 2005) .....	107
Table 5.3 MoteCare General System Requirements .....	110
Table 6.1 Identified System Requirements.....	128
Table 7.1 Testing Instructions for the Stargate MoteCare System .....	162
Table 8.1 Solutions for Communications .....	175
Table 8.2 Object Identifiers Used for The Medical MoteCare .....	176

Table 8.3 SNMPv3: Features for Network Management .....	177
Table 9.1 Systems Development Methodology .....	
(Felix Navarro et al, 2006) .....	202
Table 9.2 The Main MoteCare Development Components Per Layer .....	205
Table 9.3 Core Layer Element Dissection per MoteCare System .....	209
Table 9.4 MoteCare Middleware layer Recommendations .....	211
Table 9.5 Limitations and Recommendations for the WSN Layer .....	211

# 1. Introduction

*Computers are incredibly fast, accurate, and stupid: humans are incredibly slow, inaccurate and brilliant; together they are powerful beyond imagination (Albert Einstein).*

## 1.1 Introduction

This chapter presents an overview of the research and sets out the research question and its justification and its importance. As this research is of an interdisciplinary nature, certain terms are defined to acquaint readers from different backgrounds with some of the technical and scientific terminology used in this thesis. Finally the structure of the thesis is presented.

## 1.2 Overview and the Research Question

The research objective of this work is to show that accepted and proven Network Management techniques and models are suitable for the development of Wireless Sensor Network (WSN) Personal Healthcare applications such as monitoring a patient's temperature, heart rate and blood oxygen level. WSNs (often referred to as Motes) use wireless transceivers that can do remote sensing. The thesis aims to assist all stakeholders in the personal healthcare arena to use WSNs

to improve the monitoring and, therefore, the health outcomes for the aged, the chronically ill and the infirm. Thus the justification for this research is spread across economic and social imperatives such as helping governments to limit the rising costs for caring for the sick and the elderly whilst not jeopardizing the standard of care. At the same time, the researcher aims to prove that generalizing a solution architecture and framework for healthcare sensor monitoring systems, based on proven network management techniques, will improve the economic and social outcomes. One overarching area of interest of the healthcare industry is in heterogeneous and autonomous data acquisition systems. This thesis contains an overview of a selection of cost effective treatments which optimize patient safety, while minimizing treatment cost and the possibility of malpractice litigation. For example, in the United States cancer specialists are focusing on the need for cost-benefit analysis of cancer treatments and the peculiarities of Healthcare economics (Bowein, 2006). The implications of ageing and healthcare economics for data acquisition, real-time patient progress diagnostics, and for data management are inescapable.

This work describes the evolution of the MoteCare System as a proof of concept of a healthcare monitoring system and reports on the outcomes of testing several prototype systems. As a result of this work a Wireless Healthcare Monitoring framework was developed to guide other researchers in this field.

### 1.2.1 Hypotheses

The issues that were identified from the literature reviews of:

- a) WSNs;
- b) the specific interfaces that connect to the devices (Motes, 2005) in the WSNs;
- c) open source and commercialized network management tools as well as the building of these prototypes;

led to the refinement of the research hypotheses to:

**H.1** That a network management tool can be used to assist in the development of a distributed Personal Healthcare Monitoring System and lead to the development of a generic network management framework for healthcare applications.

**H.2** That such a personal healthcare monitoring system could replace medical monitoring proprietary based systems with less expensive commodity based hardware and open source software.

**H.3** That a network management tool can add intelligence to a health monitoring system by measuring and correlating a number of signals and alerting when certain conditions represent specific undesirable events, or a threat for the patient.

### 1.2.2 Research Purpose

Statistics from countries such as the United States confirm the population growth of elderly and infirm people. The number of Americans aged 65 and older climbed to more than 34.6 million in 1999 compared with 3.1 million in 1900 (Dipert, 2004). Evidence that

this is a global trend is found in the fact that the United States ranks 32<sup>nd</sup> on a list of countries that have growing populations of people 65 and older. This ageing trend is particularly noticeable in developing countries and, overall it is forecast that, between the years 1990 and 2020, the proportion of people aged between 65 – 74 will increase by 74% (Dipert, 2004). The impact of these population changes means that governments and relatives/caregivers will need to spend increasing amounts of money and time to care for this cohort. Wireless sensor networks (Motes) offer some hope here for decreasing the cost of monitoring the elderly and sick in their own or in nursing homes. Motes can be used to monitor such items as temperatures in the environment or on the person, cameras may be linked up to motes to enable remote monitoring and thresholds can be set to ensure that action is taken if a particular limit is reached.

Wireless sensor networks are a relatively new research area so it is important to try to expand the body of knowledge to ensure that the advantages and disadvantages of this technology are understood. Exponential progress is the hallmark of almost all types of information technology and *virtually all technologies are becoming information technologies* (Kurzweil, 2005). The ultimate hope is that these technologies will also improve the quality of life of the aged, the infirm and the chronically ill as well as assist the caregivers, be they family or government workers.

One exciting area for such monitoring is via the use of biosignals (such as brainwaves, heart rate signals, eye movements) as direct interfaces for health monitoring. "Biosignals acquired for controlling computer interfaces can also serve for status monitoring of elderly individuals who wish to live at home but who might occasionally need help" (Stanford, 2004).



### 1.2.3 Research Significance

Healthcare costs are spiralling out of control and governments the world over are trying to rein in costs by examining ways in which Information Technology can assist to lower the expense of monitoring ageing persons as well as persons who have chronic illnesses. As an example, more than 90 million Americans have a chronic illness and 75% of the USA's \$1.4 trillion annual spending is on health care (The Economist, 2005). Figures for the growing numbers of aged persons were provided in the section entitled Research Purpose in Section 1.2. These figures led the researcher to emphasize the importance of making health monitoring systems affordable for more people. It is also expected that extending the mobility capabilities of such health care monitoring systems would potentially improve the quality of life of people affected by infirmity, illness or old age.

The specific objectives of this research were to:

- study the academic and industry-based literature to establish the current situation in this area and analyse the specific areas which need further investigation;
- apply network management techniques to the development of wireless sensor networks health care prototype applications;
- demonstrate that such techniques facilitate the development of WSN applications of a similar nature, such as Personal Health Care applications, which could assist in the care of aged, chronically ill or disabled persons;
- utilize commodity based equipment and open source software to set up prototypes to illustrate proof of concept as far as possible, for example:

- wireless sensor networks with pulse oximeters, accelerometers, barometers, microphones plus light, humidity, and temperature monitors;
  - variety of interfaces such as a Brain Computer Interfaces (working with the BCIs developed by the UTS Faculty of Science as well as working at the Squires Institute in Vancouver Canada during 2003 , Personal Digital Assistants (PDAs) , Mobile phones, cameras as further discussed in Chapter 5;
  - network management protocols and software such as Simple Network Management Protocol (SNMP), Multi Router Traffic Grapher (MRTG) (MRTG, 2007), iReasoning Management Information Base Browser, SysUpTime and JaguarSX (Pavesi, 2005);
  - relational, Open Source and commercialized databases such as MySQL (MySQL, 2007), PostgreSQL (PostgreSQL, 2006) and FireBirdSQL;
- make the system easy to use and maintain;
  - allow for remote, distributed monitoring of aged or disabled persons;
  - develop a framework based on accepted, heterogeneous Network Management (NM) models suitable for the development of WSN Personal Healthcare applications.

#### **1.2.4 Research Rationale**

This research was undertaken in a series of steps which are set out below:

- examination of the literature in a series of specific areas, namely healthcare, network management principles, wireless sensor

networks and suitable interfaces including Brain Computer Interfaces (BCIs) and mobile devices;

- application of common principles from Network Management to the Healthcare environment;
- examination and acceptance or rejection of a variety of interfaces for such a prototype healthcare monitoring system;
- development of an architecture suitable for application to a wireless sensor network healthcare system;
- development of a series of prototypes based on network Management models, with each prototype being developed as the result of testing, evaluation and discussion of its predecessor;
- development of a generic Network Management Framework suitable for application to healthcare monitoring systems;
- analysis of results and conclusion.

### 1.3 Definition of Terms

As this research covers a range of new and developing technical areas as well as health disciplines, the following definitions are provided.

#### 1.3.1 Health Monitoring Terms

Table 1 outlines some of the terms that are useful for health monitoring.

*Table 1.1 Health Monitoring Terms (Stanford, 2004)*

<b>Term</b>	<b>Definition</b>	<b>Comments</b>
Electrocardiogram (ECG)	Electrical record of the heart muscle	Single electrode can track heart rate
Electroencephalogram (EEG)	Electrical record of the brain activity	Require extensive biofeedback training and have limited bandwidth

Electromyogram (EMG)	Electrical potentials arising from muscle movements.	Contractions of muscles may be used to control devices
Electro-oculogram (EOG).	Electro-oculography measures eye movements	Control computer functions with user eye motions
Galvanic Skin Response (GSR)	Skin Conductivity depends on secretions from sweat glands	Greater conductivity is associated with greater stress

### 1.3.2 Network Management

A definition of network management is provided, followed by a table of network management terms in Table 1.2.

**Network management** means different things to different people. In some cases, it involves a solitary network consultant monitoring network activity with an outdated protocol analyser. In other cases, network management involves a distributed database, auto polling of network devices, and high-end workstations generating real-time graphical views of network topology changes and traffic. In general, network management is a service that employs a variety of tools, applications, and devices to assist human network managers in monitoring and maintaining networks (Network Management Basics, 2006).

Network management consists of a number of components, as listed and explained in Table 1.2. The manner in which these will be applied to personal healthcare monitoring will be explained fully in Chapter Four and examples of their applicability will be outlined in the chapters dealing with the prototypes (Chapters 6-9).

Table 1.2 Network Management Terms (*Network Management Basics, 2006*)

Network Management Terms	Explanation
Performance Management	The goal of <i>performance management</i> is to measure and make available various aspects of network performance so that internetwork performance can be maintained at an acceptable level. Examples of performance variables that might be provided include network throughput, user response times, and line utilization.
Configuration Management	The goal of <i>configuration management</i> is to monitor network and system configuration information so that the effects on network operation of various versions of hardware and software elements can be tracked and managed.
Accounting Management	The goal of <i>accounting management</i> is to measure network utilization parameters so that an individual user or a group of users on the network can be regulated appropriately. Such regulation minimises network problems (because network resources can be apportioned based on resource capacities) and maximises the fairness of network access across all users.
Fault Management	The goal of <i>fault management</i> is to detect, log, notify users of, and (to the extent possible) automatically fix network problems to keep the network running effectively.
Security Management	The goal of <i>security management</i> is to control access to network resources according to local guidelines so that the network cannot be sabotaged (intentionally or unintentionally) and sensitive information cannot be accessed by those without appropriate authority.

### 1.3.3 Wireless Sensor Network Terms

Some terms associated with Wireless Sensor Networks are provided below.

A **wireless sensor network** (WSN) is a network made of thousands of microcomputers with onboard sensor boards. The sensor nodes, currently the size of a 35 mm film canister, are self-contained units consisting of a battery, Radio Frequency [RF] adapter, microcontroller, and sensor board. The nodes self-organise their networks, rather than having a pre-programmed network topology. Because of the limitations due to battery life, nodes are built with power conservation in mind, and generally spend large amounts of time in a low-power "sleep" mode or processing the sensor data that has been gathered, for example, temperatures (Network Management Basics, 2006).

Further details will be given in Chapter 3 of this thesis.

**Smartdust** is a network of tiny wireless microelectromechanical sensors (MEMS), robots, or devices, installed with wireless communications that can detect a variety of signals such as light and temperature, to vibrations. The devices are also called *motes* (Motes, 2005) and are intended to eventually be as small as the size of a grain of sand, or even a dust particle. Each device contains sensors, computing circuits, bidirectional wireless communications technology and a power supply. **Motes** are essentially microcomputers that work in conjunction with different sensor boards to process and transmit sensor data. These Motes can form ad-hoc networks whose nodes are capable of connecting seamlessly to each other to enable monitoring over an entire household. Due to the small screen size (form factor) of these devices, their potential can only be realized as networks of Motes (Network Management Basics, 2006).

### 1.3.4 Interface Terms

A **brain-computer interface** (BCI) or **direct neural interface** is a direct technological interface between a brain and a computer, which does not require any motor output from the user. That is, neural impulses in the brain are intercepted by a series of electrodes positioned on the skull and used to control an electronic device. The BCI can translate the signals that the computers can understand, process and convert into actions such as moving a cursor, turning on a light or switching on a television (Ortiz, 2007).

**Personal digital assistants (PDAs or smart phones)** are handheld devices that were originally designed as personal organisers, but became much more versatile over the years. A basic PDA usually includes a clock, date book, address book, task list, memo pad, and a simple calculator. One major advantage of using PDAs is their ability to synchronise data with a PC or home computer. Many PDAs are now mobile phones (smart phones) as well (PDA, 2006).

## 1.4 Key Contributions

The key contributions of this thesis are:

- extensive literature reviews of health statistics, healthcare and remote monitoring systems, network management techniques, the emerging research area of wireless sensor networks and user interfaces such as PDAs, laptops and Brain Computer Interfaces to ensure that the researcher had an exhaustive knowledge of these issues, including their advantages and disadvantages;
- extension of current Frameworks and Models to accommodate Cost-Effectiveness of, and to reward, innovations in Healthcare

Treatments, including innovations in heterogeneous network management using Wireless Sensor systems;

- the development and testing of a series of prototypes to illustrate the applicability of WSNs to healthcare monitoring; The significance of the experimental work is stressed in an emergent (disruptive) technologies context;
- the development of a Generic Network Management Framework to assist in the development of effective healthcare monitoring systems.

## 1.5 Thesis Structure

**Chapter one** sets out the basis for the study. The research questions are outlined and the justification and objectives of the research are set out. The technical terms for a variety of areas such as medical monitoring devices, wireless sensor networks and interface terms are explained. The research methods that were used to accomplish the objectives are set out. Finally the thesis chapter structure is explained.

The next four chapters establish the background to the thesis. **Chapter two** provides a literature review of healthcare issues and outlines why such issues must be addressed. Economic issues are canvassed as increasing healthcare budgets are alarming governments worldwide. Organizational issues of concern to government include the shortage of trained healthcare staff (especially nurses) and the need to look after more and more elderly people either in their homes or in aged care facilities and hospitals. The need to handle vast amounts of paper based information is another factor of concern. Effective electronic data acquisition and the possibility of real-time progress diagnostics are some of the technical issues that need to be addressed. The need for distributed, remote monitoring of the elderly, the infirm and the ill is identified as possible solution to address economic, social,



organizational and technical challenges identified in this chapter. The idea of using commodity based, open source hardware and software is identified as having potential economic and social benefits for healthcare monitoring.

**Chapter three** provides an in depth overview of wireless sensor networks, their history and the technical advantages and disadvantages of WSNs in healthcare environments. WSNs mark the arrival of low cost sensors with wireless network interfaces and, although they are now being deployed in a variety of applications such as military, medical, industrial and domestic networks, they are still classified as in an early stage of development. The challenges that the deployment of such devices face include scalability, design of power conserving protocols, data fusion and data dissemination. This chapter points out the ways in which the author aimed to address the challenges of healthcare monitoring by using innovative network management models and tools.

In **Chapter four** network management techniques and personal health monitoring are explored and the researcher illustrates the linkage between the two – namely why network management tools are suitable for use in the development of personal healthcare applications. The OSI model of network management is described and linked to management of WSNs in a healthcare application. Sections of the Functional and Organizational models are utilized for the design and set up of the proof of concept prototypes which are built and tested during the duration of this thesis.

In **Chapter five** a variety of interfaces for the proposed system are discussed. The author analyses the requirements needed for effective interfaces between the WSNs and the Network Management Tools. The analysis focuses on the use of Nolan's Stages or Growth Theory as well

as Modification and Extension Model for Prototyping. The latter is in keeping with the use of commodity based hardware and open source software requirements for the prototypes. The high level system requirements for the MoteCare proof of concept prototype is presented and explained. Attention is paid to Brain Computer Interfaces (BCIs) as the researcher originally considered that such interfaces would prove to be ideal if connected wirelessly to the interface between the patient and the display. Extensive research and practical experience with BCIs proved otherwise so the researcher concentrated instead on Personal Digital Assistants (PDAs), Smart Phones and laptop computers.

**Chapter six** describes the building and testing of the preliminary MoteCare and Mobile MoteCare systems using environmental sensors such as light and temperature. The architecture is described and the design and building of these two prototypes, which enables the data collection, storage and display of sensed data on the Network Management tool MRTG, is outlined. The Mobile MoteCare system includes the increased remote and mobile monitoring capabilities by implementing a PDA interface in the application. The adaptation of the Functional Network Model and the two tier Organizational model is illustrated in the design of these two prototypes.

In order to meet aligned system requirements, enhancements in the system are performed in the design of the Stargate MoteCare. The system design description and the Three Tier Organizational NM adapted model are presented in the following chapter.

**Chapter seven** describes the building and testing of the Stargate Mote Care. Its main characteristics are the utilization of a Stargate Agent for partial data collection and mote control, the implementation of an alarm system, as well as an improved user interface for higher usability. The Stargate MoteCare enhancements are based on the three tier Organizational Network Management model. The adapted NM

model and the Stargate MoteCare design characteristics are illustrated in this chapter. The building of the Medical MoteCare system which incorporates the use of medical sensors is described in the subsequent chapter eight.

**Chapter eight** comprises the description design, building and testing of the Medical MoteCare system, whose key features include the ability to poll and handle medical data. The use of pulse oximeters for medical monitoring testing purposes, the incorporation of an SNMP agent and the utilization of various proprietary, network management tools are some of the main characteristics of the Medical MoteCare system.

**Chapter nine** describes the development and components of the proposed conceptual and architectural framework; which merges the development of WSN applications in the realm of network management models and techniques to ease time development, increase robustness and scalability of the system. This chapter includes the conclusion for this research and discusses the outcomes. The significance of this research is illustrated in part by the publications which have been itemised in the front section of this thesis. The future research challenges are presented and discussed.

**Appendices A and B** provide the reader with samples of some of the collected data files from the experiments performed on the presented MoteCare systems, as well as with samples of the instructions rendered to the users for testing purposes. Specific requests of data files or testing user instructions can be provided by email request to the author on <Karla@it.uts.edu.au>.

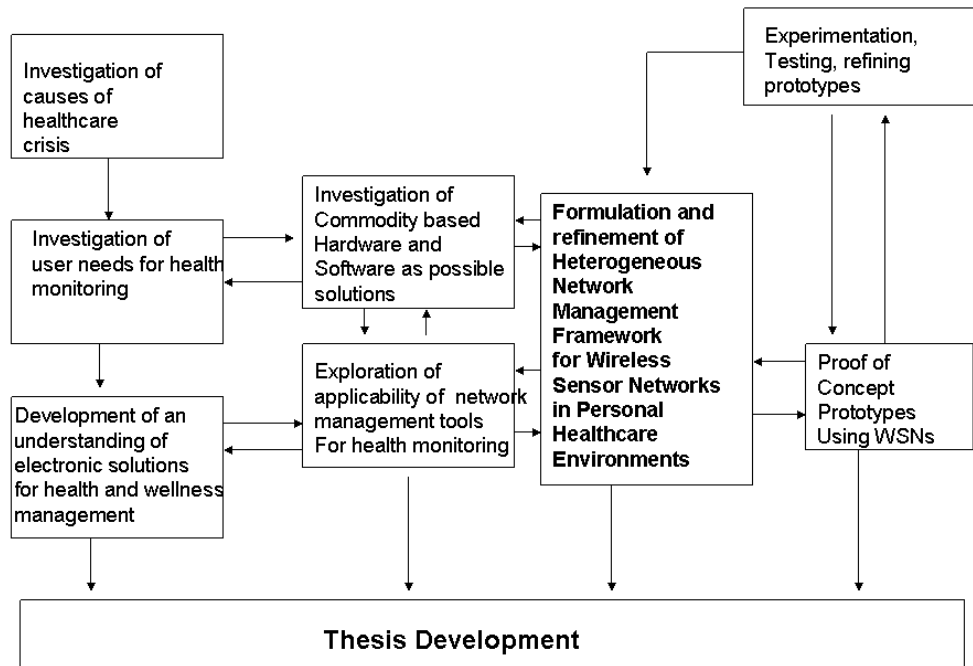

Figure 1.1 Thesis Development

Table 1.3 provides a summary of the research stages, methodology and outputs.

Table 1.3 Summary of Research Stages

Thesis Chapter	Stages	Methodology	Outputs
Chapter 1	Introduction		
Chapters 2 -5	Literature reviews of economic and social healthcare issues; wireless sensor networks, network management techniques and suitable interfaces	Literature analysis Systems Development Theory	Establishment of best practice principles in healthcare monitoring Selection of suitable monitoring devices and interfaces

Chapters 6-8	Building of prototype systems, testing, analysis, improvements	Prototyping Systems Development Theory, Application of Network Models	Enhancements to the proof of concept health monitoring prototypes.
Chapter 9	Framework specification Conclusion	Evaluation	Conceptual framework Key findings

## 1.6 Conclusion

This chapter has set out the research questions and the hypotheses for the research. It has described the rationale behind the research and outlined the way in which the researcher has undertaken the research. The following chapter is the first of a set of literature review chapters that are important for the grounding of this research. It covers the growing health crisis that inspired the researcher to devise innovative ways to assist, using information and communication technologies – in this case wireless sensor networks for remote monitoring of the old, the infirm and the chronically disabled.

## 2. The Growing Health Crisis

*In the 12 months to 30 June 2007, the number of people aged 65 years and over in Australia increased by 72,000 people representing a 2.7% increase. The proportion of the population aged 65 years and over increased from 10.7% to 13.1% between 30 June 1987 and 30 June 2007 (Australian Bureau of Statistics, 2007).*

### 2.1 Introduction

In this chapter the growing global crisis in healthcare is discussed as this phenomenon provides the underpinning for the research. The healthcare crisis is explained and reasons for it are set out. This, in turn, leads to the search for solutions to try to alleviate the problems.

Gururajan et al (2005) state that the crisis in healthcare in both developing and developed countries is a result of:

- the increases in the percentage of older people in the populations;
- increases in the incidence of chronic disease;
- advances in medical technology and pharmaceuticals which leads to longevity;
- increases in the percentage of Gross Domestic Product (GDP) consumed by health and aged care;

- moves towards extending the independence of older people and encouraging more care to be delivered in the home and in the community.

As stated in Chapter 1, one of the goals of this research is to demonstrate the use of technology to develop a smart health monitoring system that has the potential to support elderly or chronically ill persons at their homes and to delay or avoid moves to institutional care (Gururajan et al, 2005). The author aims to demonstrate that this research could provide significant cost reductions to governments, healthcare providers and individuals as a result of the remote monitoring capability of the prototype MoteCare system as well as from using non-proprietary hardware and open source software. Some added benefits include prevention and early detection of the onset of disease or disability, when treatment is often cheaper and more effective (Gururajan et al., 2005). Warren's view (2006) is that patients should be involved in certain activities such as contributing to monitoring and participating in lifestyle improvements.

The next section deals with factors influencing the global healthcare crisis and provides statistics on the growth of the aging population, globally, as well as in the United States and in Australia. The author then discusses the economic imperative for improving healthcare monitoring techniques. The effects of the growth of chronic illnesses, specifically diseases such as diabetes, heart and kidney problems and the growing obesity problem, on a population's health status are outlined. When examining the state of the healthcare industry, the researcher reports on the crisis in the supply of qualified nurses and other health care personnel and the exponential growth of costs associated with healthcare in our society. The literature review on the Healthcare crisis concludes with an overview of other wireless

healthcare monitoring systems that are currently in place, in order to better understand where the MoteCare prototype is situated.

## 2.2 Global Healthcare Crisis

The following section deals with the growing healthcare crisis which is a feature of both developing and developed countries. The most important aspects of this crisis are set out in Table 2.1.

*Table 2.1 Factors Influencing Healthcare Crisis*

Factor	Details
Growth in the number of chronically ill/disabled persons	Millions of dollars are spent by the governments of different nations trying to reincorporate into the society thousands of people with severe disabilities. The following figures from the United States illustrate the magnitude of the problem. Approximately 200 000 cases of spinal cord injuries – growing at a rate of 11 000 new cases per year. Of these new cases 56% are in the 16 – 30 age group and the recovery rate is 0.7% (Black, 2006).
Obesity rates	It is estimated that 119 million Americans or 65% are either overweight or obese. (Medicalnewstoday, 2004).
Number of people who die from medical errors	<b>Figures for the United States:</b> Approximately 2,000 deaths/year from unnecessary surgery; 7000 deaths/year from medication errors in hospitals; 20,000 deaths/year from other errors in hospitals; 80,000 deaths/year from infections in hospitals; 106,000 deaths/year from non-error, adverse effects of medications. This gives a total of up to 225,000 deaths per year in the US from iatrogenic (when a patient dies as a direct result of treatments by a physician) causes. Such deaths, which are now ranked as the #3 killer in the United States, could result from misdiagnosis or adverse drug reactions for example (Starfield, July 26th, 2000).



<p>Nursing shortage</p>	<p><b>In Australia between 1986 and 2001</b>  there was a 22% decrease in nursing workers employed in aged care, and an 8% decrease in nursing workers employed in hospitals (Australian Social Trends, 2005).  In the United States, more than one million new and replacement nurses will be needed by 2012. For the first time, the U.S. Department of Labor has identified Registered Nursing as the top occupation in terms of job growth through the year 2012. (Monthly Labor Review, 2004).</p>
<p>Spread of the population</p>	<p>People no longer live close to their relatives</p>
<p>Medical people are often not early adopters of Information and Communication Technology</p>	<p>Canadian eHealth thought leaders and key decision makers cited *slow* *adoption* of eHealth applications by busy healthcare providers as a major impediment to progress. A survey of physicians and nurses who use computers in their day-to-day work found that a significant majority (more than 90%) felt that computers not only improved their productivity but also enhanced patient safety (Branhamgroup, 2006)</p>

### 2.3 Aging Population Growth Globally and in the USA

Newman (2003) predicted that in less than a decade after the first “baby boomers” reach retirement age, the elderly population will, for the first time, outnumber the young (Newman, 2003). The worldwide population of people over the age of 65 is expected to more than double from 375 million in 1990 to 761 million by 2025 (Dishman, 2004).

In many countries, the ratio of workers to retirees will drop to 2:1, which will profoundly affect national economic and business productivity. The US Congress already over-burdened with an annual healthcare bill of more than \$1.5 trillion, fears that the healthcare system will be unable to deal with the increase of potential patients. It becomes apparent from such figures that alternative methods of healthcare must be found to help resolve the growing crisis.

Technologies for healthcare monitoring present one avenue of promising research and the author’s use of Wireless Sensor Networks (WSNs) and network management tools to help address the situation are further explained in chapters three and four of this thesis.

The following figures illustrate the changes in the distribution of the various age groups in the US for 2004 and (projected) for 2020. The growth in the population of the other 55s gives an indication of projected increase in people requiring healthcare as they age.

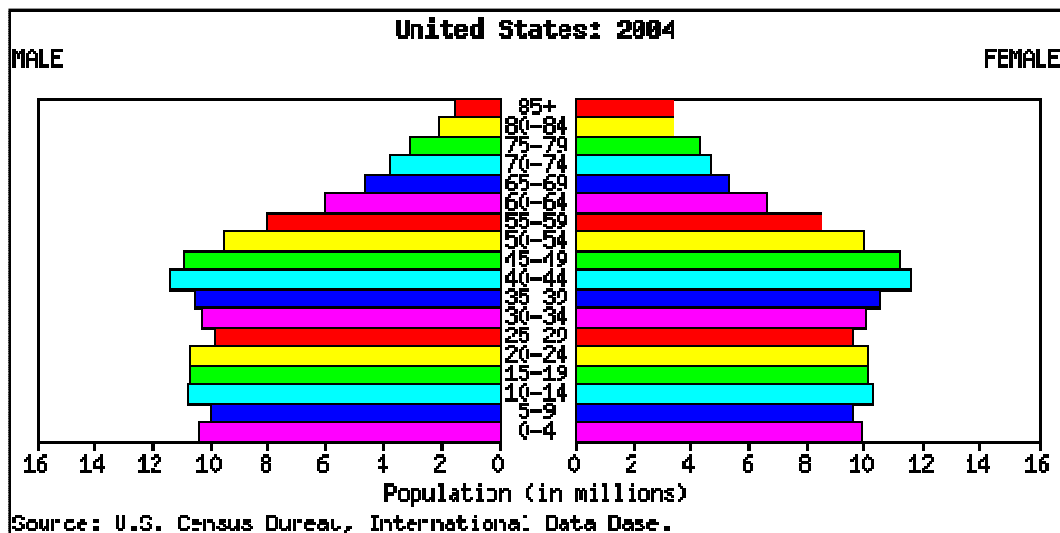
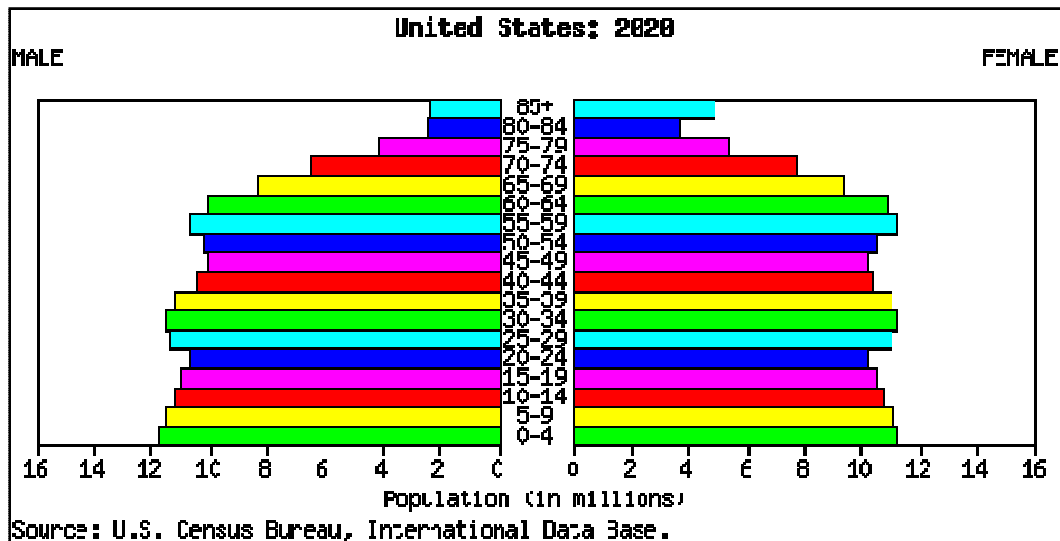

Figure 2.1 US Projected Population Figures (US Census Bureau, 2004; Messina, 2004)

The figures showing the Australian trends are found in Figure 2.2 below.

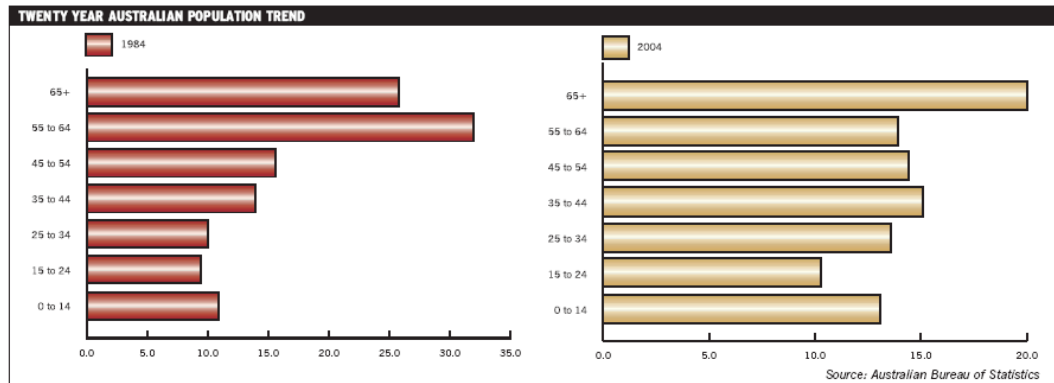

Figure 2.2 Twenty Year Australian Population Trends (Historical)  
(Australian Bureau of Statistics, 2005)

## 2.4 Economic Imperatives for Healthcare Monitoring Techniques

The Australian Bureau of Statistics stated that in 1998, most people aged 65 years or more lived in private dwellings (91%) and 6% lived in hostels or nursing homes (Australian Bureau of Statistics, 1999). The cost of caring for the increasing numbers of aged persons in private dwellings, nursing homes or hospitals will be a huge challenge for the government. For those seniors who prefer to live independently in their own homes, constant remote monitoring is essential to provide adequate care as there is an increased risk of falls, strokes and other health problems which could prove life threatening (Australian Bureau of Statistics, 1999).

Furthermore the Australian Bureau of Statistics reported that in 2002, nearly 13 000 people aged 65 and older died because of fall-related injuries (Australian Bureau of Statistics, 2002). More than 60% of people who die from falls are 75 years old and older (CDC, 2005).

The New England Journal of Medicine (NEJM, 2004) is quoted as reporting that the chances of surviving a fall, heart attack or stroke are six times greater if a senior (over 65 years old) gets help within an hour. Attribution style (Gururajan et al, 2005) stated that most healthcare information is both time and life critical, so it must be captured and/or delivered whenever and wherever needed. Thus in the case of the elderly falling, suffering from a stroke or heart attack must be attended to quickly by a health care worker quickly if they are to survive the trauma (Gururajan et al, 2005).

The Australian Institute for Health and Welfare (AIHW, 2006) have estimated that the total health and welfare expenditure for dementia in 2003 at \$1.4 billion, with the majority in the residential aged care sector where \$993 million is attributed to dementia. Furthermore as reported by the Head of the AIHW's Ageing and Aged Care Unit,

*'People with dementia use a substantial amount of health and aged care services - for example in 2003 they used 1.4 million hospital patient days and 24.7 million residential aged care bed-days. They also require a significant amount of time and help from their careers and many careers experience distress associated with the behavioral and psychological symptoms of dementia' (AIHW, 2006).*

Systems for remote monitoring by devices as exemplified by the MoteCare prototypes of such patients could help ease the economic impost of caring for dementia sufferers.

## 2.5 Increase in Chronic Diseases

Heart failure in western countries has increased in incidence, prevalence and mortality over the past two decades because of the ageing population (McMurray, 2002). Cardiovascular disease (heart, stroke and blood vessel disease) is a major health and economic burden throughout the world, especially in developed countries. Table 2.2 shows the statistics for all death in Australia from heart diseases in 2002 the latest available (viewed on 19 April 2006).

*Table 2.2 Statistics for All Deaths in Australia from Heart Diseases (AIHW, 2002)*

<b>Persons</b>	<b>Age Groups</b>	<b>Total Population</b>	<b>Total Number with heart failure</b>	<b>Death rate per 100 000</b>
Male	65-74	648 954	14426	2223.0
Female	65-74	688 258	8803	1279.0
Total Persons	65-74	1 337 212	23229	1737.1
Male	75-84	370 677	22463	6060.0
Female	75-84	506 202	19963	3943.7
Total persons	75-84	876 879	42426	4838.3

The situation in the rest of the world is similar, with, for instance, a prevalence of symptomatic heart failure in the general population ranging from 0.4 percent to 2.0 percent in Europe (Maisel, 2002).

It is estimated that coronary heart disease will become the single leading public health problem for the world by 2020 (AIHW, 2002; (Messina, 2004).

Table 2.3 Comparison of Countries' Heart Disease Incidence (AIHW, 2002; Messina, 2004)

Countries with Highest Incidence of Heart Disease	Countries with lowest incidence of Heart Disease
1. Russia	1. Japan
2. Ukraine	2. France
3. Romania	3. Canada
4. Hungary	
5. Poland	

The social and economic cost of caring for people with such diseases could be partly addressed by the use of the health monitoring prototypes, namely MoteCare, Mobile MoteCare, Stargate MoteCare and Medical MoteCare, which have been developed by the author and which are described in detail in Chapters 6 – 8 of this thesis.

## 2.6 Other Chronic Diseases – Diabetes and Kidney Diseases

According to the American National Institute of Diabetes and Digestive and Kidney Diseases (NIDDK, 2006), diabetes is a debilitating disease that affects an estimated 20.8 million people in the U.S.—over 7 percent of the total population—and is the sixth leading cause of death. In fact negative health outcome from diabetes include:

- lowering of average life expectancy by up to 15 years;
- increasing cardiovascular disease risk two-to-fourfold;
- being the leading cause of kidney failure, lower limb amputations, and adult onset blindness.

The estimated total financial cost for diabetes in the U.S. in 2002—including costs of medical care, disability, and premature death—was \$132 billion. Effective therapy can prevent or delay these complications, but approximately one third of Americans with diabetes are undiagnosed. Figure 2.3 illustrates these statistics.

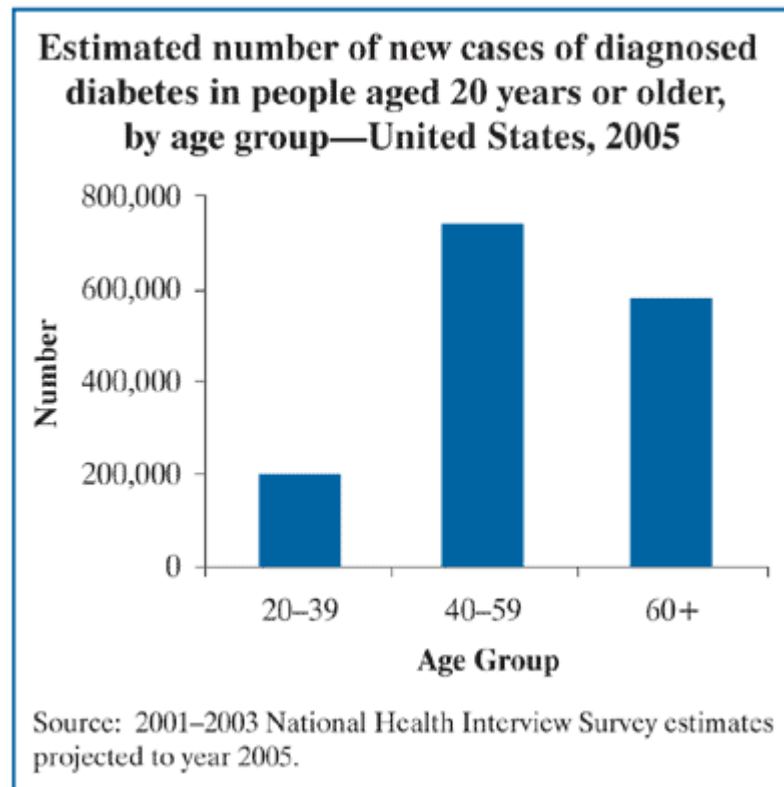

Figure 2.3 Diabetes Statistics (NIDDK, 2005)

Proprietary monitoring technologies for people suffering from diabetes and kidney diseases have been developed, such as the Diabetes Pilot (see Figure 2.4) which records glucose measurements, insulin and other medicine, meals, exercise, blood pressure and test results (Diabetes Pilot, 2006).

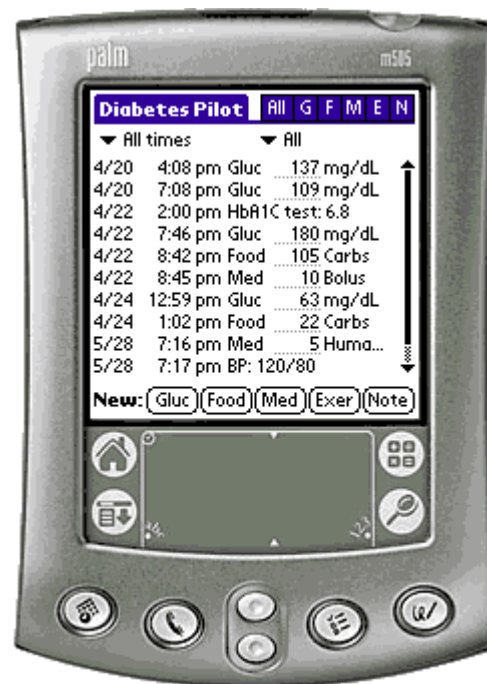

Figure 2.4 Diabetes Pilot (Diabetes Pilot, 2006)

In the MoteCare prototype system proposed and developed by the author, non-proprietary or commodity based components have been used not only to lower the cost of the monitoring of persons who require such surveillance but also to allow the monitoring of environmental factors that might impinge on the health of the person. As an example, the temperature in the patient's room may have an impact on the person's body temperature which, in turn, may indicate a worsening of a chronic condition.

## 2.7 Obesity as a Chronic Health Issue

Ogden et al (2006) provide the latest estimates of overweight children and adolescents and obesity among adults (Ogden, 2006). The estimates are based on measured values of weight and height from the National Health and Nutrition Examination Survey (NHANES), which is conducted by the Center for Disease Control's (CDC, 2005) National Center for Health Statistics. The definitions of overweight and obesity are based on body mass index (BMI, weight in kilograms divided by



the square of height in meters). Among children and adolescents, overweight is defined as at or above the 95th percentile of the sex-specific BMI for age growth charts. Among adults, obesity is defined as a BMI over 30 and extreme obesity is defined as a BMI over 40.

The USA figures are outlined Table 2.4 below.

*Table 2.4 Obesity and Overweight Figures for the USA (Ogden, 2006)*

<b>2003 - 2004</b>	<b>1999 - 2004</b>
17% of 2-19 year olds overweight	Prevalence of overweight girls rose from 13.8% in 1999 to 16% in 2004
32.2% of adults obese	Prevalence of overweight boys increased from 14% to 18.2% in 2004
5% adults extremely obese	Obesity in men increased from 27.5% to 31.1%
	No change in obesity among women – 33.4% in 1999 to 33.2% in 2004

Figure 2.5 below illustrates some of the negative health outcomes from obesity. Although the United States has the highest prevalence of obesity among the developed nations, it is not alone in terms of trends. Increases in the prevalence of overweight and obesity among children and adults have been observed throughout the world (Ogden, 2006).

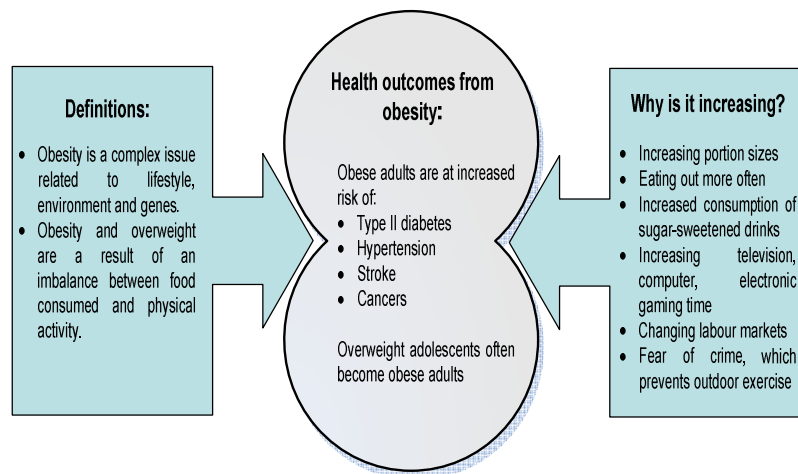

Figure 2.5 Obesity Issues (Ogden, 2006)

The above indicates that there is need for a change in lifestyle and this change can be assisted by the use of innovative, non-invasive and portable health systems. For the chronically ill and aged, the use of remote monitoring has added benefits as it:

- will allow them to remain in situ;
- will alleviate the worry of relatives who are not able to be close to their elderly and infirm loved ones;
- should cut down on the spiralling costs of healthcare for all countries.

The last mentioned issue is expanded in the following section.

## 2.8 State of the Health Care Industry

According to Johnson et al the three primary issues burdening the healthcare industry, particularly in the United States are (Johnson, 2003):

- medical errors;
- nursing shortage with increasing consumers;
- increasing costs.

The quality of care provided by the healthcare organizations around the developed countries has been systematically eroded by these factors (Messina, 2004). In Australia insurers and physicians have joined forces to try to to develop a national program to track hospital and General Practitioner errors and near misses, in the wake of patient safety scandals and a blowout in indemnity costs (Pollard, 2005).

*Table 2.5 Summary of Worrying Healthcare Trends for Governments  
(Johnson, 2003; Messina, 2004; Schou, 2001; Catalano, 2002)*

<b>Medical Errors</b>	<b>Nursing Shortages</b>	<b>Increasing Costs</b>
Incorrect Treatment and Drug Errors Incomplete knowledge of patients' medical histories. Incorrectly prescribed drugs Incorrect administration of prescribed drugs (Johnson, 2003) (Messina, 2004)	United States Figures: On average, nurses work more than eight weeks of overtime per year; (Schou, 2001)	United States Figures U.S. health care expenditures in 2002 increased more than 65% since 1990 and are expected to double by 2007. (Catalano, 2002)

Computer illiterate physicians. Decisions made without access to: Laboratory results Patient histories Allergies Pharmacy information Clinical guidelines	90% of long term care organizations lack sufficient nursing staff to provide even most basic care. This worldwide shortage of nurses forces healthcare organizations to place more and more demands on their already overworked staff	The growing senior population adding to this increase considerably, because as seniors age, they require additional, more expensive treatment. Impact of medical errors, affects length of stay, transfers to intensive care additional tests and treatments
---	--	---

In January 2000, a report issued by the Institute of Medicine (IOM) indicated 98,000 Americans may die each year because of medical errors (Richardson, 2000). These errors are also a major cause of increased hospital stays. The use of computerized records and access to such records via wireless sensor networks and web monitoring should help to alleviate some of the medical errors. The author has designed the MoteCare prototypes keeping in mind that many medical personnel are not computer literate and the system has be easy to use and intuitive for the patient, the physicians and the health care personnel and relatives.

## 2.9 Nursing Shortages

In New South Wales, Australia, a recent report into nursing shortages in NSW hospitals indicated that there will be a national shortage of up to 40 000 nurses by 2010. This is despite the fact that the government of NSW has taken on extra 5 500 nurses in the last four years and resignations have gone down from 16% pa to 14% (Pollard, 2006).

Given the current and projected nursing shortage, health care organizations must find ways to meet demands with fewer and fewer people (Messina, 2004). This is another area where the MoteCare systems should provide assistance via the use of remote monitoring

using Wireless sensor networks and other Information and Communication (ICT) devices in the long term. The ability to integrate sensors for fall detection, video surveillance, sleep disorder monitoring, heart attack identification and problems with obesity, will improve the usefulness of the MoteCare prototype. People will be able to move about in their own home secure in the knowledge that they are being monitored. Just as airplanes are monitored by air traffic controllers, our patients will be monitored remotely by healthcare providers or carers who will have access to the patient's information via a web server and, in the case of an emergency or at a predetermined time, via audio and video link up (Leijdekker et al, 2007). The author intends to integrate IP Webcams in the system to provide this extra security dimension for clients who will feel confident if they know that video surveillance will automatically start in case of an emergency or, if the client requires it, at a specified time.

### 2.10 Increasing Costs

A survey of New England (United States) hospital executives and physicians from 52 (49 community and three teaching) hospitals and healthcare systems across New England, revealed increasing pressure in the relationships between physicians and hospitals as reimbursements fall behind the rising costs of providing care (Market Analysis, 2004).

The healthcare industry has to find more cost efficient methods for servicing the growing number of health care consumers. Economic issues that affect healthcare include:

- rising costs and expanding budget deficits which are difficult to control;
- healthcare is highly regulated;

- ethical and legal issues that can hold up implementations;
- cost of securing medical data;
- cost of developing new drugs and testing them ethically;
- cost of updating computer and communication equipment;
- integration of hospital and healthcare systems;
- management of complex value chains and processes;
- training healthcare personnel and health carers in the use of ICT systems.

The estimated budgets for using mobile or electronic health services in the European Union (specifically for Germany) are illustrated in Figure 2.6.

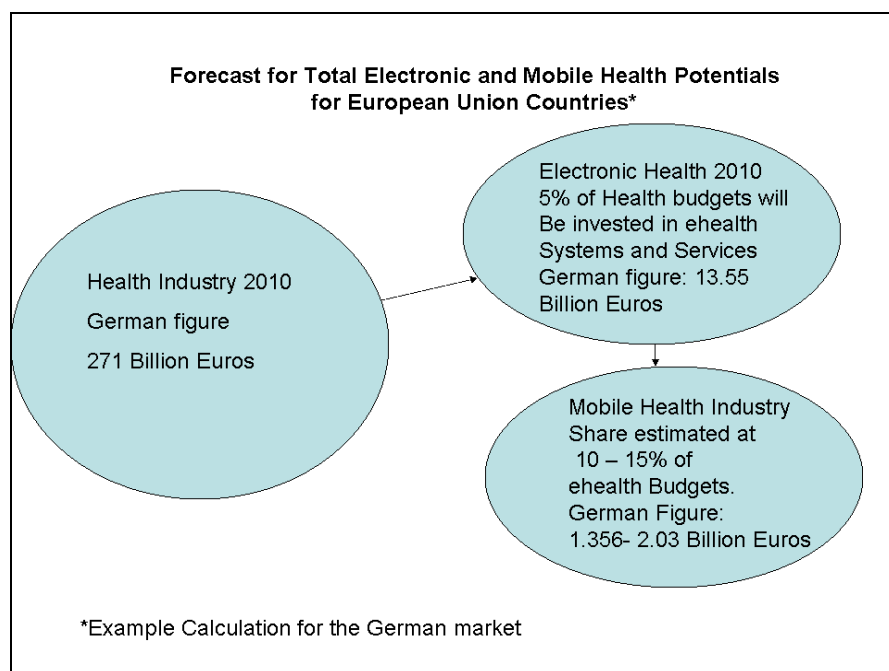

Figure 2.6 Mobile-Health Market Projections (Healthservice24, 2007)

However the following statistics illustrate the potential savings that can be gained by using home monitoring systems that allow patients to

leave hospital early. Healthservice24 provides the following figures from 2004 for the United Kingdom:

Average cost of care per week/per person in a hospital:

GB Pounds 805

Average cost of care per week/per person in a nursing home:

GB Pounds 337

Average cost of care per week/per person in own home:

GB Pounds 120

The following figures from Healthservice24 further illustrate the savings that can be made if mobile health devices are used by early discharged patients in Germany. The figures exclude administrative costs that are also applicable if using a mobile monitoring system.

Early discharged hospital patients using mobile services (20% of total)

3.3 million

Average costs for one hospital day:

150 Euro

Average number of hospital days saved through early discharge:

3 days

Total yearly cost savings through early discharge:

1.5 bn Euro

Thus health economics reveal that potential savings can be made by using mobile and wireless home monitoring devices. Hopefully patients will not be admitted to hospital unnecessarily; they may be discharged earlier; the burden on emergency services could be reduced; medical personnel could remotely assess patients, the patient and relations could reduce their travel times and home visits by experts could be reduced.

Many proprietary companies are now investing heavily in such monitoring and the researcher has seen a gap in the area; namely the use of commodity based wireless monitoring systems that could prove far cheaper than proprietary solutions. The researcher's commodity based prototypes (as explained in Chapters 6, 7, and 8) which make use of open source network management software, further improves the cost effectiveness of the solution provided in this thesis. Furthermore the development of a Heterogeneous Network Management Approach to Wireless Sensor Networks in Personal Healthcare Environments Framework should allow other researchers to follow this innovative method.

## 2.11 Wireless Monitoring Systems

The next section outlines some existing medical monitoring systems which use proprietary devices as opposed to commodity based systems such as the MoteCare system. Telemedicine and wearable computers for health monitoring have been the subject of research for several decades, and in the following section, examples of some promising systems are outlined. It is essential to know the state of the art in health monitoring but it is also necessary to understand that often the elderly, the infirm or the disabled are not computer or mobile literate nor are they able to control some devices because of their disabilities.

### **2.11.1 MobiHealth Body Area Network (BAN)**

In the European MobiHealth Body Area Network (BAN) project (Konstantas, 2004) the researchers developed an architecture based on the General Packet Radio System (GPRS) and the Universal Mobile Telecommunication System (UMTS) technologies for wireless broadband data transfer (Mobihealth, 2003). They are using sensors



and actuators such as the Nonin Finger Clip sensor (Nonin Finger Clip, 2007) to display on a laptop, using a Sensor Viewer window:

- $O_2$  Saturation (Oxyhemoglobin, the oxygen carrying substance found in the blood);
- plethysmogram – a tracing showing variations in size of a finger resulting from changes in the amount of blood flowing through it;
- heart rate in beats per minute.



*Figure 2.7 Nonin 8000KZ Finger Clip (Konstantas, 2004)*

### **2.11.2 Miniature Heartbeat Monitor**

In New Zealand, scientists developed a minute, radio-based device to monitor patients' heartbeats (Collins, 2004). As the world's hospitals spend approximately \$2 billion dollars a year on heart monitoring machines there is potentially a huge market for such devices. This small device is connected to two sensors on the patient's body to record nerve activity. The recorded data is then sent via Bluetooth wireless to transmit the data to a monitoring machine. Patients are therefore able to move around without the need to be wired up to a machine (Collins, 2004). The device could be adapted for use in intensive care units, for monitoring premature babies and for sports medicine as illustrated by the Coach's companion (Coach's Companion, 2003).

### 2.11.3 Digital Plaster

An exciting research development from Toumaz Technology Limited in England is the Digital Plaster Project. This project illustrates how miniaturization in sensing equipment has reached this stage in just three years since the author commenced working on the MoteCare research project.

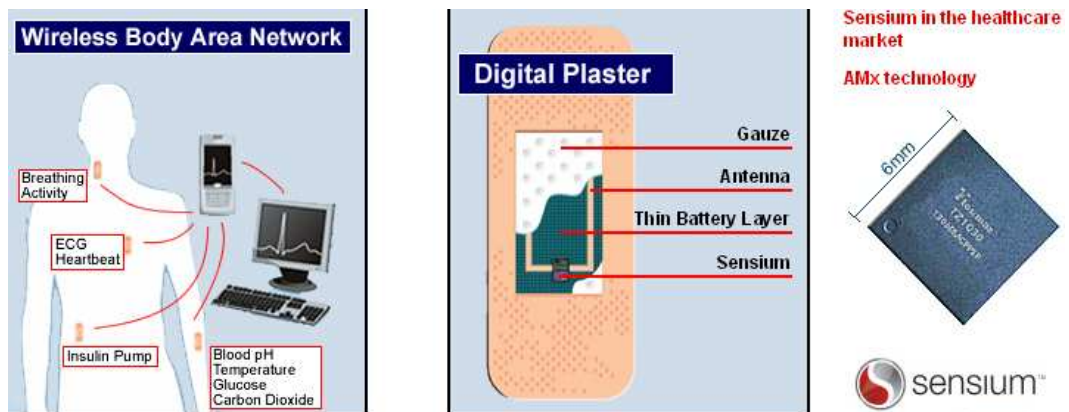

Figure 2.8 The Digital Plaster Project (Digital Plaster Project, 2007)

The advantages of these types of sensors include:

- the small footprint – the antenna and battery layer is paper thin;
- the battery is minute;
- the plaster can be easily discarded;
- the ease of use makes it suitable for elderly and infirm.

The company expects to release the product commercially in early 2007.

## 2.12 Conclusion

This chapter has provided an overview of healthcare issues with particular emphasis on the health problems of the elderly, the infirm and the chronically ill. The fact that people are living longer has exacerbated the problems for governments, communities and healthcare providers and insurance companies. The use of Information and Communication Technologies (ICT) promises to go some way to alleviating these issues. This has spearheaded the development of wireless sensors and handheld devices to facilitate electronic patient record keeping, to allow easy access to patient and other medical information and to reduce the severity of certain of the issues facing the health care industry today. The author has discussed the major problems that beset the healthcare industry such as rising costs, increasing numbers of elderly persons and consequent rise in the number of chronically ill persons. Several examples of wireless monitoring using proprietary devices have been described to illustrate the current state of the art in healthcare monitoring. It is noted that sensors are becoming so minute that they can be placed on plasters. The author reiterates that the first three MoteCare prototypes devised for this research use commodity based hardware and software and are predicated on the use of Network Management tools and system development. In the following chapter three, Wireless Sensor Networks for healthcare monitoring are described and both their benefits and shortcomings are outlined. The author's research indicates that wireless connectivity is essential if these devices are to be a commercial success. In the following chapter the author will discuss Berkeley sensor motes or Motes including their wireless protocols including the Zigbee protocol which is used in the latest Motes which were used in the Medical MoteCare system described in Chapter 8.

# 3. Wireless Sensor Networks for Healthcare Monitoring

*The study of wireless sensor networks is challenging in that it requires an enormous breadth of knowledge from an enormous variety of disciplines (Lewis, 2004).*

## 3.1 Introduction

In chapter two, facts related to the ongoing, global healthcare crisis were highlighted. As well, Information and Communication Technologies (ICT), and more specifically remote healthcare monitoring systems, were suggested as a way to potentially contribute to the improvement of worldwide health systems by providing continuous monitoring of patients or ageing people from their homes or care institutions. Such systems could cut the high costs of providing such care in hospitals or clinics and also offer the advantages of keeping the patients in their own personal environment and with their families and or caregivers.

In this chapter the author describes the main characteristics of wireless sensor networks, the fundamental part of the technology used in the MoteCare health monitoring systems developed for this thesis. The chapter commences with a technology overview of Wireless Sensor

Networks, followed by a discussion of their technical advantages and disadvantages. This chapter closes with an outline of the current status of WSN applications.

## 3.2. Technology Overview of Wireless Sensor Networks

### 3.2.1 History

Although most of the rapid developments in Wireless Sensor networks have taken place since 1999, their history began during the Cold War era (1947 – 1991) with the Sound Surveillance System (SOSUS) designed for military use. The next period of intensive research started in the 1980s at the Defense Advanced Research Projects Agency (DARPA) with its Distributed Sensor Networks Program (DSN) SOSUS (SOSUS, 2006)

Table 3.1 outlines the rapid developments in wireless sensor networks since 1999 and focuses on the work done since the start of what is known as the Smart Dust research at University of California, Berkeley. Professor Pister from Berkeley has been the pioneering force behind the development of these small wireless sensors or Motes. The networks consist of a series of highly miniaturized motes, each of which contains a sensor, often as small as a grain of rice, that detects and records items (such as sound or light); a miniature transmitter/receiver that communicates with other motes; and a small battery that allows operation for longer than a year in a best case scenario. These features allow the network to operate in an autonomous, self-discovering, and self-configuring fashion (Berkeley, 2006). Although there are many other wireless sensor networks under production the research for this PhD has concentrated on Mica2 and MicaZ Motes for research and experiments. The author has worked

with actual motes rather than using simulators throughout the life of this research.

*Table 3.1 Development of Wireless Sensor Networks (ttdp, 2006)*

<b>Device Name</b>	<b>Year</b>	<b>Information</b>
RF Mote	1999	Motes placed on highway to measure the amplitude and frequency of vehicle to infer speed and size of the vehicle
WeC Mote	1999	WeC mote could be reprogrammed over a wireless link, whereas all previous versions had to be programmed through a connector.
Rene	2000	First Mote to be manufactured commercially by Crossbow with TinyOS operating system
Dot Mote	2001	Demonstration at August 2001 Intel Developers Forum (IDF) – 800 of them reprogrammed to demonstrate Network Discovery, Routing, and Aggregation
Mica Mote	2002	By October 2002, following the introduction of the Mica Mote, TinyOS was rewritten in a language developed specifically for TinyOS called NesC
Mica2 Mote	2003	Second generation of the Mica Motes. * The Mica Motes were used by the author of this PHD
Mica2 Dot Mote	2003	Second generation of Mica Dot Mote. The author has used Mica2 motes for the MoteCare System, the Mobile Motecare System and the Stargate Motecare System.
MicZ Mote	2005	Third generation Mica Motes – The MicaZ motes were used by the author for the development of the Medical MoteCare System.

The above mentioned Motes and their specifications are pictured below in Figure 3.1.





Mote Type	WeC	Renee	Mica	Mica2	Mica2Dot
					
<b>Microcontroller</b>					
Type	AT90LS8535	Atmega163	Atmega128	Atmega128	Atmega128
CPU Clock (Mhz)	4	4	4	7.3827	4
Program Memory (KB)	8	16	128	128	128
Ram (KB)	0.5	1	4	4	4
UARTs	1	1	2 (only 1 used)	2	2
SPI	1	1	1	1	1
I2C	Software	Software	Software	Hardware	Hardware
<b>Nonvolatile storage</b>					
Chip	24LC256		AT45DB041B		
Size (KB)	32		512		
<b>Radio Communication</b>					
Radio	RFM TR1000			Chipcon CC1000	
Frequency	916 (single freq)			916/433 (multiple channels)	
Radio speed (kbps)	OOK		ASK	FSK	
Transmit Power Control	Programmable resistor potentiometer			Programmable via CC1000 registers	
Encoding	SecDed (software)			Manchester (hardware)	

Figure 3.1 Summary of Mote Platforms: Developments of Wireless Sensor Networks (ttdp, 2006)

These Motes, like any other new technology, face challenges such as lack of standards, bugs, and especially power limitations. Other known WSNs include the following but these fall outside the scope of this thesis (ttdp, 2006):

- UCLA's iBadge;
- UCLA's Medusa MK-II;
- UCB Piconodes;
- MIT's mAMPS;
- RSC WINS & Hydra;
- Sensoria WINS;
- Ember EmberNet;
- UCB Spec;
- Dust Inc. Dust Mote.

**MicaZ Motes** operate at 2.4 GHz and are IEEE802.15.4/ZigBee compliant. Further details are outlined in the following section.

The next sections define wireless sensor network technologies, describe the technical specifications, and outline the advantages and disadvantages at present.

### 3.2.2 Technical Specifications of the MICA2 and MicaZ Motes

Wireless sensor networks are computerized data networks formed by small wireless nodes which provide physical access to environmental parameters and vital signs. These devices are placed in areas of interest, and collect data primarily about its (their) – to get agreement in number with sentence’s subject immediate surroundings. The sensor technology used for this project comes from the Smart Dust project at UC Berkeley. The hardware developed (named the MICA Mote) is a sensor node that combines the means for sensing environmental parameters, processors, wireless communication capabilities and an autonomous power supply in a single, tiny and low-cost device (Riudavets et al, 2004). The research for the development of the first three MoteCare systems (MoteCare, Mobile Motecare and Stargate MoteCare) has focussed on MICA2 Motes, whose main features are: outlined in Table 3.2 below.

Table 3.2 Mote MICA2 Main Features (Riudavets et al , 2004)

Mote MICA2 Components	Features
MCU (Microcontroller)	<ul style="list-style-type: none"> <li>▪ Atmel ATmega 128L, with 2 serial ports</li> <li>▪ 7.37 MHz, 8 bit processor</li> <li>▪ 128 Kb in Program Memory</li> <li>▪ 4 Kb, SRAM</li> </ul>
Sensor Board Interface	<ul style="list-style-type: none"> <li>▪ 51 pin</li> <li>▪ 7,0 V to 3 V input</li> <li>▪ UART, 2 (Universal Asynchronous Receiver-Transmitter)</li> <li>▪ Other Interfaces: DIO (Digital I/O) with a I2C (Inter-Integrated Circuit) bus.</li> </ul>



RF Transceiver (Radio)	<ul style="list-style-type: none"> <li>▪ CC1000 Chip</li> <li>▪ Radio Frequency of 315/433/915 MHz</li> <li>▪ Max. Data Rate of 38.4 kbps encoded</li> <li>▪ Antenna Connector MMCX</li> </ul>
Flash Data Logger Memory	<ul style="list-style-type: none"> <li>▪ Chip AT45DB014B</li> <li>▪ Connection Type: SPI (Serial Peripheral Interface)</li> <li>▪ Size: 512 KB on-board flash</li> </ul>
Default Power Source	<ul style="list-style-type: none"> <li>▪ Type: 2 Batteries AA (AA,2x)</li> <li>▪ Typical capacity 2000mA-h</li> </ul>

### 3.2.3 MCU (Microcontroller)

A **microcontroller** (or **MCU**) is a computer-on-a-chip used to control electronic devices. It is a type of microprocessor emphasizing self-sufficiency and cost-effectiveness, in contrast to a general-purpose microprocessor such as that used in a Personal Computer. A typical microcontroller contains all the memory and interfaces needed for a simple application, whereas a general purpose microprocessor requires additional chips to provide these functions (Raghunathan, 2006). The computer on a chip is set to revolutionize healthcare monitoring. In late 2004 the United States Food and Drug Administration approved the use of the Verichip for medical purposes. This tiny implantable chip, which can be placed inside a human, stores a code that releases patient-specific information when a scanner passes over it. (Verichip, 2006)

The microcontroller or MCU model built-in the MICA2 mote is the ATmega 128L from Atmel, which is a low-power, complementary metal-oxide-semiconductor (CMOS, 2006). The two main characteristics of CMOS devices are their high noise immunity and low static power supply drain (CMOS, 2006). The latter is extremely important for these miniaturized sensors as it helps to extend the

limited source of power which, for the MICA 2 motes used in this research, is two AA batteries. More information about the power source of these devices will be explained in section on batteries in this section.

#### **3.2.4 The Sensor Board Interface**

The Sensor Board Interface (MIB) in the MICA2 Mote is a detachable data acquisition component that contains the sensor or group of sensors which measure some of the various physiological or environmental parameters required for the application. The MIB has a 51-pin female expansion connector from Hirose manufacturer, as well as analog and digital I/O interfaces. The Universal Asynchronous Receiver-Transmitter (UART) translates between parallel bits of data and serial bits. This integrated circuit is used for serial communications from the MIB to the MCU (UART, 2006). The digital I/O interface (DIO) comes with a I2C (Inter-Integrated Circuit) bus, a simple bi-directional 2-wire bus for efficient inter-IC control. The sensor board of a MICA2 mote can be modified to add other sensors, such as an oximeter sensor implemented to measure levels of oxygen in the blood used on the CodeBlue project for emergency medical care (Malan David, 2004) at Harvard University as shown in Figure 3.2 below. CodeBlue is further described in Section 3.3. The Medical Motecare system developed for this thesis is described in detail in Chapter 8.

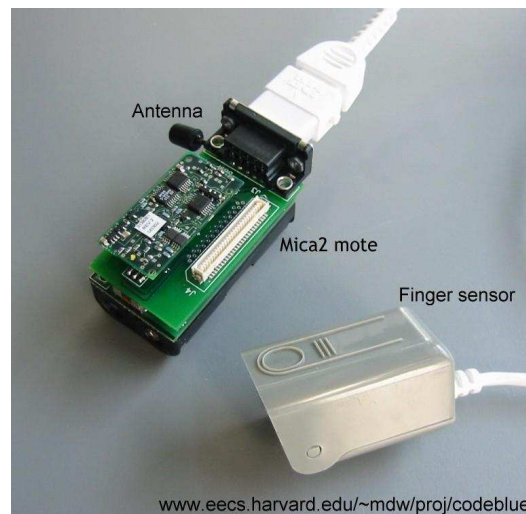

Figure 3.2 Oximeter Attached to MICA2 Mote (VitalDust, 2006)

### 3.2.5 RF Transceiver (Radio)

The motes utilize an RF transceiver chip capable of multi channel operation, within the intended band of operation with radio frequencies of 315, 433 or 915 MHz. Features include:

- max. Data Rate of 38.4 kbps encoded;
- antenna Connector MMCX.

The MPR420/MPR520 can span up to 4 channels of operation in the 315 MHz band (Japan only), the MPR410/MPR510 can span up to 4 channels of operation in the 433 MHz band (433.05–434.79 MHz). The MPR400/MPR500 can operate in two frequency regions: 868–870 MHz (up to 4 channels) and 902–928 MHz (up to 54 channels). The actual number of possible channels is higher for all the MICA2/MICA2DOT motes. However, it is recommended that the adjacent channel spacing should be at least 500 kHz to avoid adjacent channel interference thereby reducing the number of available channels.

Several factors affect the power consumption of the radio including (Raghunathan, 2006):

- modulation schema;
- data rate;
- transmit power;
- operational duty cycle.

The radios can operate in the following modes, namely Transmit, Receive, Idle and Sleep. Raghunathan et al (2006) point out the leaving the radio is idle mode results in power consumption that is almost at the level of power consumed in the Receive mode. Other radio issues that must be borne in mind, especially if the devices are to be used in medical situations, include the following:

- a) the radio should be shut down completely when not in use. Idle mode should be avoided;
- b) when the radio's operating mode changes, be aware that there is a lot of power dissipation (Raghunathan, 2006).

As reported by Tanenbaum et al (2006) much research on sensors has been done in laboratory simulations but 'has not addressed the system challenges associated with deployment in real world conditions'. Their research has shown, for example, that the radio range in an open field is about 7 metres whereas if the mote is raised to about 1 metre in height the range increases to 35 metres. This type of variation would need to be taken into account when deploying health monitoring systems for elderly or ill persons (Tanenbaum, 2006).

### 3.2.6 Flash Data Logger Memory

The flash data logger memory allows for up to 4-Mbit of storage with the serial flash hardware component from Atmel AT45DB041 included in all motes. This data logger allows the storing of data originated from sensor measurements and other user defined information. The flash data logger memory connects to one of the UART on the MCU ATmega128L (Fig 3.2). The serial flash device supports over 100 000 measurement readings, and it is also used for the over-the-air reprogramming services available in TinyOS (Crossbow, 2006).

The importance of this component on mote-based personal healthcare monitoring applications is that in the case of transmission problems such as network congestion or significant drops in bandwidth, the flash data logger could temporarily store the data from the monitored patient, or user, to then retransmit it once the network allows for it. The disadvantage is its limited capacity to store data (4-Mbit) which can easily become insufficient when monitoring constantly, as would be the case in health monitoring. However, as the technology improves, extra storage capacity will be added to the devices. Part of the reason for the researcher using a server (MRTG) in the MoteCare prototype is to cope with the handling of large streams of data. This aspect will be explored further in Chapters 6, 7 and 8 on building the MoteCare systems. Another important factor, which has to be taken into account when developing applications, is the amount of power that this component consumes when writing data (about 15 mA).

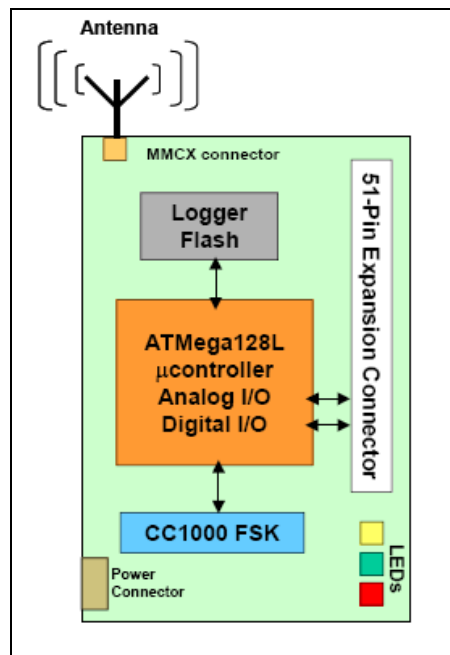

Figure 3.3 Block Diagram of the MICA2 (Xbow, 2006)

### 3.2.7 Default Power Source

The default power source for the MICA2 motes is two AA batteries whose typical capacity is approximately 2000mA-hr, allowing these devices to last from weeks to even years depending on the characteristics and frequency of the task(s) they were programmed to perform. Such tasks can consume energy at various different levels depending on a number of variables such as the frequency that the mote gets into an active state for processing, sensing, writing, and the range and incidence of the data transmission among others.

One of the most significant features of the motes is that they are designed to work at the microvolt level and their standard behaviour is to go to sleeping mode between operational task intervals. Such a characteristic becomes extremely important when monitoring subjects at their own homes, as it is important to allow for continuous

monitoring periods as long as possible without the need for changing the batteries constantly. On the other hand in personal healthcare monitoring, it is essential that the monitoring device does not go to sleep at a critical time – for example, when the monitored person has a heart attack.

As mentioned earlier, if the motes are not directly connected through an external power source they are connected to batteries. In the case of the MICA2 platform the power requirements in various operations are shown in Table 3.3 below.

*Table 3.3 Mote MICA2 System Power Consumption Requirements  
(www.xbow.com)*

<b>Operating Current (mA)</b>	<b>MICA2</b>
ATMega 128L, full operation	12(7.37 Mhz)
ATMega 128L, sleep	0.010
Radio, receive	7
Radio, transmit (1mW power)	10
Radio, sleep	0.001
Serial flash memory, write	15
Serial flash memory, read	4
Serial flash memory, sleep	0.002

Raghunathan et al (2006) list the following battery operation issues that impact on wireless sensor networks:

- dimensions of the battery;
- type of electrode material;
- diffusion rate of the active materials in the electrolyte.

As well, Raghunathan et al (2006) note that with some battery types the 'minimum required current consumption often exceeds the rated current capacity, leading to sub-optimal battery time' (Raghunathan et al, 2006). The source of power the motes is one of the main challenges when constantly monitoring a patient as the motes are designed to be "awake" for small periods of time and go back to "sleep" when not being utilized to save power. This sleeping state becomes a disadvantage when a variable must be constantly monitored as, in this scenario, the mote would need to be "awake" for most of the monitoring time, thereby shortening severely the mote's overall battery life time. Intense research is currently being done for alternative energy to power up miniaturized networked sensors. These sources can range from scavenged ambient power such as the Low-level vibrations occurring in common household and office environments (Roundy Shad, 2003) to sensors that can be powered up from our own bodies (Rhodes, 1996). Some other power sources utilize light, temperature, vibration, kinetics and magnetic fields. However the main power challenges have remained the same for a few years, namely not only to provide an long term battery life time for the various applications, but also to keep it to an appropriate size and affordable cost for its purposes.

### **3.2.8 Over- the-air Programmable and Unique ID Identifier**

Figure 3.4 shows a Mica2 Mote without its antenna as well as the plan view. It is noteworthy that the size of the battery is much larger than the actual Mica2 mote. If the antenna is added the physical footprint of the mote increases. Figure 3.9 also shows a Block Diagram and Schematics of the MICA2 Mote (MPR400/410/420).



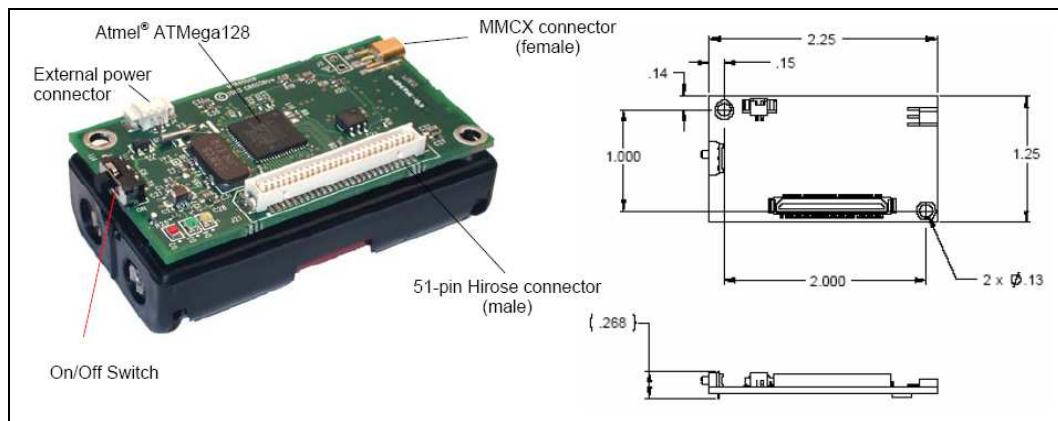

*Figure 3.4 Photo of a MICA2 (MPR4x0) Without an Antenna (left) and Top and Plan Views Showing the Dimensions and Hole Locations of the MICA2 PCB Without the Battery Pack (right) (MPR400/410/420)*

It is important to take into account the ergonomics of the motes as users would be carrying or wearing one or more of these devices. Figure 3.4 shows the top and plan views of a MICA2 with its photo and dimensions detailed. Notice that the mote's portability, wireless transmission and size (even with the two AA batteries power source and antenna) can facilitate its use, increase mobility and be carried by many users in contrast to a more traditional health monitoring methods. Further discussion of practical issues of wearing these motes will be undertaken in Chapters 7, and 8 covering the building and testing of the MoteCare systems. Older monitoring methods, in many cases, result in a dense wired environment of electrodes where the patient is directly attached to a bed-sized fixed health monitoring unit, as in older heart monitoring or pregnancy monitoring devices. In situations such as in daily health-activity performance monitoring, or when working with continuous moving subjects (as could be the case of children), it becomes extremely difficult and sometimes even impossible to perform such monitoring effectively.

### 3.2.9 Radio Spectrum

The radio spectrum, data rates and data ranges of the motes (depicted in the oval titled TinyOS) wireless technologies are shown below in Figure 3.5.

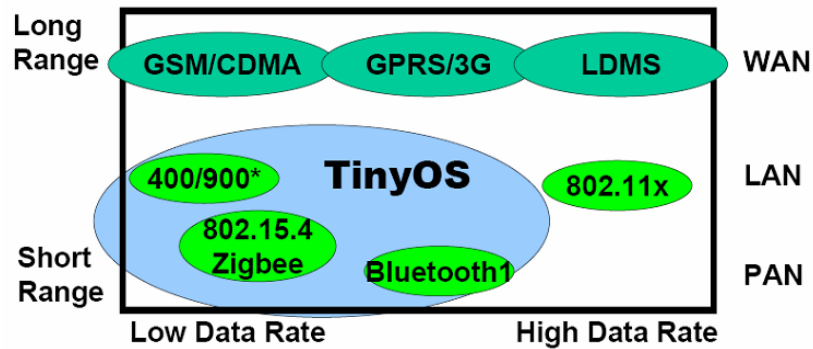

Figure 3.5 Motes Radio Spectrum (Koubaa, 2005)

The radio spectrum that the motes utilize is in the ultra high frequency (UHF) band with a wavelength spectrum of 400/900 MHz, or on the 802.15.14 standard and Zigbee technology [Fig 3.5]. Other known UHF short range band equipped devices are wireless home phones, mobile phones, wireless LANS and Bluetooth powered devices. Although the IEEE 802.15.1 Wireless Personal Area Networks (WPAN) standard and IEEE 802.15.2 (coexistence of WPAN including Bluetooth, and WLAN devices) have been considered as potential solutions for some WSN applications, these protocols have some important limitations in this context. These IEEE 802.15.1 and IEEE 802.15.2 protocols have not been designed to fit the inherent requirements of WSNs in terms of power consumption, data rate, timing constraints and cost (Koubaa, 2005).

The new generation of motes is now using ZigBee transmission protocol built on the IEEE 802.15.14 standard. This low rate, wireless, personal-area-network standard was ratified for the first time in December 2004. ZigBee technology uses the unlicensed 2.4GHz

worldwide, 868MHz in Europe, and 915 MHz in the Americas. Even though ZigBee uses the same frequency bands as IEEE 802.15.1 and IEEE 802.15.2 this technology implements different modulation schemes, in order to enhance power management (Koubaa, 2005). ZigBee has quite a few other advantages such as the capability of define a mesh network topology with interoperable application profiles and security features using 128 bit Advanced Encryption Standard cryptography and trust-centre-based authentication (Geer, 2005), (refer to Fig 3.6). ZigBee is built on the robust physical and media access control layers defined by the IEEE 802.15.4 standard. Above these layers, ZigBee defines a mesh network topology with security features and Interoperable application profiles (Geer, 2005). Once the ZigBee technology was inbuilt in the motes and commercially available, the researcher obtained a set of MicaZ motes and utilized them in the building of the Medical MoteCare system presented in detail in chapter 8 of this document.

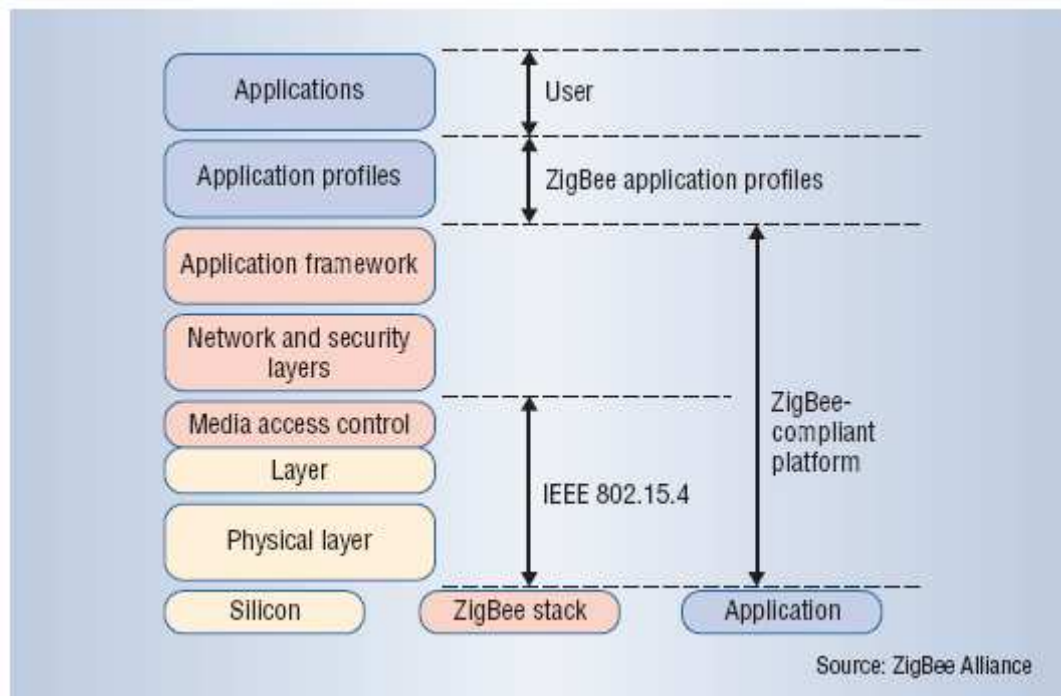

Figure 3.6 ZigBee Stack (ZigBee Alliance, 2006)

### 3.2.10 Operating System

These devices run a specialized operating system called TinyOS developed by the Berkeley researchers. This tool has been specifically developed to manage all the operations related to the motes. The TinyOS system, libraries, and applications are written in nesC (*reference*), a new language for programming structured component-based applications. The nesC language is primarily intended for embedded systems such as sensor networks. nesC has a C-like syntax, but supports the TinyOS concurrency model, as well as mechanisms for structuring, naming, and linking together software components into robust network embedded systems (Riudavets et al, 2004).

### 3.2.11 Next Generation

In the future the third generation mote, namely MICA2DOT from Crossbow, is expected to be implemented in this work. The MICA2DOT platform is very similar to the MICA2, except for its quarter-sized form factor and reduced input/output channels, features that make the MICA2DOT better suited for commercial deployment. The MicaDot motes (see Figure 3.7) have been considered for future deployment in this project as, because of their size, they are easier to adapt to wearable devices, such as those to be used in a Body Area Network. It is also important to note that miniaturization of sensors is occurring very rapidly as seen by the development of Digital Plaster, discussed in Chapter 2.

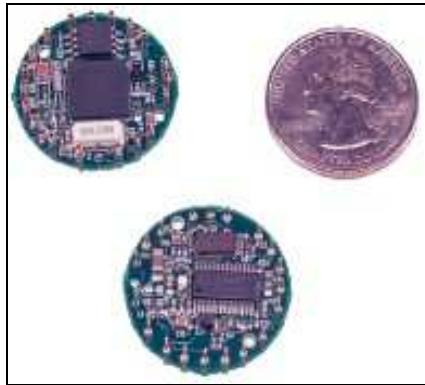

Figure 3.7 MicaDot Motes (Crossbow, 2006)

### 3.3 Technical Advantages and Disadvantages of Wireless Sensor Networks

Compared with traditional data logging systems, networked sensors offer two major advantages: they can be re-programmed “in-situ”, and they can easily communicate with the rest of the system. “In-situ” re-tasking allows scientists to refocus their observations based on the analysis of the initial results. For example, if some heart-rate trouble is detected in a certain patient, doctors would be able to change the sensing rate, increasing it. The other great advantage is that sensors typically form a multihop network by forwarding each other’s messages, which vastly extends connectivity options. This is very useful when some motes are not in the coverage area of the base station, and communicate with neighbour motes to reach the base station (hierarchical structure). In the author’s application, all the motes are in the coverage area, so the multi-hop network feature will not be deployed. However this would be part of the next iteration of the research (Lubrin et al, 2005).

When discussing the advantages and disadvantages of wireless sensor network platforms such as motes, it is important to mention how the

design factors of the data link can play a most important role in terms of real-time guarantees, energy efficiency, scalability, throughput, latency and reliability. Such varied design implications have dramatically increased the complexity of finding the ideal balanced and cost-effective solution across the wide range of diverse WSN applications. For instance a MAC protocol design that perfectly mitigates power consumption in a sensor node might be inadequate if it does not take into account the timing constraints of certain applications. In other words some WSN applications can be more sensitive to real-time guarantees such as healthcare monitoring, emergency control, fire alarm and motion monitoring applications while others may be more demanding in terms of network lifetime and thus energy consumption such environmental monitoring and home automation (Koubaa, 2005).

In personal health environment monitoring, applications can employ duty-cycling management to achieve good lifetime limitations with reasonable communication and computation rates, as the motes consume roughly 20mA when active resulting in a battery lifetime of 5-6 days if continuously running, but can also drop to a very low power sleep state of 10 $\mu$ A, increasing life time to over a couple of years. At the application level, such duty-cycling management can become crucial to be able to maintain an effective and responsive health monitoring system and, in many cases, this will depend on the parameters being sensed. For instance in applications where the monitored parameters do not experience sudden changes, one reading every 5 minute interval could be enough, as might be the case of body temperature, or sugar levels in the blood stream. However, in the cases where the monitored parameters may alter in a short period of time, the readings have to be done in a more frequent manner, as it could be a matter of just a few seconds in the intervals being the

difference between life and death of the person being monitored in an emergency situation.

Given such heterogeneous requirement frames, there is still no predominant standard solution for WSNs, but rather a large set of MAC protocol designs that could each independently, or in conjunction, be more suitable for specific application demands. The MAC protocol solution designs can be classified into the following groups depending of the main intended problems to be addressed:

- scheduling-based protocols where the sub channels do not interfere with each other;
- collision-free protocols;
- contention-based protocols (Koubaa, 2005).

Ye and Heidemann (2004) contend that the characteristics of WSNs, namely:

- their battery power source;
- their ad hoc deployment;
- difference in node density;
- bursty traffic;

mean that traditional MAC protocols are not suitable for WSNs without some modifications. Their specific WSN protocol S-Mac is outside the scope of this thesis (Ye and Heidemann, 2004).

### **3.3.1 Disadvantages: Motes and Security**

Security is another major issue that is challenging researchers and the following table illustrates some of the current thinking on how to secure wireless sensor networks. The issue is especially relevant in the

case of healthcare data. Experts from Berkeley believe that security for motes must be integrated into every component as components designed without security are the vulnerable points where attacks start (Culler, 2004).

*Table 3.4 Security and Motes Source (Culler, 2004)*

<b>Method</b>	<b>Comment</b>
Key establishment	Traditional methods will not be able to scale up adequately with hundreds of nodes.
Trust setup	Necessary to establish a secure and efficient key distribution for large scale sensor networks.
Secrecy & Authentication	Research has indicated that software only cryptography is practical with motes

Another issue that needs to be addressed is to ensure that the sizable data stream of information regarding the patients does not overwhelm the medical personnel and does not clutter the information system with unnecessary detail. Sensors are capable of sending vast streams of personal, private, medical information wirelessly where it could be intercepted by unauthorized people or perhaps mishandled by medical/office personnel who could be unused to handling such large streams of information and who may be unable to work out which data should be kept and which discarded in a safe fashion. The huge data stream of information regarding the patients must not overwhelm the medical personnel and clutter the information system with unnecessary detail. Healthcare providers or others who have access to health information and do not act on it may incur substantial liability (Riecki, 2000). The accuracy and security of vital medical information received from motes must be maintained and is an area for further exploration.



If motes move into critical healthcare applications they may be subject to regulation as medical devices (Riekkki, 2000).

### 3.4. WSN Applications

The following section provides an overview of the current state of the art with Wireless Sensor Network applications.

#### 3.4.1 Current State of Technology

Wireless Sensor Network applications have expanded across a wide range of different areas such as military, environmental, smart environments, robotics, health and some other commercial applications (Arampatzis, 2005). The multifaceted aspect of WSN can potentially get as far as, but are not limited to, any area where the correlation of an event and the monitoring of one or more "sensed/measurable" variables in time can be relevant to human kind. One of the reasons behind this logic lies on the principle that sensor networks can integrate many different types of sensors. These include seismic, low sampling rate magnetic, thermal, visual, infrared, acoustic and radar sensors, which are able to monitor a wide variety of ambient conditions that include temperature, humidity, vehicular movement, lightning condition, pressure, soil makeup, noise levels, the presence or absence of certain kinds of objects, mechanical stress levels on attached objects, and the current characteristics such as speed, direction, and size of an object among others (Akyildiz, 2002).

Although a wide range of applications was discovered in the literature review for this project, the number of publications detailing WSN applications is still a small percentage when compared to the number of publications on WSN problems. The bulk of the existing research is concentrated on hardware problem solving, the development of

wireless protocols for these devices; wireless communication, MAC layer, routing and security issues. Furthermore some of the existing applications have not reached the experimental phase, as many of these projects have used software simulations and modelling for testing purposes. Even fewer have crystallized to the commercialization of a service or a product for the final user. Such findings reinforce the fact that WSNs are still considered to be in the early stages of development and adoption of the technology. The many and varied areas of existing and proposed applications, which demand uneven sets of requirements in hardware and software for implementation, along with the lack of standards, fault tolerance and error rates, have hindered the incursion of WSN technologies in our daily life activities.

### 3.4.2 Categorization of WSN Applications

In the following subsections the researcher sets out some of the developed applications categorized according to surveys from Akyildiz et al, 2002 (Akyildiz, 2002) and Arampatzis et al, 2005 (Arampatzis, 2005). This section concludes with coverage of some proposed WSN Health applications. The literature review has not shown a commercial implementation of any of the healthcare WSN at this stage of writing the thesis.

*Table 3.5 Military WSN Applications*

Examples	Researchers
<ul style="list-style-type: none"> <li>▪ Monitoring friendly forces, equipment and ammunition</li> <li>▪ Detection classification, and tracking of targets</li> <li>▪ Battlefield surveillance</li> <li>▪ Detection of hostile units</li> <li>▪ Reconnaissance of opposing forces and terrain targeting</li> <li>▪ Tracking and classification of vehicles and armed soldiers</li> </ul>	Arampatzis, 2005 Li, 2002 He T., 2004 Chu M., 2004 Meesookho C., 2002 NEST team, The Ohio Sate University, 2003

Table 3.6 Environmental Monitoring Applications

Examples	Researchers
<ul style="list-style-type: none"> <li>▪ Indoor environmental monitoring and emergency services</li> <li>▪ Forest fire detection</li> <li>▪ Biocomplexity - mapping of the environment</li> <li>▪ Flood detection</li> </ul>	Kintner-Meyer and Brambley, 2002 Chandrakasan, 1999 Cerpa, 2001 Bonnet, 2000

Table 3.7 WSN Applications in Home Automation and Smart Environments

Examples	Researchers
<ul style="list-style-type: none"> <li>▪ Home Automation</li> <li>▪ Smart Environments</li> </ul>	Petriu, 2000 Abowd, 2000 Essa, 2000 Herring, 2000

For many years researchers have been trying to develop commercially viable applications for sensing networks. However, as mentioned earlier in History Section, Wireless Sensor Networks really started to come to the intense interest of the research community in the early 2000s and as yet have not been adopted in large scale commercial environments. Other types of proprietary medical sensors have been deployed and examples of such are found in Table 3.8.

Table 3.8 Research on Health Monitoring Applications Other than WSNs

Examples	Researchers
Health monitoring	Bulusu, 2001 Kahn, 1999
Telemonitoring of human physiological data	Noury, 2000 Osler, 2002
Tracking and monitoring doctors and patients inside a hospital	Rabaey, 2002 Warneke, 2001 Johnson, 1996
Drug administration in hospitals	Celler, 1994 Coyle, 1995
Heart Rate and Blood Saturation monitoring Personal Heart Monitor	Sibbald, 2001 Leijdekkers et al, 2007

In each of the above cases, the systems have been proprietary and therefore expensive and tied to a particular manufacturer. In this thesis the aim is to see whether open source hardware and software could be used in place of proprietary systems. This would have advantages such as lowering the cost, ensuring a continuing cycle of improvement via the open source community and reliability. In Chapter 8, the author will show that proprietary software was required to provide the necessary level of sophistication for the Medical MoteCare system.

### 3.4.3 Measurements and Sensors

Widya et al (2003) state that it is 'well known that appropriate medical intervention during the 'golden window' immediately following an accident significantly improves the chance of recovery for a patient (Widya et al, 2003). In July 2004, the author visited researchers at Harvard University who are working on a research project named Vital Dust (Johnson and Johnson, 2003). The Harvard team was working with a device to collect pulse oximeter information (heart rate and

blood oxygen saturation) with a sensor that clips onto a patient's finger. This sensor is attached to a mote which transmits data to a PDA or a laptop. The Harvard researchers believe that their work could lead to a more rapid triaging system since the emergency personnel at a major casualty event will be able to triage on site as soon as the information is relayed via motes to their receiving devices. The workers will also be able to identify the patients most in need of care immediately and improve the chances for a rapid response. Figure 3.8 shows how such a system could work.



Figure 3.8 Motes and Medical Monitoring (VitalDust, 2006)

A close collaboration research with Professor Matt Welsh from Harvard University since 2004 has facilitated for this project the use of assistive software and hardware specifications for the development of MoteCare. The Vital Dust Project has been renamed CodeBlue (Malan, 2004). CodeBlue has an impressive range of monitoring techniques thanks to a large team of funded researchers but Professor Welsh moved on to sensing of Volcanoes and made the CodeBlue software available to the Open Source community to further develop and enhance. However, the MoteCare system developed for this thesis is unique in that it has utilized Network Management techniques and tools for its architectural specification as well as the use of external open source databases. No simulations were used in the author's MoteCare system. In the final

prototype the researcher integrated a component of the CodeBlue Software to facilitate the incorporation of a specific medical sensor, namely a pulse oximeter, into the Medical MoteCare system to further demonstrate the feasibility of the handling of actual medical data with Network Management tools.

### 3.5 Conclusion

In this chapter a description of wireless sensor network technologies has been provided, with particular focus on the MICA2 and MicaZ Motes which are utilized in this research thesis. The main design characteristics of these devices along with the advantages, disadvantages and applications of the technology were presented. At the end of each section, a grounding of the technology was placed in the context of personal health monitoring applications, and, in some cases, in the MoteCare research projects.

The technical characteristics of the motes, such as their flexibility, fault tolerance, high sensing fidelity, low-cost and rapid deployment allow for many opportunities to explore wireless sensor network applications. These can offer an extra layer of information about the environment and our human body. The varied applications of this technology go from military uses to aerospace or electro domestic appliances for smart homes. In the area of Personal Health monitoring these sensors allow for more mobility for the person being monitored as opposed to the use of traditional wired sensors, and could even, in some cases, enhance the quality of living for people with chronic diseases – as they can be constantly monitored for potentially hazardous thresholds in their condition. For instance, specific sensors could issue a set of alerts before a diabetes patient reached high sugar levels. However it must be noted that there are many problems that must be solved before this technology can be placed in a real time, commercial or healthcare

environment. In the following chapter the author will provide an overview of how Network Management tools were used to provide a framework for the development of the MoteCare systems.

## 4. A Network Management Approach to WSN Applications in Personal Healthcare Monitoring

*Information Technology is used to document diagnoses and treatments and little else. However, Information Technology can do much more if used effectively. Data gathered from various sources can provide information to consumers and providers alike to not only prevent disease but also develop wellness. This is particularly true in the ageing population whose care can be facilitated by the effective use of Information Technology (Georgeff, 2007).*

### 4.1 Introduction

This chapter provides an overview of how Network Management tools helped to provide a framework for the development of the MoteCare prototypes. It illustrates the common features that are useful for health monitoring and introduces the use of the systems that have been built to demonstrate the adaptability of these Network Management tools to healthcare and environmental monitoring for the elderly, the ill and the infirm. The documented healthcare issues in Chapter 2 illustrated the need for the use of Communication and Information Technology to help alleviate some of the issues raised in



that chapter. These issues included economic ones such as the increase in the percentage of Gross Domestic Product (GDP) consumed by health and aged care. Social issues included an increase in the percentage of older people in the population and rises in the incidence of chronic disease. Advances in medical technology and pharmaceuticals have led to increases in longevity. As well there is a trend for more independence for older people and both the aged people themselves and many governments are now encouraging care services to be delivered in the home and community. Other canvassed items included the loss of appropriately skilled and trained medical staff.

Chapter 3 indicated the potential advantages of using Wireless Sensor Networks in Healthcare Monitoring and also pointed out some of the shortcomings of this relatively new wireless technology. It also noted that much work on Wireless Sensor networks to date have used simulation software whereas the author of this thesis has concentrated on using actual wireless sensor networks for the development of the four MoteCare systems. This was done as part of the effort to show that commodity based hardware and open source software could potentially save money in the healthcare monitoring situation. In this chapter, the researcher explains how the adaptation and implementation of network management methods and techniques could act as a catalyst in the development of robust wireless sensor network (motes) applications for health monitoring purposes. Therefore, this chapter underpins the development of a generic, heterogeneous network management framework suitable for healthcare applications (see Chapter 9 for a detailed description of the framework). Network Management terms were introduced in Chapter 1, Table 1.2.

## 4.2 Why Network Management?

For more than two decades research in the area of Network Management has been focused on solving similar problems to the ones that WSNs are facing in the development and deployment of the majority of applications such as those set out in Chapter 3. In order to understand how these different models and techniques can assist in this endeavour, it is important to comprehend the principal issues that these network management tools are trying to solve or address.

The effective polling, monitoring, storing and fusing of vast amounts of data coming from hundreds and sometimes thousands of network devices have been challenges that needed to be urgently addressed by the researchers in the area of Network Management in the early 80s. Organizations started to rely heavily on computer communications to perform their daily business processes and with this, the heterogeneity and complexity of the networks dramatically increased, as did the level of difficulty and costs to manage them (Cisco, 2006).

This situation was not only damaging the revenues of private enterprise, but also started affecting all other types of organizations, both profitable and non-profitable, which could not afford an effective management level. In some cases, the network downtimes over exceed the entropy threshold levels supported by their own information systems (Cisco, 2006).

As a result of this scenario, various models and techniques have been developed in order to automate and assist in the solving of these difficulties. Originally, most Network Management strategies were designed for the 'wired world' (Castaneda, 2006). Additional challenges adapting such 'wired' Network Management strategies to the wireless world were also faced in the development phases of this thesis. In this

chapter, Network Management techniques and models are explained and an analysis and discussion about those characteristics that potentially could benefit the field of wireless sensor network healthcare application development are presented.

### 4. 3 Network Management Concepts and Techniques

In general, Network Management is a service that employs a variety of tools, applications, and devices to assist human network managers in monitoring and maintaining networks (Cisco, 2006). A Network Management System (NMS) can be either a centralized or distributed system which aims to manage the various components of a network by collecting information from sometimes hundreds of different devices to monitor their status and react to, or even anticipate, undesirable behaviours in the network as a whole. Summarizing, an NM system is an Information System applied to the management and monitoring of vast numbers of heterogeneous communicated network devices which are handling and dealing with vast amounts of data/information. In the literature, Network Management definitions vary. In some cases it involves a solitary network consultant monitoring network activity with an outdated protocol analyzer. In other cases, Network Management involves a distributed database, auto polling of network devices, event-driven alarm systems and high-end workstations generating real-time graphical views of network topology changes and traffic. With this description it is easy to see the similarities between a NMS and a WSN Application for Personal Health Care purposes: the system monitors the various sensors on or in the body or the nodes in a network. The researcher will demonstrate the use of the above four items, namely a distributed database, auto polling, an event-driven alarm system and graphical views in the built MoteCare systems, namely MoteCare, Mobile MoteCare, Stargate MoteCare and Medical MoteCare (see Chapters 7 and 8).

The next section describes functions common to most Network Management architectures and protocols, as well as the five conceptual areas of management defined by the International Organization for Standardization (ISO).

## 4.4 Network Management Architectures

The majority of the established Network Management Architectures conform around a basic structure and set of relationships. The managed devices, namely network devices or nodes or other computer systems are continuously polled for information relating to their functional status (e.g. whether they are connected or not) or to acquire other node's data (e.g. node id for identification purposes) (Lewis, 2005). The polling devices or the management entities can be centralized or distributed; these entities collect and filter the information obtained from the managed devices. These management entities can take decisions with different levels of intelligence by discriminating the collected data and determining the existence (or not) of anomalous behaviour in any of the individual managed devices. More sophisticated NM systems would diagnose the functioning or performance of the network as a whole. As an example, a critically high temperature in one router processor might threaten the stability of the network at a lower risk level than if there were numerous router processors with the same high temperature conditions. These more sophisticated NM systems may establish the anomaly's level of severity by evaluating its impact or disruption level on the network (Lewis, 2005). These NN systems utilize for this purpose algorithms of varied complexity which would normally dictate the level of intelligence of the NM system.

At the same time, managing patients in a medical context has also much in common with classic network management. It is all about

collecting data samples (like link usage or heart rate) from a large number of entities (like switches or patients), interpreting this data, triggering alarms or predicting trends (Fischer, 2008).

Continuous polling of vast numbers of network devices in quite short intervals can sometimes be overwhelming for the network management system. This polling implies additional traffic in the network and results in tremendous amounts of data being collected, filtered, stored and processed by the management devices. In order to avoid unnecessary burdens for the network management system, the frequency of the polling of the different network devices can also vary or could be set according to that previously explained level of significance (or disruption implications in case of failure) for the network. For example, a storage or mail server that is continuously accessed by most of the other devices in the network would be considered of a much higher significance (or even classified as critical in some cases) and therefore set a more frequent polling criteria, than an end user workstation that is rarely accessed by any other entity in the network. Similarly in the scenario of having a WSN based health monitoring application, a particular node monitoring critical data such as blood pressure or sugar level would be, for instance, polled more frequently than a sensor monitoring skin temperature which may be considered as relatively of less importance in the detection of a critical health event.

To further illustrate this in the network arena, another example could be the further discrimination of the nodes that also act as traffic forwarders (routers) that ensure a connected network, over the ones that only sense data to meet application requirements (Perillo, 2006). Previously illustrated NM discriminating techniques, such as the frequency of a device being accessed by other entities, the number and importance of services offered, or the measurement of

connectivity disruption on the network per node, among others, are also examples of the type of variables that can be utilized by a NM system algorithm to *weigh* and determine the criticality of a given event, or a series of events in the network, and hence be able to *diagnose* the health status of the network as a whole. In a similar manner these algorithms can be adapted to incorporate sensor nodes variables of specific scenarios for a WSN healthcare monitoring application to allow for the prioritizing and fusion of a mix of events and evaluate the criticality of the patient being monitored at any given situation. This aspect will be demonstrated in Chapter 8.

Another NM technique that aids reduction of the amounts of traffic caused by intense periodical polling intervals, and adds accuracy to the timing when discovering and reacting to network faults is the triggering of so called 'traps'. Traps are messages or alarms sent by the managed devices, or end nodes, notifying the management entity of the presence of an undesirable event. This process is normally achieved by embedding software modules (agents) into the managed devices which can detect the reaching of previously configured sets of thresholds, and react to them by notifying the nearest management or monitoring device (Lewis, 2005). Thus, it can be seen that such software agents in a wireless sensor health monitoring system potentially could react to adverse health sensor data to alert health carers to a looming problem. For example, a rise in temperature of a monitored person could indicate the onset of a fever, or a rise in blood pressure could alert medical officials to the possibility of a stroke. Thus it can be that medical monitoring has a lot of overlapping concerns with network management (Fischer, 2008).

## 4.5 The OSI/ISO Network Management Model

The International Organization for Standardization (ISO) (in French; L'Organisation internationale de normalisation) is the world's largest developer and publisher of International Standards. It is composed of representatives from various national standards bodies from 157 countries. The organization produces world-wide industrial and commercial standards. ISO has more than 16 500 International Standards and other types of normative documents in its current portfolio. ISO's work ranges from a wide range of standards from traditional activities, such as agriculture and construction, to transport, medical devices, information and communication technologies among others (ISO 2007). In the area of information and communication technologies ISO has closely contributed to the standardization of Networking, forming in 1982 the Open Systems Interconnection (OSI) group along with the International Telecommunication Union Telecommunication Standardization Sector (ITU-T). ISO under the direction of the OSI group, created the OSI/ISO network management model (see Figure 4.1) to function as the primary means for understanding the major functions of network management systems (Cisco, 2007).

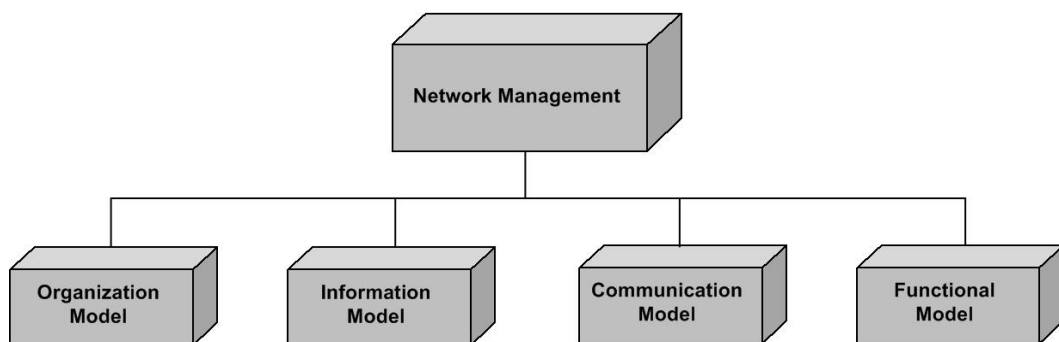

*Figure 4.1 OSI Network Management Architecture Model*

The OSI/ISO Network Management Model is the most superior of all the other existing models, it is structured and it addresses all aspects of management (Subramanian, 2000). The OSI/ISO Network Management Model comprises four models, the organization model, information model, communication model and functional model.

This thesis focuses on the NM Functional and Organization Models. This two protocol independent architectures can provide the flexibility to adapt to similar NM information systems as it is in this case a WSN healthcare monitoring application. The NM Functional Model embraces the main modularized processes utilized in the functionality of any NM system, furthermore the researcher utilized the Organization Model to categorize and describe the components of the proposed system and their relationships. Details are set out in Section 4.6 and 4.7.

The appearance and level of detail of the NM Organizational and NM Functional models form the underpinning theory for the thesis. The NM Organization Model is described first at its conceptual level followed by a description of its intrinsic relationships and further adaptations for this thesis. Later on this chapter, the NM Functional Model description, relationships and adaptations to the MoteCare systems will be presented in detail.

### 4.6 Network Management Organizational Model

The NM Organization Model describes ways in which OSI Management can be distributed administratively across management domains and management systems within a domain (Klerer, 1988). The NM Organizational Model describes the components of network management and their relationships. Network objects consist of network elements such as hosts, hubs, switches, and routers among others. These objects can be classified as managed and unmanaged



objects or elements. The managed objects have a management process running in them called an agent. These agents first collect and/or collate information about the managed devices in which they reside, then store this information in a management database, and finally provide this information (proactively or reactively) to the management entities within the network management system (NMS) via a network management protocol. Well-known network management protocols include the Simple Network Management Protocol (Mauro and Schmidt, 2001) and Common Management Information Protocol (CMIP).

The manager manages the managed elements. Management entities are either triggered by a trap coming from an agent, or by filtering and applying certain rules to the polled data from the various devices. These management entities are programmed to react to these alarms by executing one, several, or a group of actions, including operator notification, event logging, system shutdown, and automatic attempts at system repair (Lewis, 2005). In the proposed healthcare monitoring system an alarm could sound in the medical carer's room if a remotely monitored elderly person's blood pressure started to rise above normal limits, for example.

In the Two-Tier NM Organizational model there are two types of entities, the manager and the agent. The manager queries the agent for information, processes it and stores it in its database (see Figure 4.2).

#### 4. NETWORK MANAGEMENT APPROACH

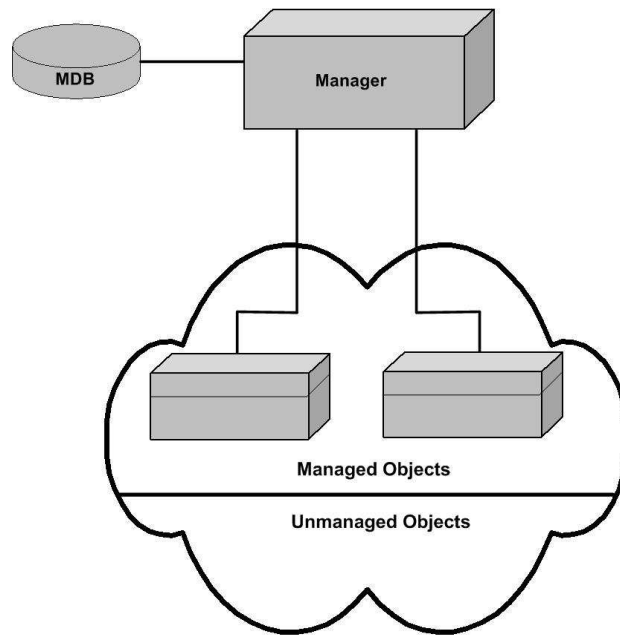

*Figure 4.2 Two-Tier Network Management Organization Models  
(Subramanian, 2000)*

In contrast, the Three-Tier Organizational model contains three elements, the manager, the agent and an intermediate entity that can act as a manager to manage the agent below or as an agent to send information to the manager entity on top. In this model, there are two databases; one that belongs to the manager and the second one to the intermediate agent/manager (see Figure 4.3).

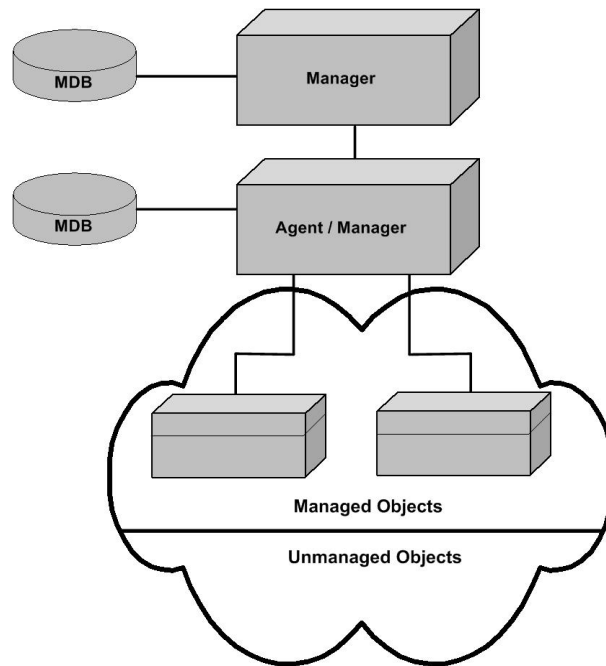

Figure 4.3 Three-Tier Network Management Organization Models  
(Subramanian, 2000)

## 4.7 Adopted Layered NM Organization Models to MoteCare Systems

In the health monitoring system the managed objects will be the deployed Wireless Sensor nodes located on either the human body or in the environment. Instead of merely polling information regarding the management of such networked nodes, the author utilizes this model for the organization and polling of the collected health/sensor data nodes in the prototyped Personal Health Care Monitoring system of this project, namely MoteCare systems.

As mentioned in the first chapter, most of the wireless sensor nodes utilized for this work are MICA2 and MicaZ Motes, tiny sensors developed by Berkeley. The previous chapter (Chapter 3) contains the full specifications and more information about these devices. Due to some inherent characteristics of most current wireless sensor network

technologies, some important changes in this proposed model were made. For instance, in order to overcome the limitations of the sensor nodes to communicate through the NM standard communication protocols such as Simple Network Management Protocol (SNMP) (Mauro and Schmidt, 2001), the researcher built a script based on the Agent Server Organization model structure (Figure 4.4) on the first three MoteCare systems to inject the collected data on behalf of the absent mote-SNMP-agent into the selected NM managing systems (see Chapter 6). The use of a tailored SNMP proxy agent to communicate to the managed devices was subsequently used in the Medical MoteCare system (see Chapter 9).

## 4.8 SNMP

Cromer (2000) states that Simple Network Management Protocol (SNMP) is the TCP/IP standard for network management. It was introduced in 1988 to meet the growing need for a standard for managing Internet Protocol (IP) devices. SNMP provides its users with a "simple" set of operations that allows these devices to be managed remotely (Mauro and Schmidt, 2005). Network devices can be monitored by querying them over SNMP. Those devices will then answer to the queries with the appropriate answer. Queries can be generated by a large number of management tools. Management tools at the same time can also visualize the data transferred over SNMP. SNMP is a device independent standard to manage devices in a network. It allows multiple managers to talk to multiple devices (agents) (Fischer, 2008). Table 4.2 outlines the components of a SNMP management System.

*Table 4.1 Components of an SNMP Management System  
(<http://tools.ietf.org/html/rfc3411>)*

- Several (potentially many) nodes, each with an SNMP entity containing command responder and notification originator applications, which have access to management instrumentation (traditionally called agents);
- At least one SNMP entity containing command generator and/or notification receiver applications (traditionally called a manager) and a management protocol, used to convey management information between the SNMP entities;
- SNMP entities executing command generator and notification receiver applications monitor and control managed elements. Managed elements are devices such as hosts, routers, terminal servers, etc., which are monitored and controlled via access to their management information.

SNMP uses the management information term to refer to the operational parameters provided by SNMP-capable devices. The representation of this information is based on the Structure of Management Information (SMI) versions 1 (RFC 1155) and version 2 (RFC 2578). The definition of Managed Objects shown in Two-Tier and Three-Tier Organizational models in Figures 4.2 and 4.3 respectively can be broken down into three attributes, the Name or Object Identifier (OID) uniquely defines a managed object, the Type and syntax that uses a subset of Abstract Syntax Notation One (ASN.1) to specify the representation and transmission of the data between managers and agents within an SNMP platform independent context, and at last, the Encoding which is a single instance of a managed object encoded into a string of octets using the Basic Encoding Rules (BER). BER defines the encoding and decoding of the objects so they can be transmitted over a transport medium such as Ethernet (Mauro and Schmidt, 2005).

Because WSNs are at an early stage of development with a lack of international standards among various WSN manufacturers, the researcher had to utilize the WS "proprietary" communication protocol

and an additional agent entity for the prototyping of the first three MoteCare systems and experiments. In order to address these limitations within the same OSI/ISO organization structure, the researcher incorporated the Agent Server Organization Model (see Figure 4.4) in MoteCare, Mobile MoteCare and Stargate MoteCare systems within the Three-Tier NM Organization Model to allow Non-SNMP Managed objects communication with the Manager. However the Medical MoteCare prototype developed in late 2007 used an SNMP proxy agent and will be fully described in Chapter 9. Management proxies (Cisco, 2006) are entities that provide management information on behalf of other entities.

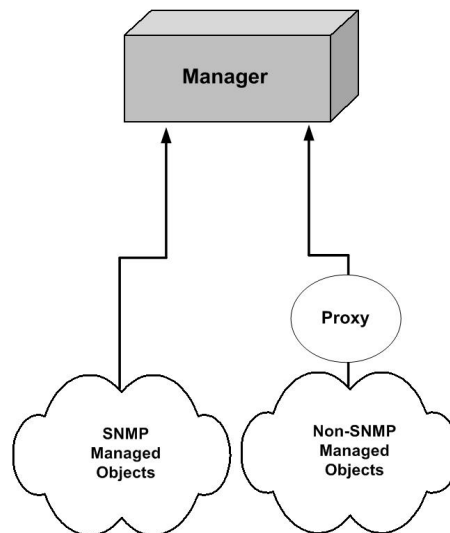

*Figure 4.4 Agent Server Organizational Model (Subramanian, 2000)*

In the case of the MoteCare systems such Non-SNMP entities are the motes, and the Agent entity is either a script-type of object or an SNMP agent (in the case of the Medical MoteCare system) that act as SNMP translators to communicate with the Manager of the Two-Tier and Three-Tier NM Organizational models; such an adaptation is shown in Figure 4.5 below.

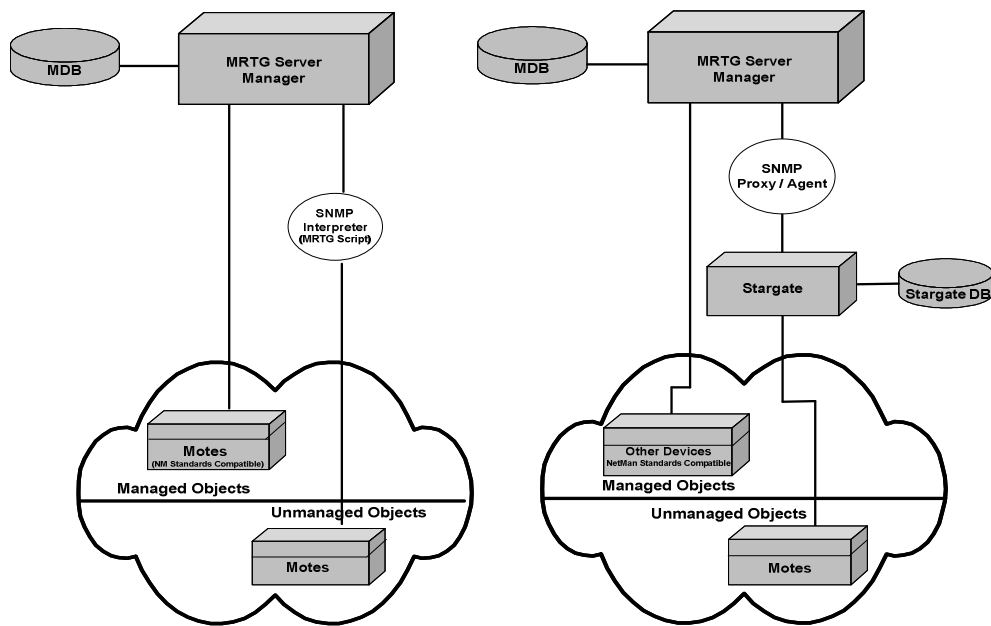

Figure 4.5 Adapted Two-Tier and Three-Tier NM Organizational Models to the Stargate MoteCare and Medical MoteCare Systems

An important variation in the adapted Three-Tier NM Organization model (right diagram on Figure 4.5) is the database structure of the middle management or agent entity. This database is native to the WSN Stargate middle management entity, and not of an SNMP management information nature as in the original Three-Tier NM Organization model presented in Figure 4.3. This maintains simplicity in the MoteCare systems communication with the SNMP Proxy / Agent entity by still allowing the use of one SNMP proxy agent per NM Manager.

The adaptation of the Three-Tier NM Organization model allowed the researcher to reduce the memory and processing power used by the sensor nodes from buffering. This adaptation was required because the motes have limited storage and processing capabilities (see Figure 4.5). Furthermore this model also allows for a distributed environment with more than one Manager or Middle Manager/Agent entities (see

Figure 4.4) without adding any processing burden to the sensor nodes from redundant continuous polling.

## 4.9 Network Management Functional Model

The Network Management Functional Model is the primary means for understanding the major functions of network management systems. This model consists of five conceptual areas discussed in the following sections (see Figure 4.6). These five conceptual areas are extended with an explanation of their proposed functionality in a generic WSN Application for Personal Health Care purposes. The author concentrated on Performance and Fault management for the building of the prototypes.

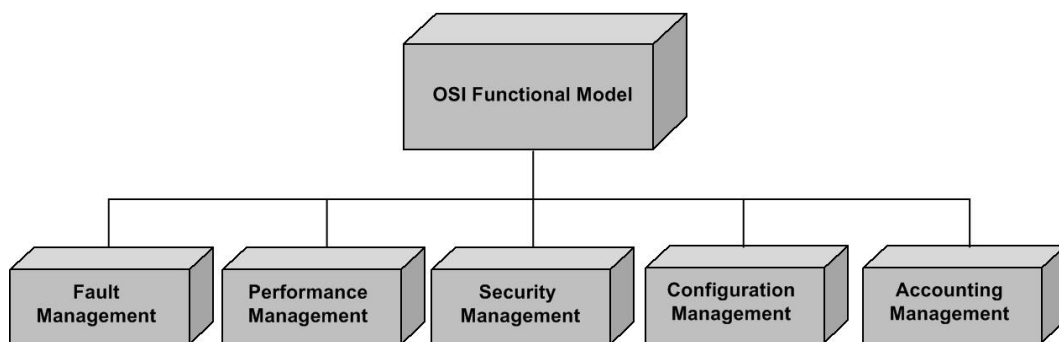

*Figure 4.6 Network Management Functional Model (Fiedler, 2004)*

A detailed analysis of the five functional areas was undertaken and considered for its development and implementation according to its relevance to WSN Personal Health Care monitoring system. The deployed systems have been named MoteCare to simplify the reading of this document.



Short definitions are contained in Table 4.3.

*Table 4.2 Definitions of OSI Functional Model  
(Klerer, 1988; Lewis, 2005)*

Management Item	Description
Fault	to detect, log, notify users and, whenever possible, to automatically correct abnormal network operations to keep the network running effectively
Performance	to measure and make available various aspects of network performance so that it can be maintained to an acceptable level. Performance variables such as network throughput, and user response times may be measured
Security	to control access to network resources to ensure that sensitive information cannot be accessed by those without appropriate authorization
Configuration	to monitor network and system configuration information so that the effects on network operation of various versions of hardware and software elements can be tracked and managed
Accounting	to measure network utilization parameters so that individual or group users on the network can be regulated appropriately

#### 4.9.1 Fault Management

The main objective of *fault management* is to detect, isolate, log, notify users and, whenever possible, to automatically correct abnormal network operations to keep the network running effectively (Klerer, 1988). Because faults can cause downtime or unacceptable network degradation, fault management is the most widely implemented of the ISO network management subsystems (Lewis, 2005). Fault management involves first determining symptoms and isolating the problem. The problem must be corrected by the software or the

network manager and the solution tested on all important subsystems. Finally, the detection and resolution of the problem is recorded (Lewis, 2005). In the MoteCare health scenario if the system or a carer detects that that temperature of the patient is steadily rising, an alarm sounds to alert the medical staff to this problem so that action can be taken immediately. Besides the medical aspect, fault management for the WSN has also to be considered. Failure of network nodes due to dead batteries could be prevented by monitoring the power level and by replacing the batteries before they fail.

#### **4.9.2 Performance Management**

The objective of performance management is to measure and make available various aspects of network performance so that it can be maintained to an acceptable level. Performance variables such as network throughput, and user response times may be measured (Lewis, 2005). For the purposes of this research study Performance Management variables are intended to monitor and measure variables that can be indicative of the status or evolution of a specific health condition or illness over time. In the first three MoteCare systems the researcher monitored and measured environmental variables such as light and room temperature, adding medical sensors, namely Pulse Oximeters, in the last developed Medical MoteCare further described in Chapter 9.

The OSI Network Management functional model's Performance Management involves three main steps:

- a) performance data is gathered on variables of interest to network administrators;
- b) this data is analysed to determine normal (baseline) levels;

- c) lastly appropriate performance thresholds are determined for each important variable so that exceeding these thresholds indicates a network problem worthy of attention (Cisco, 2006).

Based on this model, the MoteCare project aims to collect and measure health indicative variables of interest to the medical practitioner or caregiver. Management entities, such as health providers and caregivers, will continually monitor performance variables. When a performance threshold is exceeded, an alert will be generated and sent to the doctor, caregiver or relatives of the patient. Details of the way the researcher implemented the above will be explained in Chapters 6, 7 and 8 which describe the MoteCare systems.

Each of the steps just described is part of the process to set up a reactive system. When performance becomes unacceptable because of an exceeded threshold, or a series of them, the system reacts by sending a message or notification. Performance management also permits proactive methods: For example, network simulation can be used to project how network growth will affect performance metrics. Such simulation can alert administrators to impending problems so that counteractive measures can be taken.

The alerting and/or preventing of potential dangerous environmental variables for patients with specific illnesses, the elderly, or patients in recovering phases from surgery, that could fall into health threatening situations in specific environmental conditions, could also be considered proactive performance management. One example would be for a patient suffering from heat stroke – if the surrounding environmental temperature increased dramatically such a person would be placed in danger so an alarm would sound in the care giver's room to alert the healthcare giver.

In the same manner, proactive performance management in a Personal Health Care System could allow doctors or carers to predict and avoid undesirable health conditions in patients by analysing previous personalized statistical data, either from its management database with previous historical measurements, or by accessing and comparing existing external knowledge base systems from reliable medical sources. This aspect of the MoteCare systems fulfils the objective to make the system context aware, as stated in Chapter 1.

### **4.9.3 Security Management**

The objectives of a security management subsystem are to control access to network resources to ensure that sensitive information cannot be accessed by those without appropriate authorization. Security management subsystems perform several functions that need to be applied in a WSN Personal Healthcare monitoring system. As an example this type of subsystem is able to identify the location of sensitive information and determine its secure access by mapping the sensitive information or resources and users. A security management subsystem can also monitor access points to sensitive network resources and log and prevent inappropriate access to the system. The specific issues that relate to security issues were outlined in Chapter 3 in the section entitled 3.3 Technical Advantages and Disadvantages.

Some of the issues that are outlined in Table 4.4 illustrate the specific types of security issues that are associated with Wireless Sensor Networks. All of them would prove potentially disastrous in a medical or healthcare setting where privacy must be protected.

Table 4.3 Security Threats to Wireless Sensor Networks (Avancho, 2006)

Type of Threat	Example
Passive Information Gathering	If communications between nodes or collection points are in clear text, hackers with receivers and antennae could intercept the data stream.
Subversion of a Node	The small devices can be easily picked up, tampered with, electronically interrogated and potentially comprised.
Addition of False Nodes	Hacker could insert a rogue node into the systems and send false data or block real data.
Node Malfunction	It is often difficult to track these malfunctions so nodes might be sending inaccurate data.
Node Outage	Alternate routes must be robust enough to reroute around the non functioning node.
Message Corruption	Hacker could potentially insert node to modify the contents of a message between the source and destination node.
Denial of Service	Could jam the radio link, exhaust the resources or misroute the data.
Traffic Analysis	Even if the data is encrypted expert analysis of the communication patterns and sensor activity might give away enough information for someone to subvert the mission of the WSN

Security measurements were incrementally added in the various series of MoteCare systems. The MoteCare, Mobile MoteCare and Stargate MoteCare systems s included an authenticating method the users when accessing the monitored data via the handheld device or remotely through the use of web interface of the implemented Network Management server. Furthermore the MoteCare Medical prototype incorporated the use of version 3 SNMP security features such as the authentication and encryption to the secure polling of the data thorough the LAN and WAN networks.

The use of the security management subsystem of Network management tools should assist in securing the vital medical

information that is being monitored by the MoteCare system. However, as mentioned earlier, the security setup for the MoteCare systems would be considered insufficiently robust for a health monitoring environment and will require further research which is outside the present scope of this thesis.

#### **4.9.4 Configuration Management**

The goal of configuration management is to monitor network and system configuration information so that the effects on network operation of various versions of hardware and software elements can be tracked and managed (Lewis, 2005). The area of configuration management in the adapted model is intended to keep track and associate health records and relevant personal information with each monitored patient or user. Configuration management subsystems store this information in a database for easy access, so then when an alarm is triggered this database can be searched to aid the caregiver or medical practitioner to access in a timely manner the personal health records of the patient in question. As mentioned in Chapter 1 (and further developed in Chapters 7 and 8) the author used the Multi Router Traffic Grapher (MRTG, 2007), an open source Network management tool for configuration management for the MoteCare, Mobile MoteCare and Stargate MoteCare systems . The choice of MRTG as an open source tool was made for the following reasons:

- compression of the data with an effective algorithm to define trends via averaging as will be demonstrated in Chapters 6 and 7 during the discussion of the development of MoteCare ;
- it was freely available from the web;
- it had been used effectively by Network managers for over a decade and therefore was essentially an effective NM tool as a result of this continual testing and updating by the inventor and a

global team of network managers who contributed to its robust and stable operation;

- it was able to provide this researcher with essential functions by gathering data and visualising and consolidating the collected data for the testing of the prototypes.

#### **4.9.5 Accounting Management**

The goal of *accounting management* is to measure network utilization parameters so that individual or group users on the network can be regulated appropriately. Such regulation minimizes network problems (because network resources can be apportioned based on resource capacities) and maximizes the fairness of network access across all users (Lewis, 2005). As with performance management, the first step toward appropriate accounting management is to measure utilization of all important network resources. Analysis of the results provides insight into current usage patterns, and usage quotas can be set at this point. Some correction, of course, will be required to reach optimal access practices. From this point, ongoing measurement of resource use can yield billing information as well as information used to assess continued fair and optimal resource utilization. Accounting Management can measure network utilization of the various sensor nodes, so that a sensor or a group of sensors can be prioritized or managed in a manner that can guarantee enough bandwidth and appropriate use of resources in the event of an alarm, and/or in other changes in traffic utilization. Accounting Management features in MoteCare can be also useful when MoteCare capabilities are extended to monitor multiple users. However it must be pointed out that application requirements play a part in determining the level of service required when dealing with Wireless Sensor Motes, for example a time based scheme for node self scheduling applications (Perillo, 2006).

Accounting Management in the Network Management Functional Model is an important aspect which is outside the scope of this thesis.

#### **4.9.6 Event Correlation Techniques**

Other network management techniques that could be usefully employed in a health monitoring system include Event Correlation Techniques. Event correlation techniques are mainly utilized in Fault Management and Performance management subsystems to identify the presence of undesirable behaviours by correlating events, messages or alarms and prioritizing them. Some of these techniques will be explained in this section.

Event correlation techniques embedded in various network management tools allow for the development of personalized applications, specific to certain health conditions. Current techniques such as Rule-based reasoning (RBR), Code-based reasoning (CBR) and Case-based reasoning (Subramanian, 2000) are utilized to add intelligence to Network Management Systems (NMS) and tools by correlating events and prioritizing them based on thresholds for labelling, various algorithms and hierarchical structures associated with them. For instance if some "events" in the system are triggered at the same time, e.g. temperature of the person and temperature on the environment, the system will check correlation and prioritize in order to trigger an alarm/message/action.

Fault management is the most relevant functional area for a Personal Health Care monitoring system, as it is the functional subsystem that can not only detect undesirable symptoms in the monitored patient, but it could alert the nurse, medical practitioner or relatives in case of an emergency event. It could even be automated to set up alarms or



trigger the calling of an ambulance or even dialling 000 (the Australian Emergency number) in extreme cases.

#### 4.10 Implementing Network Management Tools and Techniques in the MoteCare Project

As a result of this analysis, three functional areas were considered to be crucial in the building of MoteCare, namely Fault Management, Performance Management and Security Management. The work covered by this research project is mainly focused on Fault and Performance Management. Some features in the Security Management subsystem were implemented in the Medical MoteCare system as a result of using SNMP v3. The earlier MoteCare systems did not feature full secure access to the information. A holistic and complete security policy for the system has to be designed and implemented, as the MoteCare systems could potentially contain sensitive personal information. Such a security system is outside the scope of this research.

The remaining two functional areas of this model namely Configuration and Accounting Management subsystems won't be covered, as these represent additional features to the system. Although, Configuration and Accounting Management in personal healthcare monitoring environments are directions for future research as they can be implemented to manage personalised medical patient records (Configuration Management) and used for billing purposes on ubiquitous distributed personal health monitoring services (Accounting Management).

#### 4.10.1 NM and MoteCare System Requirements

Network Management tools and techniques based on the previously explained NMS models and architectures have been developed to address specific technical challenges in the deployment of an NMS (refer to Figure 4.7), and are primarily identified as the following (Subramanian, 2000):

- managing numerous devices;
- extracting vast amounts of data from the monitoring of the environment and people;
- managing and storing this data;
- dealing with continuous monitoring (Always ON - Always Aware);
- being self-healing whenever possible;
- ensuring security –Authentication, Authorization and Accounting (AAA);
  - authentication provides a way of identifying a user, typically by having the user enter a valid user name and valid password before access is granted;
  - authorization is the process of enforcing policies: determining what types or qualities of activities, resources, or services a user is permitted;
  - accounting refers to logging of session statistics and usage information and is used for authorization control, billing, trend analysis, resource utilization, and capacity planning activities;
- guaranteeing reliability;
- coping with the diverse nature of the information gather by different sensors;
- manipulating the data (Data Collection to Data Fusion);
- standardizing data for communication and interaction (Subramanian, 2000).

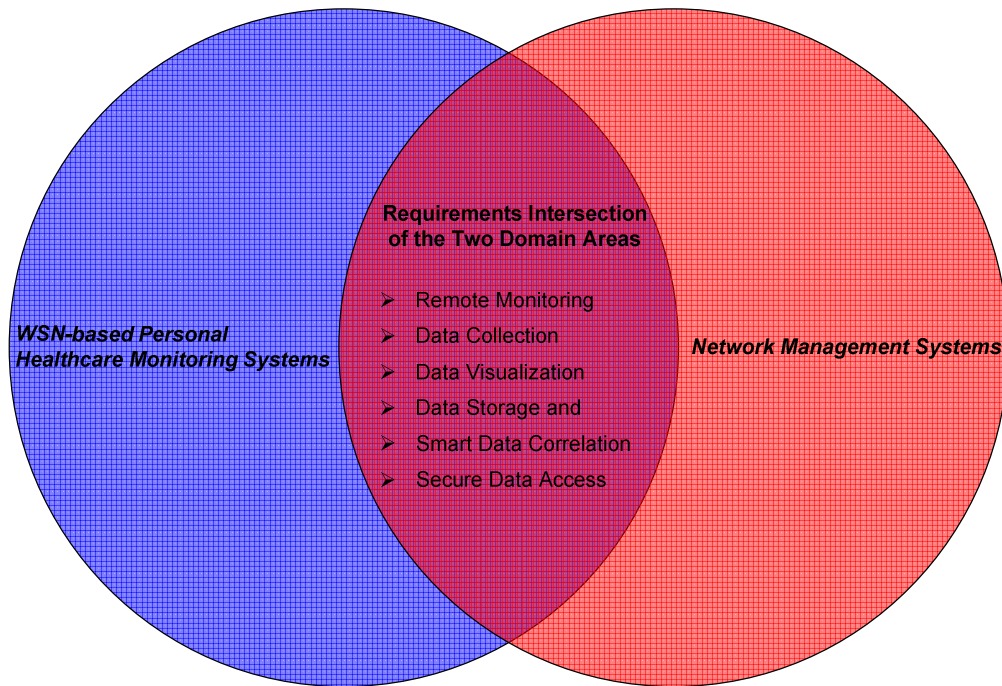

*Figure 4.7 Network Management Systems and a WSN Personal Healthcare Monitoring Systems Intersection*

Some NM tools and techniques further explained in this chapter were used to develop the MoteCare systems in order to collect and store relevant data, provide timely information and alert and sometimes anticipate problems in a personal healthcare monitoring system.

In the case of patients with chronic illnesses which require continuous monitoring, MoteCare was also developed with the purpose of enhancing their quality of living by utilizing the remote monitoring MoteCare feature, which allows the patients or users to still be constantly monitored on a mobile environment.

The network management tool selected to develop some of the monitoring features of the Motecare, Mobile Motecare and Stargate MoteCare systems included the use of Multi Router Grapher (MRTG), an open source network management tool capable of collecting, storing, formatting, sharing and presenting the information graphically

through a user friendly web based interface. MRTG is a Network Management tool normally utilized to monitor the traffic load on network links. MRTG generates HTML pages containing Portable Network Graphics (PNG) images that provide a visual representation close to real time of the inbound and outbound data traffic of the monitored devices. MRTG is written in Perl and C and works under UNIX and Windows platforms. MRTG is being successfully used on many sites on the Internet (Oetiker, 2005). The basic operation of MRTG is based on Simple Network Management Protocol (Mauro and Schmidt, 2001) which is the "de-facto" standard protocol for internet-work management, and includes a limited set of commands and responses to a Management Information Base (MIB), hierarchical information, structured as a "tree". MIB is a way to present information and in MRTG uses the information provided by SNMP to obtain graphics of the different parameters contained in the MIB, such received/transmitted packets, discarded packets, CPU usage, amount of free memory and data rate. The issue, however, is that Motes do not utilize MIB so therefore the researcher used the Agent Server Organization Model by the use of a script as an additional entity to overcome the lack of an SNMP agent in the sensor nodes. A more detailed description of the script and its functionality will be further discussed in Chapters 6 and 7 describing the prototypes. The flexibility to be able to manage non-SNMP objects by deploying user-developed scripts is one of the most significant advantages of MRTG. This NM tool allows for expandability and adaptability in the configuration to monitor not only traffic and SNMP variables, but to also monitor non-SNMP devices and to even import data from an external application.

In order to avoid the storing of incredible amounts of data obtained from the continuous monitoring of thousand of sensor nodes (or network devices), MRTG uses a consolidation algorithm that maintains an accumulated database. MRTG also permitted MoteCare four levels

of detail for every entity monitored: data measurements in the last twenty-four (24) hours, the last week, the last month and a yearly graphic.

Some of the limitations of MRTG were the dropping in the level of detail of the records as the data becomes older and therefore compressed and consolidated in the database. So, the use of an additional structured database was added to MoteCare, as well as the additional programmable ability to “react” to set thresholds. As mentioned earlier, Medical MoteCare used an SMNP proxy, modified CodeBlue software and proprietary NM software to provide the level of sophistication required. The advantages and disadvantages of each of the Motecare systems are addressed in Chapters 6, 7 and 8.

## 4.11 Conclusion

This chapter explained the role of Network Management Models and Techniques and their applicability to the development of a WSN Personal Healthcare application. Network Management concepts and techniques including the ISO OSI Model as well as Network Management architectures were explained. The emphasis in this thesis is on Fault and Performance Management. The author outlined how an adapted Network management architecture and tools such as MRTG are used to provide the first three MoteCare applications with the basic infrastructure for data collection, storing, formatting, and accessing of bio and environmental signals in almost real time. The MoteCare systems also apply NMS compression techniques of the stored information up to two years of historical data. It also offers a feasible method for publishing in a website in a graphical form health and environment parameters through a user friendly web interface. In the Medical Motecare health monitoring application the author used pulse oximeters for measuring heart rate and blood oxygen levels, an SNMP

proxy and a variety of modified proprietary NM tools which will be described in Chapter 8.

The following chapter will outline the different user interfaces that have been investigated for MoteCare, including Brain Computer Interfaces (BCIs), Personal Digital Assistants (PDAs), laptops and mobile phones. Chapters 6, 7 and 8 will describe and discuss the MoteCare systems.

# 5. Interfaces for the MoteCare Health Monitoring Systems

*The more we learn, and the more we translate that learning into new products and new people- centred systems, the more likely it is that we can meet our shared ambitions for safe, more efficient and more effective healthcare in this new century (Tobias, 2007).*

## 5.1 Introduction

User interfaces for healthcare monitoring systems are a very important element to consider as they represent the only channel for the user to interact with the system. Potentially they could be the most likely point(s) of failure in any developed healthcare monitoring system even when the rest of the elements perform as expected. This is the reason why this thesis will devote a chapter into the investigation and analysis of the various current commodity mobile interfaces that were considered for the MoteCare proof of concept systems of this research project. Interfacing hardware in mobile computing include laptops, Personal Digital Assistants (PDAs) or handheld devices, mobile phones, and smart phones that combine integrating communication features with combined functionality (Hameed, 2003). In the nascent wireless environment, the technology platform is far more complex. There are a vast array of devices in the marketplace, and competing platform standards (Ziv, 2005). These devices are investigated in this chapter

and the researcher describes why Laptops and PDAs were the interfaces of choice. These choices are based on the Stages of Growth Theory (Gibson, 1974) as well as the Modification and Extension Model for Prototyping (Kranz, 2006).

The integration of mobile computing, more specifically wireless mobile interfaces into the medical and health care fields have resulted in new areas of research called Mobile Health or mHealth. The increasing interest in this emerging area is attributed to several factors, including:

- the evolution of the Information Society to the mobile information society (Akihisa Kodate, 2003);
- the increasing growth of medical expenditure in relation to Gross Domestic Product in countries such as United States, Germany, Japan and France (as outlined in Chapter 2) (OECD, 2001);
- the increase in the aging population (over 65 years old) (United Nations) (ITU/MIC, 4-5 March 2004) as well as the increase in the number of chronically ill, the infirm and the obese who suffer from a variety of health threatening conditions as outlined in Chapter 2 of this thesis.

This last point is important because mobile devices such as smart phones and PDAs are traditionally popular with the younger generation and not with the persons in the elderly or infirm demographic. The latter would be candidates to use mobile health monitoring systems such as the ones developed in the MoteCare proof of concept prototypes so obviously the design must take the above into account. Thus, in this chapter, the author explains the principles behind effective interface design which informed the work that was developed for the MoteCare systems.



## 5.2 User Interface Design Overview

Raskin's 1st Law of User Interface Design states:

- a computer shall not harm your work, or, through inactivity, allow your work to come to harm (Raskin, 2000);

while Raskin's 2nd Law of User Interface Design states:

- a computer shall not waste your time or require you to do more work than is strictly necessary.

During the design of a remote healthcare monitoring system for the elderly, infirm and ill, the researcher kept the above two laws in the forefront of the selection process especially as the proof of concept MoteCare systems are using commodity based wireless sensor networks which are in an early stage of development and have limited power, as explained in Chapter 3.

In the following sections a general review of the current mobile interface technology applied in the various medical or health monitoring applications is presented. A description of the more specialized field of wireless wearable computing interfacing and its situation and interactions with the medical and health care applications is then analysed.

## 5.3 Interfaces Evaluation Overview

The mobility axis that wireless sensors can bring into the health monitoring applications opens up a new set of possibilities in the areas of health problem prevention, remote care and professional assistance, out-of-hospital patient recovery and quality of life enhancement for

patients with chronic diseases. However, at the same time, such mobile and ubiquitous monitoring environments signify a quite demanding arena for user computer interface technologies. Such interfaces need to be as transparent and easy-to-use as possible, as in some cases mobile users/patients might have to be monitored constantly without making this interfacing device a burden in their daily activities. In a similar manner, as the users can be patients with permanent or temporal disabilities due to their current health situation, the interface has to be intuitively easy to use – and sometimes multimodal, and/or adapted to the special needs of the user. Multimodal refers to a variety of ways to interact with the computer – for example, keyboard, mouse, pen, voice, touch screen and speech recognition (Ringland, 2003).

Mobile user requirements represent not only high demands from the technical viewpoint but, in some cases, even conflict with each other. Mobile applications might require a small easy-to-use interface whereas complex multimedia applications, that require high processing power, may not be suitable on small interfaces (Ringland, 2003).

*"The mobile environment presents some unique challenges for data applications not seen in the traditional PC world, centring on the user interface... For mobile data applications to succeed, they must overcome the challenges of the mobile environment" (Ringland, 2003).*

On top of this scenario, specific health monitoring application requirements need be considered, as the continuous polling, and amount of data obtained in a health monitoring application demands more memory or power processing to store and/or filter such information. It should be in a graphical or multimedia format for ease of understanding by the user, in this case a clinician or a healthcare giver such as nurse or a relative.

## 5.4 Mobile Medical Application Interfaces

In this section the researcher reviews and discusses the various interfaces that so far have been used in other medical or health monitoring applications so that the author could evaluate the potential benefits and weaknesses of the interfaces before developing the MoteCare systems.

For this interfaces review, the *Modification and Extension of Consumer Devices for Prototyping* approach was used. This approach argues that the modification and extension of existing commercially off-the-shelf systems for deriving research prototypes in scenarios where connecting the interface to a network is essential (Kranz, 2006),

*The resulting systems consist of already well-designed building blocks, contributing to improved utility and usability of the overall to-be-built system. They lower the overall time and cost of such systems giving way for more deployed installations in the real world. (Kranz, 2006)*

Features such as connectivity, open standards, and cost are of critical importance in the design of the MoteCare system. The use of this approach when evaluating the various user interfaces for prototyping was also essential for the development of the final framework. Table 5.1 sets out typical mobile technology applications and describes their benefits.

*Table 5.1 Example Applications of Mobile Computing to Primary Health Care (Hameed, 2003)*

Mobile Technology Applications	Benefits
The use of mobile terminals by primary health care (PHC) workers at points of service provision (on or off-site)	<ul style="list-style-type: none"> <li>▪ Effective portability and usage of electronic patient records and history to improve the quality of contact.</li> <li>▪ Data capture using standard formats and templates, with a local electronic knowledge base to guide data entry, enhancing the quality and accuracy of the captured data.</li> </ul>
Remote mobile access to information services for primary health care workers	<ul style="list-style-type: none"> <li>▪ Access to common and consistent decision support systems to enable the best diagnosis, ensuring consistently high standards.</li> <li>▪ Enhanced support for distributed and remote electronic learning across a range of personnel using multi-media resources.</li> <li>▪ Effective dissemination of information pertaining to good practice.</li> </ul>
Transmission of data from remote locations to a central system using mobile communications technology	<ul style="list-style-type: none"> <li>▪ Immediate transfer and integration of patient information into the information system thereby ensuring the integrity of complete patient information and improving co-ordination between PHC teams.</li> </ul>
Mobile portals for information access	<ul style="list-style-type: none"> <li>▪ Patient access to National Health Service (NHS) information services for self-care, irrespective of time or location.</li> </ul>
The use of mobile devices by patients	<ul style="list-style-type: none"> <li>▪ Facilitation of telecare and telemedicine allowing the remote capture of data (e.g. periodic remote monitoring of blood pressure)</li> </ul>

### 5.4.1 Stages of Growth Framework

Mobile and wireless technologies have been located within the framework of Gibson and Nolan (Gibson et al, 1974) (see Figure 5.1). Such a framework was originally utilized to describe the growth and spread of information systems in organizations. This approach applied by (Ooi et al, 2005) helped the author to relate the interfaces from their pure technical nature, to the next level of interface usability and user technology adoption by identifying their level of permeation (or stages of growth) into the different medical technology application areas.

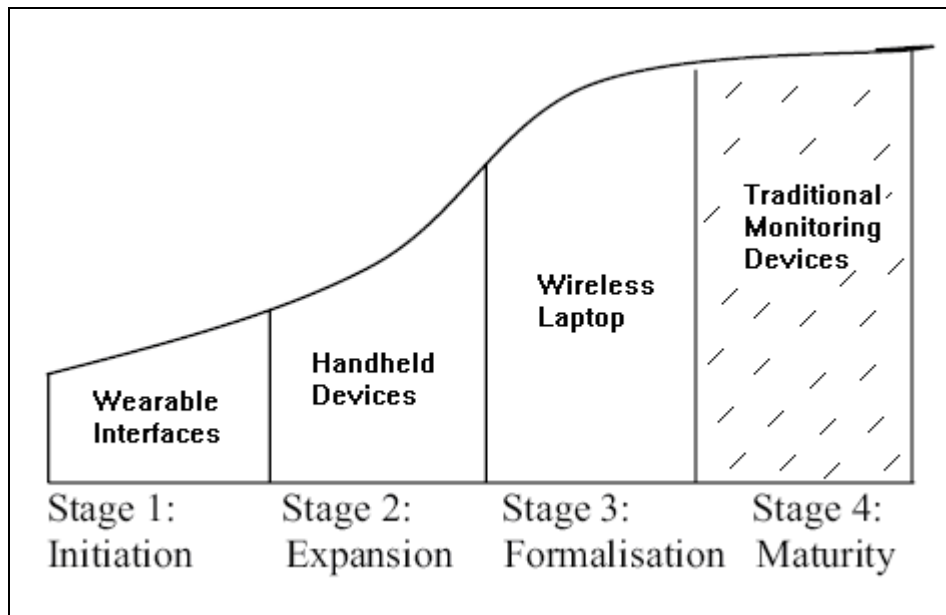

*Figure 5.1 Wireless Application Interfacing Categories mapped to Gibson and Nolan Stages of Growth Framework (Ooi et al, 2005)*

In the Initiation Stage (Stage 1) the technology is introduced into the organization for simple functions, usually with a short term focus. This is commonly for the purpose of short-term immediate cost savings. (Ooi et al, 2005) At the Expansion Stage (Stage 2), new projects are undertaken and expenditure rises abruptly. Gibson and Nolan (1974)

state, "it is a period of contagious, unplanned growth". At the Formalization Stage (Stage 3), systems are prescribed and management attempts to control costs in order to stop expanding expenditure. It marks the end of Stages 1 and 2, which are aimed at reducing general and administrative costs; it marks the start of the time for real profits. Maturity (Stage 4) signifies continuing economic benefit where the needs for updates are recognised. Applications play a key role and the focus shifts to software rather than hardware developments (Ooi et al, 2005).

Results from this research show the levels of growth for wireless devices used in medical applications were considered to be in their Formalisation stage, whereas the wireless PDAs for information access and exchange were considered to be into their Expansion stage (Fig. 5.1). The use of wireless laptops and PDAs indicates a feasible choice to integrate into the development of the MoteCare systems. These commodity based technologies offer stability and reliability, important characteristics for health care applications. Furthermore, from a healthcare organization's point of view these existing devices provide a more encouraging environment for further planning, cost control and quality assurance.

#### **5.4.2 Wearable Interfaces**

Ooi et al (2005) state that wearable computer systems will be equipped with special sensors, pattern recognition tools and signal processing tools to collect vital signals (Ooi, 2005).

Table 5.2 outlines some of the advances made in this area.

Table 5.2 Wearable Computing (Ooi et al, 2005)

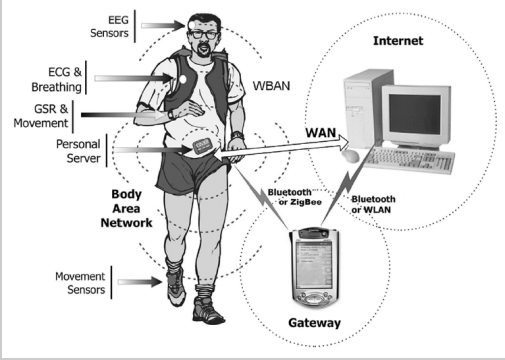
Examples	Reference	Illustration
<p>Belts, glasses, clothing and blankets.</p> <p>Wearable vest Sensatex measures heart rate, respiration and body temperature. All are then calibrated and relayed in real time for analysis.</p>	<p>(Mizrachi, 2000) (Sensatex)</p>	
<p>Body Area Networks (Babiloni, 2000) consist of devices such as vital sign sensors, microphones and cameras provides a solution to current innovation in healthcare by improving the time to treatment and distributed healthcare processes.</p>	<p>(Istepanian, 2003) (Widya, 2001)</p>	

For wearable interfaces the desirable system requirements include:

- a) context awareness;
- b) transparency for the user;
- c) ubiquitous / smart multimodal connectivity;
- d) allowance for distributed computing features;
- e) ability to perform data processing and filtering.

The major obstacles to wider use of intelligent wearable medical monitors include size and weight of the monitor, sensor implementation and connectivity (Raskovic, 2004). Monitoring people's health using mobile computing and wearable devices is also a sensitive

area as personal and private information is being recorded and kept. The information may prove frightening or upsetting to a patient, the patient may not be sufficiently able cope with handling the device, the device might have small screen real estate causing difficulties for the user to read and interpret the information, or even the device itself may have the potential to interfere with other medical devices in the vicinity of the wearer.

According to (Ooi, 2005) wearable computers or BAN interfaces fell into the Initiation stages of growth within organizations with medical usage applications. This situation does not necessarily mean an abrupt end to integrating them into medical or health care applications. On the contrary, according to medical and mobile computing research bodies (Raskovic, 2004) (Hameed, 2003) (Pentland, 2004) a vast range of new possibilities exists for incorporating them into medical and healthcare applications in the present and the future;

*Medical monitoring applications for wearable computing offer a powerful new way to keep track of a patient's medical condition and predict impending events (Martin, 2000).*

## 5.5 Modification and Extension Approach for Prototyping MoteCare

The Modification and Extension approach for appropriating off-the-shelf devices for prototyping in scenarios, where connecting the system to a network is essential (Kranz, 2006), as is explained in the following section. The author describes the applicability of this Modification and Extension approach to the development of the MoteCare systems. Adding new hardware, such as sensors, to existing devices helps to extend their functionality and provide novel interfaces (Kranz, 2006).



As well the position of the mobile devices within the different stages of growth in the market (Ooi et al, 2005) illustrates the following points which the researcher had to consider:

- a) devices that fell into the Formalization and Expansion stages of the Stages of Growth theory were identified as the most suitable for prototyping, as some of these hardware interfaces are off-the-shelf devices or components;
- b) the traditional monitoring devices were left aside, as most of them represent fixed and/or proprietary devices with high power consumption. As stated earlier one of the objectives of this thesis was to attempt to demonstrate the use of commodity based hardware and software for health monitoring purposes rather than the use of proprietary devices. One of the underlying premises for the above was that open source hardware and software would lower the cost of health monitoring in line with the researcher's findings about the ever-expanding growth in healthcare costs;
- c) wireless laptops are in the most suitable stage of growth followed by handheld devices such as PDAs.

## 5.6 System and Interfacing Requirements

A Bottom-Up system requirement approach has been taken when analysing the type of interfaces to be used in the Mote-Care systems. In order to do this, the interface had to comply with the basic set of previously defined system requirements.

The table shown below shows the expected interface system requirements based on the previously completed MoteCare system analysis presented in chapter three of this thesis.

Table 5.3 MoteCare General System Requirements

General System Requirements	Interface Requirements should allow:
<ul style="list-style-type: none"> <li>▪ Persistent Health Care Monitoring System (24/7) of Patients/Aged People</li> </ul>	<ul style="list-style-type: none"> <li>▪ Visualization of the Data</li> <li>▪ Surveillance Data Correlation</li> <li>▪ Freedom for the patient (Mobility)</li> <li>▪ Access to the Data remotely</li> </ul>
<ul style="list-style-type: none"> <li>▪ Affordable and Scalable</li> </ul>	<ul style="list-style-type: none"> <li>▪ Allow for Open Source Tools / Standards</li> </ul>
<ul style="list-style-type: none"> <li>▪ Easy to use and maintain</li> </ul>	<ul style="list-style-type: none"> <li>▪ Commodity based equipment</li> <li>▪ Wireless sensor networks with accelerometers, barometers, light, humidity, temperature, microphones</li> <li>▪ Variety of interfaces such as a *BCIs, PDAs, Mobile phones, cameras</li> <li>▪ Network management software such as MRTG</li> </ul>
<ul style="list-style-type: none"> <li>▪ Smart -&gt; Reactive / Proactive</li> </ul>	<ul style="list-style-type: none"> <li>▪ Network Management correlation techniques</li> </ul>

*\* Despite the fact that BCIs are not at present an easy to use interface they were considered as an alternative interface for locked-in patient monitoring.*

Figure 5.2 shows a high level system diagram of the proposed system where the researcher required mobile interfaces between the sensors (as explained in Chapter 3) and the use of the network management tools (MRTG).

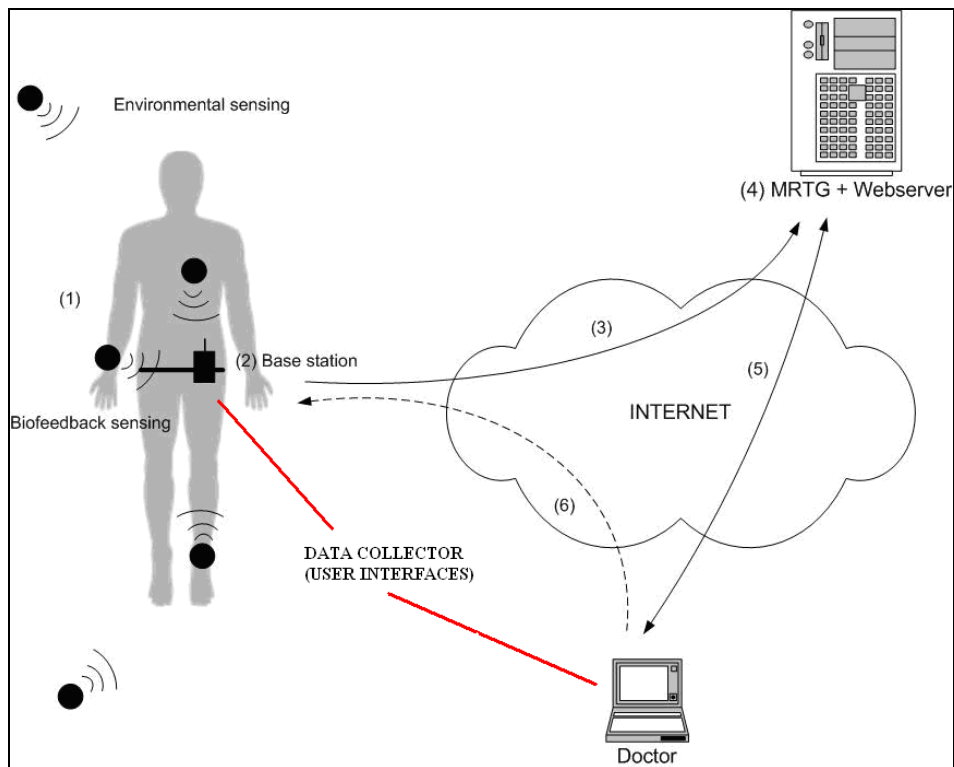

Figure 5.2 High Level MoteCare System Diagram (Lubrin et al, 2006)

### 5.6.1 Functionality of the User Interface: Data Collector Description

From Figure 5.2, data from each sensor {1} need to be propagated to the Internet. The data collector is the equipment in charge of retrieving all the data from the smart tags, interpreting them, and forwarding to a remote server via the Internet, in order to make them available to the designated user, either the doctor, the carer or the patient.

The main element of this subsystem is a base station mote {2}, which will establish a communication with all the other motes to receiving all the readings. Another element is an interface that will work as a

gateway between the motes and the Internet {3}. This user interface is the subject of analysis in this chapter.

Motes' smart tags have their own radio protocol. It means that they cannot establish any wireless communication with other devices except other motes. Consequently, all the data to be sent over the air using other communication protocols must be firstly redirected to another device such as a laptop or a PDA which supports other wireless protocols.

For a better understanding of the type of interfaces required to be used as part of the Data Collector, the expected system operation will be described. All the motes are sensing the vital signs and the environmental parameters, and continuously sending the data to a base station mote using their own protocol. This base station mote has a TinyOS application running all the time, which listens for the data from all the sensors, and forwards it through the RS-232 connector or serial port. As the motes do not have a DE-9 connector for serial communication the base station mote will be attached to the processor board (see Figure 5.3.), and use its serial port to connect it to the user interface to then send the sensed data to the MRTG Server {4} through the Internet.

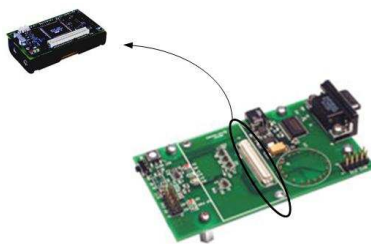

*Figure 5.3 MIB510CA Serial Interface Board and Mote Base Station  
(Crossbow Technology Inc., 2005)*

One high-performance processing platform called Stargate has been designed by Crossbow and Intel for sensing, signal processing, and

control to be used in wireless sensor network applications (see Figure 5.4). It can be used as a sensor network gateway and is used in the Stargate Motecare system the Medical MoteCare system (described in Chapters 6, 7 and 8).



*Figure 5.4 Stargate: X-Scale Single Board Computer and Wireless Networking Platform (Crossbow Technology Inc., 2005)*

The other component of the data collector is the user interface, running on either Linux or Windows operating systems (OS), and having the capability of accessing the information from the sensor board. This device would run an application developed for gathering the data and for graphically representing such information for the user or the patient. The information can be accessed in real time and historical data can be accessed through the Multi Router Traffic Grapher (MRTG) web server {4} as well (refer to Figure 5.2 showing the high level view of the system).

A summary of the main features of the operation of the interface application are:

- gathering the raw data from either the serial port or the Stargate server wirelessly via IEEE 802.11 transmission protocol;
- extracting the needed information from the data, like readings, group and mote ID, type of messages;
- presenting the data in a graphical format through a user friendly interface for the user;
- sending the data to the MRTG server using Wireless LAN, General packet radio Service (GPRS ) or Global Systems for Mobile Communications (GSM);
- accessing the MRTG server and displaying the created graphs in Hypertext Markup Language (HTML) via a web server.

### **5.6.2 Extracted User Interface Characteristics from System Requirements**

The results of the analysis of the system and MoteCare interfacing requirements are presented below:

#### ***i) Commodity Interface***

One of the main characteristics of the MoteCare system was its requirement to be developed using commodity devices or off-the-shelf components. The commodity concept is predicated on the assumption that the interfaces have incorporated components based on open standards that allow compatibility across platforms and promote lower costs (Commodity Computer, 2007).

***ii) Compatibility***

The interface should allow for compatibility in hardware and software with the MICA2 platforms. It should allow for the gathering of the raw data from either the RS-232 interface on the sensor board (or serial port), or from the Stargate server wirelessly via IEEE 802.11 transmission protocol.

- a) hardware and software compatibility to allow for a physical connection (serial interface) between the sensor board and the motes in order to act as a mediator device and to gather the information coming from the user;
- b) allow for a direct wireless connection to the Stargate Server or to the MoteCare Web Server through a Body Area Network (Babiloni, 2000), Personal Area Network (PAN), Local Area Network (LAN) or Wide Area Network (Connor, 2001) connection in order to access the already collected information.

***iii) Portable / Mobile***

The interface should adapt as much as possible to the user's mobility requirements, characteristics and the environment.

***iv) Processing Power***

The system should have enough processing power to at least be able to file or extract the needed information from the data collected, like readings, group and mote ID and type of messages.

**v) Allow for Multimodal Connectivity**

- a) for basic functionality of the system, the interface should allow for propagation of the information from one wireless communication protocol used in the Motes (wavelength spectrum of 400/900 MHz, or the 802.15.14 standard) to another, either wireless or wired, and then to transmit the collected data over IEEE 802.11 or Ethernet (IEEE 802.3) to the MoteCare web server. The ZigBee technology is used in the Medical Motecare system described in Chapter 9;
- b) from the accessibility point of view in a user mobile environment, the interface should allow connectivity through more than one LAN or WAN communication protocol so when the user changes location from one connection point to a different one, that user does not suffer from service interruption. For example, if using a laptop as an interface, the user can also send the data to the MRTG server using either a WiFi, Ethernet, GPRS or GSM connection.

**vi) Low Power Consumption**

Because of the inherent restrictions of the batteries used to power up the motes the system should conserve as much power as possible (see Chapter 3 for further details).

**vii) Storage Capabilities**

In the case of an inevitable connection interruption, in slow connection scenarios or in areas that require expensive connection re-establishment fees, the actual interface should be capable of some



filtering of the collected data and have enough storage capability to allow for buffering, or storage as the case may be.

**viii) Allow the Visualization of the Data**

The interface has to allow for the presentation of the data in a graphical or multimedia format through a user friendly interface. This can be presented through Web Interfacing via Graphical or Multimedia formatting of the data.

**ix) Secure**

From the security view point, as mentioned in Chapter 3, patient handled information is considered to be of a sensitive nature for reasons that can range from disclosure of sensitive personal and private information, to insidious attacks of masquerading using someone else's identity. Thus the interface should allow for secure connections via authentication, encryption methods, and reliable secure communication protocols.

## 5.7 Matching the Interface Requirements with Evaluation Results of Available Devices: Thin v Thick Client Interfaces

The overview of the different interfaces used in various medical applications, in addition to the system and interface requirements explained in the previous sections emphasize the need of an equilibrium between the combination of two totally different set of device characteristics. The first set points towards a wireless mobile low power consumption thin client interface whereas the other set of characteristics demand the need of such features in most cases provided by a thick client, such as high processing power, multimodal

connectivity, storage capabilities, and strong security features among others.

The selection from the existent suitable interfaces in the market for the development of the MoteCare systems was based on the following criteria in a hierarchical order of importance:

- a) the compliance with the basic technical requirements of the MoteCare prototype interfacing system to allow for the basic operation of the application;
- b) enhancements in functionality and usability, such as connectivity, portability, usability, scalability and open standards compliancy;
- c) spread of the various groups of mobile interfaces in the market – current trends as seen in the section of the Stages of Growth theory outlined in (Ooi et al, 2005).

## 5.8 Selected Devices for Prototyping:

For the MoteCare prototypes the researcher choose firstly laptops as will be shown in the MoteCare systems and secondly WLAN-enabled PDAs as described in the Mobile MoteCare system. The researcher felt that these devices were appropriate according to the Stages of Growth Theory as explained above and also according to the Modification and Extension Model of Prototyping that was set out earlier.

## 5.9 Conclusion

In this chapter the author examined the literature to ascertain the most suitable interfaces to use for the MoteCare systems. Laptops and PDAs were found to be in the Expansion and Formalisation stages and were readily available and commodity based items suitable for incorporation into the MoteCare systems. In the following chapter the

researcher will describe the building of the first MoteCare prototype and the use of Network Management techniques to manage the healthcare application developed. The advantages and disadvantages of the system will be discussed and results of testing of the systems will be used to inform the design of further systems Chapters 7 -9 will describe the building of the MoteCare systems using PDAs and Stargate as well as the medical application using pulse oximeters as well as the use of Network management tools to interpret and store the data and provide warnings.

# 6. The MoteCare System: The Core Functional Building of a NM based WSN HealthCare Application

*Building prototypes based on existing systems can, in many cases, make the overall development easier and quicker (Krantz and Schmidt, 2006).*

## 6.1. Introduction

As stated in Chapter One the research objective of this work is to show that accepted and proven Network Management models and techniques are suitable for the development of Wireless Sensor Network (WNS) Personal Healthcare applications such as monitoring a patient's temperature. The previous chapters have shown the theoretical underpinning of the research, namely:

- the social, economic and organizational reasons for developing wireless sensor remote health monitoring systems;
- the technology of WSNs;
- the potential of Network Management methods and tools for health monitoring;
- the selection of suitable interfaces for such health applications.

This chapter describes the development process, components and functionality of the first prototype of the proof of concept system named MoteCare. The first developed MoteCare system is based on a Two-Tier and an Agent Server Network Management (NM) Organizational Models (see Figures 6.1 and Figure 6.2). The Two-Tier model describes the relationships between a management entity and a set of managed objects. In a networking environment, the managed objects are a collection of networking devices that need to be monitored or managed, whereas the Manager Entity implies the monitoring system that collects the information from such managed objects, analyses it and stores it in a Management Database or MDB. Refer to Chapter 4 for a more detail description of each of these two NM models.

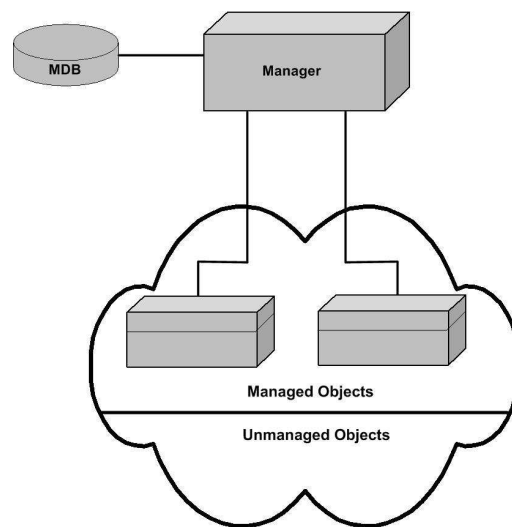

Figure 6.1 Two-Tier NM Organization Model (Subramanian, 2000)

## 6. CORE FUNCTIONAL BUILDING OF MOTECARE

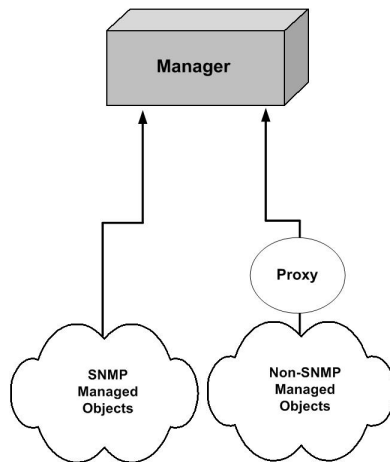

Figure 6.2 Agent Server NM Organizational Models (Subramanian, 2000)

In the first MoteCare system, the Two-Tier and the Agent Server NM Organizational models were combined and adapted to suit the needs of the system, see Figure 6.3.

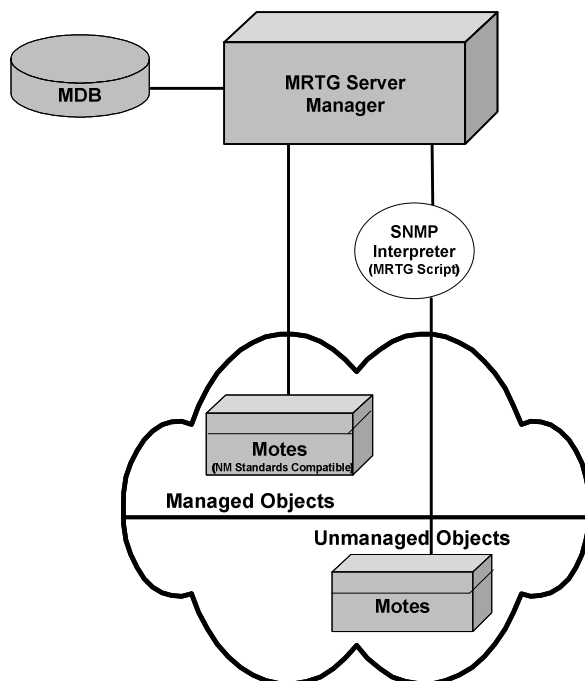

Figure 6.3 Adapted Two-Tier and Agent Server NM Organization Model to MoteCare System

The resulting adapted model is a Two-Tier NM Organization Model which uses the Agent Server NM Organization model structure to be able to manage the motes which are Non-SNMP enabled devices. This adaptation enables the motes and embedded sensors to provide environmental and medical data to the Manager and populate the distributed database or MDB. The Manager and the MDB in MoteCare is a networked system where the NM tool resides as the core component of the personal healthcare application.

## 6.2 Prototyping

Prototyping in the field of applied research and development is used to demonstrate an open source remote monitoring system. The prototype aids the investigation of the feasibility and viability of the core ideas, technical issues, and overall direction, as well as providing feedback for budgeting and other forms of commercial discussion and control (Wikipedia, 2006). Fischer (2008) quoted Wolfgang Schneider (1999) who stated that prototyping is a common methodology in system development. It introduces a cyclic procedure of developing, reviewing and modifying the prototype, as opposed to a linear development process. Prototyping can be a powerful tool in assisting the requirements and specification process yet they are rarely developed because they are considered too expensive (Hassan and Scott. 1981) Rapid Prototyping refers to systems that will eventually be discarded rather than becoming part of the finally delivered system. Using expensive components such as hardware for wireless sensor networks or medical equipment adds even more costs to the development process since different prototypes might need different types or versions of hardware (Fischer 2008).

A prototype is often used as a proof-of-concept which could be very useful for medical systems. New features or technologies are added to

the prototype to show the feasibility of the system. In addition prototypes can be used to get a feedback from potential users during the development process. Health care providers, specifically physicians, have certain common work environments and behaviours across different regions and specialties. Similar to other experienced professionals, they are sometimes uncomfortable when placed in a position where they are considered novices (Gosbee and Ritchie, 1997), (Fischer, 2008). During the process of prototyping doctors could have influence on the developed system while staying in a familiar environment. The prototyping stages of the MoteCare systems can be briefly described as the development of a proof of concept of an autonomous system for monitoring aged or chronically ill persons in their homes, in aged care facilities or as they move about in their outside environments. The architecture is based on frameworks developed from literature reviews of current and developing health monitoring systems, experiments with Motes and prototype developments and a novel approach of applying network management tools to health monitoring (Lubrin et al, 2006).

The series of prototypes for the MoteCare systems described in this thesis are not only based on the NM Organizational models previously described in Section 6.1, but also on the OSI Functional model previously described in Chapter 4. They represent proof of concept of the core functional entities in the building of the Network Management based solutions for mobile WSN applications in personal HealthCare monitoring systems. Some of these main functional entities are:

- remote monitoring;
- data collection;
- data visualization;
- storage and;
- smart correlation of the information;



as depicted in Chapter 4, Figure 4.4, which showed the intersection between an NMS and a WSN Personal Healthcare Monitoring System. The system is designed for remote access through Web interfacing to allow for patient and carer mobility and for the flexibility of a low budget, multiplatform environment. The researcher modelled the work on the OSI Functional Network Model, specifically concentrating on Performance and Fault Management as described in detail in Chapter 4. Fault Management is limited to Event Driven Alarming for the purpose of this thesis. This has been explained in Chapter 4, of this thesis). Fault management is deployed in the Medical Motecare system.

### **6.2.1 Open Source and Commodity-Based Technologies**

With most healthcare monitoring systems (both available or in development), the equipment used is generally proprietary and costly to the patient and/or state. CardioNet, for example, employs PDAs to collect data from the patient's own ECG monitor and sends it over a cellular network to a service center (Ross, 2004). Medtronic uses a dedicated monitor connected to the Internet to send pacemaker information to a medical professional (Ross, 2004) (Lubrin et al, 2006).

The author postulated that one possible way to reduce the cost of such systems is to use open-source and commodity-based technologies. Open-source products eliminate the requirement to pay royalties, while commodity-based equipment reduces dependence on one specific vendor for maintenance; thus, resulting in cost savings. In the MoteCare systems, Motes – small wireless devices used for transmitting sensor data – are one such commodity-based technology, along with firstly a laptop and secondly a PDA (for Mobile MoteCare). Applying an open-source network management approach (namely the

OSI Functional Model using the open source NM tool MRTG and later SNMP protocol and freeware such as CodeBlue) to the monitoring aspect also helps to reduce the cost. The researcher aimed to show that characteristic similarities between the network management and healthcare monitoring domains allow for adaptation of network management applications into this area (Lubrin et al, 2006).

Figure 6.4 illustrates the functional entities of the MoteCare system which will be discussed in the following sections.

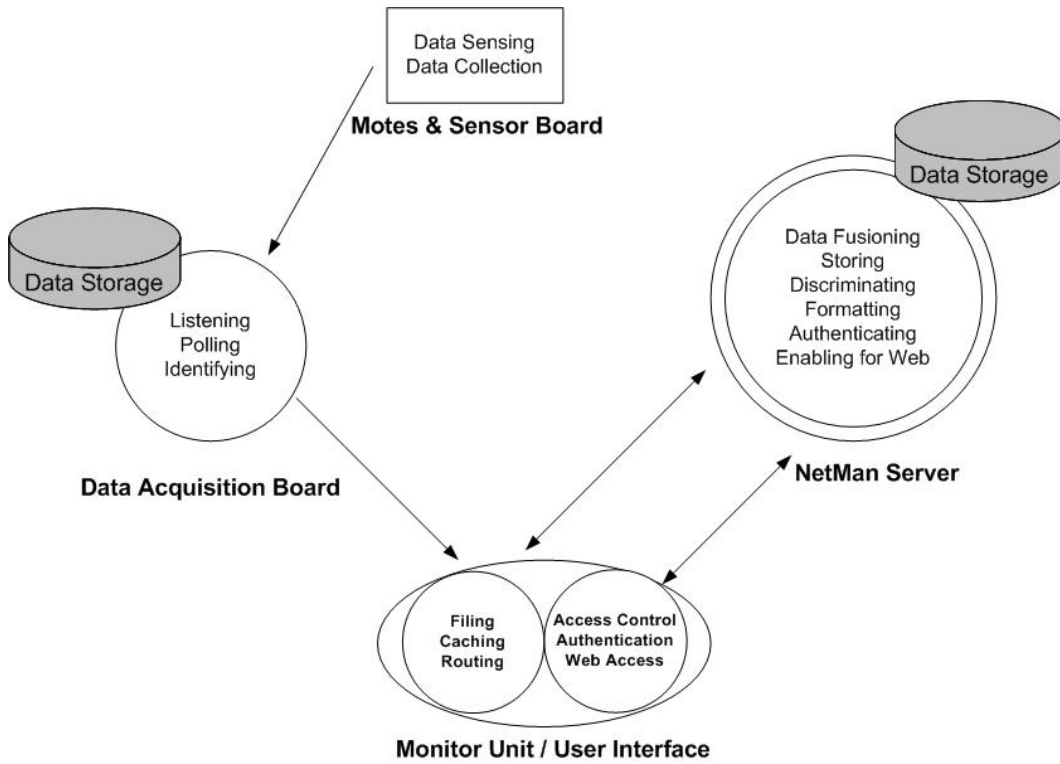

Figure 6.4 Functional Entities of the MoteCare System

## 6.3 Systems Development Methodology

As has been explained in the previous chapters, the author identified the requirements of the WSN healthcare monitoring system and identified the intersection between WSNs and NM systems. From this she developed the hypotheses:

**H.1** That a network management tool and models could be used to assist in the development of a Personal Healthcare Monitoring System and lead to the development of a generic network management framework for healthcare applications.

**H.2.** That such a personal healthcare monitoring system could replace medical monitoring proprietary based systems with less expensive commodity based hardware and open source software, and

**H.3.** That a network management tool could add intelligence to a health monitoring system by measuring and correlating a number of signals and alerting when certain conditions represent specific undesirable events or a threat for the patient.

In order to achieve a general framework based on accepted and proven Network Management models suitable for the development of WSN Personal Healthcare applications, the systems development methodology was applied to the building of the MoteCare systems as a proof of concept (Felix Navarro, 2006). The development of these systems was done incrementally on its functionality through the adaptation of the various NM Organizational models. The description and development of such prototypes are outlined in Felix Navarro et al (2006), Lubrin et al (2006), Lawrence et al (2004), Lubrin et al (2005) and (Riudavets et al, 2004).

## 6.4 Problem Domain

As explained in the earlier chapters the area of personal healthcare monitoring was identified as a potential candidate where this type of technology could alleviate the current shortage of nursing/caring personnel and provide cost reductions in the fast growing demand for healthcare services for elderly people (Felix Navarro et al, 2006). The identified system requirements are as follows (Felix Navarro et al, 2006):

*Table 6.1 Identified System Requirements*

The application should assist in the care of aged, ill or disabled persons
Commodity based equipment should be utilized as far as possible
The ability to correlate information from various sources including sensors collecting environmental data, such as accelerometers, barometers, light humidity, temperature and microphone sensors, is essential
The ability to interact with a wide range of interfaces such as PDAs, mobile phones, cameras, laptops and Brain Computer Interfaces is required.
Open source tools and commodity based hardware must be utilized as far as possible.
The system should be easy to use and maintain
The system should allow for remote monitoring
Future work will aim to make the system context aware

## 6.5 The High Level Architecture and Test Bed Setup for the MoteCare and Mobile MoteCare Systems

Various network management tools, models and techniques were analysed and selected to cover such primary requirements (as outlined in Chapter 4). The use of the Two-Tier Organizational and OSI Functional models in conjunction with the Network Management Performance tool Multi Router Traffic Grapher (MRTG) for its

implementation were selected and adapted to satisfy the requirements of the developed MoteCare and Mobile MoteCare systems.

The high level architecture of MoteCare and Mobile MoteCare monitoring systems is shown in Figure 6.5. The sensor network will communicate with the mobile monitor via a private LAN, while the monitor sends the data to the MRTG server through the Internet.

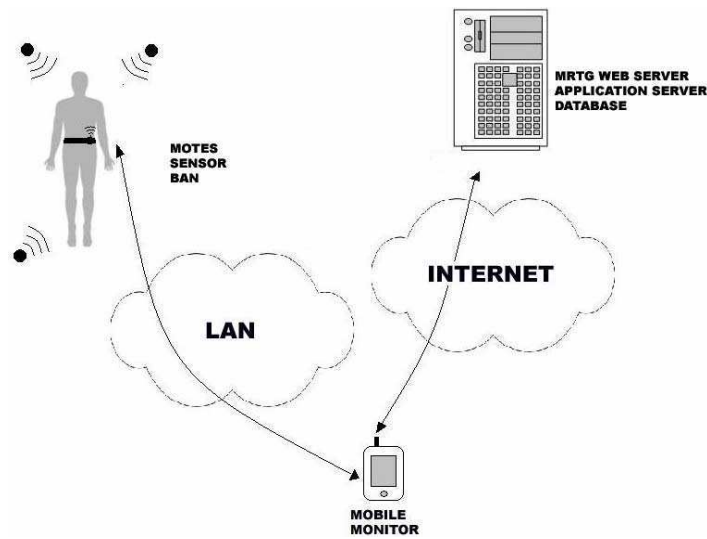
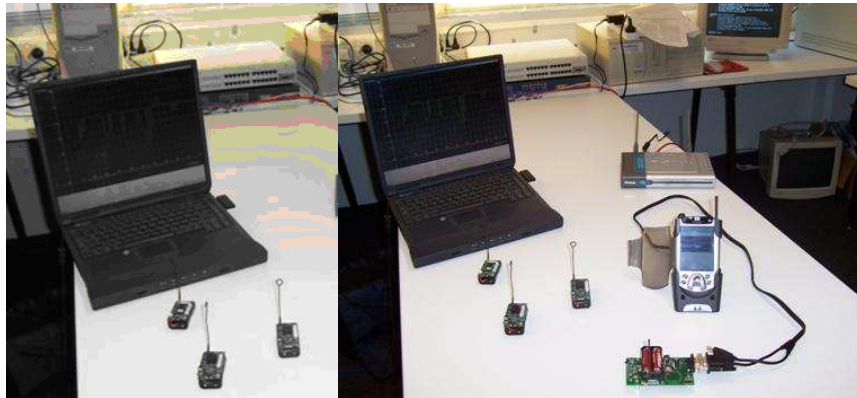

Figure 6.5 High Level Architecture of the MoteCare System

Figure 6.6 below illustrates the test bed set up for MoteCare on the left and Mobile MoteCare on the right. The following sections describe in further detail the architecture and test bed components of the MoteCare and Mobile MoteCare systems.



*Figure 6.6 The MoteCare and Mobile MoteCare Setup (Lubrin et al, 2006)*

In the MoteCare and Mobile MoteCare system architecture and setup in Figures 6.2 and 6.3, the two main entities of the Two-Tier model were implemented as follows. The three motes that form the Sensor BAN with their embedded sensors showing on the pictures are the Non-SNMP managed objects. These motes communicate wirelessly to the mobile monitor unit which is conformed by the mote sensor board connected to a mobile device, namely a laptop, PDA or Smartphone. The collected data is then sent via 802.11 from the mobile device to the computer system where the Manager and the MDB resides. The mobile monitor acts as a mobile gateway between the motes and the Manager, this feature was implemented in the Mobile MoteCare to allow for enhanced mobility of the monitored user or patient. A general layered communication overview of the MoteCare system is presented in the diagram shown in Figure 6.7.

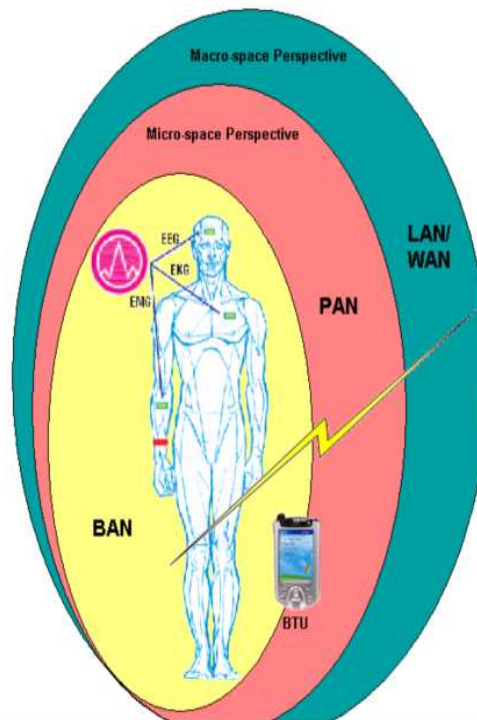

Figure 6.7 General Layered Communication Overview of the MoteCare System (Messina, 2004)

The motes or Non-SNMP managed objects reside in the Body Area Network (BAN) and the Personal Area Network (PAN) spaces or communication layers. The motes in the BAN provide information related to the monitoring of biomedical data coming from the user, whereas the motes located in the PAN will inject into the system the environmental information of the user surroundings. In the MoteCare and Mobile MoteCare systems described in this chapter a mobile device, namely a laptop or a PDA, are the border entities between either the BAN or the PAN spaces of the user and the Local Area Network (LAN) and Wide Area Network (WAN) layers.

The Manager entity and the MDB can be located in either the LAN or WAN layers irrespectively, that for the case of the diagram shown in Figure 6.4 these two layers are merged into one. The technical specifications of the Mote Kit used are contained in Chapter 3.

### **6.5.1 The Manager Entity and Management Database (MDB) – The MRTG Server**

One main goal for the first MoteCare system was to provide for remote monitoring of the patient. This was achieved by applying a network management approach to realize the remote aspect. An open source simple network management tool – Multi Router Traffic Grapher (MRTG) – was chosen to visually present the sensor data onto a webpage (Lubrin et al, 2005). To reiterate, Multi Router Traffic Grapher (MRTG) was selected for prototyping due to its flexibility to adapt to the monitoring of non-SNMP enabled devices and because it is an open source network management tool capable of collecting, storing, formatting, sharing and presenting the information graphically through a user friendly web based interface. Normally, MRTG is used to monitor network traffic using Simple Network Management Protocol (SNMP) for communication. MRTG gathers the traffic data and displays it on a webpage. It uses scripts based on Perl that identify the source of the data and establish formatting rules for graphical presentation. Data collected by MRTG is compressed and stored for, at most, two years before being discarded. MRTG provides a number of advantages. It is open source, so it can be readily adapted for other applications besides network management; it presents data visually and automatically using web based technologies; it provides short to medium term trends that can be useful with certain medical conditions; and it compresses data for efficient storage (Oetiker, 2006).

As previously explained, in the first MoteCare system, the motes base station was directly connected to the Manager entity or MRTG server on a laptop. In the later architecture of the Mobile MoteCare, with the addition of the PDA acting as gateway, the MRTG server could be placed in a remote location – a hospital, for example – while the motes or the WSN would be located elsewhere – at the patient's home.



Included in the architecture of the Mobile MoteCare was the ability for mobile monitoring; the patient or doctor present would be able to monitor the person's condition directly and instantly with a portable device (e.g. mobile phone or personal digital assistant). A more specific description of the implemented architecture of the Mobile MoteCare prototype is presented in the following sections.

Figure 6.8 illustrates the way in which MRTG graphically presents the captured data that can be remotely accessed via a web browser from any networked system capable of reaching the MRTG server and MDB. The images in Figure 6.8 correspond to the data collected from the initial MoteCare and Mobile MoteCare prototypes developed as proof of concept which used environmental sensors namely light, temperature and sound. Graphs of the data utilizing medical sensors it can be seen in Chapter 8 in which the development of the Medical MoteCare Prototype is explained in detail. As can be seen below captured data can be displayed from 5 minute up to 30 minute intervals, for example. Thus the first prototype illustrated that it was possible to display captured data in an easy to read format. It also illustrated that remote monitoring via the MRTG server was possible.

## Light Sensor Readings - Motes

The statistics were last updated Thursday, 30 September 2004 at 19:41

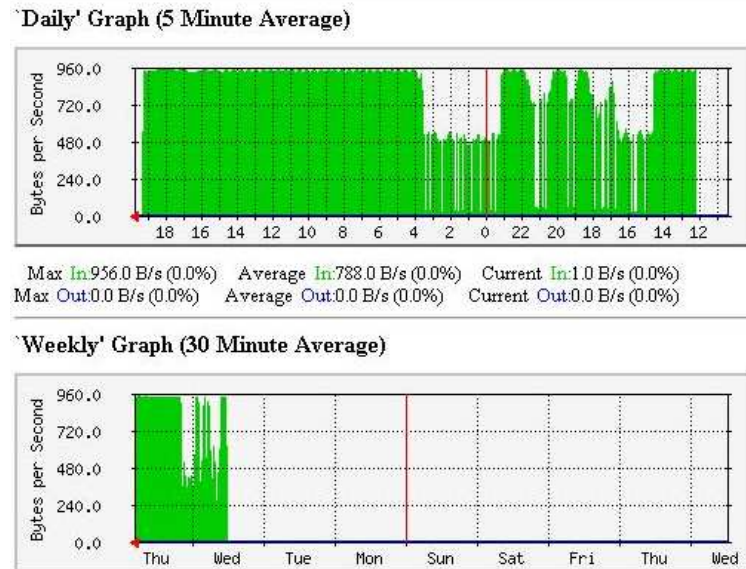

Figure 6.8 Graphical Representation of Captured Sensor Data Displayed on MRTG

### 6.5.2 Problems and Solutions for the MRTG Implementation in the MoteCare and Mobile MoteCare Systems

The first issue the researcher had to overcome with the implementation of MoteCare was the creation of the required proxy agent to allow the Non-SNMP object or motes to communicate with the Manager entity, in this case with the MRTG server. The proxy entity had to be located outside the motes as the constant polling of the SNMP agent from the Management entity (or entities) could potentially diminish the battery lifetime of such devices. As well the motes native proprietary operating system (TinyOs) did not allow at the time for the gathering of the monitored data through SNMP agents. The proxy agent developed was in the form of a modified perl script located on the MRTG server and an adapted function on the Motes side to communicate across entities. The author modified the listen

program/function on the motes side by adding a step that writes the data obtained from the motes on a file called "readings" on a continuous basis. This file is continuously accessed by the MRTG server which stores the gathered data in a distributed database. The MRTG server also enables the accessing of that distributed database through the Internet, and allows for the visualization of that information in the form of png formatted graphs through any system with a web browser. On the first MoteCare system the researcher utilized Cygwin shell to run the java program SerialForwarder or Listen (which are standard programs for the basic function of the Motes) from the laptop and also do the writings on this file. The SerialForwarder and listen programs open up the serial port on the programming board and listens for incoming data from the sensors. A sample config program is presented below in Figure 6.9. This represents a series of preliminary operations to configure the Motes to run the Serial Forwarder/ Listen from the PC in order to receive the data.

```

/opt/tinyos-1/apps/Blink
make install mica2 mib510,/dev/ttyS3

E.g. Surge
/opt/tinyos-1/apps/Surge
make install.0 mica2 mib510,/dev/ttyS3
make install.1 mica2 mib510,/dev/ttyS3
make install.2 mica2 mib510,/dev/ttyS3

Running the Serial Forwarder or Listen from the PC in order to
receive the data:
java net/tinyos.sf.SerialForwarder -comm serial@COM4:mica2
java net/tinyos.surge.MainClass 125

```

*Figure 6.9 Config File to run the SerialForwarder/Listen*

The MRTG tool running on that same machine utilizes a script with extension ".pl" which opens up the data file called Readings and uses the Perl language (the language MRTG is written in) to extract the

data. Figure 6.10 shows the way in which the author modified this file to ensure the extraction worked as she could not use SNMP for exchanging data.

```
# motereader.pl <pattern>
# Karla Felix Navarro & Jose Riudavets.
$file="C:\\wwwroot\\readingsformat.txt";
$pattern=shift(@ARGV);
#print "$pattern\n";
open(FILE, "$file");
while (<FILE>) {
    #print "test1\n";
    #if (/$pattern/io) {
        @a=split;
        if($a[0] == $pattern) {
            #@a=split;
            #print "test2\n";
# $d2 es el valor en azul
# $d1 es el valor en verde
            $d1=$d2=int($a[1]);
            print "$d1\n$d2\n0\n0\n";
            close FILE;
            exit;
        }
    }Close FILE;
```

*Figure 6.10 Reader File*

### 6.5.3 Three Motes as Clients

The three motes as depicted in Figure 6.6 communicate with a sensor board through the serial port on the laptop. Data from this Mote network passes through a gateway (in the MoteCare system the processing board with a listening Mote connected to it) and then to the MRTG server. The Motes do not have the capacity to capture and store huge amounts of data hence the use of MRTG. There is a database that

is available with the Motes called TinyDB but the researcher did not use it because of the open source requirements of this system and because she wanted to store large amounts of data over a long period of time.

Initially, when setting up the test bed, the author had the following problems. The original kit used a wired serial port for connectivity which went against the author's systems requirement for a fully wireless setup. The RF set up did not allow for flexibility to use other wireless technologies such as Bluetooth, WiFi and GSM. The kit limited the options for the researcher in setting up the system. In developing the system the researcher noted the lack of robust signalling from the motes if they were moved. The antennae were easily broken off; the battery packs made the motes bulky and had to be changed often during the life of the MoteCare system.

### **6.5.4 The Enhanced Mobile MoteCare**

As discussed in Chapter 5 on Interfaces for Health Monitoring Systems, a PDA was identified as being a suitable interface for enhancing mobility for the system. The Mobile MoteCare system uses a PDA as part of the mobile monitor. The MRTG tool enables the gathering of the data from a mobile patient through the PDA and seamlessly allows the remote viewing of graphical data from the server.

On the Mobile MoteCare system, in addition to the system's remote capabilities it allows the patient or the user to be monitored in an enhanced mobile and real-time environment through the PDA. As well, users are able to conveniently tailor the sensors and/or network according to their requirements. The user would, for example, have the ability to change the sampling rate of data or focus on specific sensors.

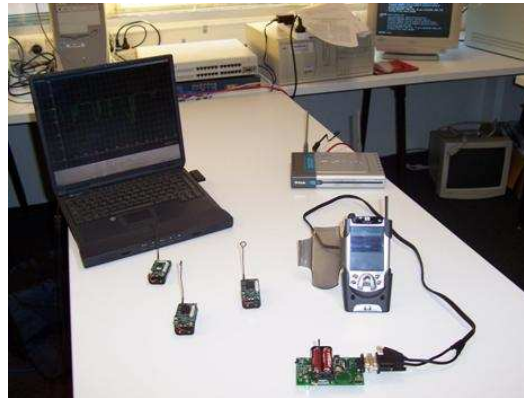

Figure 6.11 Mobile MoteCare Featuring a PDA Mobile Monitor

The mobile monitor consists of a PDA attached to a base station mote as seen in Figure 6.11. The PDA is an HP iPAQ H5450 with Pocket PC 2002 and the following technical specifications:

- Intel XScale 400MHz Processor;
- 48MB Flash ROM/64MB SDRAM;
- integrated Wireless LAN 802.11b;
- integrated Bluetooth;
- serial cable connection.

With this family of MICA2 motes, the base station mote must be connected to the PDA using a serial connection (RS 232). The PDA acts as gateway between the WSN for the MoteCare Body Area Network (BAN) monitoring and the MRTG application server by utilizing RF (ISM 916 MHz) and Wi-Fi (802.11b) communication respectively as shown in Figure 6.12. The utilized wireless access point can be seen in Figure 6.8 just above the PDA.



*Figure 6.12 The Mobile MoteCare Setup  
(Lubrin, Lawrence and Navarro, 2006)*

The Mobile Monitor performs mostly the same functions as MRTG with the addition of data processing. It presents data visually to the patient/doctor albeit in real time compared with MRTG (every five minutes). With the Motes' base station now directly connected to the Mobile Monitor – in this case, a PDA was used – sensor information is extracted and processed from packets coming through the WSN within the device itself. Now the user is able to carry the device throughout the household. Similarly, the data processed by the monitor is simultaneously sent, via wireless (Wi-Fi), through the Internet to MRTG.

### **6.5.5 Mobile MoteCare Implementation Problems**

In setting up the test bed (See Figure 6.9) the author encountered several problems. The Base Transceiver Station (BTS) is composed of the programming board with serial port (MIB510) and a MICA2 controller connected on it with radio communication and power supply (two AA batteries) features. The other MICA2 controllers are directly connected to the sensor boards (MTS310) and use radio frequency (ISM 916 MHz) to communicate. The Bridge Transceiver Unit (BTU) is

the point of connection between the sensor network and the MRTG server (see Figure 6.13).

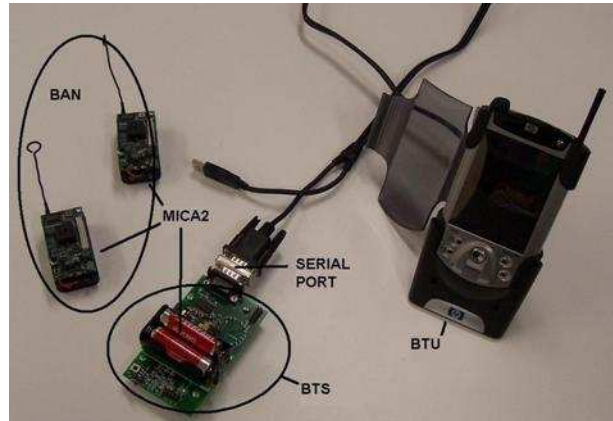

Figure 6.13 BTS/BTU Connection (Messina, 2004)

Several problems were encountered in establishing communications between the base station mote and the PDA. The first proposal was to use Bluetooth via a serial to Bluetooth adaptor, in order to send wirelessly the raw data from the programming board to the PDA. However, this adaptor needs to be supplied by the device to which it is attached and, in this case, the programming board did not enough power to achieve it. Finally, a serial connection (DB9), based on the RS232 protocol was used. The PDA did not have a DB9 connector, but there was expansion pack available (see figures 6.11 and 6.14) to allow the use of a PCMCIA - to- serial adaptor. Further commodity based hardware issues emerged when the wires on the adaptor were found to be incorrectly twisted and they had to be re-arranged.



## 6. CORE FUNCTIONAL BUILDING OF MOTECARE



Figure 6.14 Ipaq Expansion Pack (Compaq)



Figure 6.15 PCMCIA to RS232 Adapter (Triangle Cables)

Next generation programming boards (attached to the base station mote) have WLAN capabilities (i.e. – MicaZ motes) (Crossbow Technology Inc., 2005), allowing for complete mobile monitoring setup. The mobile monitor serves two major purposes within the system:

- provides real-time remote monitoring to the medical professional;
- bridges between the wireless sensor network and the web server.

For the Mobile MoteCare a graphical front-end was created to display the readings from the sensors in real-time (Lubrin et al, 2006). Theoretically, it can monitor a maximum of 65,535 motes at one time, albeit with performance tradeoffs. The application is written in C# using the .NET Compact Framework. Initially, Java was chosen as the language and platform for the application. However, for simplicity, C# was selected as the compact framework can easily be installed to any

Pocket PC or Windows Mobile device. The compact framework is also a subset of the full .NET framework, making the transition from a desktop to portable platform smoother (Microsoft Developer Network, 2005). Using Sun's J2ME platform requires choosing between different configurations and profiles depending on the PDA used. In addition, depending on the configuration (Connected Device Configuration {CDC}) or (Connected Limited Device Configuration {CLDC}) compatibility with the desktop platform Application Programming Interface (API) may not be easily achieved (Java Technology, 2005). Figure 6.16 shows a sample of the C# code used.

```

// write the readings for the notes if all stated
// notes have data
oscope.dataAvailable(numNotes, DumpUpdate.valueNotes,
    DumpUpdate.idNotes);

// format out the data into a file
DumpUpdate.formatPrint(formatFile, 0, 0, true);

// reset flags
DumpUpdate.printOut = false;
DumpUpdate.count = 0;
DumpUpdate.valueNotes = new ArrayList();
DumpUpdate.idNotes = new ArrayList();

// send to web server
if(client.isConnected())
{
    client.TCPsendFile(formatFile);
}

```

Figure 6.16 Sample C# code from PDA

The architecture of the base station limits its potential for a true mobile monitoring system. Here, the PDA bridges the base station to the Internet: The monitoring application uses sockets to make a connection to the receiving server on the network. Microsoft's .NET Compact Framework provides two ways of accessing services from a network computer/server: Sockets and XML Web Services. Sockets provide access to lower level protocols such as TCP; XML Web Services provides access using HTTP (Microsoft Developer Network, 2005). Considering that the mobile monitor will communicate with the server within a private network, the choice of using sockets is suitable. If the

web service had been used, large amounts of XML data would have had to be transferred (Microsoft Developer Network, 2005). The socket solution meant that data is transmitted as a text file and is directed to the MRTG server for processing, representing a huge reduction in network traffic (Lubrin et al, 2006).

## 6.6 Evaluation and Testing of the MoteCare and Mobile MoteCare Systems

Individual testing of the MoteCare system continued for several months with a number of subjects (12) starting in 2005. Written instructions were issued to the testers as verbal instructions did not seem to work, particularly with the use of the PDA on the Mobile MoteCare system. A copy of the written instructions is found in Appendix B of this document.

The testing of The MoteCare prototype involved the use of 3 motes with light sensors placed in different locations within a room. One Mote was under a desk, the second one was near the laptop server and the third one was on a bookshelf. Once the WSN MoteCare system motes were communicating with the MRTG server, the subjects from the Advanced Research in Networking and Mobility laboratory in the Faculty of Information Technology at the University of Technology Sydney were asked to come individually to the room to observe the system for periods of up to an hour. A research assistant was present for troubleshooting purposes and to adjust the lighting in the room - from total blackness with all lights off and blinds down to complete lightness with all lights on and blinds up. The **System** evaluation involved the observation of the changing graphs as presented on the MRTG server on the laptop. In the **Test** evaluation, the user was not required to operate any controls on the motes or the MRTG interface

but merely had to observe the changes that appeared when the parameters changed.

The majority of the subjects found the system generally easy to understand, however some of the comments for qualitative research purposes are presented below:

- "It works fine, but it is hard to observe the accuracy of the data". This subject had no trouble following the instructions, but obviously felt the MRTG graphs displayed were not sufficiently finely grained for the subject to be able to distinguish minor changes in the measured data. Obviously the inability of distinguishing fine changes in the reading can potentially be a problem with medical applications.
- "It requires a lot of concentration to keep to 10 minute intervals and change the light parameters". MRTG refreshed the graphs every five minutes. This subject's comment illustrates the fact that the MRTG graphs refresh rate was slow and require too much concentration on the subject's behalf to observe a change. The researcher recognised this as a problem and ascertain that she could download a patch which could then enable MRTG to refresh the graphs every minute. As these are initial testings of the system the researcher considered adopting these features on later implementations.
- "I had to refresh the MRGT graphs". In the testing with this subject the MRTG graphs froze and the subject had to do it manually. This was found to be networking problem in the lab which the researcher had to investigate further.
- "You need finer timing intervals". This subject also found the length of time for refreshing the graphs too long.

### 6.6.1 Mobile Motecare Tesing

For the testing of The Mobile MoteCare the subjects were again asked to observe the captured data and graphs on the PDA. The set up for testing the Mobile MoteCare was similar to the testing of the initial MoteCare prototype except that the users had to operate the PDA in order to see the graphs and to control the starting of the tests.

The majority of them considered the Mobile MoteCare system was "Generally Easy" to use however there were problems as illustrated below.

- "MRTG showed no graphing changes for the first 22 minutes". This subject found that the data did not refresh for the 22 minutes of observation. The research assistant undertook debugging and found the wrong file was being accessed from the script and changed files. Once the MRTG script was pointing to the appropriate file the system performed well with no further issues.
- "PDA is frozen and the application is frozen too at 12.22. No data is sent or received. After 8 minutes the application crashed at 12.30. The PDA kept turning off every few minutes". As mentioned earlier the PDA needed a hardware upgrade, the researcher continued testing but realized that the hardware was not adequate for the task of testing. This is further illustrated by such comments as the PDA "kept turning on and off every few minutes" and "We had technical issues"
- "Graphical output was not labelled so what was measured was hard to discern". On the graphical user interface one subject had issues with the instruction "Click OK" as the "OK" was sometimes obscured by the soft keyboard on the PDA. This problem was fixed up in the next iteration which is called Stargate MoteCare discussed in the following chapter.

It became apparent that the PDA was not stable enough for continuous testing, so the researcher requested for a PDA hardware upgrade which was received in time for the building of The Stargate MoteCare system. Tests on the performance and usability of the system showed that several improvements were necessary. One issue that required improvement pertains to the real time perception of the system, mainly in the updating of the graphs. Over time, the user would experience a slowdown, where the delay between a change in the conditions and that change appearing on the graph, increases. Real time processing of the data within the PDA itself requires a significant amount of resources and so may be a major factor in performance.

Further examination of the code lead the researcher to conclude that the system slowdowns were in addition caused by the data buffer overflow, namely the buffer was not able to accept the data quickly enough.

Some of these previously explained issues lead to the development of the Stargate MoteCare system and further investigation of the use of different NM tool and an SNMP proxy on the management entity side of the system.

## 6.7 Results and Discussion

As the **System** evaluation and **Test** only involved observation, the results reflected that 90% found the system and the test "Generally Easy". The changes in the light intensity in the room took longer to be reflected on the graph than expected as MRTG had to poll the reading file every five minutes. As well, once the data file was modified another five minutes could be added before the graph reflected the change if MRTG polled the file just before it had been modified. The author realized that such time lags would make the system inadequate

for critical health condition such as a heart attack but would be satisfactory for non-life threatening conditions such monitoring a person's body temperature. NM Fault management techniques were used in later systems (Chapter 8) to try to improve system performance in threatening health situations.

## 6.8 Conclusion

This chapter described the building of the MoteCare and Mobile MoteCare prototypes and illustrated the way in which a network management tool, namely MRTG, was used to store the captured data and display it in a graphical format This chapter also outlined some of the shortcomings of the system, namely the lack of robust signalling from the motes, short battery life, difficulties in connecting the system up wirelessly in the first prototype, the lack of medical sensors and the necessity to use light, temperature and sound sensors for proof of concept development. The testing of the MoteCare and Mobile MoteCare systems enabled the researcher to see what improvements needed to made, specifically the need to make the system communication more robust and reliable from the BAN and PAN to the LAN/WAN layers led to the development of the Stargate MoteCare system which will be described in the next chapter.

The Mobile MoteCare used a PDA to allow for user mobility. User raw data can be captured in real time on the PDA. The PDA sends the data to the server to be stored and formatted for presentation on graphs that can be viewed either on the PDA or other web enabled devices. The main objective of the Mobile MoteCare prototype was to create an enhanced mobile working system between the wireless sensor network and the server. This was achieved but hardware and software issues as discussed in this chapter proved challenging. In the testing of the Mobile MoteCare system issues of connectivity and portability were

identified. Analysis of the underlying code showed that the data buffer was the likely cause. In terms of usability, the researcher believes that since the device is primarily intended for either medical personnel or patients, or both, the application should be simple to use. In fact Mallat(2007)who has done a study on a majority of the acceptance models available, has shown that 'Ease of Use' is one of the most important determinants of new technology acceptance. This aspect of the MoteCare and Mobile MoteCare systems is addressed in the development of The Stargate MoteCare system.

In Chapter 7, the development of The Stargate MoteCare system is described. This system uses an Stargate Processor Board (Wi-Fi enabled) which provides the advantage of a middle manager or agent and provides physical separation and wireless connectivity between the base station mote and the mobile monitor and addresses some of the shortcomings of the Mobile MoteCare prototype.



# 7. The Stargate MoteCare: The Adaptation of a Three- Tier NM Distributed Model

*Perhaps, someday, electronic sensing will be as natural to us as our own innate senses. Only time will tell (Elson and Estrin, 2006).*

## 7.1 Introduction

The construction and testing of MoteCare and Mobile MoteCare systems based on the two-tier NM organizational model indicated that further improvements to the system were necessary if the researcher was to meet the system requirements presented in Table 6.1 and to prove the Hypotheses presented in Chapter 1.

The building and testing of both MoteCare and Mobile MoteCare were based on the two-tier NM organizational model. The advantages of a distributed NM Three-Tier Organizational model were incorporated into the Stargate MoteCare. Middle management, portability, buffering and full wireless connectivity issues were addressed by the acquisition of the personal server called Stargate for the WSN side of Stargate MoteCare. In system tests on the MoteCare and Mobile MoteCare systems, subjects had indicated a need for improved usability features and such features were also addressed and implemented in this prototype.

In the adapted NM Three-Tier Organizational model presented in Figure 7.1, the Stargate device acts as a smart middle management server capable of polling, storing and processing part of the collected data to then send it to the MRTG server and handheld devices by request (Felix Navarro et al, 2006). The Stargate personal server also bridges each of the radio frequency communication BANs and BAN network layers directly with the LAN and WAN IEEE 802.11 Ip/Ethernet communication layers without the need to pass through the Mobile Monitor Unit to transfer the sensed data to the MRTG server. The Stargate acts as the intermediary between two different modes of data transmission and brings independence to the PAN layer without compromising the mobility of the user in the BAN layer as shown in Figure 7.1.

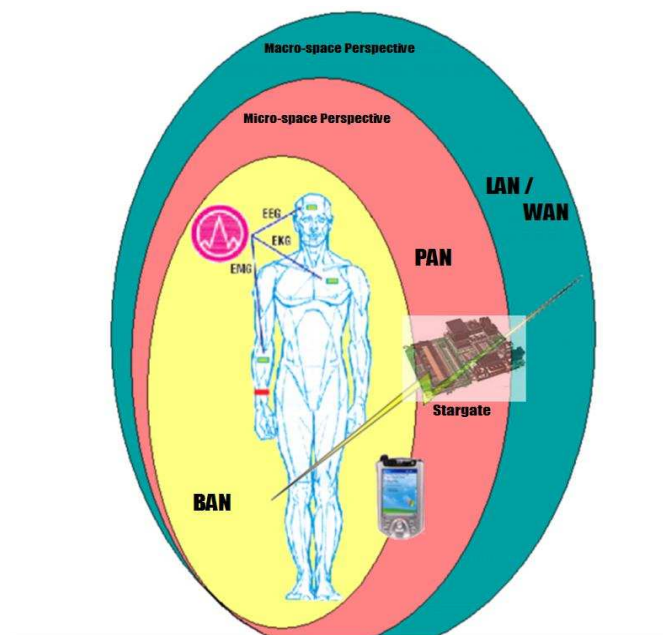

*Figure 7.1 General Layered Communication Overview of the Stargate MoteCare System*

In the case of MoteCare and Mobile MoteCare the mote sensors used Radio Frequency to send the data to the handheld device and the MRTG Server in the LAN via IEEE 802.11. Figure 7.2 shows the

position of the Stargate in the three layer model which was used for the implementation of the Stargate MoteCare system.

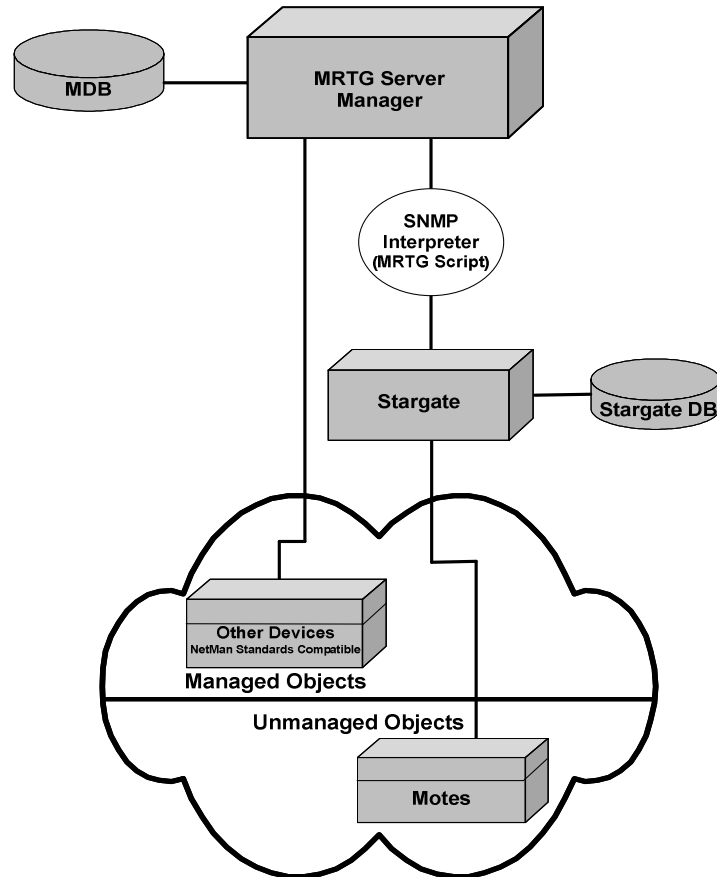

*Figure 7.2 The Adopted Three-Tier and Agent Server NM Organization Model to the Stargate MoteCare System*

The adaptation of the Three-Tier NM Organization model not only reduces the storage and processing resources required in the wireless sensor nodes as in the Stargate MoteCare system, but also makes the Medical MoteCare system capable of having more than one manager entity without the risk of redundant or excessive polling the motes.

An important variation in the adapted Three-Tier NM Organization model presented in Figure 7.2 is the database structure of the middle management or agent entity. This database is native to the WSN

Stargate middle management entity, and not of an SNMP management information base (MIB). Refer to chapter 4 for MIB details.

## 7.2 The Stargate MoteCare Description

Building on MoteCare and Mobile MoteCare, the Stargate MoteCare implementation aimed to improve the user experience by augmenting the system with increased functionality. It also aimed to resolve a number of issues such as fixing the slowdown in graphical refresh rate and providing a better graphical interface for an improved user experience. Figure 7.3 below shows an updated high-level view of the system and the changes will be discussed in the following sections.

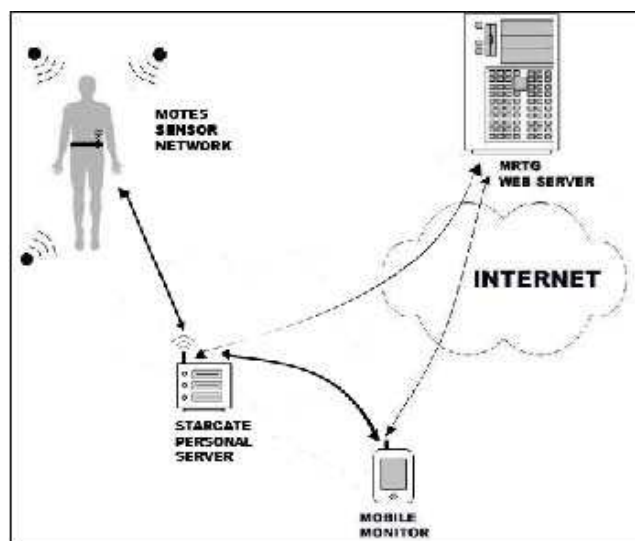

Figure 7.3 System Overview of the Stargate MoteCare

### 7.2.1 Motes Sensor Network

In accordance with the architectures of the previous systems, the Mica2 family of Motes was used in The Stargate MoteCare system which used light, temperature and accelerometer sensors in addition to some sound features for mote identification purposes. The motes were programmed with the modified Surge program from (Crossbow Technology Inc., 2005) to monitor changes in brightness, and temperature (environmental and external body), and horizontal and vertical movement.

### 7.2.2 Stargate Server

The architecture of the system was improved with a local server called a Stargate server to remove the processing burden from the Mobile Monitor (refer to the updated high level system overview on Figure 7.3). The Stargate server (see Figure 7.4) was developed by Intel researchers for 'ubiquitous access to personal information' (Stargate, 2005). Key features of the Stargate server are:

- 400 MHz PXA55 XScale Processor;
- 64 MB SDRAM, 32 MB Flash;
- Ethernet connection;
- compact Flash slot;
- Wi-Fi ready;
- Linux kernel.



*Figure 7.4 Stargate: X-Scale Single Board Computer and Wireless Networking Platform (Crossbow Technology Inc., 2005)*

The Personal Server, Stargate has the ability to connect wirelessly to other devices using Wi-Fi, GSM and GPRS. This hardware allows a system to move from a centralized network management system to a distributed one. Stargate acts as a smart middle management server capable of polling, storing and processing part of the collected data to then send it to the MRTG server and handheld devices by request. Stargate is also an intermediary between two different modes of data transmission. In the case of the Stargate MoteCare system it communicates with the mote sensors via Radio Frequency (916 MHz) and sends the data to the handheld device and the MRTG Server in the LAN via IEEE 802.11.

In the Mobile MoteCare system, the Mobile Monitor (PDA plus the processor board) performed all the tasks of receiving the sensor network packets, parsing them to obtain the required sensor data, presenting the data on graphs and repackaging them for wireless transmission to the MRTG server. Test runs on the Mobile MoteCare system showed that, over time, the user would experience a significant slowdown in the refresh rate of the graphs. As indicated in Chapter 6's conclusion, analysis of the underlying code showed that the data buffer was the likely cause of such a slowdown. However, reducing the buffer

limit meant that much of the more recent data would be lost and could pose a risk to the user. This could be potentially life threatening in the case of health monitoring so it was necessary to solve this issue.

The Stargate could be located locally in the user's home, and act as the gateway to the WSN. Portable devices such as the PDA can connect wirelessly to the Stargate and use its storage and processing capabilities. As the gateway to the WSN, the Stargate is programmed to accept commands from mote clients, such as requests for:

- transmitting data;
- gathering sensor information;
- changing the sampling rate;
- turning on/off a Mote;
- turning on/off different sensors on the motes.

The Mobile Monitor in the Stargate MoteCare system consists of an updated PDA that is wirelessly connected to the Stargate server. The PDA is an HP iPAQ rx3417 with Windows Mobile 2003 Second Edition and the following technical specifications:

- Samsung S3C 2440 processor;
- 92 MB Memory;
- integrated Wireless LAN 802.11b;
- integrated Bluetooth;
- serial cable connection.

The main features of the operation of the PDA application in The Stargate MoteCare system are:

- gathering the raw data from either the serial port or the Stargate server wirelessly via IEEE 802.11 transmission protocol;

- extracting the needed information from the data file, such as readings, group and mote ID, and type of messages;
- presenting the data in a graphical format through a user friendly interface;
- sending the data to the MRTG server using Wireless LAN. GPRS or GSM communication technologies are also available but were not tested in the performed experiments presented in Section 7.3;
- accessing the MRTG server and displaying the created graphs in HTML via a web server.

The Stargate MoteCare system provides a full mobile experience as the WSN gateway is separate from the PDA. The monitor serves a number of major purposes within the Stargate MoteCare system and provides proof of concept for potential healthcare applications by providing:

- real-time remote monitoring to the health professional and/or carer;
- WSN configuration capabilities in situ;
- an intuitive warning system (as per the fault management requirement specified in the original system design described in Chapter 6, Section 6.2).

Figure 7.5 illustrates sample C# code on the PDA that enables the real time monitoring of light readings (in this case) to be forwarded then to the MRTG server.



```

// write the readings for the notes if all stated
// notes have data
oscope.dataAvailable(numNotes, DumpUpdate.valueNotes,
    DumpUpdate.idNotes);

// format out the data into a file
DumpUpdate.formatPrint|formatFile, 0, 0, true);

// reset flags
DumpUpdate.printOut = false;
DumpUpdate.count = 0;
DumpUpdate.valueNotes = new ArrayList();
DumpUpdate.idNotes = new ArrayList();

// send to web server
if(client.isConnected())
{
    client.TCPsendFile|formatFile);
}

```

Figure 7.5 C# Sample Code (Lubrin et al, 2005)

In Figure 7.6 the Stargate MoteCare graphical user interface is depicted. Users and healthcare providers log in to the system and are presented with views that match different profiles. The use of a login name and password is mandatory for security purposes, especially as this system is a proof of concept for a healthcare system. For example users may monitor temperature and light in different rooms by changing the view from Bedroom 1 to Living room. This GUI is also suitable for viewing on the PDA.

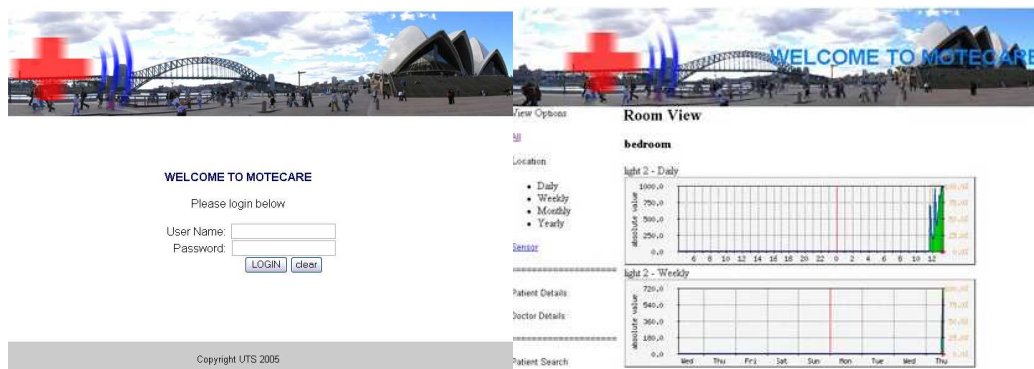

Figure 7.6 Graphical User Interface of The Stargate MoteCare System (Lubrin et al, 2005)

Additional elements were added to the graphical user interface (GUI) of the Mobile MoteCare to accommodate the new capabilities of the system. For example, the user can now open a new window in the application to configure at least one Mote in the sensor network. A mote can be configured by first locating it with the 'Beep' button, then by clicking on a specific parameter to change, such a sampling rate (see Figure 7.8). As well, the Mobile Monitor in The Stargate MoteCare is capable of:

- showing error/debug messages during runtime;
- changing connection settings;
- displaying help pages;
- monitoring multiple rooms – the bedroom, living room, etc;
- switching views whenever shifting locations.

Figure 7.7 shows a view of the graphs on the PDA.



*Figure 7.7 Stargate MoteCare Showing Graphs (note the cable from the Stargate is plugged into the PDA charger in this photo)*



*Figure 7.8 The Stargate MoteCare Showing Interface View of Network Control*

Figure 7.8 shows the interface which allows for network control of the Stargate MoteCare system, for example, authorised users can change the mote parameters such as mote numbers.

In the Stargate MoteCare system, users can switch between a graphical representation of the data or a textual one. Users may prefer to look at numbers rather than graphs (see Figure 7.9). The choice of whether to view debug/error messages is up to the user (the default is 'off'). This is an example where the user can decide on the level of involvement/comfort with the system.



Figure 7.9 Textual and Graphical Representation of Sensor Data  
(Lubrin et al, 2006)

The monitoring application uses sockets to make a connection to the Stargate server on the network. Microsoft's .NET Compact Framework provides two ways of accessing services from a network computer/server, sockets and XML Web Services, as outlined in Chapter 6.

### 7.2.3 The Manager Entity – The MRTG Server on the Stargate MoteCare System

In The Stargate MoteCare the system was designed to be used by several users at one time. As MRTG captures measurements, all files are updated simultaneously. In this case a database was deployed to structure and store the captured data related to each user (Lubrin et al, 2006).

MRTG is able to handle the sensed data from the motes and the system takes advantage of its particular characteristics as set out below:

- storing structured data in the MDB in the form of a PostgreSQL database for long-term storage The MDB can be physically located within the server or on a separate networked system;

- fusing the collected data from different motes;
- monitoring for threshold levels – on the system, thresholds were set for different parameters such as light intensity and temperatures and a sound alarm was triggered if thresholds were reached.

The latest release PostgreSQL (Group, 2002), a free and open source database, which runs as a server natively on Windows, was chosen for long-term data storage.

### **7.2.4 Smart Monitoring System**

A smart remote healthcare monitoring system automatically changes sensor parameters and notification settings according to the user's condition, profile and further patient/health carer input. The Stargate MoteCare saw the implementation of some of these smart adaptive features such as:

- authentication and authorization of users, via logon and password control;
- profiling of patients and healthcare workers – different views of the system are available to different users;
- automatic modification of sensor parameters via profiles;
- efficient transport of user data over wireless communication;
- secure storage of patient records on PostgreSQL (Lubrin et al, 2006).

### 7.3 Evaluation and Testing of the Stargate MoteCare

Individual testing of the system continued for several months with a number (8) of researchers starting in 2005. It was also demonstrated to groups of researchers at seminars at the University of Technology.

A description of the goals and description of the system testing of the Stargate MoteCare system is shown below in Table 7.1.

*Table 7.1 Testing Instructions for the Stargate MoteCare System*

<b>The overall system goals of Stargate MoteCare</b>	<b>Remote and mobile monitoring of aged and disabled persons using WSN and NM tools.</b>
Overall System Description	Use of Motes or other commodity-based technology as underlying sensor network. Sensor network would monitor the patient's vital statistics and surrounding environment continuously. Information from this network will be forwarded to a remote, local or mobile client. The information can also be presented in real-time or periodically. The underlying sensor network can also be modified to fit the patient's need. The system would intelligently monitor the patient and send a warning of any deterioration of the patient's condition to a medical centre.
Goals:	Employ a PDA for real time mobile monitoring of the patient Maintain MRTG on the server side to monitor the patients Partial implementation of overall system
Stargate MoteCare Components	MRTG web server Motes sensor network Light sensor, temperature sensor, sound sensor Desktop/notebook computer PDA
Stargate MoteCare System Description	Sensor network is directly connected via the base station to the PDA. The network only streams sensor information to the PDA, which presents and forwards the data to the MRTG web server, located on the desktop. MRTG gathers the information and presents them on a graph, which is

	updated every five minutes. The PDA presents the information as soon as it receives the data.
Limitations	Proof of concept. Light and temperature parameters have been implemented. Sound beeps made when threshold is reached.

In these tests the aim was to see how accurately the information gathered was presented, whether the displays were acceptable and to see if the users could interact easily with the system whether it was being displayed on a laptop or on the PDA. The aim for the interface on the PDA was to make it simple and easy to use. Once again three motes were placed around the testing room and a laptop was set up in the room as well. Please note this laptop could have been placed in remote environment if so desired. The research assistant opened an internet browser and started up MRTG and started the motes. The subject was then asked to start the PDA using a set of written instructions so that any user who was not familiar with the PDA could get the system working. The research assistant was in charge of changing the light in the room at certain intervals and the subject was asked to observe the graphs on both the laptop and the PDA. The subjects could also move around the room with the PDA and observe any changes as well as being able to leave the room with the PDA to see if there are any changes shown on the PDA. The subjects were asked to record their observations on a sheet of paper.

The following comments were received from the subjects. Please note the researcher has used the pronoun 'he' for all the subjects even though males and females were equally represented.

Subject A found "some technical issues with the mobility testing – not reflecting changes when moving" when using the PDA. He also reported "no problems transferring and reflecting changes on the

laptop side". In this testing setting the researcher noted that the motes were not transmitting the data to the PDA unless the PDA was static. Further investigation found that the motes were having difficulty finding the PDA as it was moved around the room.

Subject G made the following comments about the laptop system: "The graph showed an incorrect body temperature reading" and he felt that the "graphs are small". Despite these limitations he concluded that the system "technically seems Ok perhaps you need to improve the graphical interface". The researcher notes that obtaining correct body temperature with these motes is not really feasible as they are not designed for that – they are more suited to collecting ambient room temperature. This subject did not make any specific suggestions for improving the interface. When testing the PDA subject G suggested that "the program should be on the programs folder" and that the "the grapher needs labelling". He found the beeper annoying and recommended that the system needed "a stop button to stop the beeping". The lack of labelling on the graphs also proved to be a problem on the Laptop for Subject F who gave two suggestions: "making the light levels a percentage of full day light" and "better labelling on the graphs". When using the PDA, he suggested that it was not necessary to show further data other than "daily and possibly weekly graphs". The researcher notes that such daily and weekly readings would not be particularly helpful in a health or care giving facility particularly if the device was monitoring body temperature and even room temperature which may affect the health of the patient.

Subject A reported no issues with either the web interface or the PDA. No suggestions for improvements were made. However Subject C complained that the "logout" button on the PDA was not accessible and suggested the use of frames for the laptop interface.



Further summarized comments from a number of subjects included the following issues that need to be addressed in future work:

- graph weekly should show Week # for further reference;
- graph daily should show Day # for further reference;
- accelerometer should be continued on one graph if possible;
- user interface – show that there is a link to Daily, Weekly on the left menu underlying it;
- need to show the Motes numbers;
- stop beep- show Button that says STOP;
- looking at text version – a little more variation in the numbers – irritating message about ready to check room lighting.

## 7.4 Results and Discussion

The **System** evaluation showed that 62.5% selected from the range of “Too simple” to “Just right” in terms of functionality and usability, while 37.5% experienced “Some difficulty” or found the system “Too complex”. Seventy five percent (75%) of the users indicated that the overall performance of the **Test** evaluation was in the range of “Generally easy” to “Just right”, while 25% experienced “Some difficulty”.

As indicated above, further work is required to improve both the system functionality and the usability including:

- at present the size of MICA2 is not small enough or accurate enough to be used comfortably for body temperature measurements. It is not designed to measure body temperature but the experiments were designed to show fluctuations in temperature and it was felt that holding the motes or placing

them in the pockets of the subjects would give a variety of different readings;

- the motes did not always perform in terms of the specified range of coverage;
- the motes are difficult to handle specially because of the large antenna and battery pack;
- there are issues with the calibration of the sensors that, in some cases, led to false readings;
- lack of robustness of the motes;
- further long term testing is required to establish feasible battery life for a healthcare monitoring application.

## 7.5 Conclusion

The Stargate MoteCare represented a significant improvement over the previous prototypes. The database PostgreSQL is able to hold the structured data for long term storage adding to the capabilities of the MRTG system. The use of the Stargate server allowed for the development of a fully wireless monitoring system with the addition of 802.11. Stargate provided middle management distributed processing and storage capabilities to the system. The hardware upgrade to the mobile monitor with a new PDA improved the reliability of the system. A more intuitive and extensive user interface was developed. Security features in the form of user names and passwords were added to the system as well as the ability to use thresholds to enable the system to comply with the fault management requirements by setting alarms (beeps) if specific thresholds are reached.

However the researcher required actual medical sensors in order to fully test the hypothesis that Network Management tools could be used to monitor health parameters. In chapter 8 the author describes the setting up of the Medical MoteCare System which introduces new

hardware and software to ensure that medical data can be captured and properly displayed and interpreted.

# 8. The Medical MoteCare: The Adaptation of Three-Tier and Agent Server NM Models

*The doctor of the future will give no medicine but will interest his patients in the care of the human frame, in diet and in the cause and prevention of disease (Thomas Edison, <http://www.quotegarden.com/medical.html>).*

## 8.1 Introduction

As explained in Chapter 7, the previous work had illustrated that monitoring and interpretation of environmental data was feasible but, as the thesis aimed to test the viability of health monitoring using sensors and network management tools, the author incorporated a pulse oximeter sensor into the Medical MoteCare system. Actual health data is used in this system to show that NM tools can be used to assist in the development of a distributed personal healthcare system. Further, the author used these experiments to develop a generic network management framework for healthcare applications. In this Medical MoteCare system, the author had to introduce proprietary based systems as the open source software did not provide the level of sophistication required, however the author is able to prove that network management tools can add intelligence to a health monitoring system by measuring and correlating a number of signals and sending out alerts when specific undesirable events occurred.

The building of the Medical MoteCare system brings the integration and testing of specialized sensors for healthcare monitoring through the use of an enhanced version of the Harvard CodeBlue software suite, an SNMP Agent, and the NM tools iReasoning MIB browser, SysUpTime Network Monitor and Jaguar SX for scalability, performance improvement and correlation of data so that more than one variable can be monitored and alerts can be issued. In order to accomplish the improvements required, the researcher obtained a set of ZigBee motes from Crossbow and a set of pulse oximeter sensors from Harvard University. Pulse oximeters were utilized to measure heart rate and blood oxygen saturation. Light and temperature were still used in parallel for environmental monitoring as environmental conditions such as light and temperature can impact on the physical well being of a patient. The researcher obtained permission from Professor Matt Welsh of Harvard University to modify and extend the CodeBlue software as mentioned in Chapter 3 for integration into the Medical MoteCare system.

SNMP protocol was used in this system for the collection of the data via an SNMP agent. Three network management tools, the iReasoning MIB browser and the network monitoring and alarm systems SysUpTime Network Monitor and Jaguar SX from iReasoning Networks and ByteSphere® respectively, completed the setting up of this Medical MoteCare system which will be described in the following section.

## 8.2 Adaptation of Three-Tier and SNMP Proxy NM Organizational Models

The Medical MoteCare system (and the previously implemented Stargate MoteCare system) was based on the adaptation of the Three-Tier and SNMP Proxy Organizational Models. The SNMP Proxy enhancements enabled this system to improve the scalability, modularity and flexibility of the system by potentially bringing to the researcher or developer communities the freedom of selecting from a vast range of existing SNMP based NM tools to fit their specific WSN application requirements. The adapted the Three-Tier NM Organizational model can be seen in Figure 8.1.

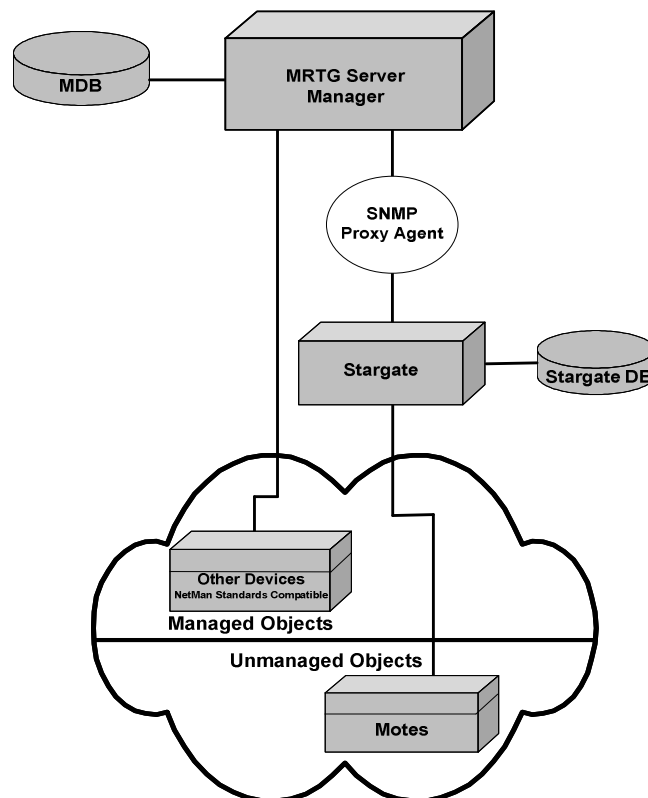

Figure 8.1 Adapted Three-Tier NM Organization Model to The Medical MoteCare System

The enhancements in the adapted Three-Tier NM Organization model with a tailored SNMP proxy agent shown in Figure 8.1 allow for the natural implementation of any SNMP-capable NM tool in the Medical MoteCare system. This makes the system not only capable of having more than one manager entity without the risk of over polling the managed devices, but also makes it platform independent by allowing SNMP standard communication with any number of NM systems acting as Manager, Middle Manager or Agent Entities.

### 8.3 General Architecture for the Medical MoteCare System

One of the additions to this system involves the use of medical sensors in order to test the feasibility of the system in dealing with medical data. The integration of an SNMP agent in conjunction with the CodeBlue Communication module enabled the system to be accessed via any network management tool that understands SNMP. This ensured that the system was able to scale up easily and provide a robust and well tested, standardised environment. Enhancements to the CodeBlue software were made by our research group in the mHealth laboratory at the University of Technology Sydney in order to incorporate the environmental sensors in parallel to the health monitoring. These will be explained in the following section (Messina et al, 2007; Messina et al, 2008; Lim et al; Fischer et al, 2008).

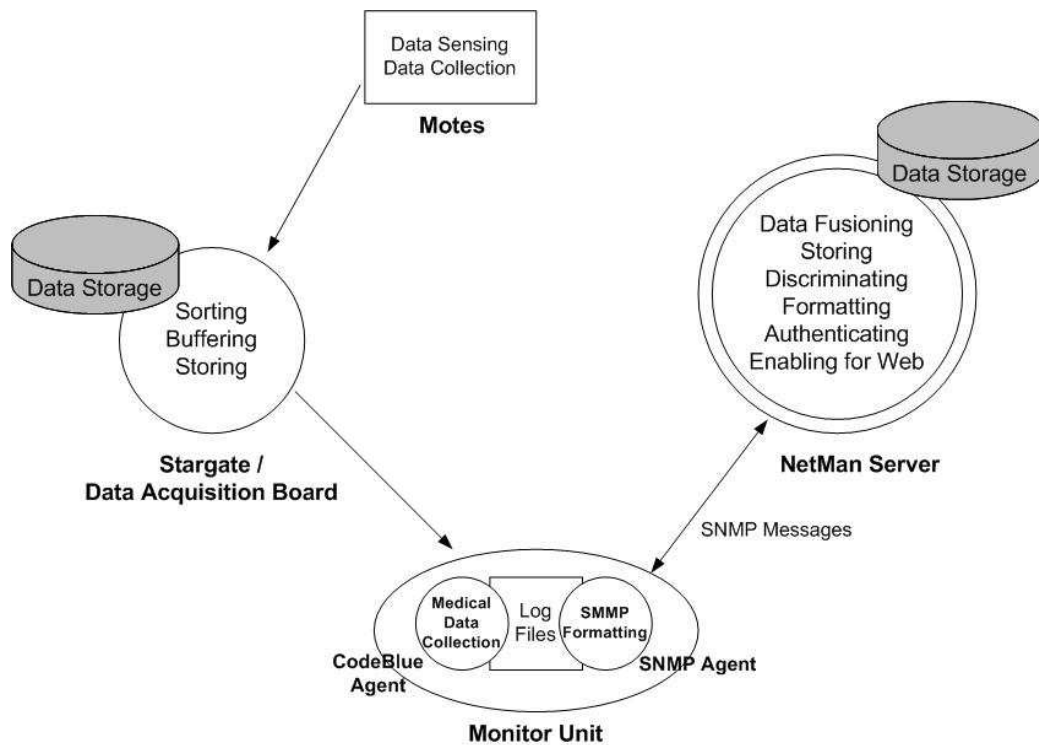

Figure 8.2 System Process Overview for the Medical MoteCare System

### 8.3.1 Motes

The WSN architecture of this prototype was based on MicaZ motes (Crossbow Technology Inc., 2005) which added robustness to the system communication (as a result of the use of the Zigbee protocol) instead of the Mica2 family of Motes which was used in previous systems. The MicaZ specifications are as follows (Crossbow Technology Inc. 2005) (Allick et al, 2006):

- IEEE 802.15.4, tiny, wireless measurement system designed specifically for deeply embedded sensor networks;
- 250 kbps, high data rate radio;
- wireless communications with every node having router capability;



- expansion connector for light, temperature, RH, barometric pressure, acceleration/seismic, acoustic, magnetic, and other Crossbow sensor boards.

Figure 8.3 shows a Mica Z Mote which has a more robust antenna than the Mica2 motes used in the earlier systems.

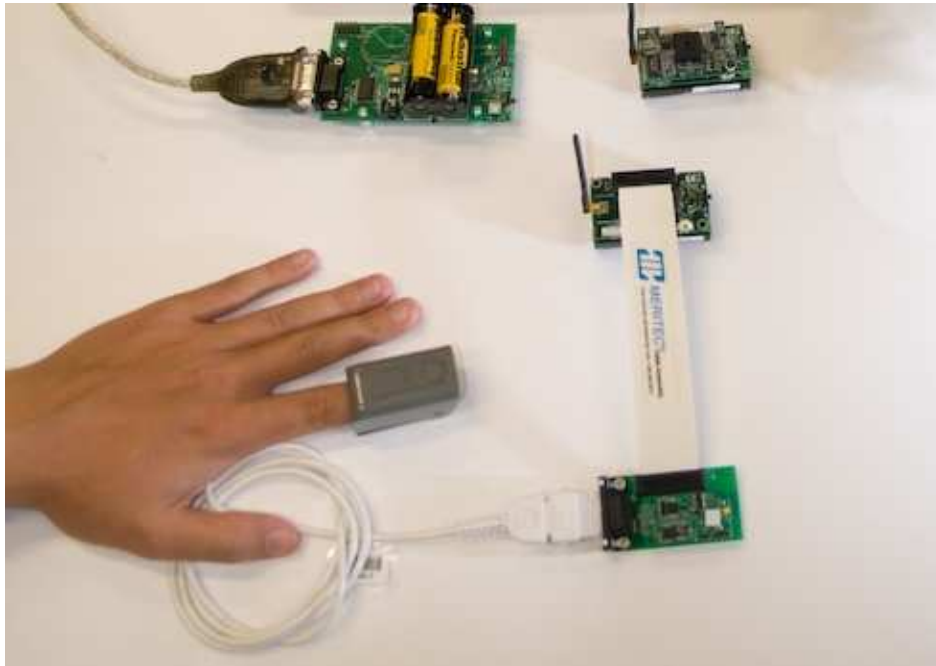

*Figure 8.3 MicaZ Mote (www.xbow.com)*

Three types of sensors were used on the motes, namely light, temperature and pulse oximeters. The author acknowledges the assistance of the ReMoteCare Team (whose names appear in the Acknowledgement section of this thesis) at the University of Technology for their assistance in the building of this system.

### **8.3.2 Pulse Oximeters**

The first sensor is the Pulse Oximeter, a medical sensor from BCI, Inc. (see Figure 8.4) consisting of a standard finger or ear sensor, a pulse oximetry module (BCI Micro Power Oximeter board) and a mote (Messina et al, 2008) Blood oxygen saturation (SpO<sub>2</sub>), pulse and plethysmogram waveform data are relayed via a serial interface to the MicaZ node. The pulse oximeter mote device periodically transmits packets containing the measured samples.



*Figure 8.4 The Pulse Oximeter*

### **8.3.3 Environmental Sensors – Light and Temperature**

The MTS310CA, flexible sensor board, has a number of sensors such as light and temperature which are incorporated into the Medical MoteCare system. As explained in the building of MoteCare, Mobile MoteCare and Stargate MoteCare systems, temperature readings were integral to the testing so the author decided to incorporate them into the Medical MoteCare system for consistency and to illustrate the potential importance of environmental impacts on the physical condition of a monitored patient. For example, an elderly person might be complaining that the light in the room is affecting her ability to read. The light sensor can prove that the light is appropriate and that maybe this person needs her eyes tested. Alternatively, if a person who has suffered a heart attack recently, suddenly starts sweating, the symptoms could signal another attack or it may be that the room is too hot.

**Data Acquisition Board: Stargate Personal Server**

The Data Acquisition Board is the Stargate Personal Server processing board which has been explained in Chapter 5, Section 5.5 which has detailed technical specifications and in Chapter 7, in the building of The Stargate MoteCare system.

**Monitor Unit**

The Monitor Unit comprises the enhanced CodeBlue software that incorporates log files of data recordings captured by the sensors on the MicaZ motes and an SNMP agent to enable it to deal with standardized network communication using the SNMP protocol (for technical specifications see Chapter 4, Section 4.2.2). The Monitor Unit connects to the Gateway Mote either via a USB connection, a serial connection or Internet Protocol (IP).

**CodeBlue Component with SNMP Agent**

On the Monitor Unit side CodeBlue captures the data and stores it locally on log files. It is then sent through an SNMP agent after a request is made by the Network Management Server. The CodeBlue system with the incorporated SNMP agent provides access to the widely accepted TCP/IP protocol suite. As motes have extremely limited processing power, battery life and transmission budgets, SNMP was not implemented on the motes themselves as the additional overhead would have dramatically reduced battery life (Lim et al, 2008). The MoteCare communication protocols utilized on this component are found in table 8.1

*Table 8.1 Solutions for Communications*

ZigBee/802.15.4 physical and data link layer solutions

CodeBlue Adaptive Demand-Driven Multicast Routing (ADDMMR) to provide layer 3 routing and connectivity without the use of TCP/IP.

As has been demonstrated in the MoteCare, Mobile MoteCare and Stargate MoteCare systems the WSNs have been connected to devices such as PCs and PDAs for data collection and system monitoring. These devices are capable of using TCP/IP. In the Monitor Unit of the Medical MoteCare system, using the CodeBlue component, an SNMP agent was set up to act as an IP-based Data Delivery Unit (DDU). The DDU is able to act as an agent and deliver information collected on the WSN into a TCP/IP based network (Lim et al, 2008).

In keeping with the philosophy of the researcher to utilize as much existing and freely available code and protocols as possible, several Object Identifiers (OIDs) from RFC 1213 were used for the Medical MoteCare system (see Table 8.2). As previously explained in chapter 4, an object identifier is an identifier used to name an object. Structurally, an OID consists of a node in a hierarchically-assigned namespace, formally defined using the ITU-T's ASN.1 standard. Successive numbers of the nodes, starting at the root of the tree, identify each node in the tree. Designers set up new nodes by registering them under the node's registration authority (Wikipedia, 2007) (Anon, 2008). Refer to chapter 4 for more information on OIDs. The researcher used standard and customized MIBs for the Medical Motecare system as set out in Table 8.2. The customized MIB was developed by the mHealth team at UTS creating specific OIDs for the polling of health and environmental data from the WSN nodes (Fischer, 2008).

*Table 8.2 Object Identifiers Used for The Medical MoteCare*

<b>OID</b>	<b>Variable Name</b>	<b>Utilized for</b>
1.3.6.1.2.1.2.2.1.1	ifIndex	mote ID as number
1.3.6.1.2.1.2.2.1.2	ifDesc	mote ID as string (mote-xx)
1.3.6.1.2.1.2.2.1.6	ifPhysAddress	mote ID as hex value

1.3.6.1.2.1.2.2.1.10	ifInOctets	pulse sensor value
1.3.6.1.2.1.2.2.1.11	ifInUcastPkts	light sensor value
1.3.6.1.2.1.2.2.1.16	ifOutOctets	oxygen sensor values
1.3.6.1.2.1.2.2.1.17	ifOutUcastPkts	temperature sensor values

**SNMP Agent**

In order to enable standardized communications between Medical MoteCare and more robust Network Management tools (rather than MRTG which had been used in the previous MoteCare, Mobile MoteCare and Stargate MoteCare systems) the researcher incorporated an SNMP agent. Furthermore the development of more sophisticated SNMP versions such as SNMPv3 allows for more security which is important when dealing with medical data.

The benefits of SNMPv3 for the Medical MoteCare system are that data can be collected securely from SNMP devices without the fear of the data being tampered with or corrupted. This is vital in any healthcare system. As well, confidential information, for example, the SNMP Set command packets that change a router’s configuration, can be encrypted to prevent its contents from being exposed on the network. Refer to Table 8.3 for SNMPv3 features.

*Table 8.3 SNMPv3: Features for Network Management*

Interoperable	
Standards-based	
Secure Access	Authentication Encryption Message Integrity

In MoteCare, Mobile MoteCare and Stargate MoteCare systems as explained in Chapters 6 and 7 the author used scripting language to communicate with the processor board and the Stargate. This decision was based on the premise that the motes did not speak SNMP. However MRTG allowed the researcher to use a script to overcome this issue as explained in Chapter 6. The author realised that if the motes could utilise the much more widely used SNMP, the Medical MoteCare system would be capable of far wider distribution and would be more robust.

The incorporation of the SNMP agent to the MoteCare Monitor Unit was facilitated by the use of SNMP4J, an enterprise class, free open source and up-to-date SNMP implementation for Java (Fischer, 2008). The researcher therefore utilized an agent derived from the SNMP4J standard example which provided a static SNMP table to hold the sensor data and allow for SNMP requests. (Lim et al, 2008)

### ***Log Files***

The log file is used to communicate between the CodeBlue component and SNMP agent in the Monitor Unit. The structure of the files consists of time and data stamps, Mote/patient ID and sensors available. The standard format is as below:

**<date stamp> <time stamp> : <Mote/patient ID number type of sensor= data from the sensor>**

An example is set out below:

**<14 Jan 2008 10:25:16.939 EST : <patientID= 102PULSE= 92>**

Upon detection, the motes will continuously send data from the sensors with IDs on a first come, first served basis. After the motes are detected, data with an ID code are sent and logged into the Monitor Unit (Lim et al, 2008).

***Network Management Server***

The use of open source materials is a feature of the systems developed by the researcher as explained in Chapters 6 and 7. However, the available open source network management tools did not provide the level of sophistication required for this Medical Motecare system which collects medical data and must be able to react to specific and variable correlated thresholds. Therefore the researcher decided to use commercial software in the form iReasoning MIB Browser for MIB browsing and MIB customization and SysUpTime Network Monitor and Jaguar SX for alert configuration and event correlation. Details of these software applications are found in the following sections.

***iReasoning MIB Browser and SysUpTime Network Monitor***

iReasoning MIB browser is a powerful and easy-to-use tool powered by iReasoning SNMP API . Its features include a component to manage SNMP enabled network devices and applications. It allowed the researcher to load standard and proprietary MIBs for the Medical MoteCare system and issue SNMP requests to retrieve agents' data, or make changes to the SNMP agent.

See Figure 8.5 for a screen shot of the iReasoning MIB Browser which will be explained in the section describing the implementation of the Medical MoteCare system.

## 8. THREE TIER AND SNMP PROXY NM MODELS

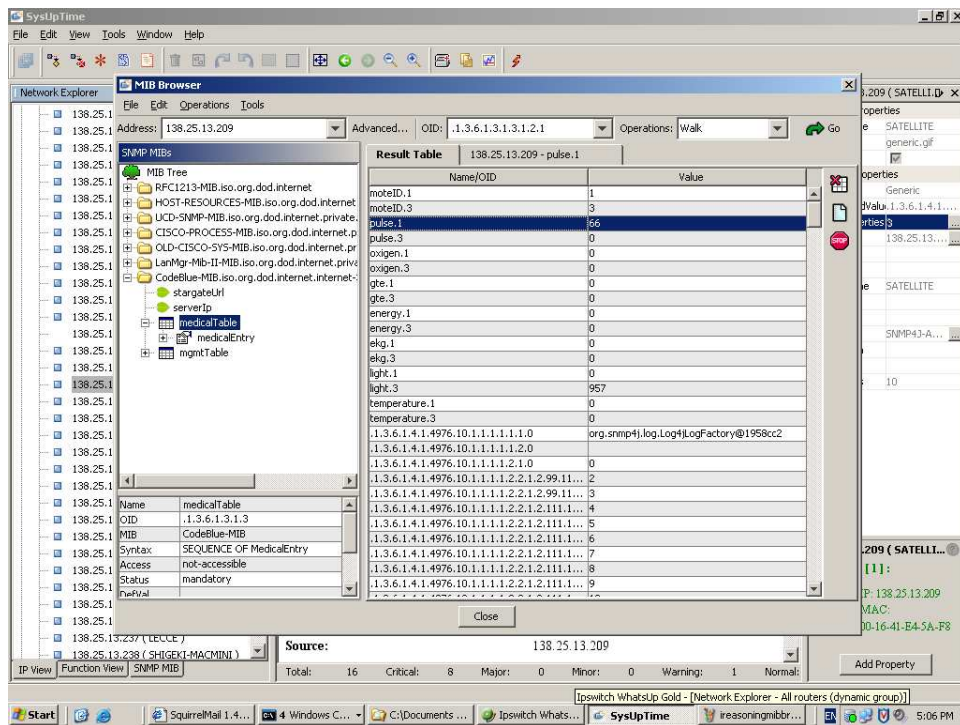

Figure 8.5 iReasoning MIB Browser

With iReasoning MIB Browser, all network information is stored in a relational database such as FirebirdSQL, PostgreSQL or SQL Server to enable easy and efficient device management and reporting. In a similar manner, the data monitored from the wireless sensor based healthcare application will be stored in such a database to facilitate its manipulation and provide secure storage, discrimination and fusion of data as specified as a requirement of such a healthcare monitoring system.

The SysUpTime Network Monitor can alert network administrators or, in the Medical MoteCare implementation, the health carer, by email, sound, the running a script, or triggering as well as taking corrective actions such as executing remote Windows/Linux commands. The data is stored in a relational database that can be accessed via the Internet. Refer to Figure 8.6 for a graphical overview of SysUpTime Network Monitor.



## 8. THREE TIER AND SNMP PROXY NM MODELS

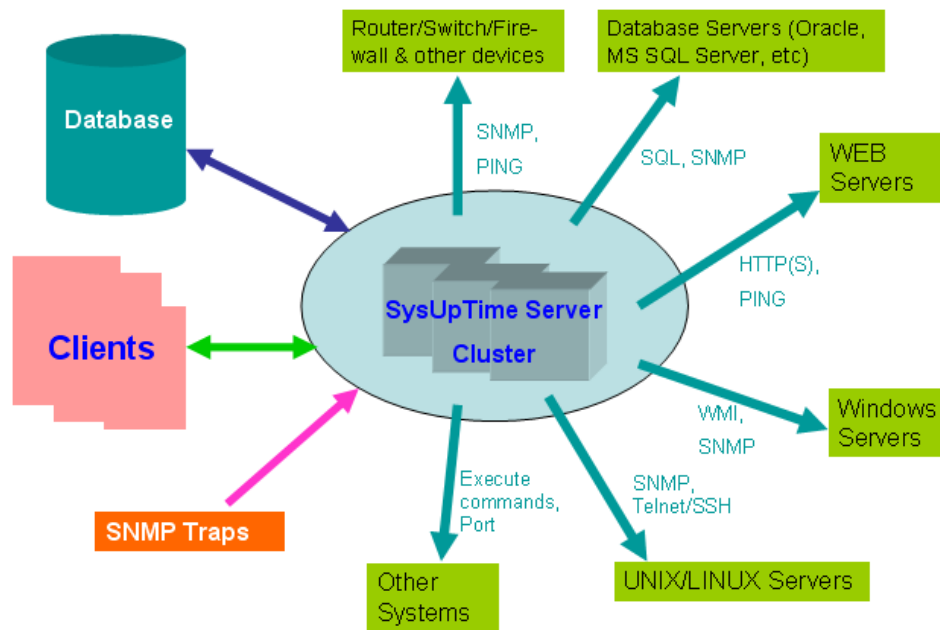

Figure 8.6 Overview of SysUpTime Network Monitor  
(<http://www.ireasoning.com/sysuptimeoverview.shtml>)

Using SysUpTime Network Monitor as a NM tool further illustrates the flexibility of using a variety of NM software packages in the Medical MoteCare system. Figure 8.7 illustrates the user interface of SysUpTime Network Monitor. In the Performance Graph section of the screen shot, the heart rate of the subject is shown increasing and decreasing in value – the horizontal line indicates the pre-set threshold that will ensure that a warning is given once the threshold is reached. The remote SNMP agent properties are displayed on the right hand side of the screen and show the OID 1.3.6.4.1.4976 that corresponds to the pulse oximeter sensor on the mote as well as the name and IP address of the host (Satellite and 138.25.13.209 respectively) where the agent is residing. It also shows the SNMP version number.

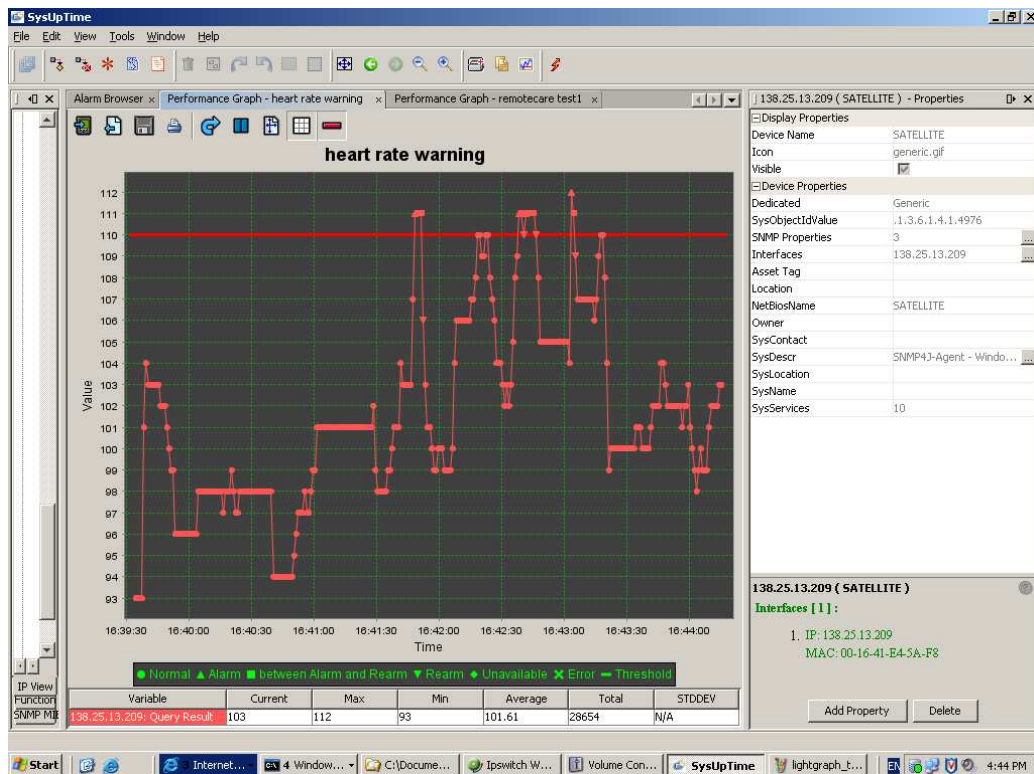

Figure 8.7 SysUpTime Network Monitor

As can be seen in Figure 8.7 the Medical MoteCare system using the NM tools iReasoning MIB Browser and SysUpTime Network Monitor was able to display medical data in graphical form in real time as well as provide alarm triggering. However the author wanted to illustrate some of the data fusion aspects of NM tools by implementing correlation of medical data and alarm triggering and for that the author used the NM tool Jaguar SX. This will be further discussed in the following section.

## 8.4 Multiple Variable Event Correlation

Event correlation techniques embedded in various network management tools are expected to allow for the development of personalized applications, specific to certain health conditions. Current techniques such as Rule-based reasoning (RBR), Code-based reasoning

(CBR) and Case-based reasoning (Subramanian, 2000) are utilized to add intelligence to system and network management tools by correlating variables and prioritizing them based on thresholds for labelling, various algorithms and hierarchical structures associated to them. For instance if a sufficient number of “events” in the system are triggered at the same time, e.g. temperature of the person and temperature on the environment, the system will check correlation and prioritize in order to trigger an alarm/message/action (Felix Navarro et al, 2006).

The NM tool Jaguar SX was implemented in the Medical MoteCare prototype with the purpose of adding intelligence to the system by making use of network management correlation techniques to interpret multi-variable collected data and automatically react or prevent harmful health conditions. The system was tested for alarm triggering functionality. Figure 8.8 shows a partial view of the Jaguar SX Monitor Exceptions window in which the multi variable alarm triggering conditions are configured. The compared values and conditions from variables identified by Object ID on column five can be correlated by grouping them into the same Object Group in column four. In order for Jaguar SX to trigger an alarm or notification, all the compared value conditions with the same Object Group have to be “True” (refer to Compare Value and Compare Type on columns six and seven).

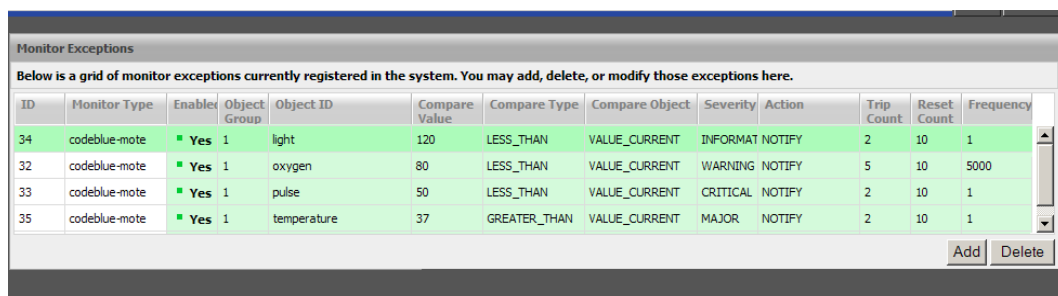

Monitor Exceptions

Below is a grid of monitor exceptions currently registered in the system. You may add, delete, or modify those exceptions here.

ID	Monitor Type	Enable	Object Group	Object ID	Compare Value	Compare Type	Compare Object	Severity	Action	Trip Count	Reset Count	Frequency
34	codeblue-mote	<input checked="" type="checkbox"/> Yes	1	light	120	LESS_THAN	VALUE_CURRENT	INFORMAT	NOTIFY	2	10	1
32	codeblue-mote	<input checked="" type="checkbox"/> Yes	1	oxygen	80	LESS_THAN	VALUE_CURRENT	WARNING	NOTIFY	5	10	5000
33	codeblue-mote	<input checked="" type="checkbox"/> Yes	1	pulse	50	LESS_THAN	VALUE_CURRENT	CRITICAL	NOTIFY	2	10	1
35	codeblue-mote	<input checked="" type="checkbox"/> Yes	1	temperature	37	GREATER_THAN	VALUE_CURRENT	MAJOR	NOTIFY	2	10	1

Add Delete

Figure 8.8 Partial View of Jaguar SX Monitor Exceptions Window

## 8.5 The Medical MoteCare System Description

In Figure 8.9 below the implementation of The Medical MoteCare System is illustrated.

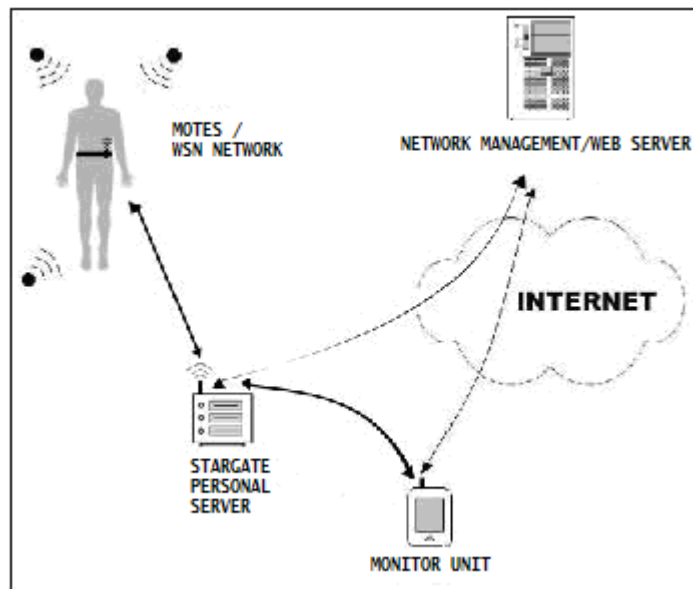
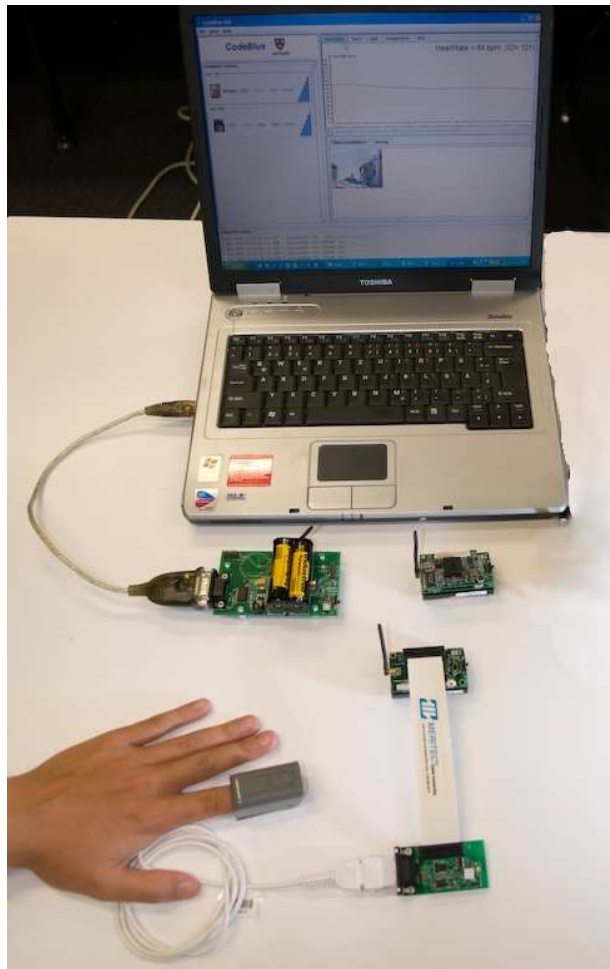

Figure 8.9 System Overview for the Medical MoteCare System

For the implementation of Medical MoteCare the researcher set up the system as follows. A subject was fitted with pulse oximeter device which was connected to the sensor board on the mote via a serial cable. As the data are being collected it is sent wirelessly to the Stargate Personal Server. The Stargate then sends the data through an Ethernet port to the Monitor Unit where it is stored in the form of log files created by the CodeBlue component. This step enables the agent to access the collected data and transform it into a SNMP format which makes it accessible to any network management tool that is SNMP compatible for instance with iReasoning MIB Browser, SysUpTime Network Monitor, Jaguar SX or any other commercialized or open source network management tool.

The advantages of this implementation for the Medical Motecare system include the following (Lim et al, 2008):

- bridges non- TCP/IP based networks to TCP/IP enabled networks via SNMP;
- polls the SNMP agent thus minimizes traffic on the WSN;
- allows for multiple SNMP agents to talk to multiple SNMP managers;
- supports encryption and end-to-end point security (SNMP v3);
- enables authentication to enable layered data access for security and privacy;
- utilizes the improved ZigBee protocol;
- provide extensive data storage facilities;
- allows for ease of scalability;
- enables analysis for trend spotting;
- facilitates the reactive capabilities when defined thresholds are reached;
- enables data correlation and fusion from data gathered via a variety of sensors.



*Figure 8.10 The Medical MoteCare Showing the Pulse Oximeter, the Stargate Data Acquisition Board, a Light Sensor Mote and the Monitor Unit*

## 8.6 Scenario Setting

In this section, the author describes a typical clinical scenario that serves for the testing and simulation of the system. A middle aged woman has recently recovered from the after-effects of a severe car accident. She had to spend two months in hospital and has now returned to her home. She immediately began to experience flashback and panic attacks as she relived her accident. The doctor suspected tachycardia and suggested she wore a pulse oximeter while resting during the afternoon and at night so that he can monitor her condition and ascertain whether the medication he has prescribed is succeeding

in regulating her heart rate. The doctor has asked her to use the pulse oximeter for one week so that he can establish enough evidence to decide whether he needs to change her medication or test for other conditions such as Wolff Parkinson White syndrome. Wolff-Parkinson-White syndrome (WPW) represents an abnormality of the heart's electrical system. In patients with WPW, there is an extra electrical connection between the atria (the upper chambers) and the ventricles (the lower chambers). This abnormal electrical connection can cause episodes of rapid heart rhythms called paroxysmal atrial tachycardia, preexisted tachycardia, or preexisted atrial fibrillation (Medicinenet, 2007). The aim of the monitoring is to ascertain if the heart rhythm reverts to normality during this week of monitoring and medication.

## 8.7 Testing

In order to test the above scenario in a laboratory setting the author set up the following implementation using five (5) subjects to test the Medical MoteCare system (refer to Figure 8.10). The subjects ranged in age from 20 to over 60 years old.

With the testing the author was attempting to establish that the system would detect the variations in the heart rate and blood oxygen levels as if the monitored person was starting to experience a panic attack. The system would send a critical alarm via a red flashing screen and an email to the carer notifying him/her that a particular threshold was reached. The author tested the system on five subjects performing a variety of activities that would force changes in the heart rate whilst connected to the system in a laboratory setting as described below.

The system captured the readings of the heart rate and blood oxygen levels as the subjects carried out the different activities. Furthermore

the system was expected to react to predefined thresholds and alert the carers to potential problems. The system was able react to a series of correlated thresholds – for example if the heart rate is over a particular threshold but the blood oxygen level is normal a warning notification is generated whereas if the heart rate is high and the blood oxygen is low a critical alarm is produced.

## 8.8 Experiments to Simulate Increased Heart Rate

In this scenario, two subjects were each attached to a pulse oximeter and given the following instructions. For the first minute they had to sit calmly whilst the resting heart rate figure was established. They then were asked to stand and walk on the spot slowly whilst still attached to the system. Pulse Oximeters are supposed to be used on a patient at rest but to increase the heart rate artificially, the researcher had the subjects walk quickly on the spot. At the end of these two minutes they were instructed to walk quickly for two minutes. The graph in figure 8.11 below shows the changes in the heart rate with the threshold marked to show when the system was to react – in this case, for the purposes of testing, the figure of 110 bpm was selected.

The results of the experiments are illustrated in the following screen shots and samples of the actual data collected is found in Appendix A. Figure 8.11 illustrates the results of one experiment where the heart rate went over the 110 bpm and the alarm trigger screenshot is shown in Figure 8.12.



## 8. THREE TIER AND SNMP PROXY NM MODELS

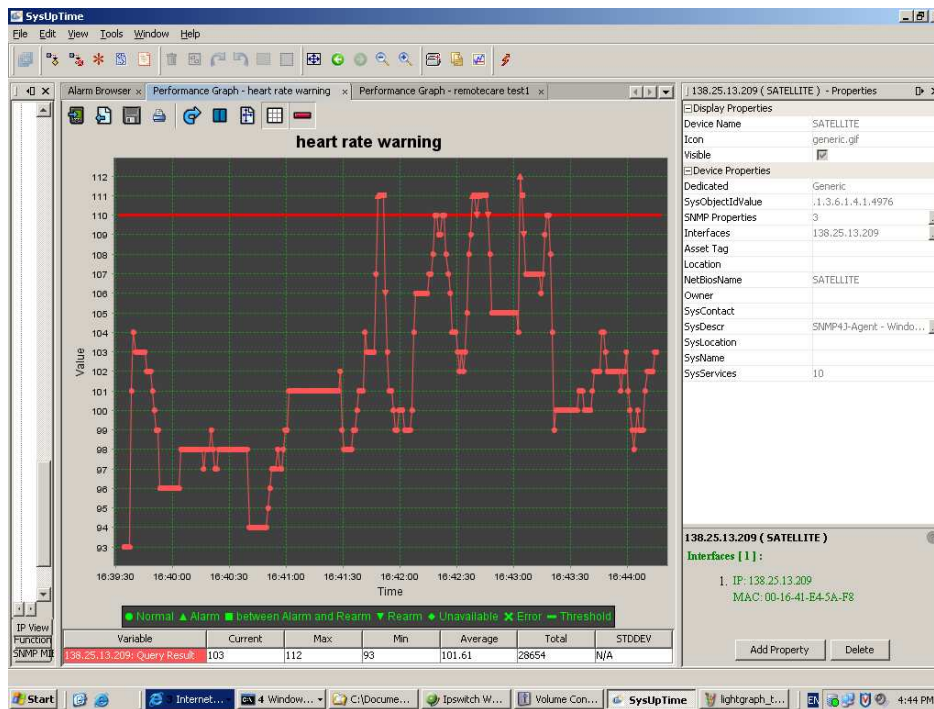

Figure 8.11 Graph from iReasoning MIB Browser

In Figure 8.12 a list of triggered alarms, illustrating different levels of severity, is shown. In the top row alarm, a critical event, highlighted in red, is shown. Column Severity can indicate "Critical", 'Normal' or "Warning". The next column indicates the IP address of the Source where the event was polled. Time and Date stamps are indicated in the next columns and in the last column, the current value of the heart rate plus a description of the alarm is located.

## 8. THREE TIER AND SNMP PROXY NM MODELS

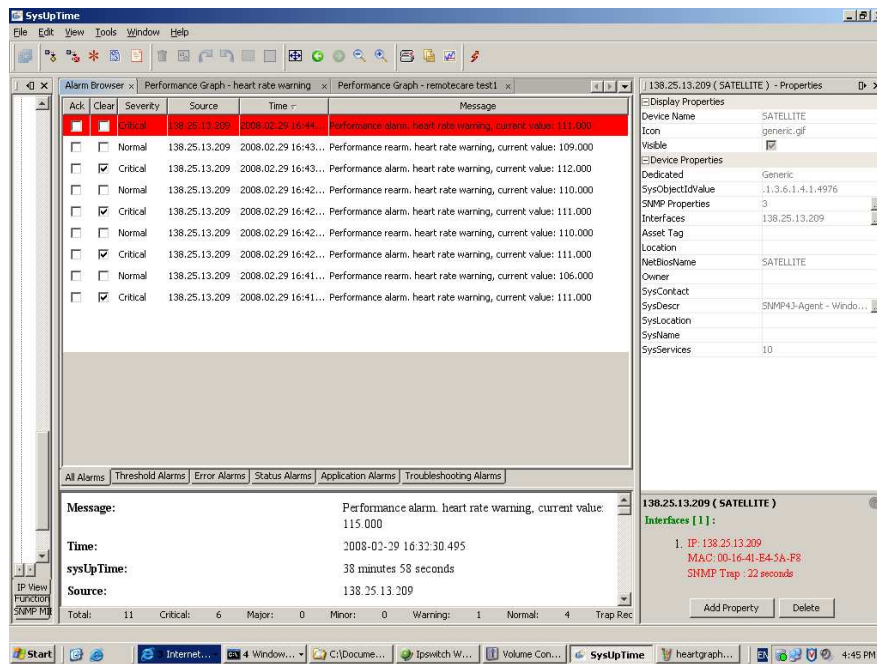

Figure 8.12 SysUpTime Network Monitor Alarm Triggering

The screen shot of Figure 8.13 shows the Simple Mail Transfer Protocol (SMTP) configuration window used by SysUpTime Network Monitor to send email alerts once a preset threshold has been reached.

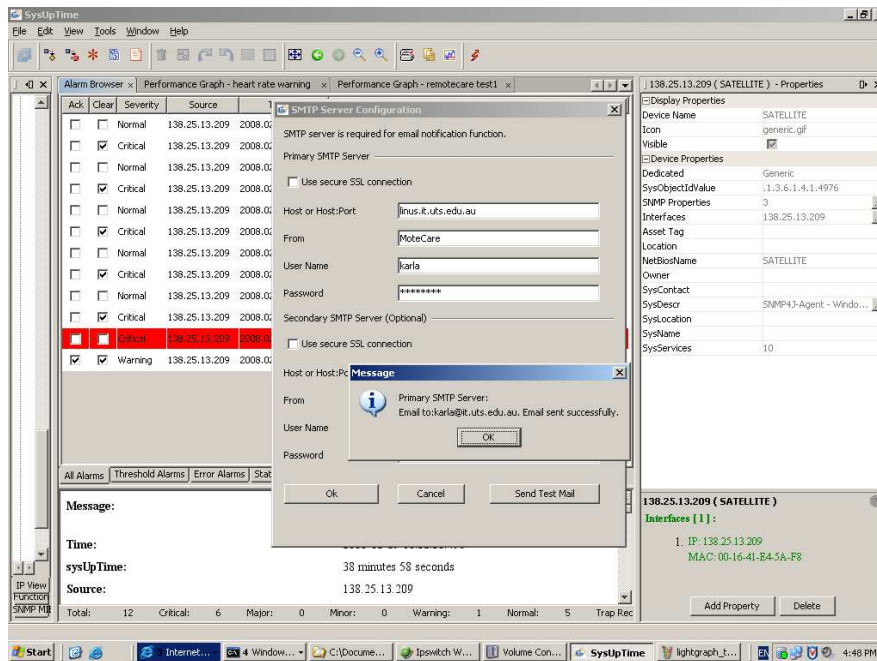
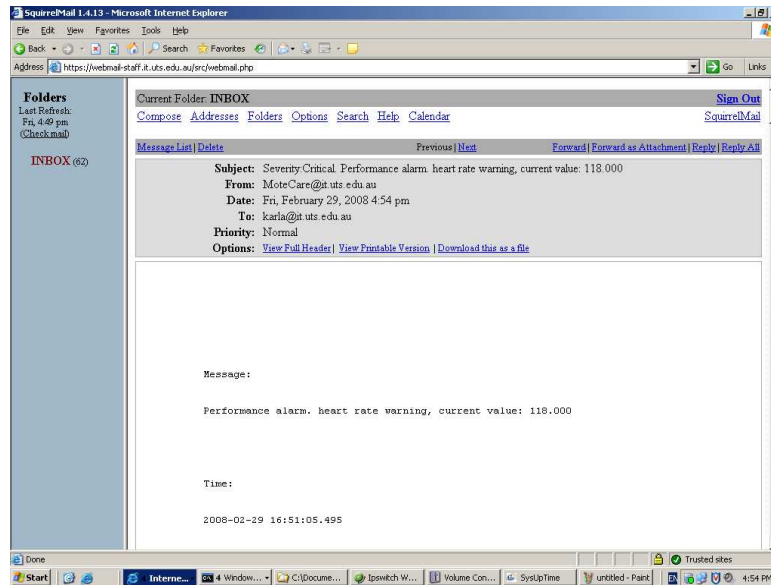

Figure 8.13 SysUpTime Network Monitor Email System Alert

Figure 8.14 shows the email sent to the carer indicating that a heart rate warning has been triggered and shows the current heart rate value (in this case 118 –well over the threshold of 110 bpm)



*Figure 8.14 SysUpTime Network Monitor Email System Alert Scenario to Simulate Increased Heart Rate*

The author was able to demonstrate that the Medical MoteCare was capable achieving the requirements of monitoring healthcare variables via network management tools. However to make the system more robust and useful the author had to utilize Jaguar SX to demonstrate event correlation for more than one healthcare variable.

## 8.9 Data Fusion with NM Event Correlation

The Medical MoteCare system implemented Jaguar SX by incorporating the tailored ReMoteCare MIB in the system engine of Jaguar SX and by performing the appropriate discovery and polling of the medical and environmental motes via the SNMP proxy. See Figures 8.15 for a view of the discovered system devices via Jaguar SX and refer to Figure 8.15 for a graphical view of the collected medical data in real time.

## 8. THREE TIER AND SNMP PROXY NM MODELS

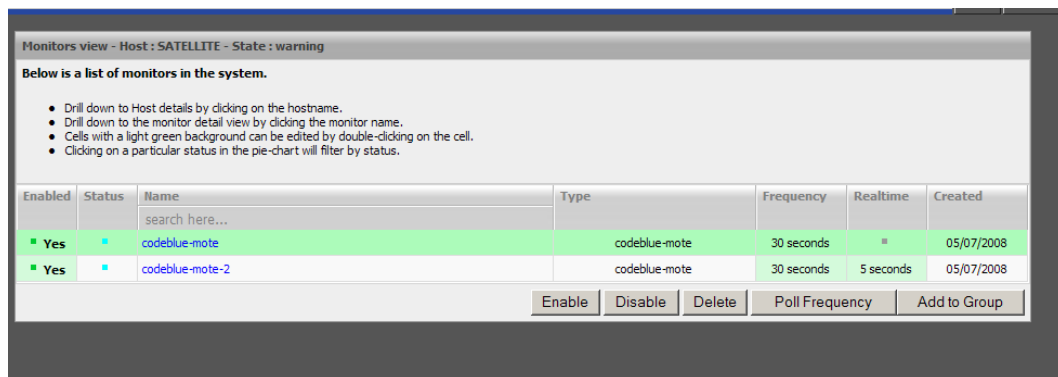

Figure 8.15 Jaguar SX WebUI Discovery of the Motes

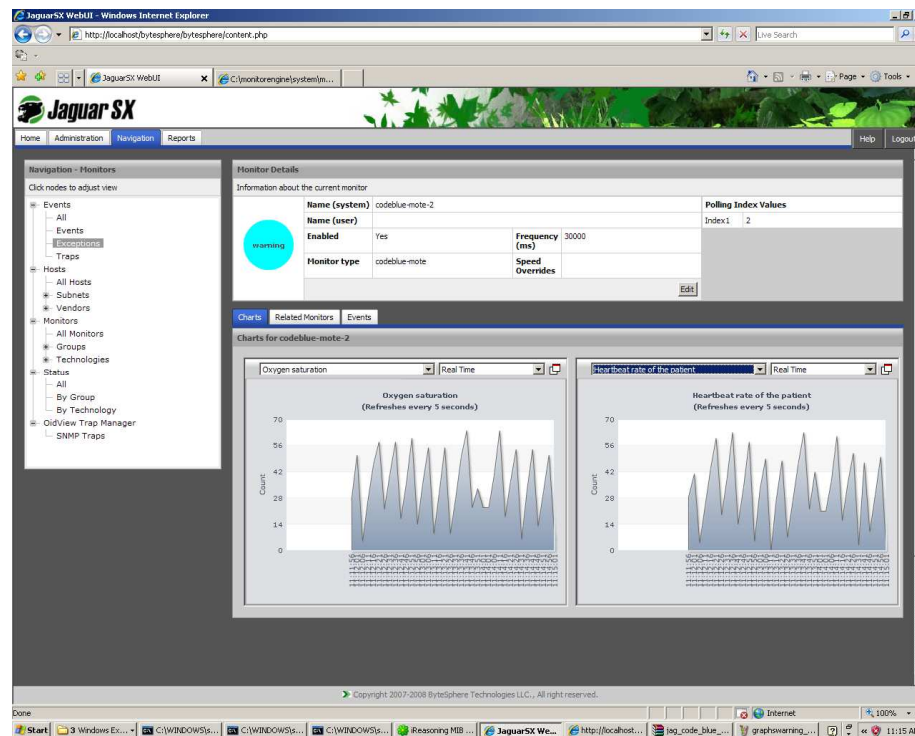

Figure 8.16 Jaguar SX WebUI Data Collection of Heartrate and Oxygen Level in Real Time

As can be seen in Figure 8.16, both blood oxygen level and heart rate measurements are being measured in real time with the showing graphs being refreshed every five seconds.

The Monitor Exceptions module of Jaguar SX was used to setup the conditions for multiple variable event correlation. As can be seen from Figure 8.167 the monitor exceptions from the variables oxygen, pulse, light and temperature have been configured to trigger an alarm in the event of their preset conditions, corresponding to the "Compare Values" in column six and "Compare Types" in column seven.

ID	Monitor Type	Enabled	Object Group	Object ID	Compare Value	Compare Type	Compare Object	Severity	Action
34	codeblue-mote	Yes	1	light	120	LESS_THAN	VALUE_CURRENT	INFORMAT	NOTIFY
32	codeblue-mote	Yes	1	oxygen	80	LESS_THAN	VALUE_CURRENT	WARNING	NOTIFY
33	codeblue-mote	Yes	1	pulse	50	LESS_THAN	VALUE_CURRENT	CRITICAL	NOTIFY
35	codeblue-mote	Yes	1	temperature	37	GREATER_THAN	VALUE_CURRENT	MAJOR	NOTIFY

Figure 8.17 Jaguar SX WebUI Monitor Exceptions Configuration Page

The alarm triggering is colour coded depending of its level of criticality, for example a critical alarm is bright red whereas a minor or warning alarm is coloured yellow or blue respectively (Figure 8.18).

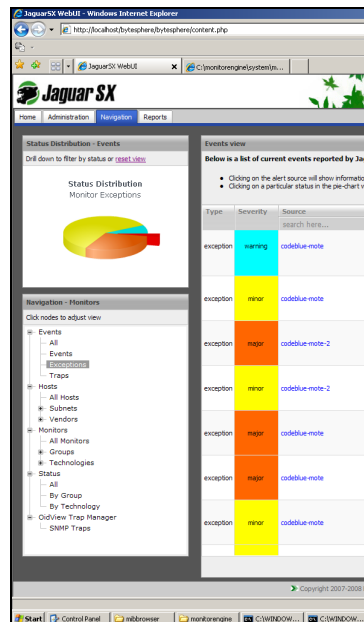

Figure 8.18 Jaguar SX Alarm Triggering for Heart Rate & Oxygen Level

## 8. THREE TIER AND SNMP PROXY NM MODELS

As can be seen in Figure 8.19, the Medical MoteCare system triggering alarm module from Jaguar SX window shows a diverse set of alarm notifications generated from previously preset multi-variable conditions.

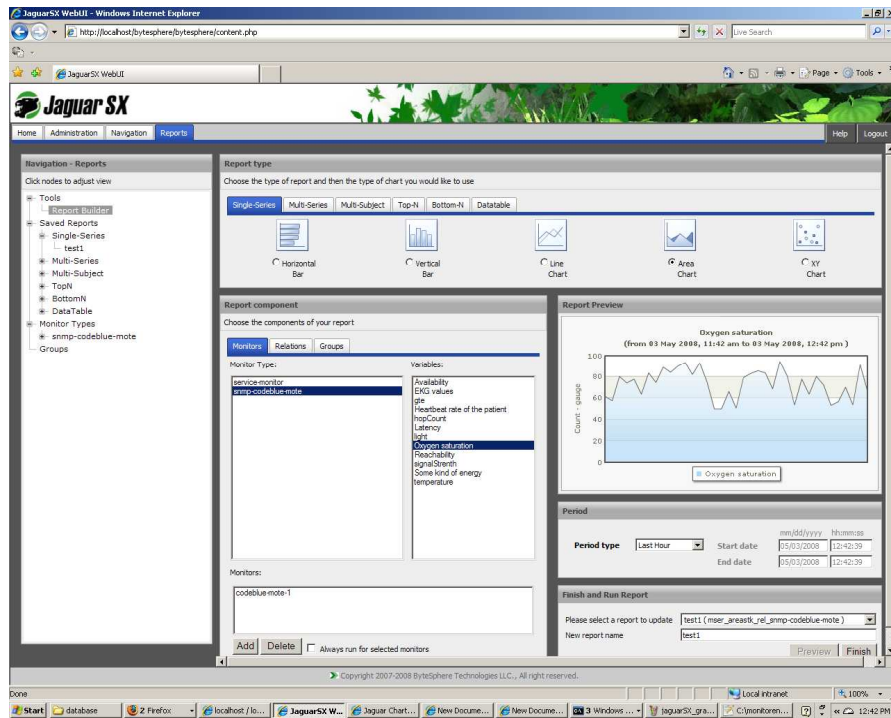

Figure 8.19 Jaguar SX Reports Module for Oxygen Saturation

To further illustrate the versatility of the system, the author was able to display the Medical MoteCare system on a PDA. This would enable carers to move around while still being able to monitor patients remotely (Figure 8.20).



Figure 8.20 Mobile Medical MoteCare

## 8.10 Conclusion

The Medical MoteCare system represented a significant improvement over the previous prototypes. First, the incorporation of medical sensors to the prototype allowed for the feasibility testing of the system for the handling of medical data. Second, the use of an SNMP agent and a tailored MIB enhanced the scalability, modularity and flexibility of the system by potentially bringing to the researcher or developer communities the freedom of selecting from a vast range of existing SNMP based NM tools to fit their specific WSN application requirements. The latter was exhibited by the implementation and testing of NM tools of varied complexity and purpose, namely iReasoning MIB Browser, SysUpTime Network Monitor and Jaguar SX.

The Medical MoteCare System developed is a proof of concept that the use of standard network management tools, in this case, iReasoning MIB browser, SysUpTime Network Monitor and Jaguar SX, can assist in the development and implementation of robust distributed, wireless sensor networking applications for monitoring healthcare parameters for patients. These NM tools and, consequently any other NM tool that utilizes SNMP NM standard protocol, can be successfully integrated into WSN applications, and, in this case, of a personal health care monitoring nature.

The implementation of Jaguar SX added intelligence to the system by utilizing NM correlation techniques to interpret the collected events automatically and react, or sometimes even anticipate from the collected statistical data, harmful health conditions. It must be reiterated that the open source NM tools were not sufficiently robust to enable the Medical MoteCare system to work as required and thus the researcher had to utilise proprietary NM software tools for this Medical MoteCare system. This will be discussed under the limitations of the system in Chapter 9 which follows. In Chapter 9, the researcher will present the HealthCare Framework as developed as a result of this work and will present conclusions and point the way to further research.



# 9. Heterogeneous Framework and Conclusions

## 9.1 Introduction

In this concluding chapter the researcher discusses and maps the contributions of the research in relation to the hypotheses set out in Chapter One. It summarises the main findings, and presents them in the form of a generic framework that can be adapted for healthcare monitoring. It is hoped that such a framework will assist future researchers to progress this important social and technical area of research. Finally it outlines the strengths and weaknesses of the research.

As explained in Chapter 1 of this thesis, one research objective of this work aimed to show that accepted and proven Network Management techniques are suitable for the development of Wireless Sensor Network (WSN) Personal Healthcare applications such as monitoring a patient's temperature, heart rate and blood oxygen level. Another research objective was to develop a generic framework based on accepted and proven Network Management models suitable for the development of WSN Personal Healthcare applications. The framework was derived from various disciplines, namely WSN technologies, medical healthcare monitoring systems, and network management models and tools. It presents guidance in the application and adaptation of previous well established models and technologies such

as network management systems into the development of WSN applications for personal healthcare monitoring.

This thesis is the product of the work done during the initial literature review, analysis and planning of the MoteCare project, as well as the functional aspects relevant to the building and testing of the evolving systems. The researcher strengthened the areas that were exposed through the prototyping phases to either improve the effectiveness in the functioning of the system or to enhance its usability. These systems were developed based on the NM OSI Functional model and by adapting the Two-Tier, Three-Tier and Agent Server NM Organizational models which, in conjunction, form the theoretical underpinning of this research. The OSI Functional model was used to form the basis of the MoteCare health monitoring systems by adapting its fault, performance and security management functional branches for the transportation and monitoring of medical data.

The holistic framework visualized aided the grounding of the development of the MoteCare, Mobile MoteCare, Stargate MoteCare and Medical MoteCare systems. To aid to the readability of this chapter the 'MoteCare project' will be used to refer to each and all of the different developed systems.

The details of the developed framework are presented and explained in the following section. Recommendations and future areas of research on each of the layers of the architecture are also presented in section 9.7 of this document.

## 9.2 The NM-WSN Application Development Framework Overview

The development of the proposed framework follows two major stages. The first stage investigates and correlates the two focal areas of research of the proposed MoteCare project, namely WSN based Personal Health Care Applications and Network Management Systems. This stage comprises the corresponding literature reviews of these two key areas of knowledge and the identification of the intersecting general application requirements and functional principles between them. The systems development methodology was applied at this stage for systems requirement identification, including the interfacing features of the system.

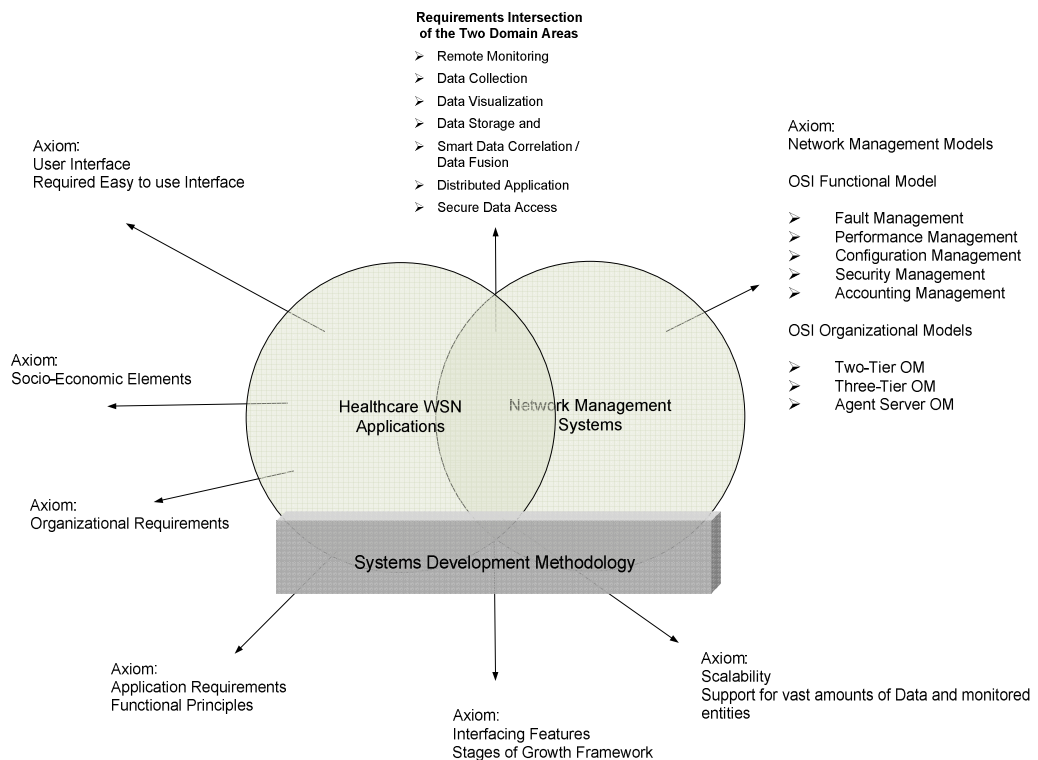

Figure 9.1 MoteCare Project – Stage I

Important elements were encountered in this crucial stage such as the mapping of a healthcare WSN application requirements to the potential alternative solutions which network management systems had to offer. The intersecting requirement commonalities across areas were identified (see Figure 9.1). The explained similarities in functionality and structure of the NM OSI Functional and Organizational models respectively were crucial features identified at this stage. Furthermore their flexibility and modularity allowed the researcher to adapt and ground the development of the MoteCare system.

The Systems Development Methodology (SDM) aided the finding of general and specific requirements of the MoteCare system. The device interfacing requirements were given special attention as per the mobile nature and healthcare specific requirements. The SDM as well as the Stages of Growth Framework [Stages of Growth Framework (Ooi et al (2005))] were utilized in the interfacing device selection.

The second stage includes the final phases of the system development methodology with the development and system design implementation of the NM based system architecture and the applying of the rapid prototyping methodology in conjunction with the Modification and Extension model (Kranz, 2006) to the building of MoteCare system and its progressive series of enhanced systems, namely MoteCare, Mobile MoteCare, Stargate MoteCare and Medical MoteCare systems.

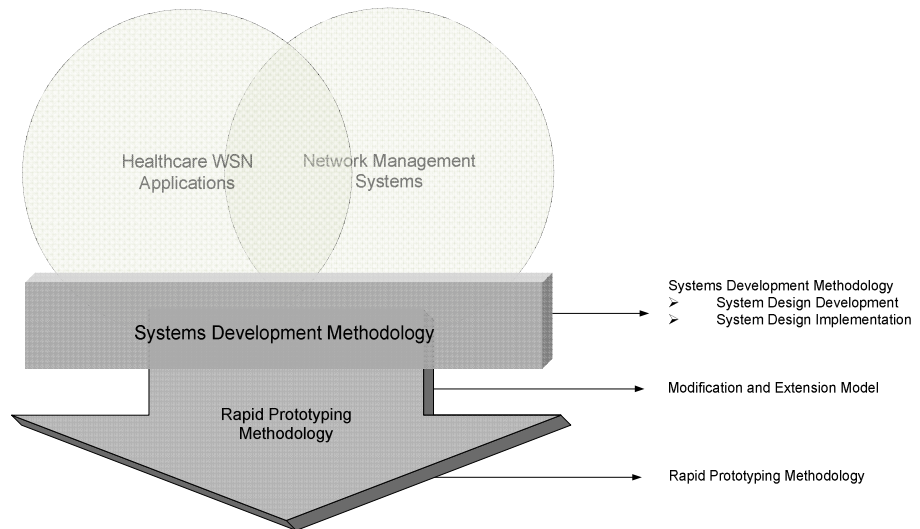

Figure 9.2 MoteCare Project – Stage II

### 9.3 Discussion of Stage I

As per the multidisciplinary nature of this project and the embryonic state of research into WSN based Personal Health Care systems, the literature review themes were broken up into subcategories according to the relevance and necessities of the project.

The WSN based Personal Health Care Applications investigation (left sphere domain represented in Figure 9.2) first introduces a general and informative context with statistical data of the present and future needs of more effective and affordable remote health services in the national health care systems of the developed world economies

followed by the examination and evaluation of the current situation of personal mobile health systems and applications.

The following sections in Stage One are of a more technical nature. The first one investigates Wireless Sensor Network technologies and researches the robust points and weaknesses of the technology at this time, whereas the second one looks into standardized Network Management models and techniques (right sphere domain in Figure 9.2) and analyses their relevance and adaptability to Personal Health Monitoring systems. The baseline between the two domains that aided this purpose was obtained by applying the systems development methodology with the identification of the main functional requirements of a personal health monitoring system.

This work commenced in February 2004 and has resulted in the development of four systems, each one building incrementally on the next and outlined in a series of papers (one of which obtained a Best Paper award) presented in the publication list section at the beginning of this document.

The Systems methodology is outlined in Table 9.1 below (Felix Navarro et al, 2006).

*Table 9.1 Systems Development Methodology  
(Felix Navarro et al, 2006)*

<b>MoteCare Systems Development</b>
Identification of the requirements for the proposed WSN healthcare monitoring application and network management systems.
Identification of possible solutions by analysing and comparing major problems in both technologies.
Adaptation of proven Network Management models & techniques for problem resolution.

Strategic design development to implement these solutions.

Proof of concept – development of working prototype systems.

Evaluation and improvement (Action Research) – evaluate the developed tool for healthcare monitoring arena.

## 9.4 Discussion of Stage II

The second stage includes the last phases of the systems development methodology that includes the design and implementation in combination with the rapid prototyping method to the building of the MoteCare system architecture and its progressive series of enhanced systems. The developed system architectures include the functional and communication flow system diagrams and the high level system and communication design architectures. The system development methodology is also applied for the interfacing analysis and device selection.

The implementation of the proposed system architecture for the evolving systems required important developments in the middleware layer to match and communicate efficiently with the WSN Layer and the NM Core Layer. The respective systems are also tested for basic functionality and further improvement in this final stage.

## 9.5 The Layered MoteCare System

The produced working systems are comprised of a three layered structure; the WSN Layer, the Middleware Layer and the Core Layer. The layered architecture presented in Figure 9.3 was developed with the purpose of obtaining a better understanding of the system, but furthermore, it was formulated to aid, with its modularity, the further

research and development of future NM based WSN application technologies.

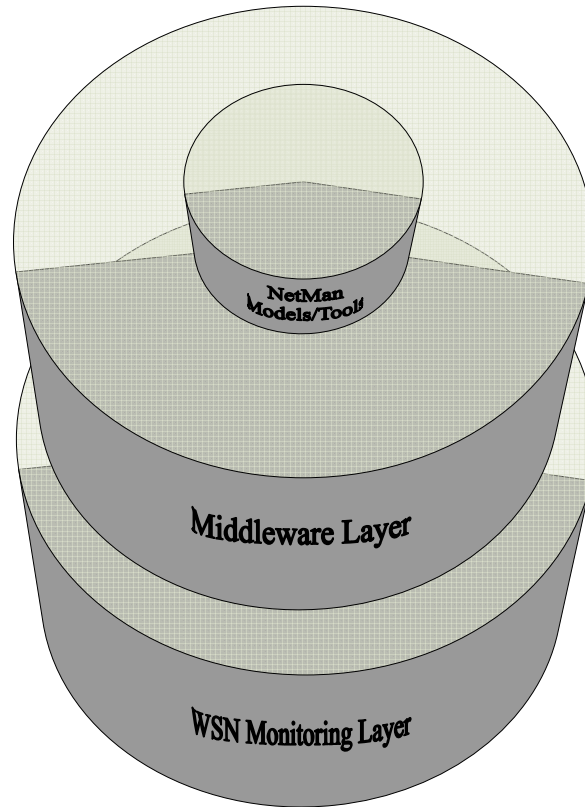

*Figure 9.3 The Layered MoteCare System*

Table 9.4 presents a summary of the main elements on each layer in the building of the MoteCare project. A subsequent detailed explanation of these layered components is further presented after Table 9.4.



Table 9.2 The Main MoteCare Development Components Per Layer

Core Layer	Middleware Layer	WSN Layer
<b>NM Models</b>		
OSI Organizational Model	Proxy Agent – Perl	Motes
OSI Functional Model	SNMP Proxy	Mote Processor Board
<b>NM Protocols</b>	Log Filing Script	Stargate Personal
SNMP	MoteCare MIB	Server
<b>NM Tools</b>	Smart Phone Interface	RF Communication
MRTG	RF, WiFi, GSM protocols	Technologies
iReasoning MIB Browser		
SysUpTime Network		
Monitor		
Jaguar XS		

### 9.5.1 The WSN Layer

The WSN Layer is the foundation layer that corresponds to the hardware sensors for the collection of the data and the devices and communication technologies among them to, either bidirectional or unidirectional, transfer the information from the WSN to an IP enabled networked system. The main hardware elements in the WSN layer are the Motes, the Mote Base Station or Mote Processor Board, the Stargate Personal Server, and the various communication technologies used by the motes or gateway devices such as the Stargate Personal Server and or the Mote Processor Board.

There are important aspects on the WSN Layer that should be taken into account:

- frequency and nature of the monitoring data;
- user interfacing;
- allowance for bidirectional communication whenever possible with the middle and core layers;

- placement survey –system analysis and testing to ensure correct hardware emplacement for efficient communication flow among devices.

### **9.5.2 The Middleware Layer**

The Middleware Layer consists of developed software to assemble and communicate the between WSN Layer and the NM Core Layer. The Middleware layer also comprises the developed user interface of the system whenever additional interfacing features are required for the particular application.

The Middleware layer provides transparency to the applications/ services that utilize these sensor networks, so the requirement of adhering to just one brand of sensor devices is removed. This concept of providing a middleware layer is not unique to sensor networks. Research and development work has been done with other heterogeneous networks on middleware development. In the context of the MoteCare layered prototype, the middleware layer is a required channel of communication between the WSN layer and the NM Core Layer. Refer to Table 9.4 for a summary of the middleware layer components implemented in the MoteCare systems.

### **9.5.3 The NM Core Layer: Network Management Models and Techniques**

The NM Core layer corresponds to the NM models, tools and techniques. This cylindrical shaped core layer contains the main functionality of the system and transverses the other two layers of the schema. The primary elements of the implemented NM Core Layer are presented in Table 9.4.

## 9.6 The Heterogeneous Framework

Below in Figure 9.4 is a graphical representation of the heterogeneous NM-WSN Application Development Framework as developed by the author. The presented holistic framework is conformed by the grouped entities playing a major role on each of the MoteCare project phases explained in previous sections. This framework could be adapted for use in the development of other WSN healthcare applications in the future as the technology improves.

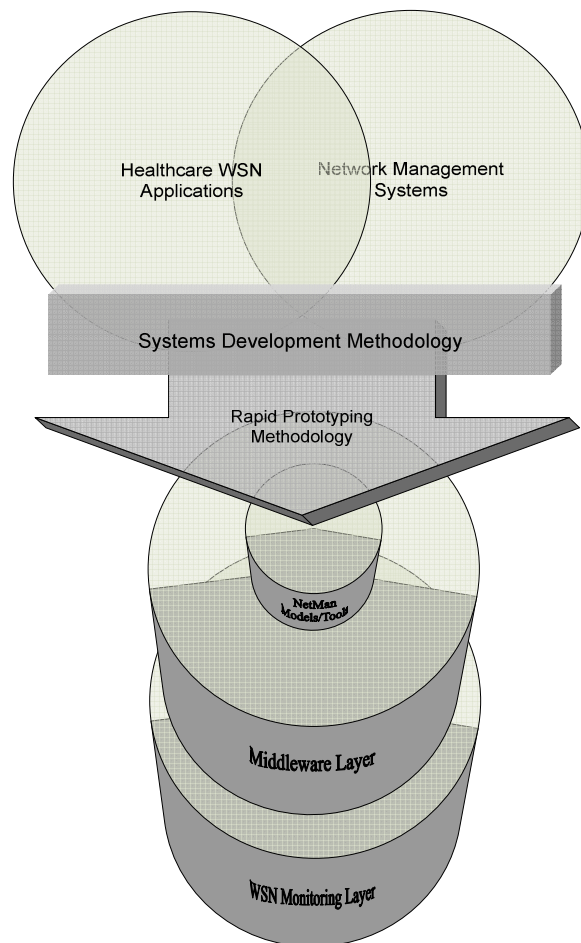

Figure 9.4 The NM-WSN Application Development Framework

## 9.7 Analysis and Recommendations

The following analysis and recommendations presented in this section follow the structure of the Layered MoteCare System previously explained and described in Section 9.5. It presents the overall observations in the development of the system and describes the pitfalls of the various technologies on each layer when building the MoteCare system. Recommendations are given at the end of each module. This document will conclude with a briefing of the evaluated hypotheses outcomes, followed by the conclusions and future directions of research.

### 9.7.1 Core Layer: Network Management Models and Techniques

As explained earlier in this chapter, the core layer comprises the network management models and techniques that assisted in the development of the MoteCare project. NM models such as the OSI Organizational and OSI Functional models were core in the building of the MoteCare systems. The NM intersecting features and the four OSI Functional model domains presented in Table 9.4 are, whenever present, built into the modularity and features of the various network management tools utilized in the MoteCare project. In the case of the OSI Organizational models some characteristics of the adapted models had to be tailored in accordance to each of the evolving systems as explained in Chapters 6, 7 and 8 respectively.

In the previous section, a summary of the Core Layer elements is shown in the third column of Table 9.4. These Core Layer elements represent the essential constituent of the various systems built as part of the MoteCare project. Table 9.5 presents a categorized dissection of such main elements reflecting concrete features or alignments on each of the four MoteCare systems.

Table 9.3 Core Layer Element Dissection per MoteCare System

	<b>MoteCare</b>	<b>Mobile MoteCare</b>	<b>Stargate MoteCare</b>	<b>Medical MoteCare</b>
<b>NM Intersecting Features</b>				
Remote Monitoring	X	X	X	X
Data Collection	X	X	X	X
Data Visualization	X	X	X	X
Data Storage	X	X	X	X
Alarm Triggering			X	X
Smart Data Correlation				X
<b>NM Additional Features</b>				
Distributed Relational DB			X	X
Web Enabled Interface	X	X	X	X
<b>OSI Functional Model Features</b>				
Fault Management		X	X	X
Performance Management	X	X	X	X
Security Management		X	X	X
Accounting Management				*
<b>OSI Organizational Models</b>				
Proxy Server	X	X	X	X
Two-Tier	X	X		
Three-Tier			X	X
<b>NM Tools</b>				
MRTG	X	X	X	
iReasoning MIB Browser				X
SysUpTime Network Monitor				X
Jaguar SX				X
<b>NM Communication Protocols</b>				
SNMP				X

*\*Accounting Management is supported by the Medical MoteCare system however it was not implemented as it was outside the scope of this research project.*

### 9.7.2 Core Layer Recommendations

The researcher makes the following suggestions:

- real time healthcare application requirements;
- lack of WSN protocol standards to develop WSN Applications;
- open Source NM tools lacking of the required complexity for data fusion / had to use proprietary software;
- difficult finding of easy-to-use Open Source NM tools.

### 9.7.3 Middleware Layer

As previously explained in Section 9.5, the Middleware Layer can be contextualized as the “glue” between the Core and the WSN layer as well as the layer responsible of assuring an end-to-end delivery of service to the user. This definition can better reflect the potential heterogeneity of this layer and hence can explain the occasional difficulty in defining its boundaries between these other two layers. It is comprised of a number of diverse elements ranging from a close proximity to the Core Layer (such as the tailored SNMP Proxy Agent) to the various wireless protocols to communicate the Core and WSN layers.

The middle layer developments in the MoteCare project aimed to satisfy the scope of this thesis, which, in the majority of the presented built systems, was to enable generic main functional communication requirements between the Core and WSN layers for the central operation of a remote personal healthcare monitoring application. Apart from a few of the additional usability, security, delivery of service features that are presented in Table 9.6 below, the researcher presents recommendations for further development in this layer.

Table 9.4 MoteCare Middleware layer Recommendations

<b>MoteCare Middleware layer Recommendations</b>
▪ Error Check Delivery of Service Layer Supervision
▪ Personalised Interfacing – Doctor / Nurses / Home Users
▪ Additional Security Features outside the Core and WSN Layers scope
▪ Smart Buffering Techniques whenever required
▪ Quality of Service Implementation

#### 9.7.4 WSN Layer

The WSN Layer components, even though they provide advantages to the health monitoring domain, such as low cost hardware, mobility and long term powered connectivity (sleep mode), still have many limitations that need to be resolved in the hardware side in order to make these devices efficient, robust and easy to use off-the-shelf components for users and developers alike. Some of these limitations and recommendations are presented below.

Table 9.5 Limitations and Recommendations for the WSN Layer

<b>Limitations</b>	<b>Recommendations</b>
▪ Lack of WSN standardised communication protocols for the development of WSN applications	▪ The development of a flexible standard WSN communication protocols for data application developments
▪ Not a large variety of generic mote-sensors in the market ▪ Lack of medical sensors	▪ Availability of generic and medical sensors ▪ Plug-and-Play off the shelf mote-sensors

<ul style="list-style-type: none"> <li>▪ Difficult to troubleshoot</li> <li>▪ Faulty hardware</li> </ul>	<ul style="list-style-type: none"> <li>▪ Easy identification of the motes</li> <li>▪ Robustness</li> </ul>
<ul style="list-style-type: none"> <li>▪ Difficult User Interface</li> </ul>	<ul style="list-style-type: none"> <li>▪ Easy developers/user interfacing</li> </ul>

## 9.8 Hypotheses Testability Outcomes

The summarized Core Layer Element Dissection per MoteCare System presented in Table 9.5 served the researcher to account for testability purposes of the formulated hypotheses of this project presented in Chapter One of this document. The three original evaluated hypotheses with their corresponding resulting outcomes are presented below.

### Hypothesis 1

**H.1** *"That network management techniques can be used to assist in the development of a distributed Personal Healthcare Monitoring System and lead to the development of a generic network management framework for healthcare applications."*

The outcomes presented and explained in this thesis led to prove Hypothesis One as **"True"** as the researcher facilitated the development of a distributed personal healthcare monitoring system by applying network management techniques of diverse nature, namely NM tools and standardised NM models and protocols to the building of a personal healthcare monitoring system (see Table 9.5 for specific details of the applied NM techniques on each of the built MoteCare systems); and that this work led to the development of a generic NM framework for healthcare applications (see Figure 9.4).



## Hypothesis 2

**H.2** *"That such a personal healthcare monitoring system could replace medical monitoring proprietary based systems with less expensive commodity based hardware and open source software."*

The testability outcomes of Hypothesis Two led to a **"Conditional True"**. This "True" is conditional to the specific hardware and software complexity requirements of the medical monitoring system, namely the availability of open source network management software and medical sensors and for the specific health monitoring requirements of the patient. Despite the fact that a personal healthcare monitoring system was developed and tested with less expensive commodity based hardware and open source NM software (see Table 9.5 for details), the existing deficiency of standardised medical sensors for WSN platforms and flexible open source network management tools of a higher complexity led the researcher to this conclusion. Further advancements in the WSN technologies and open source network management developments can potentially bring this to a more ample tangible reality.

## Hypothesis 3

**H.3.** *That a network management tool can add intelligence to a health monitoring system by measuring and correlating a number of signals and alerting when certain conditions represent specific undesirable events, or a threat for the patient.*

Hypothesis Three was proved as **"True"**, as smart correlation techniques and alarm triggering of two network management tools, namely SysUpTime Network Monitor and Jaguar SX, were used to add intelligence and responsiveness to the developed personal healthcare monitoring system Medical MoteCare. Multiple variable correlation of medical data was implemented and test it as well as the triggering of

an alarm when a single or a combination of specific previously set variable conditions were detected (see Table 9.5 for details). However it must be noted that open source software was not sufficiently robust for this task.

## 9.9 Conclusions and Future Research Directions

The evolving developed systems as part of the MoteCare project demonstrate that the design and functionality of WSN personal healthcare monitoring systems can be aided by the adaptation of well known network management models, tools and communication protocols. For instance as applied in this thesis, but not limited to, the NM OSI Organizational and NM OSI Functional models aided the design and functional modularity respectively, whereas the use of NM protocols, distributed NM tools of diverse complexity incorporated some of the inbuilt generic personal health monitoring functionality and enhanced features.

The replacement of medical monitoring proprietary based systems with less expensive commodity based hardware and open source software can be achieved to a certain degree. However, there are still degrees of software and hardware limitations to be resolved such as the availability of flexible easy-to-use open source NM software, the robustness of the WSN hardware devices, the lack of WSN communication standards and medical sensors and mote-wearability issues among others. However, open source NM techniques in conjunction with the use of off-the-shelf commodity hardware such as motes and other WSN devices, smart phones and laptops can provide an alternative channel for the development of affordable remote personal healthcare monitoring systems.

Future directions from this research point towards new areas of knowledge from the development or creation of new technologies to support the exponential growth of ubiquitous, just-in-time WSN health informational services and applications such as the preventive and proactive personal care health management and services around it. The affordable and ubiquitous distributed access to remote personal health care technologies in the future could have an important impact in the society, by allowing the individuals to take immediate preventive actions over their overall health condition. These systems could potentially prevent death as well as improve national health budgets by limiting costly medical interventions that could have been avoided by individual, easy-action early prevention.

In addition to this, the dispersion of potential benefits of these new technologies are not exclusive to the advancement of information technologies, health or social sciences, but also to all other areas of knowledge where the ubiquitous distributed access to personal and or environmental remote information in real time can enhance the quality of living of human kind.

# References

- Abowd, G.D. and Sterbenz, J.P.G. (2000) Final report on the inter-agency workshop on research issues for smart environments. IEEE Personal Communications, October 2000, vol.7, no.5, pp.36-40.
- AIHW (2002) National Mortality Register. Statistics for Heart Failure in the Australian population. From: <http://www.aihw.gov.au/>
- AIHW (2006) Dementia in Australia: National data analysis and development. Australian Institute of Health and Welfare (AIHW). From: <http://www.aihw.gov.au/publications/age/dandad/dandad.pdf>.
- Akihisa Kodate (2003) Mobile Health Global Information and Telecommunication. Institute in Waseda University in Japan, From: <http://www.itu.int/osg/spu/ni/futuremobile/presentations/kodate-presentation.pdf>.
- Akyildiz, I. F., Su, W., Sankarasubramaniam, Y. and Cayirci, E. (2002) Wireless sensor networks: A survey. Journal Computer Networks, Vol. 38(4), pp. 393-422.
- Anon (2008) A Brief Guide to OIDs, From: [middleware.internet2.edu/a-brief-guide-to-OIDs.doc](http://middleware.internet2.edu/a-brief-guide-to-OIDs.doc)
- Arampatzis, T., Lygeros, J. and Manesis, S. (2005) A Survey of Applications of Wireless Sensors and Wireless Sensor Networks. Paper presented at the Intelligent Control. Proceedings of the 2005 IEEE International Symposium on, Mediterrean Conference on Control and Automation.
- Australian Bureau of Statistics (1999) Housing Assistance: Home care, hostels & nursing homes. Australian Bureau of Statistics Australian Social Trends. From: <http://www.abs.gov.au>.
- Australian Bureau of Statistics (2002) From: <http://144.53.252.30/ausstats/abs@.nsf/web+pages/statistics?open+document>.

- Australian Bureau of Statistics (2007) 3201.0, Population by Age and Sex, Australian States and Territories, June 2007, From: <http://www.abs.gov.au/>.
- Australian Social Trends (2005) Australian Social Trends, Vol. Previous ISSUE Released at 11:30 AM (CANBERRA TIME) 12/07/2005.
- Avancha, S., Undercoffer, J., Joshi, A. and Pinkston, J. (2006) Security for Wireless Sensor Networks. In Raghavendra et al (Ed.), Wireless Sensor Networks 253-275: Springer.
- Babiloni, F., Carducci, F., Cerutti, S., Liberati, D., Rossini, P., Urbano, A. and Babiloni, C. (2000) Comput Biomed Res, pp. 59-74.
- Berkley (2006) From: [http://www-bsac.eecs.berkeley.edu/researchHighlights/pdf/PressRelNSF\\_AssocB\\_SAC\\_Web.pdf](http://www-bsac.eecs.berkeley.edu/researchHighlights/pdf/PressRelNSF_AssocB_SAC_Web.pdf).
- Black, M. (2006) Biologically Embedded Computing. From: <http://www.cs.brown.edu/people/black/>.
- Bonnet, P., Gehrke, J. and Seshadri, P. (2000) Querying the physical world. IEEE Personal Communications, October 2000, vol.7, no.5, pp. 10-15.
- Bowen C. (2006) THE AMERICAS: US oncologists to debate cancer care costs. The Financial Times, pp. 8.
- Branhamgroup (2006). From: [http://www.branhamgroup.com/media/articles/Vol\\_XIX\\_No\\_4\\_4.pdf](http://www.branhamgroup.com/media/articles/Vol_XIX_No_4_4.pdf)
- Bulusu N., Estrin. D., Girod L. and Heidemann J. (2001) Scalable coordination for wireless sensor networks: self-configuring localization systems. In Proceedings of the 6th IEEE International Symposium on Communication Theory and Application (ISCTA 2001), July 2001, Ambleside, UK.
- Castaneda, D., Mac Alasdair, O. and Vinckier, C. (2006) The Business Case for Enterprise-Class Wireless Lans. Indiana: Cisco Press.
- Catalano, J. T. (2002) Nursing Now: Today's Issues, Tomorrow's Trends. 3<sup>rd</sup> Edition, F a Davis Co.
- CDC (2005) Falls and Hip Fractures among Older Adults. CDC. From: <http://www.cdc.gov/ncipc/factsheets/falls.htm>.
- Celler, B.G., Hesketh, T., Earnshaw, W. and Ilsar, E. (1994) An instrumentation system for the remote monitoring of changes in functional health status of the elderly at home. IEEE-EMBS. 1994. Engineering Advances: New Opportunities for Biomedical Engineers.

Proceedings of the 16th Annual International Conference of the IEEE, pp. 908-909 vol.2.

Cerpa, A., Elson, J., Estrin, D., Girod, L., Hamilton, M., and Zhao, J. (2001) Habitat monitoring: application driver for wireless communications technology. SIGCOMM Comput. Commun. Rev. 31, 2 supplement (Apr. 2001), 20-41.

Chandrakasan A., Amirtharajah. R., Cho S., Goodman J., Konduri G., Kulik J., Rabiner W. and Wang A. (1999) Design considerations for distributed micro-sensor systems. In Proceedings of the IEEE 1999 Custom Integrated Circuits Conference (CICC '99) (May 1999), pp. 279--286.

Chu, M., Reich, J. and Zhao, F. (2004). Distributed attention in large scale video sensor networks. Intelligent Distributed Surveillance Systems, IEE , vol., no., pp. 61-65.

Cisco (2007) From: [http://www.cisco.com/univercd/cc/td/doc/cisintwk/ito\\_doc/nmbasics.htm](http://www.cisco.com/univercd/cc/td/doc/cisintwk/ito_doc/nmbasics.htm).

Cisco (2006) From: [http://www.cisco.com/univercd/cc/td/doc/cisintwk/ito\\_doc/nmbasics.htm#xtocid3](http://www.cisco.com/univercd/cc/td/doc/cisintwk/ito_doc/nmbasics.htm#xtocid3).

CMOS (2006) From: <http://en.wikipedia.org/wiki/Cmos>.

Coach's Companion (2003) From: <http://limlloyd.com/coach/coach-below.html>.

Cochrane (2005 ) The Cochrane Collaboration. From: <http://www.cochrane.org/>.

Collins, S. (2004) Huge market for wireless monitor. The New Zealand Herald (Health & fitness). From: [www.nzherald.co.nz/storydisplay.cfm?thesection=news&thesubsection=&storyID=3553838&reportID=16](http://www.nzherald.co.nz/storydisplay.cfm?thesection=news&thesubsection=&storyID=3553838&reportID=16).

Commodity Computer. From: [http://en.wikipedia.org/wiki/Commodity\\_computer](http://en.wikipedia.org/wiki/Commodity_computer).

Compaq. From: <http://www.compaq.com>.

Connor, W., Krishnamurthy, L. and Want, R. (2001) Making Everyday Life Easier Using Dense Sensor Networks. Ubicomp, pp. 49 - 55.

Coyle G., Boydell L., Brown L. (1995) Home telecare for the elderly. Journal of Telemedicine and Telecare, Vol. 1, pp. 183-184.

Crossbow Technology Inc. (2005). From: <http://www.xbow.com/>.

Crossbow (2006). From: <http://www.xbow.com>.

- Culler, D., and Hong W. (2004). Wireless Sensor Networks - Introduction. Communications of the ACM, vol. 47, no. 6, pp. 30-33.
- Diabetes Pilot (2006) From: <http://www.diabetespilot.com>.
- Digital Plaster Project (2007) From: <http://www.toumaz.com/products/sensium.htm>.
- Dipert, B. (2004) The Human Touch keeps the Elderly and Disabled Technology connected. EDN, pp. 47-57. From: [www.edn.com](http://www.edn.com).
- Dishman, E. (2004) Inventing Wellness Systems for Aging in Place. IEEE Computer, Vol. 37(No.5), pp. 34-41.
- Comer, D. E. (2000) Internetworking with Tcp/Ip, Volume 1: Principles, Protocols, and Architectures, Fourth Edition. 4th. Prentice Hall PTR.
- Douglas E. Mauro and Kevin J. Schmidt. (2005) Essential SNMP. O'Reilly, Sebastopol, 2005.
- Elson, J. and Estrin, D. (2006) Sensor Networks: A Bridge to the Physical world, Wireless Sensor Networks, Ravhavendra, CS et al, 2006 Springer.
- Essa, I. A. (2000) Ubiquitous sensing for smart and aware environments. IEEE Personal Communications, October 2000, vol.7, no.5, pp. 47-49.
- Felix Navarro, K., Lawrence, E. and Lubrin, E. (2006) A Network Management Approach To Wireless Sensor Networks In Personal Healthcare Environments, The Fifth IASTED International Conference on Communication Systems and Networks ~CSN 2006~ Palma de Mallorca, Spain August 28 – 30, 2006.
- Fiedler, M. NM Basic Foundations: Standards, Models, and Language. From: <http://www.its.bth.se/courses/tnm204/tnm20403.pdf>.
- Fischer, M. (2008) Enhancing the ReMoteCare prototype by adding an SNMP proxy and video surveillance. University of Technology Sydney.
- Fischer, M., Lim, Y.Y., Lawrence, E., Leena K. Ganguli and Karg, F. (2008) ReMoteCare: Health Monitoring with Streaming Video, IEEE International Conference on mBusiness, Barcelona, July 9-11, 2008
- Geer, D. (2005) Users make a Beeline for ZigBee sensor technology Computer, Vol. 38(12), pp. 19.
- Georgeff, M. (2007) Director of e-Health Research, Monash Institute of Health Services Research

- Gibson, C.F. and Nolan R.L. (1974) Managing the Four Stages of EDP Growth. *Harvard Business Review*, vol. 52, no. 1, pp. 76-88.
- Gosbee, J. and Ritchie, E. (1997) Human-computer interaction and medical software development. *interactions*, 4(4):13-18, 1997.
- Group, P.D. (2002) PostgreSQL 7.3. Documentation
- Gururajan R., Murugesan S. and Soar J. (2005). Introducing Mobile Technologies in Support of healthcare. *Cutter IT Journal: The Journal of Information Technology Management*, pp. 12-18.
- Hameed, K. (2003) The application of mobile computing and technology to health care services. *Telematics and Informatics*, vol. 20, no. 2, pp. 99-106.
- Hassan, G., Douglas B.H. Scott. (1981) Prototyping as a tool in the specification of user requirements. In *ICSE '81: Proceedings of the 5th international conference on Software engineering*, pages 333-342, Piscataway, NJ, USA, 1981. IEEE Press. GS81.
- He, T., Krishnamurthy, S., Stankovic, J. A., Abdelzaher, T., Luo, L., Stoleru, R., Yan, T., Gu, L., Hui, J. and Krogh, B. (2004) Energy-efficient surveillance system using wireless sensor networks. In *Proceedings of the 2nd international Conference on Mobile Systems, Applications, and Services*, Boston, MA, USA, June 06 - 09, 2004.
- Healthservice24. (2007). From: [http://www.healthservice24.com/healthservice24/images//HS24\\_Project%20Presentation.pdf](http://www.healthservice24.com/healthservice24/images//HS24_Project%20Presentation.pdf).
- Herring, C. and Kaplan, S. (October 2000) Component-based software systems for smart environments. *IEEE Personal Communications*, vol.7, no.5, pp.60-61.
- Istepanian, R.S.H. and Lical, J.C. (2003) Emerging mobile communication technologies for health: some imperative notes on m-health. *IEEE Engineering in Medicine and Biology Society (EMBC), Proceedings of the 25th Annual International Conference of the IEEE*, vol.2, no., pp. 1414-1416.
- ISO 2007. From: [http://www.iso.org/iso/about/discover-iso\\_the-scope-of-isos-work.htm](http://www.iso.org/iso/about/discover-iso_the-scope-of-isos-work.htm).
- ITU/MIC 4-5 March 2004, Workshop on "Shaping the Future Mobile Information Society". Seoul.
- Java Technology (2005). From: <http://java.sun.com>.



- Johnson D. and Johnson M. (2003) The Impact of Wireless Technology on the Health Care Industry, May 2003, Information System in Organizations.
- Johnson D. and J. M. (2003) The Impact of Wireless Technology on the Health Care Industry. Information System in Organizations.
- Johnson, P. and Andrews D.C. (1996) Remote continuous physiological monitoring in the home. J Telemed Telecare, pp. 107-113.
- Kahn, J. M., Katz, R. H., and Pister, K. S. (1999) Next century challenges: mobile networking for "Smart Dust". In Proceedings of the 5th Annual ACM/IEEE international Conference on Mobile Computing and Networking. MobiCom '99. pp. 271-278.
- Kintner-Meyer M. and Brambley M. R. (Nov 2002). Pros & Cons of Wireless. ASHRAE Journal, vol. 44, no. 11, pp. 54-61.
- Klerer, S.M. (1988) The OSI management architecture: an overview, Network, IEEE 2 (2):20-29, 1988.
- Konstantas, D. (2004) The Mobihealth Project. IST Project. European Commission: Deliverable 2.6 IST-2001-36006. From: <http://www.mobihealth.org>.
- Koubaa, A., Alves, M and Tovar, E. (2005). Lower Protocol Layers for Wirelss Sensor Networks: A Survey, Technical report. IPP Hurray. From: [www.hurray.isep.ipp.pt](http://www.hurray.isep.ipp.pt).
- Kranz, M. and Schmidt, A. (2006) Restriction, Modification and Extension of Consumer Devices for Prototyping Ubiquitous Computing Environments. ICDCSW '06: Proceedings of the 26th IEEE International Conference Workshops on Distributed Computing Systems. Washington, DC, USA, IEEE Computer Society, pp. 57.
- Kurzweil, R. (2005) Human 2.0. New Scientist, pp. 32 -37.
- Lawrence, E., Felix Navarro, K., Riudavets, J. and Messina, M. (2004) Macroscopic Sensor Networks: Application Issues in the Healthcare Industry. Third International ISCA Conference on Computer Science, Software Engineering, Information Technology and eBusiness and Applications (CSITeA 2004).
- Leijdekker, P., Gay, V. and Lawrence, E. (2007) Smart Homecare System for Health Tele-monitoring. IEEE Proceedings International Conference on Digital Society.
- Lewis, W. (2005) CCNP4: Network Troubleshooting Companion Guide. Indiana: Cisco press.

- Lewis, F. L. (2004) *Wireless Sensor Networks, Smart Environments: Technologies, Protocols, and Applications*, ed. D.J. Cook and S.K. Das, John Wiley, New York, 2004.
- Dan Li, Wong, K.D., Yu Hen Hu and Sayeed, A.M. (Mar 2002) Detection, classification, and tracking of targets. *IEEE Signal Processing Mag.*, vol.19, no.2, pp.17-29.
- Lim, L. and Yee, B. *Coach's Companion - Athlete's Health Monitoring System*. University of California, Berkeley, From: <http://www.limlloyd.com/coach/>.
- Lubrin, E. Lawrence, E and Felix Navarro, K. (2005) *Wireless remote healthcare Monitoring with Motes*, fourth International Conference on Mobile Business, July 11- 13, Sydney, Australia.
- Lubrin, E., Lawrence, E. and Felix Navarro, K. (2006) *Motecare: An Adaptive Smart Ban Health Monitoring System*, The Fourth IASTED International Conference on Biomedical Engineering, Biomed 2006~February 15- 17, 2006, Innsbruck, Austria.
- Lubrin, E., Lawrence, E. & Navarro, K.F. (2006) *MoteCare: an adaptive smart BAN health monitoring system*. *BioMed'06: Proceedings of the 2fourth IASTED international conference on Biomedical engineering*. Anaheim, CA, USA, ACTA Press, pp. 60.
- Lubrin, E., Lawrence,E, Felix Navarro, K. (2006) *An Architecture for Wearable, Wireless, Smart Biosensors: The MoteCare Prototype* IEEE Proceedings of Mobile Computing and Learning Conference (MCL 2006) Mauritius April 24 - 28, 2006. \* Best Paper Award\*
- M. Subramanian, (2000) *Network Management: Principles and Practice*, Addison Wesley, USA.
- Mache, J., Allick, C., Charnas, J., Hickman, A., Tyman, D. (2006) *Sensor Network Lab Exercises Using TinyOS and MicaZ Motes* Mathematical and Computer Science Lewis & Clark College Portland OR, USA. [jmache@lclark.edu](mailto:jmache@lclark.edu). From: <http://ww1.ucmss.com/books/LFS/CSREA2006/PSC7270.pdf>.
- Maisel, A. S., Padma Krishnaswamy, Richard M. Nowak (2002) Rapid measurement of B-Type natriuretic peptide in the emergency diagnosis of heart failure. *N Engl J Med*, Vol. 347, pp. 161-167.
- Malan D., Fulford-Jones T., Welsh M. and Moulton S. (2004) *CodeBlue: An Ad Hoc Sensor Network Infrastructure for Emergency Medical Care*. In *Proceedings of the WAMES Workshop on Applications of Mobile Embedded Systems. International Workshop on Wearable and Implantable Body Sensor Networks*, London, April 2004.

- Mallat, N. (2007) Theoretical Constructs of Mobile Payment Adoption. IRIS2007, Sweden.
- Mann, S. (1998) International Conference on Wearable Computing ICWC-98. Fairfax VA.
- Market Analysis (May 2004). Financial challenges stress hospital-physician relationships.
- Martin, T., Jovanov, E. and Raskovic, D. (2000) Issues in Wearable Computing for Medical Monitoring Applications: A Case Study of a Wearable ECG Monitoring Device. ISWC '00: Proceedings of the fourth IEEE International Symposium on Wearable Computers. Washington, DC, USA, IEEE Computer Society, pp. 43.
- Mauro, D., and Schmidt, K. (2001). Essential SNMP: 326: O'Reilly.
- McMurray, J. J. V., and Stewart, S. (2002) The burden of heart failure. European Heart Journal Supplements, pp. D50-D58. From: [http://eurheartjsupp.oxfordjournals.org/cgi/reprint/4/suppl\\_D/D50.pdf](http://eurheartjsupp.oxfordjournals.org/cgi/reprint/4/suppl_D/D50.pdf)
- Medicalnewstoday. (2004). Health Care Expenditures in the USA. Statistics National Center for Health. From: <http://www.medicalnewstoday.com/index.php?newsid=6225>.
- Medicinenet (2007) From: [http://www.medicinenet.com/wolff-parkinson-white\\_syndrome/article.htm](http://www.medicinenet.com/wolff-parkinson-white_syndrome/article.htm)
- Meesookho, C., Narayanan, S. and Raghavendra, C.S. (2002). Collaborative classification applications in sensor networks. Sensor Array and Multichannel Signal Processing Workshop Proceedings, 2002 , pp. 370-374.
- Messina, M. (2004) 3MoS: Mobile Health Monitoring by Motes System. From: <http://www-staff.it.uts.edu.au/~messina>.
- Messina, M. (2004) 3MoS: A ubiquitous solution in m-health prevention, diagnosis and monitoring. Device-independent services and data collection. From: <http://www-staff.it.uts.edu.au/~messina/>.
- Messina, M., Lawrence, E., Felix Navarro, K. and Lubrin, E. (2007) Towards Assistive Healthcare: Prototyping Advances In Wireless Sensor Network (Wsn) Systems Integration And Applications, IADIS International Conference e-Society 2007Lisbon, Portugal 3-6 July 2007
- Messina, M., Lim, Y. Y., Lawrence, E. , Martin, D. and Kargl, F. (2008) Implementing and Validating an Environmental and Health

- Monitoring System, IEEE ITNG Conference, Las Vegas, 7-9 April, 2008.
- Microsoft Developer Network 2005. From: <http://www.msdn.com>.
- Mizrachi, D. (2000) Info-fashions for the new millennium. Medford, vol. 24, no. 1, p. 82.
- Mobihealth (2003) From: <http://www.mobihealth.org/>.
- Monthly Labor Review (2004) Monthly Labor Review. U.S. Bureau of Labor Statistics. From: [www.bls.gov/news.release/ecopro.toc.htm](http://www.bls.gov/news.release/ecopro.toc.htm).
- Moody, D., and Busit, A. (1999) Proceedings of the 10th Australasian Conference on Information Systems, Vol. 2: 645 -659.
- Motes. (2005). From: <http://robotics.eecs.berkeley.edu/~pister/SmartDust/>.
- MPR400/410/420. From: [http://www.xbow.com/Support/Support\\_pdf\\_files/MPR-MIB\\_Series\\_Users\\_Manual.pdf](http://www.xbow.com/Support/Support_pdf_files/MPR-MIB_Series_Users_Manual.pdf).
- MRTG (2007) Retrieved 19 April, 2006. From: <http://oss.oetiker.ch/mrtg/>.
- MySQL. (2007). Retrieved 20 January, 2007. From: <http://www.mysql.com/>.
- Navarro, K.F., Lawrence, E. and Lubrin, E. (2006) A Network Management Approach to Wireless Sensor Networks in Personal Healthcare Environments. Communication Systems and Networks, p. 543.
- NEJM (2004) The New England Journal of Medicine From: <http://www.mynpi.org/Content/SP/ADTMain.htm>.
- NEST team (2003) The Ohio State University. From: [http://www.cse.ohiostate.edu/siefast/nest/nest\\_webpage/ALineInTheSand.html](http://www.cse.ohiostate.edu/siefast/nest/nest_webpage/ALineInTheSand.html)
- Network Centric Warfare Department of Defense (2001) Report to Congress, Appendix, 27 July 2001. From: [http://www.defenselink.mil/cio-nii/docs/pt3\\_ncw\\_appendix.pdf](http://www.defenselink.mil/cio-nii/docs/pt3_ncw_appendix.pdf).
- Network Management Basics (2006) Retrieved 20 April, 2006. From: [http://www.cisco.com/univercd/cc/td/doc/cisintwk/ito\\_doc/nmbasics.htm#xtocid3](http://www.cisco.com/univercd/cc/td/doc/cisintwk/ito_doc/nmbasics.htm#xtocid3).
- Newman, H. E., Ellisman, M.H., and Orcutt, J.A. (2003). Data Intensive E-Science Frontier Research. Communications of the ACM, Vol. 46(11), pp. 68-77.

- NIDDK (2005) National Health Interview Survey estimates projected to year 2005. From:  
<http://diabetes.niddk.nih.gov/dm/pubs/statistics/index.htm#treatment>.
- NIDDK (2006) Diabetes Endocrinology and metabolic Diseases. From:  
[http://www.niddk.nih.gov/federal/advances/2006/Diabetes\\_Endocrinology\\_and\\_Metabolic\\_Diseases.pdf](http://www.niddk.nih.gov/federal/advances/2006/Diabetes_Endocrinology_and_Metabolic_Diseases.pdf).
- Nonin Finger Clip (2007) From:  
<http://www.nonin.com/productsList.asp?PageID=2007&sec=1&sub=7>.
- Noury, N., Herve, T., Rialle, V., Virone, G., Mercier, E., Morey, G., Moro, A. and Porcheron, T. (2000) Monitoring behavior in home using a smart fall sensor and position sensors. *Microtechnologies in Medicine and Biology, 1st Annual International, Conference On.*, pp.607-610.
- OECD (2001) Health Data. From:  
[http://www.jetro.go.jp/jp/j/Access/iryofukushi\\_shiryo.pdf](http://www.jetro.go.jp/jp/j/Access/iryofukushi_shiryo.pdf).
- Oetiker, T. (2006) MRTG: Multi Router Traffic Ghraper. From:  
<http://www.mrtg.org>.
- Oetiker (2005) From:  
<http://people.eeh.ethz.ch/~oetiker/webtools/mrtg/users.html>.
- Ogden, C., Curtin, McDowell, Tabak, and Flegal. (2006). Prevalence of Overweight and Obesity in the United States. *JAMA*, Vol. 295(13), pp. 1549-1555.
- Ooi, P., Culjak, G. and Lawrence, E. (2005) Wireless and wearable overview: stages of growth theory in medical technology applications. *International Conference on Mobile Business, 2005. ICMB 2005*. pp. 528.
- Ortiz, S. (2007). *Brain-Computer Interfaces:Where Human and Machine Meet*. *Computer*, Vol. 40(1), pp. 17 -21.
- Osler M., Jorgensen. T., Gerdes L.U., Scand J. (2002) Changes in community and individual level psychosocial coronary risk factors in the Danish MONICA population, 1982-92. *Public Health*, Vol. 30(1), pp. 36-40.
- Pavesi, V. (2005) Retrieved 29 January, 2007. *HealthMonitor*. From:  
<http://www.securityfocus.com/tools/3552>.
- PDA (2006) Personal Digital Assistant. From:  
[http://en.wikipedia.org/wiki/Personal\\_digital\\_assistant](http://en.wikipedia.org/wiki/Personal_digital_assistant).

- Pentland (2004) Healthwear: medical technology becomes wearable. *Computer*, vol. 37, no. 5, p. 42.
- Perillo, M. and Heinselman, W. (2006) Sensor Management. In Raghavendra et al (Ed.), *Wireless Sensor Networks*: 351-372: Springer.
- Peter Leijdekkers, Valérie Gay, Elaine Lawrence: Smart Homecare System for Health Tele-monitoring. *ICDS 2007*: 3
- Petriu E.M., G. N. D., Petriu D.C., Makrakis D., Groza V.Z. (2000). Sensor-based information appliances. *IEEE Instrumentation and Measurement Magazine*, pp. 31–35.
- Polastre, J., Szewczyk, R., Mainwaring, A., Culler, D. and Anderson, J. (2006) Analysis of Wireless Sensor Networks for Habitat Monitoring. in RAGHAVENDRA (Ed.) *Wireless Sensor Networks*.
- Pollard, R. (2005). Doctors and insurers unite to reduce errors. *The Sydney Morning Herald*. From: <http://www.smh.com.au/news/National/Doctors-and-insurers-unite-to-reduce-errors/2005/01/25/1106415598626.html>.
- Pollard, R. (2006). Nurse shortage still plagues NSW hospitals. *The Sydney Morning Herald*. From: <http://www.smh.com.au/news/national/nurse-shortage-still-plagues-nsw-hospitals/2006/12/12/1165685656647.html>.
- PostgreSQL (2006). From: <http://www.postgresql.org/>.
- Rabaey J.M., Ammer M. J., J.L. da Silva Jr., Patel D. and Roundy S. (2002) PicoRadio supports ad hoc ultra-low power. *Computer Networks*, vol. 33, no. 7, pp. 393–422
- Raghunathan V., S. C., Park S. and Srivastava M. (2006). Energy efficient Design of Wireless Sensor Nodes. *Wireless Sensor Networks*, pp. 51-69.
- Raskin, J. (2000) *The humane interface : New Directions for Designing Interactive Systems*, Addison-Wesley.
- Raskovic (2004) Medical Monitoring Applications for Wearable Computing. *The computer journal*, vol. 47, no. 4, p. 495.
- Rhodes, B. and Starner T. (1996). Remembrance Agent: A continuously running automated information retrieval system. *The Proceedings of The First International Conference on The Practical Application Of Intelligent Agents and Multi Agent Technology (PAAM '96)*, pp. 487-495.

- Richardson W. C., B. D. M., Bisgard J. C., Newhall C., Melker R. J. and Brennan T. A. (2000) To Err Is Human. The Institute of Medicine (IOM). From: <http://content.nejm.org/cgi/content/short/343/9/663>.
- Rieki J., H. J. P., Ala-Siuru P., Alahuhta P., Kaartinene J. and Roning J. . (2000). Genie of the Net: Context Aware Information Management. From: <http://www.pbol.org/projects/genie/publications/infomanage.pdf>.
- Rieki, J., Huhtine, J.P., Ala-Siuru, P., Alahuhta, P., Kaartinene, J. and Roning, J. (2000) Genie of the Net: Context Aware Information Management. From: <http://www.pbol.org/projects/genie/publications/infomanage.pdf> .
- Ringland, S.P.A. and Scahill, F.J. (2003) Multimodality -- The Future of the Wireless User Interface. BT Technology Journal, vol. 21, no. 3, p. 181.
- Riudavets J., Felix Navarro K., Lawrence E., Steele R., Messina M. (2004). Multi Router Traffic Grapher for Body Area Network Surveillance. WSEAS Journal on Applied Informatics and Communications.
- Riudavets, J., Felix-Navarro, K., Lawrence, E., Steele, R. and Messina, M. (2004) Multi Router Traffic Grapher for Body Area Network Surveillance. WSEAS Journal on Applied Informatics and Communications, December, 2004.
- Riudavets, J., Navarro, K., Lawrence, E., Steele, R. and Messina, M. (2004) Multi Router Traffic Grapher (MRTG) for Body Area Network (BAN) Surveillance. fourth WSEAS International Conference on Applied Informatics and Communications.
- Ross, P.E. (December 2004) Managing Care Through the Air. IEEE Spectrum, pp. 14 -19.
- Roundy Shad, W. P. K., and Rabaey Jan (July 2003). A study of low level vibrations as a power source for wireless sensor nodes. Computer Communications, Vol. 26(11), pp. 1131-1144.
- Schou, J. (2001). From gee-whiz to must-have. Health Management Technology, Vol. 22(4), pp. 44.
- Sensatex. From: <http://www.sensatex.com/>.
- Sibbald, B. (2001). Use computerized systems to cut adverse drug events: report. CMAJ: Canadian Medical Association Journal, Vol. 164(13).
- SOSUS (2006) From: <http://www.dosits.org/gallery/tech/pt/sosus1.htm>.

- Stanford, V. (2004). Biosignals Offer Potential for Direct Interfaces and Health Monitoring. *IEEE Pervasive Computing*, Vol. 3, pp. 99-103.  
From:  
<http://ieeexplore.ieee.org/iel5/7756/28394/01269140.pdf?isnumber=&arnumber=1269140>.
- Starfield, B. (July 26th, 2000). The JOURNAL of the AMERICAN MEDICAL ASSOCIATION (JAMA), Vol. Vol 284(No 4). From:  
[http://www.cancure.org/medical\\_errors.htm](http://www.cancure.org/medical_errors.htm).
- Stargate (2005) Stargate: A PlatformX Project. From:  
<http://platformx.sourceforge.net>.
- Subramanian, M. (2000) Network Management: Principles and Practice: Addison Wesley.
- Tanenbaum, A. S., Gamage, C. and Crispo, B. (August 2006). Taking Sensor networks from the lab to the Jungle' Computer. Vol. 39(8), pp. 98-100.
- The Economist (2005) The Doctor in your Pocket. *The Economist Technology Quarterly*, pp. 8.
- Tobias, J. and Weeks, M. S. (2007) Introduction to Cloud 9; Connecting Clinicians for Better Health Care. Advanced Technologies and New markets and Internet Business Solutions Group, Cisco Systems. Sydney.
- TriangleCables. From: <http://www.trianglecables.com/>.
- ttdp (2006) The Scientist and Engineer's Guide to TinyOS Programming. From: <http://ttdp.org/tpg/html/book/book1.htm>.
- UART (2006) From: <http://en.wikipedia.org/wiki/UART>.
- United Nations World Population Prospects (200) Revision. From:  
[http://www.jetro.go.jp/jp/j/Access/iryofukushi\\_shiryo.pdf](http://www.jetro.go.jp/jp/j/Access/iryofukushi_shiryo.pdf).
- US Census Bureau (2004) From: <http://www.census.gov/>.
- Verichip (2006) From: <http://www.msnbc.msn.com/id/6237364/>.
- VitalDust (2006) From:  
<http://www.eecs.harvard.edu/~mdw/proj/vitaldust/>.
- Warneke B., L. B., K. S.J. Pister (January 2001). Smart dust: communicating with a cubic-millimeter computer. *IEEE Computer*, pp. 2-9.
- Warren, J. (2006) HINZ 2006. From: <http://www.hinz.org.nz/>.



- Webopedia (2006) Jupitermedia Corporation. From:  
<http://www.webopedia.com/>.
- Widya I., Halteren A. V., Jones V., Bults R. and Konstantas D. (2003) Telematic Requirements for a Mobile and Wireless healthcare System derived from Enterprise Models. ConTEL
- Widya, I., Peuscher, J., Vierhout, P. et al (2001) Telematic Requirements for a Mobile and Wireless Healthcare System derived from Enterprise Models. MobiHealth IST-2001-36006. University of Twente, The Netherlands.
- Wikipedia (2006) Proof of Concept. From:  
[http://en.wikipedia.org/wiki/Proof\\_of\\_concept](http://en.wikipedia.org/wiki/Proof_of_concept).
- Wikipedia (2007) Definition of OIDs.
- Wikipedia. (2006). From:  
[http://en.wikipedia.org/wiki/Sensor\\_network#History](http://en.wikipedia.org/wiki/Sensor_network#History).
- Wikipedia. From: [http://en.wikipedia.org/wiki/OSI\\_model](http://en.wikipedia.org/wiki/OSI_model).
- Wolfgang Schneider (1999) Prototyping in der software-entwicklung.  
[http://www.ergo-online.de/site.aspx?url=html/software/software\\_entwicklung\\_prototyp/protot\\_konzept.htm](http://www.ergo-online.de/site.aspx?url=html/software/software_entwicklung_prototyp/protot_konzept.htm),
- Xbow (2006). From:  
[http://www.xbow.com/Support/Support\\_pdf\\_files/MPR-MIB\\_Series\\_Users\\_Manual.pdf](http://www.xbow.com/Support/Support_pdf_files/MPR-MIB_Series_Users_Manual.pdf).
- Ye, W., and Heidemann, J. (May 2004). Medium Access Control In Wireless Sensor Networks. In K. M. Taieb Znati, Sivalingam and Cauligi Raghavendra (Ed.), *Wireless Sensor Networks*, Chapter 4: 73-91: Kluwer Academic Publishers.
- Yen Yang Lim, Messina, M., Kargl, F., Ganguli, L., Fischer, M. and Tsang, T. (2008) SNMP-Proxy For Wireless Sensor Network, IEEE ITNG Conference, Las Vegas, 7-9 April, 2008.
- Zigbee Alliance (2006). From: <http://www.zigbee.org>.
- Zimmer, C. (2003) Newsweek International, pp. 76 - 80.
- Ziv, N.D. (2005) Toward a New Paradigm of Innovation on the Mobile Platform: Redefining the Roles of Content Providers, Technology Companies, and Users, International Conference on Mobile Business 2005. pp. 152.

# Appendix A

#	SCENARIO	3:00	1	min.	relaxing	30sec deep breathing holding breath as long as possible
#	ID	102:00:00	Y.			
#	ID	105:00:00	L.K.G.			
10	Sep	2007	24:19.8	EST	:	patientID 105 PULSE 134
10	Sep	2007	24:20.7	EST	:	patientID 105 PULSE 134
10	Sep	2007	24:21.7	EST	:	patientID 105 OXYGEN 98
10	Sep	2007	24:22.7	EST	:	patientID 105 PULSE 135
10	Sep	2007	24:22.7	EST	:	patientID 105 OXYGEN 99
10	Sep	2007	24:23.2	EST	:	patientID 102 OXYGEN 98
10	Sep	2007	24:23.6	EST	:	patientID 105 PULSE 135
10	Sep	2007	24:23.7	EST	:	patientID 105 OXYGEN 99
10	Sep	2007	24:24.1	EST	:	patientID 102 OXYGEN 98
10	Sep	2007	24:24.6	EST	:	patientID 105 PULSE 135
10	Sep	2007	24:24.6	EST	:	patientID 105 OXYGEN 99
10	Sep	2007	24:25.1	EST	:	patientID 102 PULSE 93
10	Sep	2007	24:25.6	EST	:	patientID 105 PULSE 135
10	Sep	2007	24:25.6	EST	:	patientID 105 OXYGEN 99
10	Sep	2007	24:26.1	EST	:	patientID 102 OXYGEN 98
10	Sep	2007	24:26.1	EST	:	patientID 102 PULSE 92
10	Sep	2007	24:26.6	EST	:	patientID 105 PULSE 134
10	Sep	2007	24:26.6	EST	:	patientID 105 OXYGEN 99
10	Sep	2007	24:27.1	EST	:	patientID 102 OXYGEN 98
10	Sep	2007	24:27.1	EST	:	patientID 102 PULSE 92
10	Sep	2007	24:27.6	EST	:	patientID 105 PULSE 134
10	Sep	2007	24:27.6	EST	:	patientID 105 OXYGEN 98
10	Sep	2007	24:28.0	EST	:	patientID 102 OXYGEN 98
10	Sep	2007	24:28.0	EST	:	patientID 102 PULSE 90
10	Sep	2007	24:28.5	EST	:	patientID 105 PULSE 134
10	Sep	2007	24:28.5	EST	:	patientID 105 OXYGEN 97
10	Sep	2007	24:29.0	EST	:	patientID 102 OXYGEN 98
10	Sep	2007	24:29.0	EST	:	patientID 102 PULSE 90
10	Sep	2007	24:29.5	EST	:	patientID 105 PULSE 133
10	Sep	2007	24:29.5	EST	:	patientID 105 OXYGEN 97

10	Sep	2007	24:30.0	EST	:	patientID	102	OXYGEN	98
10	Sep	2007	24:30.0	EST	:	patientID	102	PULSE	90
10	Sep	2007	24:30.5	EST	:	patientID	105	PULSE	133
10	Sep	2007	24:30.5	EST	:	patientID	105	OXYGEN	97
10	Sep	2007	24:31.0	EST	:	patientID	102	OXYGEN	98
10	Sep	2007	24:31.0	EST	:	patientID	102	PULSE	90
10	Sep	2007	24:31.5	EST	:	patientID	105	PULSE	133
10	Sep	2007	24:31.9	EST	:	patientID	102	OXYGEN	98
10	Sep	2007	24:32.0	EST	:	patientID	102	PULSE	90
10	Sep	2007	24:32.5	EST	:	patientID	105	PULSE	132
10	Sep	2007	24:32.5	EST	:	patientID	105	OXYGEN	97
10	Sep	2007	24:32.9	EST	:	patientID	102	OXYGEN	98
10	Sep	2007	24:32.9	EST	:	patientID	102	PULSE	90
10	Sep	2007	24:33.4	EST	:	patientID	105	PULSE	132
10	Sep	2007	24:33.4	EST	:	patientID	105	OXYGEN	97
10	Sep	2007	24:33.9	EST	:	patientID	102	OXYGEN	98
10	Sep	2007	24:33.9	EST	:	patientID	102	PULSE	90
10	Sep	2007	24:34.4	EST	:	patientID	105	PULSE	132
10	Sep	2007	24:34.4	EST	:	patientID	105	OXYGEN	97
10	Sep	2007	24:34.9	EST	:	patientID	102	OXYGEN	98
10	Sep	2007	24:34.9	EST	:	patientID	102	PULSE	91
10	Sep	2007	24:35.4	EST	:	patientID	105	PULSE	132
10	Sep	2007	24:35.4	EST	:	patientID	105	OXYGEN	97
10	Sep	2007	24:35.8	EST	:	patientID	102	OXYGEN	98
10	Sep	2007	24:35.9	EST	:	patientID	102	PULSE	92
10	Sep	2007	24:36.4	EST	:	patientID	105	PULSE	133
10	Sep	2007	24:36.4	EST	:	patientID	105	OXYGEN	97
10	Sep	2007	24:36.8	EST	:	patientID	102	OXYGEN	98
10	Sep	2007	24:36.8	EST	:	patientID	102	PULSE	92
10	Sep	2007	24:37.4	EST	:	patientID	105	PULSE	133
10	Sep	2007	24:37.4	EST	:	patientID	105	OXYGEN	97
10	Sep	2007	24:37.8	EST	:	patientID	102	OXYGEN	98
10	Sep	2007	24:37.8	EST	:	patientID	102	PULSE	91
10	Sep	2007	24:38.3	EST	:	patientID	105	PULSE	133
10	Sep	2007	24:38.3	EST	:	patientID	105	OXYGEN	97
10	Sep	2007	24:38.8	EST	:	patientID	102	OXYGEN	98
10	Sep	2007	24:38.8	EST	:	patientID	102	PULSE	91
10	Sep	2007	24:39.3	EST	:	patientID	105	PULSE	132
10	Sep	2007	24:39.3	EST	:	patientID	105	OXYGEN	97
10	Sep	2007	24:39.8	EST	:	patientID	102	OXYGEN	98
10	Sep	2007	24:39.8	EST	:	patientID	102	PULSE	92
10	Sep	2007	24:40.3	EST	:	patientID	105	PULSE	131
10	Sep	2007	24:40.3	EST	:	patientID	105	OXYGEN	97

10	Sep	2007	24:40.8	EST	:	patientID	102	OXYGEN	97
10	Sep	2007	24:40.8	EST	:	patientID	102	PULSE	92
10	Sep	2007	24:41.3	EST	:	patientID	105	PULSE	130
10	Sep	2007	24:41.3	EST	:	patientID	105	OXYGEN	97
10	Sep	2007	24:41.7	EST	:	patientID	102	OXYGEN	98
10	Sep	2007	24:41.7	EST	:	patientID	102	PULSE	94
10	Sep	2007	24:42.2	EST	:	patientID	105	PULSE	130
10	Sep	2007	24:42.3	EST	:	patientID	105	OXYGEN	97
10	Sep	2007	24:42.7	EST	:	patientID	102	OXYGEN	98
10	Sep	2007	24:42.7	EST	:	patientID	102	PULSE	94
10	Sep	2007	24:43.2	EST	:	patientID	105	PULSE	130
10	Sep	2007	24:43.2	EST	:	patientID	105	OXYGEN	97
10	Sep	2007	24:43.7	EST	:	patientID	102	OXYGEN	98
10	Sep	2007	24:43.7	EST	:	patientID	102	PULSE	94
10	Sep	2007	24:44.2	EST	:	patientID	105	PULSE	131
10	Sep	2007	24:44.2	EST	:	patientID	105	OXYGEN	97
10	Sep	2007	24:44.7	EST	:	patientID	102	OXYGEN	98
10	Sep	2007	24:44.7	EST	:	patientID	102	PULSE	95
10	Sep	2007	24:45.2	EST	:	patientID	105	PULSE	131
10	Sep	2007	24:45.2	EST	:	patientID	105	OXYGEN	96
10	Sep	2007	24:45.7	EST	:	patientID	102	OXYGEN	98
10	Sep	2007	24:45.7	EST	:	patientID	102	PULSE	95
10	Sep	2007	24:46.1	EST	:	patientID	105	PULSE	130
10	Sep	2007	24:46.1	EST	:	patientID	105	OXYGEN	96
10	Sep	2007	24:46.6	EST	:	patientID	102	OXYGEN	98
10	Sep	2007	24:46.6	EST	:	patientID	102	PULSE	96
10	Sep	2007	24:47.1	EST	:	patientID	105	PULSE	130
10	Sep	2007	24:47.1	EST	:	patientID	105	OXYGEN	94
10	Sep	2007	24:47.6	EST	:	patientID	102	OXYGEN	97
10	Sep	2007	24:47.6	EST	:	patientID	102	PULSE	95
10	Sep	2007	24:48.1	EST	:	patientID	105	PULSE	131
10	Sep	2007	24:48.1	EST	:	patientID	105	OXYGEN	94
10	Sep	2007	24:48.6	EST	:	patientID	102	OXYGEN	97
10	Sep	2007	24:48.6	EST	:	patientID	102	PULSE	95
10	Sep	2007	24:49.1	EST	:	patientID	105	PULSE	131
10	Sep	2007	24:49.6	EST	:	patientID	102	OXYGEN	97
10	Sep	2007	24:49.6	EST	:	patientID	102	PULSE	95
10	Sep	2007	24:50.1	EST	:	patientID	105	PULSE	131
10	Sep	2007	24:50.6	EST	:	patientID	102	OXYGEN	97
10	Sep	2007	24:50.6	EST	:	patientID	102	PULSE	94
10	Sep	2007	24:51.0	EST	:	patientID	105	PULSE	132
10	Sep	2007	24:51.1	EST	:	patientID	105	OXYGEN	95
10	Sep	2007	24:51.5	EST	:	patientID	102	OXYGEN	97

10	Sep	2007	24:51.5	EST	:	patientID	102	PULSE	95
10	Sep	2007	24:52.0	EST	:	patientID	105	PULSE	132
10	Sep	2007	24:52.0	EST	:	patientID	105	OXYGEN	97
10	Sep	2007	24:52.5	EST	:	patientID	102	OXYGEN	97
10	Sep	2007	24:52.5	EST	:	patientID	102	PULSE	95
10	Sep	2007	24:53.0	EST	:	patientID	105	PULSE	132
10	Sep	2007	24:53.0	EST	:	patientID	105	OXYGEN	97
10	Sep	2007	24:53.5	EST	:	patientID	102	OXYGEN	97
10	Sep	2007	24:53.5	EST	:	patientID	102	PULSE	95
10	Sep	2007	24:54.0	EST	:	patientID	105	PULSE	132
10	Sep	2007	24:54.0	EST	:	patientID	105	OXYGEN	97
10	Sep	2007	24:54.5	EST	:	patientID	102	OXYGEN	98
10	Sep	2007	24:54.5	EST	:	patientID	102	PULSE	96
10	Sep	2007	24:55.0	EST	:	patientID	105	PULSE	132
10	Sep	2007	24:55.0	EST	:	patientID	105	OXYGEN	97
10	Sep	2007	24:55.5	EST	:	patientID	102	OXYGEN	99
10	Sep	2007	24:55.5	EST	:	patientID	102	PULSE	98
10	Sep	2007	24:55.9	EST	:	patientID	105	PULSE	132
10	Sep	2007	24:55.9	EST	:	patientID	105	OXYGEN	97
10	Sep	2007	24:56.4	EST	:	patientID	102	OXYGEN	99
10	Sep	2007	24:56.4	EST	:	patientID	102	PULSE	98
10	Sep	2007	24:56.9	EST	:	patientID	105	PULSE	132
10	Sep	2007	24:56.9	EST	:	patientID	105	OXYGEN	97
10	Sep	2007	24:57.4	EST	:	patientID	102	OXYGEN	99
10	Sep	2007	24:57.4	EST	:	patientID	102	PULSE	98
10	Sep	2007	24:57.9	EST	:	patientID	105	PULSE	132
10	Sep	2007	24:57.9	EST	:	patientID	105	OXYGEN	98
10	Sep	2007	24:58.4	EST	:	patientID	102	OXYGEN	99
10	Sep	2007	24:58.4	EST	:	patientID	102	PULSE	98
10	Sep	2007	24:58.9	EST	:	patientID	105	PULSE	133
10	Sep	2007	24:58.9	EST	:	patientID	105	OXYGEN	98
10	Sep	2007	24:59.4	EST	:	patientID	102	OXYGEN	99
10	Sep	2007	24:59.4	EST	:	patientID	102	PULSE	98
10	Sep	2007	24:59.8	EST	:	patientID	105	PULSE	134
10	Sep	2007	25:00.3	EST	:	patientID	102	OXYGEN	99
10	Sep	2007	25:00.4	EST	:	patientID	102	PULSE	98
10	Sep	2007	25:00.8	EST	:	patientID	105	PULSE	134
10	Sep	2007	25:00.8	EST	:	patientID	105	OXYGEN	98
10	Sep	2007	25:01.3	EST	:	patientID	102	OXYGEN	99
10	Sep	2007	25:01.3	EST	:	patientID	102	PULSE	98
10	Sep	2007	25:01.8	EST	:	patientID	105	PULSE	134
10	Sep	2007	25:01.8	EST	:	patientID	105	OXYGEN	97
10	Sep	2007	25:02.3	EST	:	patientID	102	OXYGEN	99

10	Sep	2007	25:02.3	EST	:	patientID	102	PULSE	98
10	Sep	2007	25:02.8	EST	:	patientID	105	PULSE	134
10	Sep	2007	25:02.8	EST	:	patientID	105	OXYGEN	97
10	Sep	2007	25:03.3	EST	:	patientID	102	OXYGEN	99
10	Sep	2007	25:03.3	EST	:	patientID	102	PULSE	98
10	Sep	2007	25:03.8	EST	:	patientID	105	PULSE	134
10	Sep	2007	25:03.8	EST	:	patientID	105	OXYGEN	97
10	Sep	2007	25:04.2	EST	:	patientID	102	OXYGEN	99
10	Sep	2007	25:04.3	EST	:	patientID	102	PULSE	97
10	Sep	2007	25:04.7	EST	:	patientID	105	PULSE	133
10	Sep	2007	25:04.8	EST	:	patientID	105	OXYGEN	97
10	Sep	2007	25:05.2	EST	:	patientID	102	OXYGEN	99
10	Sep	2007	25:05.2	EST	:	patientID	102	PULSE	97
10	Sep	2007	25:05.7	EST	:	patientID	105	PULSE	133
10	Sep	2007	25:05.7	EST	:	patientID	105	OXYGEN	97
10	Sep	2007	25:06.2	EST	:	patientID	102	OXYGEN	99
10	Sep	2007	25:06.2	EST	:	patientID	102	PULSE	97
10	Sep	2007	25:06.7	EST	:	patientID	105	PULSE	133
10	Sep	2007	25:06.7	EST	:	patientID	105	OXYGEN	97
10	Sep	2007	25:07.2	EST	:	patientID	102	OXYGEN	99
10	Sep	2007	25:07.2	EST	:	patientID	102	PULSE	97
10	Sep	2007	25:07.7	EST	:	patientID	105	PULSE	132
10	Sep	2007	25:07.7	EST	:	patientID	105	OXYGEN	98
10	Sep	2007	25:08.2	EST	:	patientID	102	OXYGEN	98
10	Sep	2007	25:08.2	EST	:	patientID	102	PULSE	96
10	Sep	2007	25:08.7	EST	:	patientID	105	PULSE	131
10	Sep	2007	25:08.7	EST	:	patientID	105	OXYGEN	98
10	Sep	2007	25:09.2	EST	:	patientID	102	OXYGEN	98
10	Sep	2007	25:09.2	EST	:	patientID	102	PULSE	96
10	Sep	2007	25:09.6	EST	:	patientID	105	PULSE	131
10	Sep	2007	25:09.7	EST	:	patientID	105	OXYGEN	97
10	Sep	2007	25:10.1	EST	:	patientID	102	OXYGEN	98
10	Sep	2007	25:10.1	EST	:	patientID	102	PULSE	96
10	Sep	2007	25:10.6	EST	:	patientID	105	PULSE	130
10	Sep	2007	25:10.6	EST	:	patientID	105	OXYGEN	97
10	Sep	2007	25:11.1	EST	:	patientID	102	OXYGEN	98
10	Sep	2007	25:11.1	EST	:	patientID	102	PULSE	95
10	Sep	2007	25:11.6	EST	:	patientID	105	PULSE	130
10	Sep	2007	25:11.6	EST	:	patientID	105	OXYGEN	97
10	Sep	2007	25:12.1	EST	:	patientID	102	OXYGEN	98
10	Sep	2007	25:12.1	EST	:	patientID	102	PULSE	94
10	Sep	2007	25:12.6	EST	:	patientID	105	PULSE	130
10	Sep	2007	25:12.6	EST	:	patientID	105	OXYGEN	97

10	Sep	2007	25:13.0	EST	:	patientID	102	OXYGEN	98
10	Sep	2007	25:13.1	EST	:	patientID	102	PULSE	94
10	Sep	2007	25:13.6	EST	:	patientID	105	PULSE	130
10	Sep	2007	25:13.6	EST	:	patientID	105	OXYGEN	97
10	Sep	2007	25:14.0	EST	:	patientID	102	OXYGEN	98
10	Sep	2007	25:14.0	EST	:	patientID	102	PULSE	94
10	Sep	2007	25:14.5	EST	:	patientID	105	PULSE	131
10	Sep	2007	25:14.6	EST	:	patientID	105	OXYGEN	97
10	Sep	2007	25:15.0	EST	:	patientID	102	OXYGEN	98
10	Sep	2007	25:15.0	EST	:	patientID	102	PULSE	95
10	Sep	2007	25:15.5	EST	:	patientID	105	PULSE	131
10	Sep	2007	25:15.5	EST	:	patientID	105	OXYGEN	97
10	Sep	2007	25:16.0	EST	:	patientID	102	OXYGEN	98
10	Sep	2007	25:16.0	EST	:	patientID	102	PULSE	95
10	Sep	2007	25:16.5	EST	:	patientID	105	PULSE	132
10	Sep	2007	25:16.5	EST	:	patientID	105	OXYGEN	97
10	Sep	2007	25:17.0	EST	:	patientID	102	OXYGEN	98
10	Sep	2007	25:17.0	EST	:	patientID	102	PULSE	95
10	Sep	2007	25:17.5	EST	:	patientID	105	PULSE	134
10	Sep	2007	25:17.5	EST	:	patientID	105	OXYGEN	96
10	Sep	2007	25:17.9	EST	:	patientID	102	OXYGEN	98
10	Sep	2007	25:18.0	EST	:	patientID	102	PULSE	98
10	Sep	2007	25:18.4	EST	:	patientID	105	PULSE	135
10	Sep	2007	25:18.5	EST	:	patientID	105	OXYGEN	96
10	Sep	2007	25:18.9	EST	:	patientID	102	OXYGEN	98
10	Sep	2007	25:18.9	EST	:	patientID	102	PULSE	98
10	Sep	2007	25:19.4	EST	:	patientID	105	PULSE	136
10	Sep	2007	25:19.4	EST	:	patientID	105	OXYGEN	96
10	Sep	2007	25:19.9	EST	:	patientID	102	OXYGEN	98
10	Sep	2007	25:19.9	EST	:	patientID	102	PULSE	99
10	Sep	2007	25:20.4	EST	:	patientID	105	PULSE	136
10	Sep	2007	25:20.9	EST	:	patientID	102	OXYGEN	98
10	Sep	2007	25:20.9	EST	:	patientID	102	PULSE	100
10	Sep	2007	25:21.4	EST	:	patientID	105	PULSE	137
10	Sep	2007	25:21.4	EST	:	patientID	105	OXYGEN	96
10	Sep	2007	25:21.9	EST	:	patientID			

# Appendix B

## **Overall system Goals of the MoteCare and Mobile MoteCare Systems**

Remote and mobile monitoring using WSN and NM tools

### **MoteCare Overall System Description**

Use of Motes or other commodity-based technology as underlying sensor network

Sensor network would monitor the patient's vital statistics and surrounding environment continuously. Information from this network will be forwarded to a remote, local or mobile client. The information can also be presented in real-time or periodically. The underlying sensor network can also be modified to fit the patient's need. The system would intelligently monitor the patient and warn of any detection of the patient's condition to a medical centre.

### **MoteCare and Mobile MoteCare System Goals**

Employ a PDA for real time mobile monitoring of the patient

Maintain MRTG on the server side to monitor the patients

Partial implementation of overall system

### **Testing Goals**

Test the usability of the system; how easy is the system to use and how well is the information presented. Will the patient consider the system to be too complex?



## **System Components**

MRTG web server

Motes sensor network

    Light sensor

Desktop/notebook computer

PDA

## **Mobile MoteCare Prototype System Description**

Sensor network is directly connected via the base station to the PDA. The network only streams sensor information to the PDA, which presents and forwards the data to the MRTG web server, located on the desktop. MRTG gathers the information and presents them on a graph, which is updated every five minutes. The PDA presents the information as soon as it receives the data.

## **Testing Duration**

1-2 hours (at least 1 hour must be attended)

## **Testing Tasks**

Setup – Sensor network (this should normally be done without much user involvement):

Place motes around room, but not outside room

Setup – Computer: (this can be done in a remote location)

- Open Internet browser
- Type: ".../mote1.html" on the address bar
- Open another internet browser
- Type ".../mote2.html" on the address bar
- Setup – PDA
- Turn on PDA (found on top of the PDA – silver button)
- Using stylus, press on "Start"
- Choose "Programs" on the list that appears

- A new window opens, look for and press –using stylus – on “File Explorer”
- Another new window opens up, on the grey bar on top, look for “My Documents” on the left, and press on it.
- A list appears and press on “My Device” (this should be highlighted in blue)
- Now on the window of files and folders, follow these next few steps:
  - Press on “Program Files”
  - Then press on “Listen1”
  - Then press again on “Listen1”
- -Wait until program starts

Every 5 minutes:

- Periodically check values on graphs on MRTG

Every 10 minutes or so minutes:

- Toggle the light switch
- Observer change in the PDA

### **On your own choice**

- Move around the room with the PDA attached with the base station
- Leave the room for at least 5 minutes and then return, observe the changes

In all steps:

- Record actions and observations on the Observations form

### **Testing Documents**

- Observations form
- Feedback survey and comments form