

Collected Works Related to the Development of the Modern Cochlear Implant

by

Professor Blake S. Wilson

A thesis presented to the
University of Technology Sydney

In fulfillment of the
thesis requirement for the
degree

Higher Doctorate

December 2014

Students are required to make a declaration when they submit the thesis for examination. Here is a recommended form of words.

CERTIFICATE OF AUTHORSHIP/ORIGINALITY

I certify that the work in this thesis has not previously been submitted for a degree nor has it been submitted as part of requirements for a degree except as fully acknowledged within the text.

I also certify that the thesis has been written by me. Any help that I have received in my research work and the preparation of the thesis itself has been acknowledged. In addition, I certify that all information sources and literature used are indicated in the thesis.

Signature of Candidate

Production Note:
Signature removed prior to publication.

Abstract

This thesis for a higher doctorate in engineering at the University of Technology, Sydney (UTS) presents collected works related to the development of the modern cochlear implant, a prosthesis that restores useful hearing for deaf or severely hearing impaired persons. The emphasis is on the engineering aspects of the development, and the principal work for this thesis is the book *Better Hearing with Cochlear Implants: Studies at the Research Triangle Institute*, which is a major engineering treatise. In addition, ten further publications are included that also describe engineering aspects of the development. This bounded thesis includes the ten further publications, an acknowledgments section, a published review of the book, a one-page biographical sketch for the author, and the author's full CV. The book is available separately at the UTS Library or from the publisher, Plural Publishing, Inc., of San Diego, CA, USA.

Contents

Acknowledgments	6
Publications	7
1. Wilson BS, Finley CC, Lawson DT, Wolford RD: Speech processors for cochlear prostheses. Proc IEEE 76: 1143-1154, 1988	7
2. Wilson BS, Finley CC, Lawson DT, Wolford RD, Zerbi M: Design and evaluation of a continuous interleaved sampling (CIS) processing strategy for multichannel cochlear implants. J Rehab Res Devel 30: 110-116, 1993	19
3. Wilson BS: Thirty years of the British Journal of Audiology: Guest Editorial: The future of cochlear implants. Brit J Audiol 31: 205-225, 1997	26
4. Wilson BS: Engineering design of cochlear implants. In <i>Cochlear Implants: Auditory Prostheses and Electric Hearing</i> , edited by F-G Zeng, AN Popper and RR Fay, Springer-Verlag, New York, pp. 14-52, 2004	47
5. Wilson BS, Schatzer R, Lopez-Poveda EA, Sun X, Lawson DT, Wolford RD: Two new directions in speech processor design for cochlear implants. Ear Hear 26: 73S-81S, 2005	86
6. Wilson BS, Dorman MF: The surprising performance of present-day cochlear implants. IEEE Trans Biomed Eng 54: 969-972, 2007	95
7. An SK, Park SI, Jun SB, Byun KM, Lee CJ, Wilson BS, Rebscher SJ, Kim SJ: Design for a simplified cochlear implant system. IEEE Trans Biomed Eng 54: 973-982, 2007	99

8. Wilson BS, Dorman MF: Interfacing sensors with the nervous system: Lessons from the development and success of cochlear implants. <i>IEEE Sensors J</i> 8: 131-147, 2008	109
9. Wilson BS, Dorman MF: Signal processing strategies for cochlear implants. In <i>Cochlear Implants and Other Implantable Hearing Devices</i> , edited by MJ Ruckenstein. Plural Publishing, San Diego, CA, pp. 51-84, 2012	126
10. Wilson BS: Toward better representations of sound with cochlear implants. <i>Nature Med</i> 19: 1245-1248, 2013	160
Review by Professor Mario Svirsky of <i>Better Hearing with Cochlear Implants</i>	164
One-page biographical sketch for Professor Blake S. Wilson	165
CV for Professor Blake S. Wilson	166

Acknowledgments

In looking back over my career, I have many people to thank for helping me and the teams I have directed. Most of these people are named in the Acknowledgements section of the book included as a part of this thesis. I have been blessed to have known these wonderful and talented people and to have had the grand opportunities to work with them.

I also am most grateful indeed for the expert and selfless help given to me in connection with my submission for a higher doctorate at the University of Technology, Sydney (UTS). The persons at the UTS who so generously helped me include Dean and Professor Hung Nguyen; Dean and Professor Nicky Solomon; Executive Assistant Maree Jouliau; Senior Deputy Vice Chancellor and Vice President Peter Booth; and Deputy Vice Chancellor and Vice President for Research Attila Brungs, who now is the Vice Chancellor and President.

I am so very proud and happy to be associated with this magnificent university and its spectacular people and programs. Sometimes I cannot believe my great good fortune, made possible by my family and many friends and colleagues worldwide.

Speech Processors for Cochlear Prostheses

BLAKE S. WILSON, MEMBER, IEEE, CHARLES C. FINLEY, MEMBER, IEEE,
DEWEY T. LAWSON, AND ROBERT D. WOLFORD

This paper reviews considerations in the design of speech processors for cochlear prostheses. Background material is presented on aspects of normal hearing, patterns of nerve survival in the deaf ear, elements of speech essential for intelligibility, and the psychophysics of direct electrical stimulation of the cochlea. Then, to illustrate issues of processor design, two fundamentally different processing strategies are described in terms of the information that they can convey and in terms of how they might perform under various conditions of nerve survival. A summary of clinical tests comparing these strategies in eight implant patients follows. Key findings from the comparison studies are that a) one processor is clearly superior for patients with psychophysical signs of poor nerve survival, b) the other processor may be superior for patients with signs of good survival, and c) different processing strategies can produce widely different outcomes for individual patients. The implications of these findings are discussed with an emphasis on interpretations relating to nerve survival. Future directions in the further development of speech processors for cochlear prostheses are outlined in a final section.

INTRODUCTION

The design of speech processors for cochlear prostheses is a multifaceted activity. At the most basic level such processors must extract or preserve from speech those parameters that are essential for intelligibility and then encode those parameters for electrical stimulation of the auditory nerve. Areas of knowledge necessary to the informed design of speech processors for cochlear prostheses include electrical engineering and the speech and hearing sciences. The range of options for processor design is quite large—a latitude reflected in the many approaches that have been taken in the design of clinically-applied devices [1]–[4].

A remarkable finding from evaluations of these approaches is that each of several distinctly different processing strategies can produce high levels of speech perception in some patients. Unfortunately the converse is also true, in that poor levels of performance are found for other patients using the same strategies. A likely contributor to

Manuscript received November 18, 1987; revised March 29, 1988. This work was supported by NIH Contracts NO1-NS-3-2356 and NO1-NS-5-2396, through the Neural Prosthesis Program.

B. S. Wilson, C. C. Finley, and D. T. Lawson are with the Neurosciences Program Office, Research Triangle Institute, Research Triangle Park, NC 27709, USA.

R. D. Wolford is with the Department of Surgery, Duke University Medical Center, Durham, NC 27710, USA.

IEEE Log Number 8823251.

this disparity in performance levels is variation in nerve survival among the inner ears of different implant patients. In particular, a person blessed with excellent nerve survival may be able to make good use of a wide variety of inputs, including those provided by various contemporary cochlear prostheses, while a person with poor nerve survival may not be able to utilize information from many of these same inputs.

Our work in developing speech processors has focused on determining optimal strategies for implant patients with varying degrees of nerve survival. This work has led to the development of a new class of processing strategies that has provided improved performance for patients with signs of poor nerve survival, and has demonstrated that access to a variety of alternative strategies is required to obtain the best results across the entire patient population. In this paper we will summarize some of our work, illustrating current issues in processor design. We hope the examples we present will help to a) emphasize the potential importance of variations in nerve survival as a consideration in the design and application of speech processors and b) provide the reader with a useful introduction to problems and opportunities in the further development of these devices.

BACKGROUND

Aspects of Normal Hearing

A highly simplified diagram of the peripheral auditory system is shown in Fig. 1. In normal hearing, sound waves in air cause vibrations of the eardrum that are conveyed to the inner ear via the three small bones of the middle ear. These middle ear bones act as a mechanical transformer to match impedances between sound transmission in air and sound transmission in the fluid-filled inner ear. Sound vibrations in the fluids displace a flexible membrane suspended in the spiral-shaped inner ear (or cochlea). Gradations in the mechanical properties of this membrane result in changes in frequency response as a function of position along the length of the cochlear spiral. The maximum displacements in response to high frequency stimuli occur at basal positions, near the middle ear end of the cochlea, while maximum displacements in response to low frequency stimuli occur at apical positions, near the apex of the spiral. Sensory hair cells line the top of the basilar membrane, the hairs of these cells bending in response to

0018-9219/88/0900-1143\$01.00 © 1988 IEEE

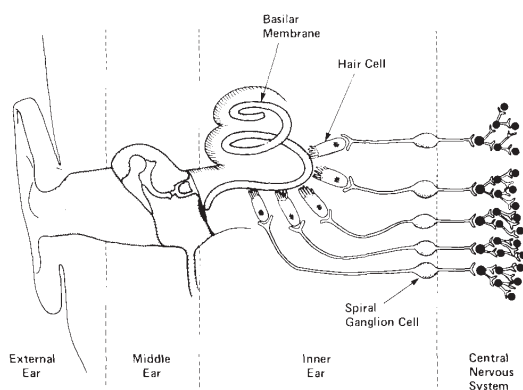

Fig. 1. Functional elements of the auditory system. (Not to scale.)

shearing displacements with respect to the overlying tectorial membrane. This bending of the hairs in turn releases chemical transmitter substance at the base of the hair cells. Sufficient concentrations of transmitter substance in the synaptic clefts between the hair cells and adjacent neurons will cause these neurons to fire, signaling the presence of excitation at some particular site in the inner ear. Each neuron includes a peripheral dendrite and axon, a ganglion cell body, and a central axon. There are approximately 30 000 neurons in the normal human ear. These neurons, collectively known as the auditory or cochlear nerve, communicate with parts of the central nervous system (CNS) that shape and interpret this input for such specific purposes as pitch discrimination, sound localization, and speech perception.

Patterns of Nerve Survival

Disruptions in any of these links between sound waves in air and auditory nerve discharge patterns can produce hearing impairment or deafness. One cause of hearing impairment, for example, is the gradual immobilization of middle ear components by bone growth, greatly reducing the efficiency of sound transmission to the inner ear. Fortunately, such deficits in hearing often can be overcome with conventional hearing aids or surgical procedures.

Another possible cause of hearing impairment is loss of sensory hair cells or auditory neurons. The hair cells are particularly fragile and can be damaged by exposure to loud sounds, by a wide range of drug treatments, by congenital disorders, and by certain diseases. Moreover, damage to the hair cells and their supporting structures can lead to subsequent degeneration of the adjacent neurons. If large numbers of sensory hair cells or auditory neurons are destroyed, the connection between the CNS and vibrating structures is severed and the person with such a loss is rendered profoundly deaf. Fortunately, present evidence indicates that loss of sensory hair cells is a far more common cause of deafness than loss of auditory neurons [5]. In such cases direct electrical stimulation can excite the remaining neurons in ways that convey useful information to the CNS. The idea of bypassing the entire vibratory path and the hair cells underlies the concept of cochlear prostheses as a treatment of deafness.

Although loss of sensory hair cells may be the principal cause of deafness, it is often accompanied by at least some loss of auditory neurons. This situation is depicted in Fig. 2. In the left panel is the pristine set of hair cells, dendrites,

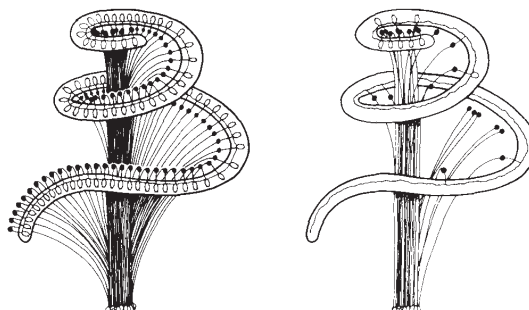

Fig. 2. Patterns of nerve and hair cell survival for normal hearing (left panel) and for a typical deaf ear (right panel). Illustration adapted from Lawrence [44].

ganglion cells, and central axons characteristic of normal hearing, while in the right panel the sparse and uneven survival of these elements typifies the deaf ear. Inferences about nerve survival in living human beings necessarily derive from psychophysical measures and from the correlation of those measures with the results of psychophysical and histological studies in animals.

A fundamental problem faced by designers of cochlear prostheses is the variability in neural survival patterns among deaf ears. This problem is particularly difficult and significant in the design of speech processors for use with implanted arrays of spatially-selective electrodes. In such systems a key objective is to exploit the "place" coding for frequency of stimulation in the normal auditory system. That is, when high frequency inputs are detected by the speech processor then appropriately-encoded stimuli are delivered to electrodes near the basal end of the cochlea, while low frequency inputs result in electrical stimulation near the apical end. The electrode array used in the majority of our studies has eight pairs of closely-spaced bipolar contacts [6]. The positions of the pairs span locations that in the normal ear correspond to a range of place frequencies from about 800 Hz to about 6000 Hz. In an implanted ear with excellent nerve survival near these positions, eight distinct sectors of excitation can be realized with a high degree of independence [7], [8]. This sector-by-sector control of nerve activity would be expected to provide a good representation of the spectral content of an acoustic input signal through appropriate adjustment of stimulus intensities at each electrode channel. However, in the more typical deaf ear, with less than complete nerve survival, such a representation of frequencies as a place code obviously will be distorted in areas of neural loss. The alternatives for dealing with areas of loss are a) to leave a "hole" in the frequency-place map in such areas or b) to raise stimulus levels to recruit more distant but still viable neurons. In either case the positions of excitation no longer simply reflect the frequency content of the acoustic input signal.

Another, probably more serious, difficulty posed by poor nerve survival is interaction among stimulated channels. Because the loudness of auditory sensations is likely to

depend in large part on the total number of activated auditory neurons [9], one might expect that relatively high levels of electrical stimulation would be required in regions of poor nerve survival to evoke comfortably-loud percepts. In systems with multichannel electrode arrays these high levels of stimulation will almost certainly produce substantial overlaps among sectors stimulated by different electrodes [10]–[12]. The resulting excitation of common subpopulations of neurons—the problem of channel interactions—can severely limit the performance of multichannel prostheses.

Elements of Speech

A simple but useful model of speech production is illustrated in Fig. 3. This “source-filter” model [13] recognizes the first-order independence of the excitation of the vocal tract and its response. Unvoiced components of speech are produced with a source of broadband turbulent noise. This noise is generated either by forcing air through a narrow constriction (for production of unvoiced fricatives like “s”) or by building air pressure behind an obstruction and suddenly releasing this pressure when the obstruction is removed (for production of plosives like “t”). The spectral characteristics of this broadband noise then are modified by transmission through the vocal tract and by radiation of sound at the lips.

In contrast, voiced components of speech are produced by “ringing” the vocal tract with puffs of air released through the vibrating folds of the glottis. The shape of the vocal tract, in terms of tongue, lip, jaw, and velum position, contributes resonances that influence sound transmission in the tract. The transfer function of the vocal tract is the “filter” of the source-filter model, and the broad spectral peaks in this transfer function are called “formants.” The frequencies of the first two formants convey sufficient information for recognition of vowels and distinctions among other voiced sounds.

A third class of speech sounds is produced by the simultaneous combination of periodic glottal excitation and aperiodic supraglottal noise sources. An example of such sounds are the voiced fricatives. The addition of voicing can change an “s” sound to a “z” sound, for instance.

Experiments with models of the type shown in Fig. 3 have demonstrated that small sets of parameters can provide adequate specification for the production of intelligible speech [13], [14]. In general, the parameters must convey

information on the source of the sound (i.e., periodic, aperiodic, or mixed) and on the transfer function of the vocal tract. For voiced speech sounds this transfer function can be adequately specified by the first two or three formants, while for unvoiced speech sounds an indication of overall spectral shape is sufficient. Updating such parameters every 5 to 10 ms allows the production of intelligible speech. In fact, the parameters specifying the transfer function of the vocal tract may be quantized along rather coarse scales. The information rate required to transmit these parametric data can be as low as 1000 bits/s, which is far less than the 30 000 bits/s required for ordinary voice transmission over a typical telephone channel [13]. With such crude representations of speech being adequate to preserve intelligibility for listeners with normal hearing, one might expect that the same representations would be sufficient to convey intelligible speech through a cochlear prosthesis. The difficulty is in presenting the parameters in such a way that an implant patient can a) independently perceive each parameter over its full range and b) discriminate a minimum number of steps within this range.

Implant Psychophysics

At least two mechanisms are likely to underlie the perception of pitch in listeners with normal hearing [9], [15]. One is the “place code” reviewed above. The other is “volley code,” based on phase locking among auditory nerve responses for stimulus frequencies below 5 kHz. That is, each neuron of an ensemble of neurons preferentially responds at a particular phase of a sinusoidal stimulus. Even though each neuron does not respond to every period of the stimulus (except at very low stimulus frequencies), the summed ensemble volley of responses that reaches the CNS contains intervals reflecting the frequency of stimulation. A slight jitter in the ability of neurons to phase lock severely limits volley coding as a representation of frequency above 4–5 kHz. In normal hearing both the place of maximal vibration along the basilar membrane and the rate of vibration at that point probably are conveyed to the CNS for stimulus frequencies below about 5 kHz. At higher frequencies the place code may be the sole mechanism for pitch perception.

Both the place and volley codes appear to have at least some salience for multichannel implant patients. For a given electrode site and loudness level, perceived pitch follows

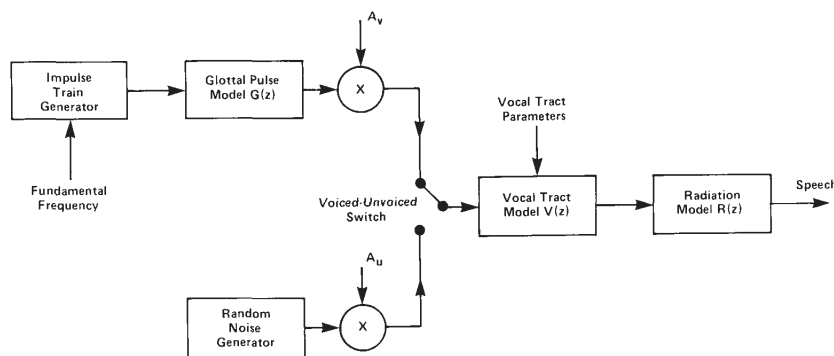

Fig. 3. Source-filter model of speech production. A_v and A_u denote gain factors to control the levels of source outputs. Illustration redrawn from O’Shaughnessy [14].

the frequency of sinusoids, or the rate at which pulses are delivered, up to a "pitch saturation" limit, typically about 300 Hz [16]. Although a few exceptional patients can discriminate different frequencies of stimulation up to 1000-2000 Hz [17], the great majority of patients cannot discriminate frequencies above the 300 Hz limit. As might be expected on the basis of our previous description of normal hearing, distinct tonal sensations can be evoked by varying the site of stimulation along the cochlear spiral. In general, stimulation at the basal end of the cochlea elicits a sharp or high-pitched percept and stimulation at the apical end elicits a dull or low-pitched percept. However, this ranking of pitches is not robust in all patients [16], [18]. In addition, some patients exhibit a nonmonotonic relation between perceived pitch and the position of stimulation along the cochlear spiral. A probable cause for both these deficiencies is poor or patchy nerve survival. Indeed, Pfingst and co-workers have demonstrated a strong correlation between the ability of their test monkeys to rank pitch according to electrode position and the histological picture of nerve survival obtained after the monkeys were sacrificed [19]. In all cases the ability to rank electrodes was severely degraded in regions of poor nerve survival.

Another major dimension along which electrical stimuli are perceived by implant patients is loudness. In general, loudness depends both on the intensity and waveform characteristics of electrical stimuli. Low frequency sinusoids around 100 Hz have the lowest thresholds and greatest dynamic ranges (between threshold and uncomfortably loud percepts) of all stimulus waveforms [16], [18]. The dynamic range for 100 Hz sinusoids can be as large as 40 dB. In contrast, the dynamic ranges for high frequency sinusoids (e.g., 500 Hz and higher) and short-duration pulses (e.g., 200 μ s/phase) are much narrower. A typical range for short-duration pulses, for example, would be 10-15 dB. All of these dynamic ranges for electrically-evoked hearing are substantially lower than the ranges for normal hearing, which are 100 dB or greater for a wide variety of acoustic stimuli.

PROCESSING STRATEGIES

In the remainder of this paper we will explore in some detail the implications of nerve survival for processor design and performance. In this section we will describe two different processing strategies in terms of the output signals they deliver to a multichannel electrode array. One of these strategies implicitly assumes good nerve survival in the implanted ear whereas the other strategy is designed specifically to avoid the deleterious effects of channel interactions in ears with poor nerve survival.

Compressed Analog Processors

A widely-applied processing strategy for multichannel cochlear prostheses is illustrated in Fig. 4. We call it the compressed analog (CA) strategy because the basic functions of the processor are to compress wide-dynamic-range speech input signals onto the narrow dynamic range available for electrical stimulation of the ear, and then to filter the compressed signal into individual frequency bands for presentation to each electrode's sector of the cochlea. Typical waveforms of such a processor are shown in the figure. The top trace in each panel is the input signal, which in this

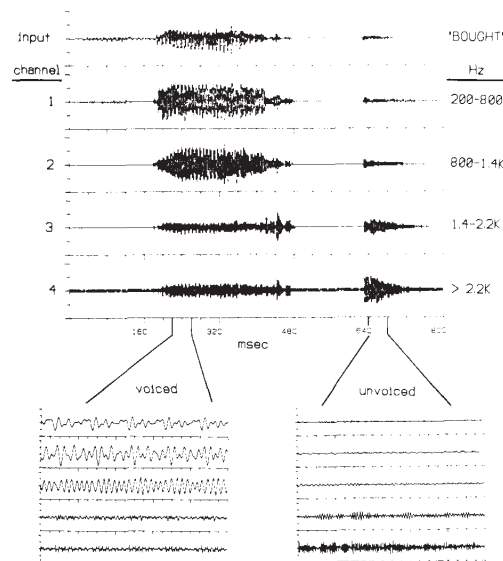

Fig. 4. Waveforms of a compressed analog (CA) processor.

case is the word "BOUGHT." The other waveforms in each panel are the filtered output signals for 4 channels of intracochlear stimulation. The bottom left panel shows an expanded display of waveforms during the initial part of the vowel in BOUGHT, and the bottom right panel shows an expanded display of waveforms during the final "T." The lower panels in Fig. 4 thus exemplify differences in waveforms for voiced and unvoiced intervals of speech.

In the voiced interval the relatively large outputs of channels 1 and 2 reflect the low-frequency formant content of the vowel, and in the unvoiced interval the relatively large outputs of channels 3 and 4 reflect the high-frequency noise content of the "T." Moreover, the clear periodicity in the waveforms of channels 1 and 2 reflects the fundamental frequency of the vowel during the voiced interval, whereas the lack of periodicity in the outputs of all channels reflects the noise-like quality of the "T" during the unvoiced interval. Features represented in this way are perceived to varying degrees by different implant patients. A principal concern is that simultaneous stimulation with continuous waveforms results in summation of the electric fields from the individual electrodes. This summation can exacerbate interactions between channels, especially for patients who require high stimulation levels. Summation of stimuli between channels also depends on the phase relationships among the waveforms. Because these relationships are not controlled in a CA processor, representation of the speech spectrum may be further distorted by continuously changing patterns of channel interaction. Therefore, one might expect that CA processors would work best for patients with low stimulation thresholds and good isolation between channels, i.e., for patients with relatively good nerve survival and electrode placement.

Interleaved Pulses Processors

The problem of channel interactions is addressed in the processor of Fig. 5 through the use of nonsimultaneous

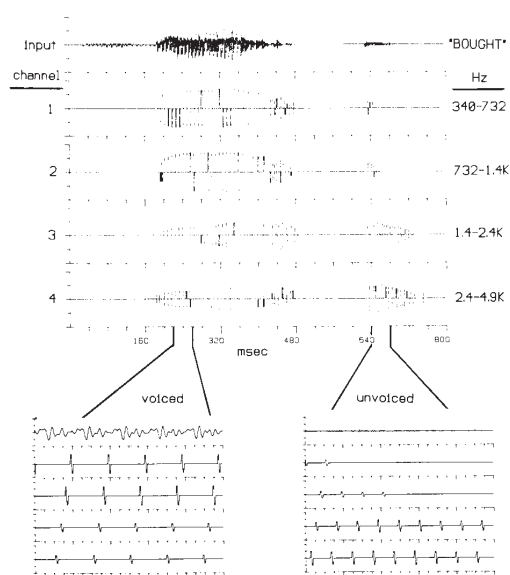

Fig. 5. Waveforms of an interleaved pulses (IP) processor.

stimuli, brief pulses delivered sequentially to the different channels in a stimulation cycle. There is no overlap between the pulses so that direct summation of electric fields produced by different electrodes is avoided. The energies of frequency components in speech are represented by the amplitudes of the pulses, and distinctions between voiced and unvoiced segments of speech are represented by the timing of cycles of stimulation across the electrode array. In this particular processor stimulation cycles are timed to begin in synchrony with the detected fundamental frequency for voiced speech sounds and at a fixed maximum rate (with one stimulation cycle immediately following its predecessor) for unvoiced speech sounds. The timing of stimulation cycles for voiced and unvoiced intervals can be seen in the lower panels of Fig. 5.

Because simultaneous stimulation of channels is avoided in this "interleaved pulses" (IP) processor, one might expect that its use could improve performance for patients with severe channel interactions.

EVALUATION STUDIES

We have studied relative levels of performance with the CA and IP processing strategies in eight implant patients using a broad range of speech tests. All patients had been implanted with the multichannel electrode array developed at the University of California at San Francisco (UCSF) and subsequently manufactured by Storz Instrument Company of St. Louis. This array has eight pairs of bipolar electrodes, with a 2 mm spacing between pairs [6]. In ears with good nerve survival such an array would be expected to allow a high degree of spatial selectivity in the excitation of auditory neurons [7], [8].

From the outset an important aim of the evaluation studies was to compare alternative processing strategies in tests with individual implant patients. In this way we could provide hitherto unrealized controls for differences among

patients in a) electrode placement, b) the pattern of nerve survival in the implanted ear, c) the integrity of the CNS pathways associated with hearing, and d) cognitive skill and language acquisition. In addition, our comparisons of processing strategies with individual patients would share a single type of electrode array and uniformly administered tests.

The first two patients studied were fitted with percutaneous cables and the remaining six with the four-channel transcutaneous transmission system (TTS) of the UCSF/Storz prosthesis [20]. Use of the cable allows direct access to all 16 electrode contacts in the array (usually configured as eight bipolar pairs) and direct control over the current or voltage waveforms of the stimuli. In contrast, alternating bipolar electrode pairs are assigned to the four channels of the TTS, and the current and voltage waveforms are complex functions of the nonlinear impedances of the electrodes and the limited frequency response of each TTS channel.

Because the cable allowed a much greater degree of stimulus control, many different processing strategies were evaluated in the studies with the first two patients (LP and MH). The performance of each strategy was measured with tests of vowel and consonant identification. The vowel test included the tokens "BOAT," "BEET," "BOUGHT," "BIT," and "BOOT," and the consonant test included the non-sense tokens "ATA," "ADA," "AKA," "ASA," "AZA," "ANA," "ALA," and "ATHA." The vowel tokens were selected to measure the ability to perceive relatively large differences in the formant frequencies of these particular vowels, and the consonant tokens were selected to measure the ability to distinguish the nonlabial consonants that have the greatest frequency of occurrence in spoken English [21]. These vowel and consonant matrix tests were administered as forced choices among the five or eight tokens, respectively. The minimum number of presentations of each token in a single test was five or three, respectively. Retests after various intervals confirmed the reliability of such brief tests as guides for processor tailoring.

Among the processing strategies evaluated with these first two patients, the IP approach achieved the best results. To assess further the performance of this strategy vis-à-vis the standard CA strategy of the UCSF/Storz prosthesis, an extensive series of standard tests was designed for the remaining six patients (all of whom were fitted with the TTS). In addition to the vowel and consonant identification tests just outlined this series included: all subtests of the Minimal Auditory Capabilities (MAC) battery [22]; the Diagnostic Discrimination Test (DDT) of consonant confusions [23]; connected discourse tracking (verbatim repetition by the patient of a text read by the investigator) with and without the prosthesis [24], [25]; and the Iowa test of medial consonant identification with lipreading cues [26]. In this paper we will briefly review the results from the vowel and consonant identification tests for all patients, and from the MAC and Iowa tests for the six patients fitted with the TTS. Results for the various patients will be compared for each individual test. Because of the highly varied nature of the MAC subtests, any attempt to analyze performance across tests would necessarily involve highly arbitrary assumptions about the relative weights of the subtest results. Detailed reports of the evaluation studies are available elsewhere [27]-[30].

Patient LP

The first patient (LP) had a most discouraging picture of psychophysical performance. He had extremely severe channel interactions and high thresholds for bipolar electrical stimulation. His case was further complicated by extraordinarily narrow dynamic ranges and lability of thresholds and loudness levels both within and between testing sessions. LP's psychophysical findings of severe channel interactions, high thresholds, and narrow dynamic ranges were all consistent with a picture of very poor survival of neurons in his implanted ear [12], [19], [29], [31]-[33].

As might be expected, LP received no benefit from the CA processor used in the standard UCSF prosthesis. Indeed, he refused to describe any of the percepts produced with this processor as speechlike.

The first application of a 6-channel IP processor immediately moved LP into the speech mode of auditory perception [27], [29]. Of the 11 vowel and consonant tokens initially presented to LP using the IP processor, 7 were spontaneously recognized as the correct words or syllables. Although his performance declined when the number of channels was reduced from 6 to 4, formal tests of vowel identification indicated that LP could perform at a level significantly above chance ($p < 0.01$) even with a reduced 4-channel version of the IP processor [27]. A medical complication required surgical removal of LP's implant, ending our study of him with these very encouraging preliminary results.

Patient MH

With the second patient we were able to evaluate differences in processor performance in much greater detail. This patient also had psychophysical manifestations of poor nerve survival [28], [29]. The results presented in Fig. 6 show her levels of performance in tests of vowel and consonant identification. The diagonally hatched bars show her performance with lipreading, and the cross hatched bars without. The chance levels of performance are indicated by the horizontal lines in each panel. Different processors are represented by different sets of bars. The characteristics of each processor are indicated in the labels at the bottom. For example, the leftmost set of bars shows the scores for a 4-channel CA processor. The remaining sets of bars show the scores for four variations of IP processors. These variations were produced by manipulating a) the number of stimulation channels and b) the way in which the beginnings of stimulus sequences were timed. In one approach stimulation cycles were timed to start in synchrony with the fundamental frequency for voiced speech sounds and at randomly-varied intervals during unvoiced speech sounds. This constituted explicit coding of fundamental frequency and voiced/unvoiced distinctions. In the other approach, stimulation cycles were timed to follow each other as rapidly as possible, providing no explicit coding of voicing information. In all, the results shown in Fig. 6 allow direct comparisons of a) a 4-channel CA processor versus a 4-channel IP processor; b) 4- versus 6-channel IP processors; and c) IP processors with and without explicit coding of voicing information. The comparisons indicate that:

- 1) Performance is markedly improved when a 4-channel IP processor is used instead of a 4-channel CA processor;

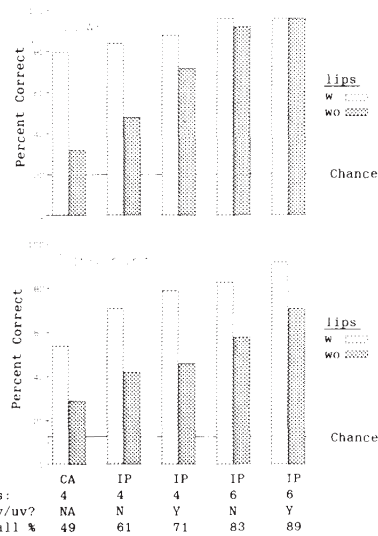

Fig. 6. Results of vowel and consonant identification tests for patient MH. Diagonally-hatched bars indicate results obtained with lipreading and cross-hatched bars indicate results obtained without lipreading. The table at the bottom of the figure indicates the type of processor used (abbreviations are CA for "compressed analog" and IP for "interleaved pulses"); the number of stimulation channels; whether voicing information was explicitly coded for the IP processors; and the overall percent-correct scores from the four test conditions for each processor. The horizontal line in each panel shows the level of chance performance for that test. All of the scores are significantly above chance at the $p < 0.01$ level, except those for the compressed analog processor tests without lipreading.

- 2) Scores are *much* higher in all categories except vowel identification with lipreading (where scores are about the same) when a 6-channel IP processor is used instead of a 4-channel IP processor; and
- 3) Explicit coding of voicing information improves the performance of IP processors, particularly in the categories of vowel identification without lipreading (4-channel processor), consonant identification without lipreading (6-channel processor), and consonant identification with lipreading (both processors).

Good test/retest reliability was thoroughly demonstrated for MH. When retested with a processor that had produced low scores on a previous occasion, MH always would obtain low scores again, and when repeating a test with a processor that earlier had performed well she always would repeat her high scores. The standard deviation of overall percent correct scores from seven repeated trials of the last (rightmost) processor shown in Fig. 6, for example, was slightly less than three percent. All scores presented in Fig. 6 are significantly above chance ($p < 0.01$) except for those of the two hearing-alone conditions for the CA processor.

Patients Fitted with the Transcutaneous Transmission System (TTS)

The studies with the two percutaneous cable patients demonstrated that a) different processing strategies can produce widely different outcomes for individual patients

and b) IP processors are far superior to the tested alternative processors for at least two patients with psychophysical signs of poor nerve survival. With these observations in mind, we were most interested in comparing the IP and CA strategies in extensive tests with a larger population of patients. We wondered, for example, how the IP processor would perform for successful users of a CA processor, and whether the potential advantages of the IP processors could be realized in patients with four or fewer channels of stimulation.

Six patients fitted with the 4-channel UCSF/Storz TTS participated in the follow-up studies. Each patient was studied for a one-week period in which a) basic psychophysical measures were obtained on thresholds and dynamic ranges for pulsatile stimuli, b) a variety of IP processors (with different choices of processor parameters) was evaluated with tests of vowel and consonant identification, and c) the best of these IP processors was evaluated further using a broad spectrum of speech tests. The speech tests included all subtests of the Minimal Auditory Capabilities (MAC) battery [22]; the Diagnostic Discrimination Test (DDT) of consonant confusions [23]; connected discourse tracking [24], [25]; and the Iowa test of medial consonant identification with lipreading cues [26]. Comparison data for the CA processor were obtained from MAC, tracking, and DDT tests administered on a previous occasion (within the 3 months preceding the IP tests) as part of the clinical trials of the UCSF/Storz prosthesis. Repeat tests with the CA processor were administered in all cases where a significant difference in scores was found between the two types of processor. Finally, the vowel and consonant identification tests and the Iowa test were administered by us for both processors.

It is important to note several factors that favored the CA processor in comparisons of processor performance. First, all six patients entered our studies with substantial experience using the CA processor. We expected that the learning effects of such experience would strongly favor the CA processor in the comparisons (see [34] and [35] for further discussions on this point). In a typical case, experience with the CA processor would approximate one year of daily use, while experience with the real-time implementation of the IP processor would be between 15 and 30 minutes before formal testing. Therefore, the information provided by an IP processor would have to be immediately accessible to the patient in order for the results to be at all comparable to those obtained with the CA processor.

An additional factor weighing against the IP processor in these performance comparisons was the use of the 4-channel TTS. The principal limitations of that system for IP processors are a) inadequate levels of voltage compliance for stimulation with short-duration pulses, b) the small number of channels, and c) lack of current control in the stimulus waveforms. Half of the patients in this study were further limited by having even fewer than four functional channels available for stimulation. The loss of one or two channels in each of these cases has been attributed to fluid or particulate contamination admitted to the connector assembly of the implanted portion of the TTS during surgery [20]. Although the problem of contamination has since been solved by modifying the surgical procedure, most of these six patients were implanted before the problem was evident and before these revisions had been made.

Extensive evaluation (with patient MH; see [28], [29]) of

variations in performance with parametric manipulations among IP processors suggested the following five criteria for fitting such designs, in approximate order of decreasing importance:

- 1) Total number of channels (large increases in performance are found when the number of channels is increased from 2 to 4 and from 4 to 6);
- 2) Number of channels updated per stimulation cycle, if fewer than the total number of available channels (performance in tests of consonant identification declines precipitously if the number of updated channels falls below 4);
- 3) Total duration of each stimulation cycle (performance gets better as duration is decreased, and is markedly better when the duration is less than 4–5 ms);
- 4) Time between sequential pulses (performance improves as the time between pulses is increased, up to the point at which the total duration of the stimulation cycle begins to exceed 4–5 ms); and
- 5) Explicit coding of voicing information (performance is better with explicit coding of voicing information, and the percepts elicited with processors that use such coding generally are described as more natural and speechlike).

Notice that the small number of channels and limited voltage compliance of the TTS place severe restrictions on meeting criteria 1)–4) above. Also, the lack of current control introduces distortions in stimulus waveforms that may require greater separation of pulses in order to avoid channel interactions.

The parameters selected for the IP processors of these six TTS patients are presented in Table 1. The best fulfill-

Table 1 Parameters of Real-Time IP Processors

Patient	Channels	Pulsewidths/Phase (ms)	Pulse Sep. (ms)	Cycle Time (ms)
MC1	3	0.5	0.5	4.5
HE	4	0.5	0.5	6.0
JM	3	1.0	0.1	6.3
RC	2	0.5	0.1	2.2
ET	4	1.0 1.0 0.5 0.5	0.1	6.4
MC2	4	0.3 0.7 0.3 0.3	0.5	5.2

All six processors used symmetric biphasic pulses with positive phase leading and with the channels stimulated in base-to-apex order. Stimulation cycles were presented at the fundamental frequency for voiced intervals and at maximum rate (period equal to cycle time) during unvoiced intervals.

ments of the five criteria were obtained for patients HE and MC2. Each had the use of all four stimulation channels and the time between sequential pulses was a relatively long 0.5 ms for both patients. In addition, the stimulation cycle time for MC2 was almost within the 5.0 ms criterion for this parameter.

In contrast, relatively poor sets of parameters had to be used for the remaining patients. Patients MC1 and JM had only three usable channels and patient RC only two. The cycle times remained excessive for patients JM and ET, even with the times between pulses compromised down to only 0.1 ms.

The results of processor comparisons are presented in Figs. 7-11. Fig. 7 shows performance levels for the tests of

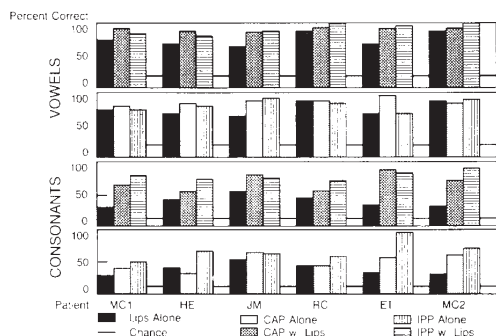

Fig. 7. Results of vowel and consonant identification tests for six patients fitted with the 4-channel UCSF/Storz transcatheter transmission system. All of these scores are significantly above chance at the $p < 0.01$ level, except for some scores for the consonant tests with lipreading alone.

vowel and consonant identification. Solid black bars represent the scores for lipreading alone, dotted bars for the CA processor alone, and cross-hatched bars for the CA processor with lipreading. Vertically-lined bars represent the scores for the IP processor alone and horizontally-lined bars for the IP processor with lipreading. Chance levels of performance are indicated by the horizontal lines in each panel and, as is the case in subsequent figures, any results that do not significantly exceed chance are noted in the figure captions.

Performance in the tests of vowel identification is quite high for both processors. All patients have scores of 80 percent correct or better for both processors with lipreading and 68 percent or better without lipreading. The means of the results for the two processors are not significantly different for either condition.

In contrast to the apparent equivalence of processors for the vowel test, the scores for the consonant test without lipreading are significantly higher for the IP processor (at the $p < 0.05$ level, paired t test). All patients except JM obtained higher scores using the IP processor for this condition. The difference between the means for the "with lipreading" condition is not significant. Analysis of specific confusions across different processing strategies and different patients is under way and will be presented elsewhere.

An indication of superior consonant recognition with the IP processor is also seen in the results for the lowa test of medial consonant identification with lipreading cues. These results are presented in Fig. 8. Every patient except MC2 has substantially higher scores with the IP processor. However, the difference in the means of the results for the two processors is not statistically significant. It is important to note

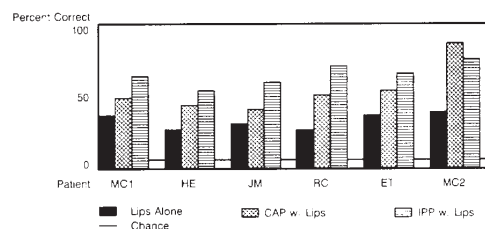

Fig. 8. Results from the lowa test of medial consonant identification with lipreading cues. The patients are those described in the caption of Fig. 7. All of these results are significantly above chance at the $p < 0.01$ level.

that our procedure for administering this test was designed to confer any benefits of learning on the CA processor. The order of testing was to measure performance first with the IP processor plus lipreading, then with lipreading alone, and finally with the CA processor plus lipreading.

In addition to paired t tests, a Wilcoxon test for significant improvement across the six patients was applied to each subtest of our combined battery. Only two tests emerged from the Wilcoxon analysis as indicating significant improvement with the use of one processor over the other. Both the RTI consonant confusion test without lipreading and the lowa test of medial consonant identification with lipreading indicated better performance with the IP processor at a significance level of $p < 0.05$ (Wilcoxon T+ = 20, $p = 0.03$).

The remaining results presented in Figs. 9-11 are those from the MAC battery. Results from the subtests of prosodic perception (timing of syllable boundaries, voice fundamental frequency, and word stress) are shown in Fig. 9.

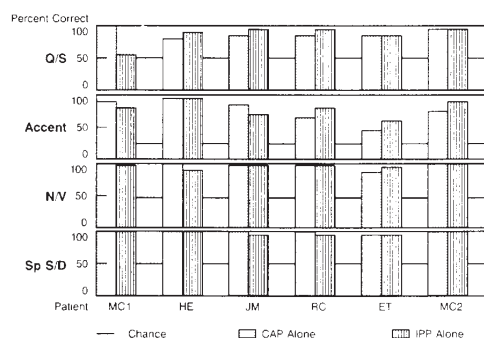

Fig. 9. Results from subtests of the Minimal Auditory Capabilities (MAC) battery designed to evaluate perception of prosodic elements in speech. Abbreviations for the subtests are Q/S for Question/Statement; N/V for Noise/Voice; and Sp S/D for Spondee Same/Different. The patients are those described in the caption of Fig. 7. All these results are significantly above chance at the $p < 0.01$ level except MC1's score for the Q/S test with the IP processor and ET's score for the Accent test with the CA processor.

These results demonstrate that, in general, these subtests are too easy for the patients and processors under study. The scores for the noise/voice (N/V) and spondee same/different (Sp S/D) tests are very high for all patients and for both processors. (Spondees are two syllable words like "cowboy" with equal emphasis on the syllables.) The accent

test is a more sensitive indicator of performance. Scores for this test show clear differences among patients, but relatively modest differences between processors. Three patients did moderately better with the IP processor on this test (RC, ET, and MC2), and two patients did moderately better with the CA processor (MC1 and JM). Finally, for the Question/Statement (Q/S) test one patient did much better with the CA processor (MC1), three patients did somewhat better with the IP processor (HE, JM, and RC), and two patients obtained identical scores with the two processors (ET and MC2). None of the differences in the means of the results for the two processors is statistically significant among the prosodic subtests of the MAC battery.

Results from the phoneme and word subtests of the MAC battery also demonstrate a general equivalence of the processors for the conditions of our study. These results are presented in Fig. 10. Again, none of the differences in the

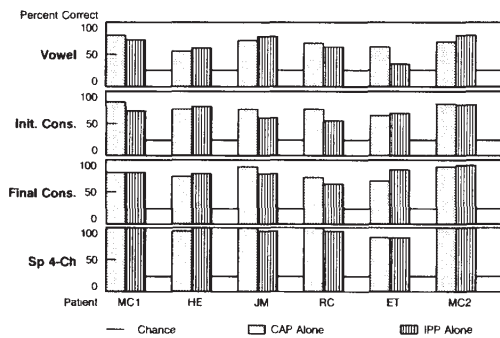

Fig. 10. Results from subtests of the Minimal Auditory Capabilities (MAC) battery designed to evaluate perception of phonemes and words in speech. Abbreviations for the subtests are Init. Cons. for Initial Consonant; Final Cons. for Final Consonant; and Sp 4-Ch for Four-Choice Spondee. The patients are those described in the caption of Fig. 7. All these results are significantly above chance at the $p < 0.01$ level except ET's score for the Vowel test with the IP processor.

means of the results for the two processors is statistically significant. Patients HE and MC2 have somewhat higher or equivalent scores on all four tests (including vowel, initial consonant, final consonant, and four-choice spondee) with the IP processor, and patients MC1 and RC have somewhat higher or equivalent scores with the CA processor.

Finally, results from the subtests of open-set recognition are shown in Fig. 11. Once again, none of the differences in the means of the results for the two processors is statistically significant. Patient MC2, however, has higher scores for the IP processor for all four subtests of spondee recognition (Sp), recognition of monosyllabic words (NU6), recognition of CID sentences (CID), and recognition of words in context (WIC). In addition, patient HE has much higher scores with the IP processor for the tests of spondee recognition and of words in context. On the other hand, patient RC has higher scores with the CA processor on every open-set test, and patients MC1 and ET show generally superior performance with the CA processor for those tests.

Wilcoxon tests do not identify any of the MAC subtests as indicating significant improvement for one processor over the other across the six patients. As discussed above,

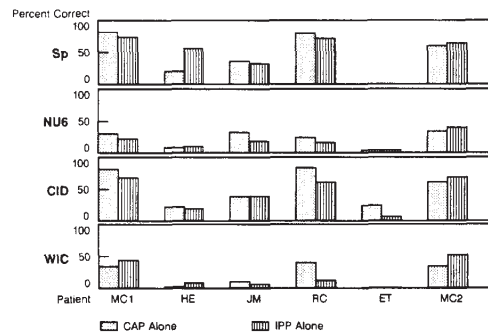

Fig. 11. Results from subtests of the Minimal Auditory Capabilities (MAC) battery designed to measure open-set recognition of speech. Abbreviations for the subtests are Sp for Spondee recognition; NU6 for recognition of monosyllabic words from Northwestern University list six; CID for recognition of everyday sentences from lists prepared at the Central Institute for the Deaf; and WIC for recognition of Words in Context. The patients are those described in the caption of Fig. 7.

differences among the subtests would make any analysis across them highly arbitrary.

Summary of Results

In the studies with the two percutaneous cable patients, each of whom had a bleak psychophysical picture consistent with poor nerve survival, the IP strategy produced much better results than the CA strategy. We believe this improved performance with the IP processor is attributable in part to the sizable reduction in channel interactions afforded by the use of nonsimultaneous stimuli. The studies with the cable patients further demonstrated a very strong correspondence between number of stimulation channels and performance. In the studies with the six patients fitted with the TTS, the IP and CA processors were compared under conditions of substantial experience with the CA processor, generally high levels of performance with the CA processor, and severe restrictions imposed by the TTS for implementing optimized versions of the IP processor. Despite these limitations, two patients in this second series *immediately* had better performance with the IP processor (patients HE and MC2) and three had similar or slightly inferior levels of performance with this processor (patients MC1, JM and ET). Only one patient (RC) had clearly superior performance with the CA processor. This patient also happened to have the highest level of performance among the six studied patients with the CA processor and, with only two functioning channels, afforded the poorest fulfillment of our fitting criteria for the IP processor.

These results suggest that a) most patients are likely to obtain at least equivalent results if an IP processor is used instead of a CA processor; b) patients with psychophysical signs of poor nerve survival are likely to obtain better results with an IP processor; and c) use of a TTS designed to support an IP processor (e.g., a TTS with eight channels of current-controlled outputs) is likely to produce results that are better than those obtained with the limited TTS of the present studies.

DISCUSSION

A key finding of the studies reviewed in this paper is that substantial gains in speech perception can be made by selecting an appropriate processing strategy for each patient. In our two series of patients, RC obtained clearly superior results with the CA processing strategy while LP and MH obtained clearly superior results with the IP processing strategy. These results demonstrate that access to a variety of alternative strategies may be required for optimizing the outcomes across a population of patients.

The patient who obtained superior results with the CA processor (RC) had only two functional channels of intracochlear stimulation. This number of channels is certainly too few for even a gross representation of the speech spectrum with an IP processor. The relatively poor performance of the IP processor therefore could be attributed to a poor fulfillment of its fitting criteria.

An alternative explanation for the superior performance of the CA processor is that RC made especially good use of the information present in the compressed analog waveforms. Indeed, the impressive results obtained with RC (two channels), MC1 (three channels), certain patients in the Vienna series (one channel; see [17]), and certain patients in the Symbion series (four monopolar channels with relatively poor isolation; see [36]) support the hypothesis that the major bearer of information in CA processors is the waveform itself. Although results from studies conducted at UCSF demonstrate that additional information can be provided with four channels of stimulation using the UCSF electrode array [37]–[39], this additional information obviously is not required for excellent performance in some patients. Most likely, the best results are obtained for patients who have the greatest access to information in the CA waveform(s). These patients might include those with exceptional abilities to discriminate a) frequencies up through the range of the first formant of speech [17], [36], [40]; b) rapid temporal variations in the envelopes of speech and speechlike stimuli [41]; and c) subtle waveshape changes produced by the addition of frequency components beyond the first formant [42], [43].

If this second interpretation is pertinent to RC's case, then patients with such special abilities might be best served with a CA processor. Optimal implementations of such a processor would provide any additional information the patient might be able to utilize in multiple channels of stimulation. The maximum number of useful channels is likely to be limited, however, by the severe interactions that can occur between closely spaced electrodes when simultaneous stimuli are used.

In contrast, patients with a psychophysical picture consistent with poor nerve survival (i.e., severe channel interactions, high thresholds, narrow dynamic ranges, and perhaps limited abilities to discriminate frequencies and other stimulus attributes) are likely to receive greater benefit from an IP processor. For two such patients in our initial series large increases in performance were obtained when the number of stimulus channels was increased from 2 to 4 and from 4 to 6. Paradoxically, then, multichannel implants may provide relatively greater benefits to patients with signs of poor nerve survival than to patients without these signs.

To summarize the comparisons made above, Table 2 lists characteristics of the CA and IP processing strategies. Briefly, the CA strategy may be superior for patients with

Table 2 Characteristics of Processors*

Analog	Pulsatile
Continuous waveforms, presented simultaneously	Nonsimultaneous pulses
Severe interactions between channels for patients with poor nerve survival	Improved channel isolation, especially for patients with poor nerve survival
<i>In some patients, continuous waveforms can provide good temporal and frequency information (F_0, voiced/unvoiced distinctions, F_1, possibly F_2)</i>	Limited transmission of temporal and frequency information (F_0 , voiced/unvoiced distinctions)

*Symbols used in this table are F_0 for the fundamental frequency of voiced-speech sounds, F_1 for the first formant frequency of speech, and F_2 for the second formant frequency of speech.

good nerve survival because such patients may perceive substantial temporal and frequency information in analog waveforms and because the lower stimulus intensities required for these patients, along with survival of neural elements over the active electrodes, can greatly minimize channel interactions produced by simultaneous stimulation. On the other hand, the IP strategy may be superior for patients with poor nerve survival because isolation between channels for such patients is tremendously improved with the use of nonsimultaneous stimuli.

Finally, we note that these comparisons between processors suggest possibilities for further improvements in performance. One such improvement might be made by combining the best features of the CA and IP approaches in "hybrid" strategies. For a good nerve survival case, for example, the main benefits of the CA strategy might be realized with a single channel of stimulation. This would leave the remaining channels for IP representation of frequency components in speech above the first formant. The excellent results obtained in the present studies with all eight patients using the IP processor (especially patients HE, MC2, and MC1) indicate that interleaved stimuli are likely to enhance speech representation even for patients with good nerve survival (presumably through further reduction of interactions between adjacent channels). The combined use of the CA and IP strategies therefore might confer in an optimal way the benefits of waveform discrimination and multichannel stimulation to fortunate patients with good nerve survival. Similarly, for cases in which nerve survival is patchy, psychophysical or electrophysiological tests might be conducted to identify areas of good survival. A bipolar pair of electrodes adjacent to one of these areas could be selected for compressed analog stimulation. This electrode channel would have low threshold and suprathreshold stimulus levels relative to electrodes adjacent to poor survival areas. Such low levels might allow the remaining electrode channels to receive IP stimuli with only minor channel interactions.

Potential applications of hybrid processors, along with the choices posed by the existing CA and IP strategies, emphasize the need for flexibility in the fitting of speech processors to individual patients. We believe further significant advances in the development of speech processors for cochlear prostheses will result from a) an improved understanding of the electrode-nerve interface, especially

as it relates to the pattern of nerve survival, and b) design and application of better psychophysical and electrophysiological tests to infer the pattern of survival in the implanted ear.

CONCLUSIONS

The major conclusions from the studies reviewed in this paper are the following:

- 1) Different processing strategies can produce widely different outcomes for individual implant patients;
- 2) Interleaved pulses (IP) processors are far superior to the tested alternative processors for at least two patients with psychophysical signs of poor nerve survival;
- 3) The performance of IP processors strongly depends on the selection of processor parameters;
- 4) Processors other than the IP processors can be superior for patients with psychophysical signs of good nerve survival and for patients who cannot be fit with an optimized IP processor;
- 5) One such processor is the compressed analog (CA) processor of the present UCSF/Storz cochlear prosthesis; and
- 6) Substantial gains in speech understanding can be made by a) selecting the best type of speech processor for each patient and b) using implanted and external hardware capable of supporting a wide range of different processing strategies.

ACKNOWLEDGMENT

The authors wish to thank the patients who participated in the evaluation studies for their dedicated effort and pioneering spirit. The authors are pleased to acknowledge the important scientific contributions of L. J. Dent, J. C. Farmer, Jr., F. T. Hambrecht, P. D. Kenan, D. K. Kessler, G. E. Loeb, M. M. Merzenich, R. A. Schindler, R. V. Shannon, M. W. Skinner, L. Vurek, B. A. Weber, and M. W. White.

REFERENCES

- [1] J. B. Millar, Y. C. Tong, and G. M. Clark, "Speech processing for cochlear implant prostheses," *J. Speech Hear. Res.*, vol. 27, pp. 280-296, 1984.
- [2] B. C. J. Moore, "Speech coding for cochlear implants," in *Cochlear Implants*, R. F. Gray, Ed. San Diego, CA: College-Hill Press, 1985, pp. 163-179.
- [3] C. W. Parkins, "Cochlear prostheses," in *Neurobiology of Hearing: The Cochlea*, R. A. Altschuler, D. W. Hoffman, and R. P. Bobbin, Eds. New York, NY: Raven Press, 1986, pp. 455-473.
- [4] B. E. Pfingst, "Stimulation and encoding strategies for cochlear prostheses," *Otolaryngol. Clin. N. Amer.*, vol. 19, pp. 219-235, 1986.
- [5] R. Hinojosa and M. Marion, "Histopathology of profound sensorineural deafness," *Ann. N.Y. Acad. Sci.*, vol. 405, pp. 459-484, 1983.
- [6] G. E. Loeb et al., "Design and fabrication of an experimental cochlear prosthesis," *Med. & Biol. Eng. & Comput.*, vol. 21, pp. 241-254, 1983.
- [7] M. M. Merzenich and M. W. White, "Cochlear implant: The interface problem," in *Functional Electrical Stimulation: Applications in Neural Prostheses*, F. T. Hambrecht and J. B. Reswick, Eds. New York, NY: Marcel Dekker, 1977, pp. 321-346.
- [8] C. van den Honert and P. H. Stypulkowski, "Single fiber mapping of spatial excitation patterns in the electrically stimulated auditory nerve," *Hearing Res.*, vol. 29, pp. 195-206, 1987.
- [9] J. O. Pickles, *An Introduction to the Physiology of Hearing*. London, England: Academic Press, 1982, ch. 9, pp. 275-277.
- [10] R. V. Shannon, "Multichannel electrical stimulation of the auditory nerve in man. II. Channel interaction," *Hearing Res.*, vol. 12, pp. 1-16, 1983.
- [11] ——"Loudness summation as a measure of channel interactions in a cochlear prosthesis," in *Cochlear Implants*, R. A. Schindler and M. M. Merzenich, Eds. New York, NY: Raven Press, 1985, pp. 323-334.
- [12] M. W. White, M. M. Merzenich, and J. N. Gardi, "Multichannel cochlear implants: Channel interactions and processor design," *Arch. Otolaryngol.*, vol. 110, pp. 493-501, 1984.
- [13] J. L. Flanagan, *Speech Analysis, Synthesis and Perception*, Second Edition. Berlin, Germany: Springer-Verlag, 1972.
- [14] D. O'Shaughnessy, *Speech Communication: Human and Machine*. Reading, MA: Addison-Wesley, 1987.
- [15] B. C. J. Moore, *An Introduction to the Psychology of Hearing*. London, England: Academic Press, 1982, ch. 4, pp. 115-140.
- [16] B. E. Pfingst, "Psychophysical data from cochlear implants: Relevance to strategies for rehabilitation," *Seminars in Hearing*, vol. 6, pp. 7-21, 1985.
- [17] I. J. Hochmair-Desoyer and K. Burian, "Reimplantation of a molded scala tympani electrode: Impact on psychophysical and speech discrimination abilities," *Ann. Otol. Rhinol. Laryngol.*, vol. 94, pp. 65-70, 1985.
- [18] R. V. Shannon, "Multichannel electrical stimulation of the auditory nerve in man. I. Basic psychophysics," *Hearing Res.*, vol. 11, pp. 157-189, 1983.
- [19] B. E. Pfingst, I. Glass, F. A. Spelman, and D. Sutton, "Psychophysical studies of cochlear implants in monkeys: Clinical implication," in *Cochlear Implants*, R. A. Schindler and M. M. Merzenich, Eds. New York, NY: Raven Press, 1985, pp. 305-321.
- [20] R. A. Schindler, D. K. Kessler, S. J. Rebscher, J. L. Yanda, and R. K. Jackler, "The UCSF/Storz multichannel cochlear implant: Patient results," *Laryngoscope*, vol. 96, pp. 597-603, 1986.
- [21] E. D. Schubert, "Some limitations on speech coding for implants," in *Cochlear Implants*, R. A. Schindler and M. M. Merzenich, Eds. New York, NY: Raven Press, 1985, pp. 269-276.
- [22] E. Owens, D. K. Kessler, M. Raggio, and E. D. Schubert, "Analysis and revision of the Minimal Auditory Capabilities (MAC) battery," *Ear Hear.*, vol. 6, pp. 280-287, 1985.
- [23] C. B. Grether, "Psychoacoustic assessment of speech communication systems: The diagnostic discrimination test," Project Themis. Air Force Office of Scientific Research, Contract F44620-69-C-0033, Sept. 22, 1970.
- [24] C. L. De Filippo and B. L. Scott, "A method for training and evaluating the reception of ongoing speech," *J. Acoust. Soc. Am.*, vol. 63, pp. 1186-1192, 1978.
- [25] E. Owens and M. Raggio, "The UCSF tracking procedure for evaluation and training of speech reception by hearing-impaired adults," *J. Speech & Hear. Disorders*, vol. 52, pp. 120-128, 1987.
- [26] R. S. Tyler, J. P. Preece, and M. W. Lowder, "The Iowa cochlear-implant test battery," Laboratory Report, University of Iowa at Iowa City, Department of Otolaryngology—Head and Neck Surgery, 1983.
- [27] B. S. Wilson, C. C. Finley, and D. T. Lawson, "Speech processors for auditory prostheses," *Seventh Quarterly Progress Report*, NIH project NO1-NS-3-2356. Bethesda, MD: Neural Prosthesis Program, National Institutes of Health, 1985.
- [28] ——"Speech processors for auditory prostheses," *Second Quarterly Progress Report*, NIH project NO1-NS-5-2396. Bethesda, MD: Neural Prosthesis Program, National Institutes of Health, 1986.
- [29] B. S. Wilson et al., "Comparative studies of speech processing strategies for cochlear implants," *Laryngoscope*, in press.
- [30] B. S. Wilson et al., "Direct comparisons of analog and pulsatile coding strategies with six cochlear implant patients," in prep.
- [31] M. M. Merzenich, P. Leake-Jones, M. Vivion, M. White, and M. Silverman, "Development of multichannel electrodes for an auditory prosthesis," *Fourth Quarterly Progress Report*, NIH project NO1-NS-7-2367. Bethesda, MD: Neural Prosthesis Program, National Institutes of Health, 1978.

- [32] J. N. Gardi, "Human brain stem and middle latency responses to electrical stimulation: Preliminary observations," in *Cochlear Implants*, R. A. Schindler and M. M. Merzenich, Eds. New York, NY: Raven Press, 1985, pp. 351-363.
- [33] B. E. Pfingst and D. Sutton, "Relation of cochlear implant function to histopathology in monkeys," *Ann. N.Y. Acad. Sci.*, vol. 405, pp. 224-239, 1983.
- [34] R. S. Tyler, J. P. Preece, C. R. Lansing, S. R. Otto, and B. J. Gantz, "Previous experience as a confounding factor in comparing cochlear-implant processing schemes," *J. Speech Hear. Res.*, vol. 29, pp. 282-287, 1986.
- [35] R. C. Dowell, P. M. Seligman, P. J. Blamey, and G. M. Clark, "Evaluation of a two-formant speech-processing strategy for a multichannel cochlear prosthesis," *Ann. Otol. Rhinol. Laryngol.*, vol. 96 (suppl. 128), pp. 132-134, 1987.
- [36] D. K. Eddington, "Speech recognition in deaf subjects with multichannel intracochlear electrodes," *Ann. N.Y. Acad. Sci.*, vol. 405, pp. 241-258, 1983.
- [37] M. T. Ochs, M. W. White, M. M. Merzenich, and E. D. Schubert, "Speech recognition in single- and multichannel cochlear implants," *J. Acoust. Soc. Am.*, vol. 77 (suppl. 1), p. S81, 1985.
- [38] M. White, M. Ochs, M. Raggio, D. Morledge, and M. Merzenich, "Formant discrimination in a multichannel cochlear prosthesis," *J. Acoust. Soc. Am.*, vol. 77 (suppl. 1), p. S81, 1985.
- [39] R. A. Schindler, D. K. Kessler, S. J. Rebscher, R. K. Jackler, and M. M. Merzenich, "Surgical considerations and hearing results with the UCSF/Storz cochlear implant," *Laryngoscope*, vol. 97, pp. 50-56, 1987.
- [40] M. W. White, "Formant frequency discrimination and recognition in subjects implanted with intracochlear stimulating electrodes," *Ann. N.Y. Acad. Sci.*, vol. 405, pp. 348-359, 1983.
- [41] I. J. Hochmair-Desoyer, E. S. Hochmair, and H. K. Stiglbauer, "Psychoacoustic temporal processing and speech understanding in cochlear implant patients," in *Cochlear Implants*, R. A. Schindler and M. M. Merzenich, Eds. New York, NY: Raven Press, 1985, pp. 291-304.
- [42] R. A. Dobie and N. Dillier, "Some aspects of temporal coding for single-channel electrical stimulation of the cochlea," *Hearing Res.*, vol. 18, pp. 41-55, 1985.
- [43] E. S. Hochmair and I. J. Hochmair-Desoyer, "Aspects of sound signal processing using the Vienna intra- and extracochlear implants," in *Cochlear Implants*, R. A. Schindler and M. M. Merzenich, Eds. New York, NY: Raven Press, 1985, pp. 101-110.
- [44] M. Lawrence, "Factors in the continuing development of auditory prostheses," in *Controversies in Otolaryngology*, J. B. Snow, Ed. Philadelphia, PA: W. B. Saunders, 1980, pp. 433-442.



Blake S. Wilson (Member, IEEE) received the B.S. degree in electrical engineering from Duke University, Durham, NC, in 1974.

Since 1974 he has held several positions at the Research Triangle Institute (RTI), including Research Engineer (1974-1978); Senior Research Engineer (1978-date); Senior Research Scientist (1979-date); and Head, Neuroscience Program Office (1983-date). He also has been an Adjunct Assistant Professor of Otolaryngology at the

Duke University Medical Center since 1984. During his tenure at RTI, he has directed twelve projects as principal investigator. Most of these were in the areas of cochlear implants and effects of non-ionizing radiation on brain activity. He now directs a large project supported by the Neural Prosthesis Program at NIH, titled "Speech Processors for Auditory Prostheses."



Charles C. Finley (Member, IEEE) was born in Florence, AL, in 1949. He received the B.S. degree (co-operative student program) in electrical engineering from Georgia Institute of Technology, Atlanta, in 1972, and the Ph.D. degree in neurobiology from the University of North Carolina at Chapel Hill, in 1983. His doctoral research was concerned with the functional properties of the peripheral efferent vestibular system in behaving gerbils.

Generally interested in sensory and attention mechanisms, he has pursued research in vestibular and auditory processing of animal models, as well as in clinical populations of hyperactive and autistic children. Presently he is a Senior Research Scientist with the Neuroscience Program Office of Research Triangle Institute in Research Triangle Park, NC. His current focus is on the peripheral stimulation mechanisms involved in intracochlear electrical stimulation for auditory prostheses.



Dewey T. Lawson received the A.B. degree from Harvard University, Cambridge, MA, in 1966, and the Ph.D. degree in physics from Duke University, Durham, NC, in 1972.

Following a postdoctoral appointment at Cornell University he returned to Duke as a member of the physics faculty. He is now Senior Scientist with the Neuroscience Program Office of Research Triangle Institute and Adjunct Associate Professor of Physics at Duke. Analysis of acoustic signals has

been the common thread linking his research in the areas of elementary excitations in quantum liquids and solids; architectural, musical, and environmental acoustics; and speech processors for auditory prostheses.



Robert D. Wolford received the B.S. degree from Indiana University of Pennsylvania, Indiana, PA, and the M.S. degree in audiology from the University of North Carolina at Chapel Hill.

He is a Clinical Audiologist and Coordinator for the Center for the Severely Hearing Impaired at Duke University Medical Center, Durham, NC. His primary clinical interest is in the evaluation and treatment of patients with severe to profound hearing

loss, including the application of hearing aids, vibrotactile devices, assistive listening devices, and cochlear implants.

Design and evaluation of a continuous interleaved sampling (CIS) processing strategy for multichannel cochlear implants

Blake S. Wilson, PhD; Charles C. Finley, PhD; Dewey T. Lawson, PhD; Robert D. Wolford, MS; Mariangeli Zerbi, MSEE

Neuroscience Program, Research Triangle Institute, Research Triangle Park, NC 27709;
Division of Otolaryngology, Duke University Medical Center, Durham, NC 27710

Abstract—Two approaches for representing speech information with multichannel cochlear prostheses are being compared in tests with implant patients. Included in these studies are the *compressed analog* (CA) approach of a standard clinical device and research processors utilizing *continuous interleaved sampling* (CIS). Initial studies have been completed with nine subjects, seven of whom were selected on the basis of excellent performance with the Ineraid clinical processor, and the remaining two for their relatively poor performance with the same device. The tests include open-set recognition of words and sentences. Every subject has obtained a higher score—or repeated a score of 100% correct—on every test when using a CIS processor. These results are discussed in terms of their implications for processor design.

Key words: cochlear prosthesis, deafness, hearing, speech perception, speech processing.

INTRODUCTION

Recent studies in our laboratory have focused on comparisons of *compressed analog* (CA) and *continuous interleaved sampling* (CIS) processors (1,2,3). Both use multiple channels of intracochlear electrical stimulation, and both represent waveforms or envelopes of speech input signals. No specific features of the input, such as the fundamental or

formant frequencies, are extracted or explicitly represented. CA processors use continuous analog signals as stimuli, whereas CIS processors use pulses. The CA approach is used in the widely applied Ineraid device (4,5) and in the now-discontinued UCSF/Storz device, with some differences in details of processor implementation (6). Wearable devices capable of supporting the CIS approach are just becoming available for use in clinical settings.

To date, we have completed initial studies of nine subjects—seven of whom were selected for their high levels of speech recognition with the Ineraid CA processor, and two who were selected for their relatively poor performances with that processor. The “high performance” subjects were representative of the best results when any commercially available implant system is used (2). Equivalent studies have been begun but not yet completed with two additional patients in the “poor performance” group (7).

This paper will briefly review the previously published results for the seven subjects in the high performance group and present preliminary results for the first two subjects from the poor performance group.

PROCESSING STRATEGIES

The designs of CA and CIS processors are illustrated in **Figure 1** and **Figure 2**. In CA proces-

Address all correspondence and requests for reprints to: Blake S. Wilson, Neuroscience Program, Research Triangle Institute, Research Triangle Park, NC 27709.

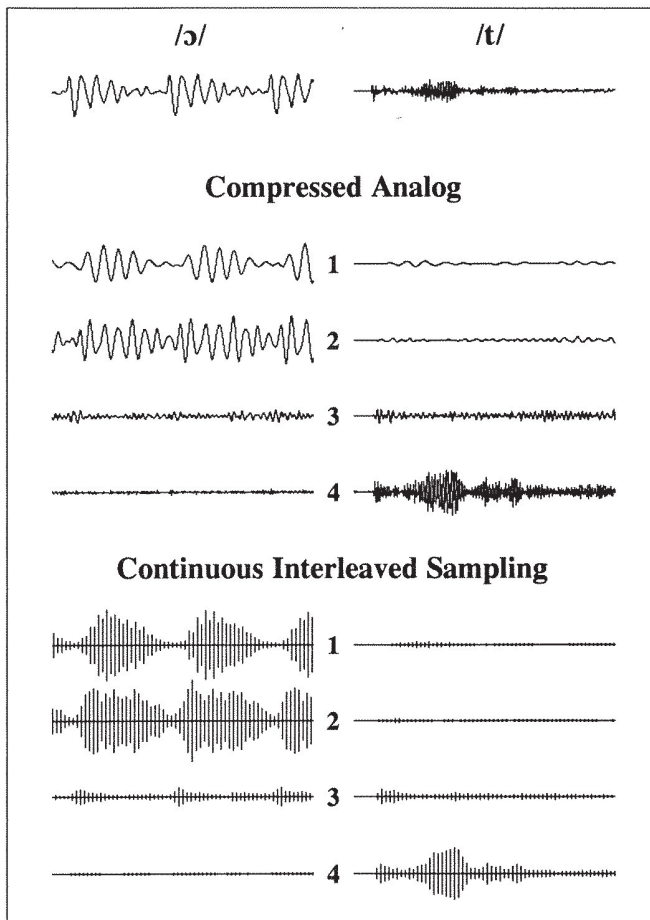

Figure 1.

Waveforms produced by simplified implementations of CA and CIS strategies. The top panel shows preemphasized (6dB/octave attenuation below 1.2 kHz) speech inputs. Inputs corresponding to a voiced speech sound ("aw") and an unvoiced speech sound ("t") are shown in the left and right columns, respectively. The duration of each trace is 25.4 ms. The remaining panels show stimulus waveforms for CA and CIS processors. The waveforms are numbered by channel, with channel 1 delivering its output to the apical-most electrode. To facilitate comparisons between strategies, only four channels of CIS stimulation are illustrated here. In general, five or six channels have been used for that strategy. The pulse amplitudes reflect the envelope of the bandpass output for each channel. In actual implementations the range of pulse amplitudes is compressed using a logarithmic or power-law transformation of the envelope signal. (From Wilson BS, et al. (2), with permission.)

sors, a microphone signal varying over a wide dynamic range is compressed or restricted to the narrow dynamic range of electrically evoked hearing (8,9) using an automatic gain control. The resulting signal is then filtered into four contiguous frequency

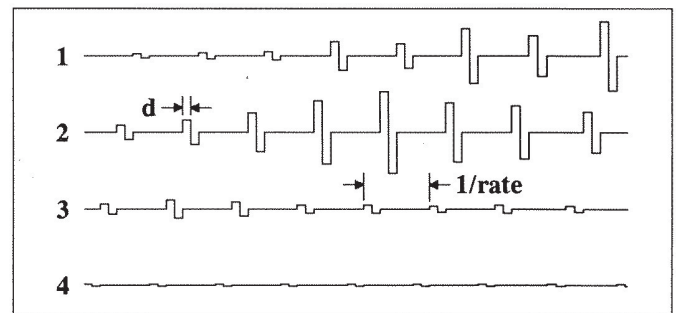

Figure 2.

Expanded display of CIS waveforms. Pulse duration per phase ("d") and the period between pulses on each channel ("1/rate") are indicated. The sequence of stimulated channels is 4-3-2-1. The total duration of each trace is 3.3 ms. (From Wilson BS, et al. (2), with permission.)

bands for presentation to each of four electrodes. As shown in **Figure 1**, information about speech sounds is contained in the relative stimulus amplitudes among the four electrode channels and in the temporal details of the waveforms for each channel.

A concern associated with this method of presenting information is that substantial parts of it may not be perceived by implant patients (10). For example, most patients cannot perceive frequency changes in stimulus waveforms above about 300 Hz (11). Thus, many of the temporal details present in CA stimuli probably are not accessible to the typical user.

In addition, the simultaneous presentation of stimuli may produce significant interactions among channels through vector summation of the electric fields from each electrode (12). The resulting degradation of channel independence would be expected to reduce the salience of channel-related cues. That is, the neural response to stimuli from one electrode may be significantly distorted, or even counteracted, by coincident stimuli from other electrodes.

The CIS approach addresses the problem of such channel interactions through the use of interleaved nonsimultaneous stimuli (**Figure 2**). Trains of balanced biphasic pulses are delivered to each electrode with temporal offsets that eliminate any overlap across channels. The amplitudes of the pulses are derived from the envelopes of bandpass filter outputs. In contrast with the four-channel clinical CA processors, five or six bandpass filters (and channels of stimulation) have generally been

used in CIS systems to take advantage of additional implanted electrodes and reduced interactions among channels. The envelopes of the bandpass outputs are formed by rectification and lowpass filtering. Finally, the amplitude of each stimulus pulse is determined by a logarithmic or power-law transformation of the corresponding channel's envelope signal at that time. This transformation compresses each signal into the dynamic range appropriate for its channel.

A key feature of the CIS approach is its relatively high rate of stimulation on each channel. Other pulsatile strategies present sequences of interleaved pulses across electrodes at a rate equal to the estimated fundamental frequency during voiced speech and at a jittered or fixed (often higher) rate during unvoiced speech (13,14,15). Rates of stimulation on any one channel have rarely exceeded 300 pulses per second (pps). In contrast, the CIS strategy generally uses brief pulses and minimal delays, so that rapid variations in speech can be tracked by pulse amplitude variations. The rate of stimulation on each channel usually exceeds 800 pps and is constant during both voiced and unvoiced intervals. A constant high rate allows relatively high cutoff frequencies for the lowpass filters in the envelope detectors. With a stimulus rate of 800 pps, for instance, lowpass cutoffs can approach (but not exceed) 400 Hz without introducing aliasing errors in the sampling of the envelope signals at the time of each pulse. See Rabiner and Shafer for a complete discussion of aliasing and its consequences (16).

METHODS

Each of the nine subjects has been studied for a 1-week period during which: (a) basic psychophysical measures were obtained on thresholds and dynamic ranges for pulsatile stimuli; (b) various CIS processors (with different choices of processor parameters) were evaluated with preliminary tests of consonant identification; and, (c) performance with the best of the CIS processors and the clinical CA processor was documented with a broad spectrum of speech tests. Experience with the clinical processor exceeded one year of daily use for all subjects. In contrast, experience with the CIS processors was limited to no more than several hours before formal testing.

Tests

The comparison tests include open-set recognition of 50 one-syllable words from Northwestern University Auditory Test 6 (NU-6), 25 two-syllable words (spondees), 100 key words in the Central Institute for the Deaf (CID) sentences of everyday speech, and the final word in each of 50 sentences from the Speech Perception in Noise (SPIN) Test (here presented without noise). All tests are conducted with hearing alone, using single presentations of recorded material, and without feedback about correct or incorrect responses.

Processor Parameters

Each subject's own clinical device is used for the tests with the CA processor. As mentioned above, selection of parameters for the CIS processor is guided by preliminary tests of consonant identification. The standard four channels of stimulation are used for the clinical CA processors (4,5), whereas five or six channels have been used for the CIS processors. Additional parameters of the CIS processors are presented in **Table 1**. As indicated there, all CIS processors for the high performance subjects, SR2 to SR8, have had pulse durations of 102 μs /phase or less, zero delay between the sequential pulses on different channels, pulse rates of 817 pps or higher on each channel, and a cutoff frequency for the lowpass filters of 400 Hz or higher. The best processor for subject SR1 also fit this description, except that a delay of 172 μs was interposed between sequential pulses. The best processor for subject SR10 used long-duration pulses (167 μs /phase), paired with a relatively low rate of stimulation on each channel (500 pps) and a relatively low cutoff frequency for the lowpass filters (200 Hz).

Evaluation of Practice and Learning Effects

Because the tests with the CA processor preceded those with the selected CIS processor for each subject, we were concerned that practice or learning effects might favor the latter in comparisons of the two strategies. To evaluate this possibility, the CID and NU-6 tests were repeated with the CIS processor for five of the high performance subjects (subjects SR3, SR4, SR6, SR7, and SR8). A different recorded speaker and new lists of words and sentences were used. Practice or learning effects would be demonstrated by significant differences in the

Table 1.
Parameters of CIS processors.

Subject	Channels	Pulse Duration ($\mu\text{s}/\text{phase}$)	Rate (pps)	Integrating Filter Cutoff (Hz)
SR2	6	55	1515	800
SR3	6	31	2688	400
SR4	6	63	1323	400
SR5	6	31	2688	800
SR6	6	102	817	400
SR7	5	34	2941	400
SR8	6	100	833	400
SR1	5	34	833	400
SR10	6	167	500	200

Parameters include number of channels, pulse duration, the rate of stimulation on each channel (Rate), and the cutoff frequency of the lowpass integrating filters for envelope detection (Integrating Filter Cutoff). The subjects are listed in the chronological order of their participation in the present studies. SR2 through SR8 are the "high performance" subjects while SR1 and SR10 belong to the "low performance" group. Additional processor parameters may be found in References 3 and 7.

test/retest scores. Nevertheless, no such differences were found ($p > 0.6$ for paired t comparisons of the CID scores; $p > 0.2$ for the NU-6 scores), and the scores from the first and second tests were averaged for all subsequent analyses.

RESULTS

The results from 1-week studies of each of the nine subjects are presented in **Table 2** and **Figure 3**. Scores for the high performance subjects are indicated by the light lines near the top of each panel in **Figure 3**, and scores for the two low performance subjects are indicated by the dark lines closer to the bottom of each panel. We note that low performance subject SR1 had participated in an earlier study not involving CIS processors (15). Results from his first week of testing with CIS processors are presented here. This is also true of high performance subject SR2, who has returned to the laboratory for many additional studies with various implementations of CIS processors (1). In those subsequent tests, SR2 has achieved even higher scores using a variety of six-channel CIS processors, with NU-6 percentages ranging from the high 80s to the low 90s.

As is evident from the figure, all nine subjects have scored higher, or repeated a score of 100

percent correct, on every test, when using a CIS processor. The average scores across subjects increased from 64 to 86 percent correct on the spondee test ($p < 0.01$), from 70 to 91 percent correct on the CID test ($p < 0.02$), from 39 to 76 percent correct on the SPIN test ($p < 0.001$), and from 34 to 54 percent correct on the NU-6 test ($p < 0.0002$).

Perhaps the most encouraging of these results are the improvements for the two low performance subjects. CA scores were low for SR1 and quite poor for SR10. Substitution of a CIS processor produced large gains in speech recognition for both subjects. Indeed, with the CIS processor SR1 has scores that fall within the ranges of CA processor scores that qualified subjects SR2 to SR8 as among the best performers with any clinical device.

Similarly, SR10 achieved relatively high scores with the CIS processor. The score on the spondee test increased from 0 to 56 percent correct, on the CID test from 1 to 55 percent correct, on the SPIN test from 0 to 26 percent correct, and on the NU-6 test from 0 to 14 percent correct. These increases were obtained with no more than several hours of aggregated experience with CIS processors, compared with more than a year of daily experience with the clinical CA processor.

Note that although these gains for SR10 are large, they are not atypical of results for the other subjects. His improvements follow the pattern of the

Table 2.
Individual results from the open-set tests.

Subject	Spondee		CID		SPIN		NU-6	
	CA	CIS	CA	CIS	CA	CIS	CA	CIS
SR2	92	96	100	100	78	96	56	80
SR3	52	96	66	98	14	92	34	58
SR4	68	76	93	95	28	70	34	40
SR5	100	100	97	100	94	100	70	80
SR6	72	92	73	99	36	74	30	49
SR7	80	100	99	100	66	98	38	71
SR8	68	100	80	100	36	94	38	66
SR1	40	60	25	70	2	30	6	32
SR10	0	56	1	55	0	26	0	14

other subjects, i.e., generally large gains in the scores of tests that are not limited by ceiling effects. The distinctive aspect of SR10's results is that he enjoys such gains even though he started at or near zero on all four tests. Thus, the relative improvements for SR10 are larger than those for any other subject in the series thus far.

DISCUSSION

The findings presented in this paper demonstrate that the use of CIS processors can produce large and immediate gains in speech recognition for a wide range of implant patients. Indeed, the sensitivity of some of the administered tests has been limited by ceiling (or saturation) effects: five of the seven high performance subjects scored 96 percent or higher for the spondee test using CIS processors; all seven scored 95 percent or higher for the CID test; and five scored 92 percent or higher for the SPIN test. Scores for the NU-6 test, although not approaching the ceiling, were still quite high. The 80 percent score achieved by two of the subjects corresponds to the middle of the range of scores obtained by people with mild-to-moderate hearing losses when taking the same test (17,18).

The improvements are even more striking when one considers the large disparity in experience with the two processors. At the time of our tests each subject had 1 to 5 years of daily experience with the

CA processor but only several hours over a few days with CIS. In previous studies involving within-subjects comparisons, such differences in experience have strongly favored the processor with the greatest duration of use (19,20,21).

Factors contributing to the performance of CIS processors might include: (a) reduction in channel interactions through the use of nonsimultaneous stimuli; (b) use of five or six channels instead of four; (c) representation of rapid envelope variations through the use of relatively high pulse rates; (d) preservation of amplitude cues with channel-by-channel compression; and, (e) the shape of the compression function.

An interesting aspect of the ongoing studies with low performance subjects, represented here by SR1 and SR10, is that the best CIS processors seem to involve parameters distinct from those of the best processors for subjects in the high performance group. The best processor for SR1 used short-duration pulses (34 μ s/phase) presented at a relatively low rate (833 pps), and the best processor for SR10 used long-duration pulses (167 μ s/phase) presented at an even lower rate (500 pps). The subjects in the high performance group, however, often obtained their best scores with processors tending to minimize pulse widths and maximize pulse rates (e.g., 31 μ s/phase pulses presented at 2688 pps).

The use of such shorter pulses and higher rates allows representation of higher frequencies in the modulation waveform for each channel (i.e., the

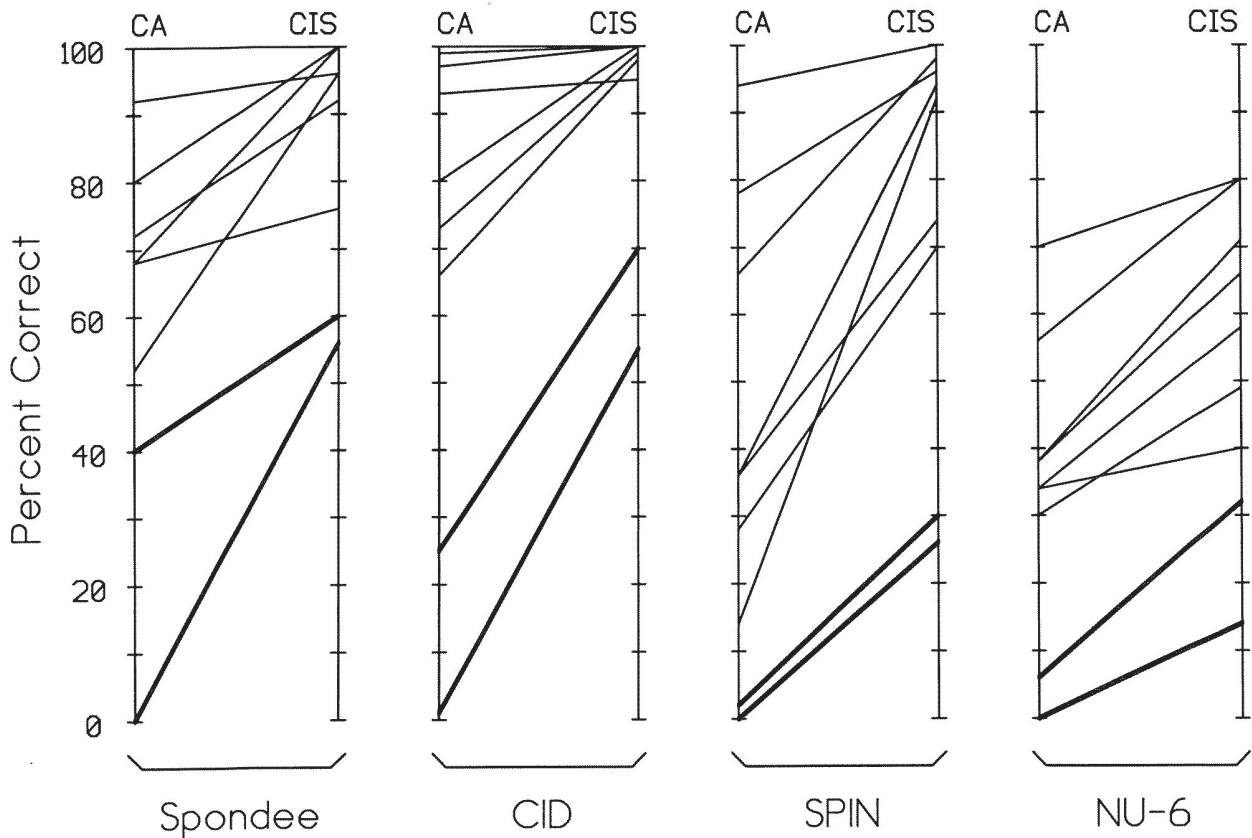

Figure 3.

Speech recognition scores for CA and CIS processors. A line connects the CA and CIS scores for each subject. Light lines correspond to the seven subjects selected for their excellent performance with the clinical CA processor, whereas the heavier lines correspond to the two subjects selected for relatively poor performance.

cut-off frequency of the lowpass filter in the envelope detectors for each channel may be raised to one-half of the pulse rate without introducing aliasing effects). In addition, the dynamic range (DR) of electrical stimulation—from threshold to most comfortable loudness—is a strong function of pulse rate and a weaker function of pulse duration (11,22). Large increases in DR are generally found with increases in pulse rates from about 400 pps to 2500 pps. Smaller increases often (but not always) are observed with increases in pulse duration (at a fixed rate of stimulation) from roughly $50 \mu\text{s}/\text{phase}$ to higher values (e.g., out to $200 \mu\text{s}/\text{phase}$ for practical CIS designs).

For some patients, however, these advantages may be outweighed by other factors. For several subjects in our Ineraid series, for instance, we have observed that the salience of channel ranking can decline with decreases in pulse widths below

$100 \mu\text{s}/\text{phase}$. A favorable tradeoff for such subjects might involve the use of long-duration pulses (e.g., $100 \mu\text{s}/\text{phase}$ or greater) to preserve channel cues, while foregoing any additional DR obtainable with shorter pulses and higher rates of stimulation.

Another possible advantage of relatively low rates of stimulation is further reduction of channel interactions. Providing time between pulses on sequential channels can reduce the “temporal integration” component of channel interactions—a component produced by the accumulation of charge at neural membranes from sequential stimuli (12). Thus, use of time delays between short-duration pulses in the stimulation sequence across electrodes may reduce interactions. Alternatively, use of long-duration pulses with no time delay also might reduce temporal interactions in that a relatively long period still is realized between the excitatory phases of successive pulses.

Collectively, the present results indicate that: (a) the performance of at least some patients with poor clinical outcomes can be improved substantially with use of a CIS processor; (b) use of long-duration pulses produced large gains in speech test scores for one such subject; (c) use of short-duration pulses presented at a relatively low rate produced similar improvements in another such subject; and, (d) the optimal tradeoffs among pulse duration, pulse rate, interval between sequential pulses, and cutoff frequency of the lowpass filters seem to vary from patient to patient. Studies are underway to evaluate CIS processors for additional subjects in the low performance group and to investigate in detail the tradeoffs among processor parameters for subjects in both the low and high performance groups.

ACKNOWLEDGMENTS

We thank the subjects of the described studies for their enthusiastic participation. We also are pleased to acknowledge the important scientific contributions of Michael F. Dorman, Donald K. Eddington, William M. Rabinowitz, and Robert V. Shannon. This work was supported by NIH project N01-DC-9-2401, through the Neural Prosthesis Program.

REFERENCES

1. Lawson DT, Wilson BS, Finley CC. New processing strategies for multichannel cochlear prostheses. *Prog Brain Res*. In press.
2. Wilson BS, Finley CC, Lawson DT, Wolford RD, Eddington DK, Rabinowitz WM. Better speech recognition with cochlear implants. *Nature* 1991;352:236-8.
3. Wilson BS, Lawson DT, Finley CC. Speech processors for auditory prostheses. Bethesda (MD): National Institutes of Health, 1990. 4th Quarterly Progress Report, NIH project N01-DC-9-2401.
4. Eddington DK. Speech discrimination in deaf subjects with cochlear implants. *J Acoust Soc Am* 1980;68:885-91.
5. Eddington DK. Speech recognition in deaf subjects with multichannel intracochlear electrodes. *Ann NY Acad Sci* 1983;405:241-58.
6. Merzenich MM, Rebscher SJ, Loeb GE, Byers CL, Schindler RA. The UCSF cochlear implant project. State of development. *Adv Audiol* 1984;2:119-44.
7. Wilson BS, Lawson DT, Finley CC, Zerbi M. Speech processors for auditory prostheses. Bethesda (MD): National Institutes of Health, 1992. 11th Quarterly Progress Report, NIH project N01-DC-9-2401.
8. Pfingst BE. Operating ranges and intensity psychophysics for cochlear implants. *Arch Otolaryngol* 1984;110:140-4.
9. Shannon RV. Multichannel electrical stimulation of the auditory nerve in man. I. Basic psychophysics. *Hear Res* 1983;11:157-89.
10. Wilson BS, Finley CC, Lawson DT. Representations of speech features with cochlear implants. In: Miller JM, Spelman FA, editors. *Cochlear implants: Models of the electrically stimulated ear*. New York: Springer-Verlag, 1990:339-76.
11. Shannon RV. Psychophysics. In: Tyler RS, editor. *Cochlear implants: audiological foundations*. Chap. 3. San Diego (CA): Singular Publishing Group. In press.
12. White MW, Merzenich MM, Gardi JN. Multichannel cochlear implants: channel interactions and processor design. *Arch Otolaryngol* 1984;110:493-501.
13. Clark GM. The University of Melbourne-Nucleus multi-electrode cochlear implant. *Adv Otorhinolaryngol* 1987;38:1-189.
14. Wilson BS. Signal processing. In: Tyler RS, editor. *Cochlear implants: audiological foundations*. Chap. 2. San Diego (CA): Singular Publishing Group. In press.
15. Wilson BS, Lawson DT, Finley CC, Wolford RD. Coding strategies for multichannel cochlear prostheses. *Am J Otol* 1991;12(1 Suppl):56-61.
16. Rabiner LR, Shafer RW. *Digital processing of speech signals*. Englewood Cliffs (NJ): Prentice-Hall, 1978.
17. Bess FH, Townsend TH. Word discrimination for listeners with flat sensorineural hearing losses. *J Speech Hear Disord* 1977;42:232-7.
18. Dubno JR, Dirks DD. Evaluation of hearing-impaired listeners using a nonsense syllable test. I. Test reliability. *J Speech Hear Res* 1982;25:135-41.
19. Dowell RC, Brown AM, Mecklenburg DJ. Clinical assessment of implanted deaf adults. In: Clark GM, Tong YC, Patrick JF, editors. *Cochlear prostheses*. Edinburgh: Churchill Livingstone, 1990:193-205.
20. Dowell RC, Seligman PM, Blamey PJ, Clark GM. Evaluation of a two-formant speech-processing strategy for a multichannel cochlear prosthesis. *Ann Otol Rhinol Laryngol* 1987;96(128 Suppl):132-4.
21. Tyler RS, Preece JP, Lansing CR, Otto SR, Gantz BJ. Previous experience as a confounding factor in comparing cochlear-implant processing schemes. *J Speech Hear Res* 1986;29:282-7.
22. Wilson BS, Lawson DT, Finley CC, Zerbi M. Speech processors for auditory prostheses. Bethesda (MD): National Institutes of Health, 1991. 9th Quarterly Progress Report, NIH project N01-DC-9-2401.

Thirty years of the *British Journal of Audiology*: Guest editorial

The future of cochlear implants

Blake S. Wilson

Center for Auditory Prosthesis Research, Research Triangle Institute, Research Triangle Park, NC 27709, USA

(Received 9 June 1997, accepted 13 June 1997)

Abstract

Remarkable progress has been made in recent years in the design and application of processing strategies for cochlear implants. Most notably, use of the new spectral peak (SPEAK) and continuous interleaved sampling (CIS) strategies have provided large improvements in speech reception performance compared with prior strategies (NIH Consensus Statement, 1995; Skinner *et al.*, 1994a; Wilson *et al.*, 1991). All major manufacturers of multichannel implant systems, including Advanced Bionics Corp., Bionic Systems, Cochlear Pty. Ltd., and Med El, now offer CIS or CIS-like strategies in their speech processors. The SPEAK strategy was developed by Cochlear Pty. Ltd and continues to be one of the options available in that company's devices.

The principal purpose of this editorial is to present some of the many possibilities for further improvements in performance. To the extent that such possibilities are realized, implant systems of the future may be quite different from present systems, with different processing strategies, electrode designs, telemetry features, and fitting procedures.

Present levels of performance

One of the most striking findings from research on implants is that the range of performance across patients is large for any of a variety of implant systems. Some patients score at or near 100% correct on standard audiological tests of sentence and word recognition in quiet, whereas other patients obtain zero scores using an identical speech processor and electrode array. Although average scores across patients have increased with the new processing strategies, a wide range of performance still remains.

At the high end of the performance spectrum patients can communicate with ease in many listening situations. This is surprising in that many functions of the normal cochlea are only crudely if at all replaced by present implant systems. The representation of speech information can be sparse and crude and yet still sufficient for open set recognition by some patients.

Although performance in many listening situations is excellent for such patients, performance in noisy environments or in situations with multiple speakers could be improved. Indeed, a common

complaint of implant (and hearing aid) users is that understanding of speech in the latter situations is much degraded compared to listening to a single speaker in quiet. The degradations with implant users appear to be much larger than the degradations observed for people with normal hearing.

A closer mimicking of cochlear functions may help close the gap between the best implant users' performance and that of normals for adverse listening situations. Also, coordinated bilateral stimulation may help restore an ability to localize sounds from different sources for implant recipients. This ability in normals improves dramatically speech reception performance in environments with disparate sources of signal and noise, or of a primary speaker and competitors.

A more urgent goal is to provide assistance to patients at the low end of the performance spectrum. A first step, of course, will be to identify the factor or factors that place patients in this unfortunate category. Possible factors include differences among patients in the number and

distribution of surviving neurons in the implanted cochlea, physiologic function of the surviving neurons, surgical placement of the intracochlear electrodes, integrity of the central auditory pathways, and cognitive and language skills. In addition, motivation, support from others, and psychological well being may affect outcomes with implants.

A number of recent studies have been conducted to evaluate possible correlations between speech reception scores and various preoperative and postoperative measures (e.g. Dorman *et al.*, 1989; Kileny *et al.*, 1991; Blamey *et al.*, 1992; Shirota *et al.*, 1992; Gantz *et al.*, 1993; Battmer *et al.*, 1995; Shipp and Nedzelski, 1995; Summerfield and Marshall, 1995; Blamey *et al.*, 1996). Results from most of the studies demonstrate a weak but significant negative correlation between duration of deafness prior to implantation and postoperative speech reception scores. In addition, patients with prelinguistic or perilinguistic onsets of deafness on average obtain lower scores than patients with postlinguistic onsets. Weak correlations also have been demonstrated in some studies between speech reception scores and other measures, such as the number of electrodes inserted into the cochlea and the ability of patients to discriminate changes in pulse rates with promontory stimulation. None of the factors identified to date explains a large proportion of the variance in postoperative speech reception results.

Identification of a factor or factors explaining a large proportion of the variance could help target efforts to present speech information in a way that would compensate for specific deficits. Several new studies are underway to evaluate relationships among psychophysical measures, speech reception measures, and direct measures of nerve and CNS condition (e.g. Brown *et al.*, 1996). A recently achieved ability to record intracochlear evoked potentials (EPs) in patients who have percutaneous connectors has allowed inferences of the number and physiological status of auditory neurons on an electrode-by-electrode basis (Brown *et al.*, 1990; Wilson *et al.*, 1994a; Wilson *et al.*, in press). In addition, such recordings can provide information on channel interactions and forward masking functions at the level of the auditory nerve. Recordings of intracochlear EPs should allow us to evaluate possible correlations between peripheral function and speech reception performance. If significant correlations are found, then such recordings also may allow us to

tailor the fitting of speech processors according to demonstrated strengths and weaknesses in peripheral function for individual patients.

Recordings of electrically evoked auditory brain stem responses (EABRs) in the same patients will allow comparisons of peripheral and central representations of the stimuli. As with intracochlear EPs, EABRs may become useful in the fitting of speech processors if significant correlations are demonstrated for EABR and speech reception measures.

One of the principal recommendations from the recent NIH Consensus Development Conference on Cochlear Implants in Adults and Children was support of research 'to explain the wide variation in performance across individual implant users'. As noted in the Consensus Statement, measures of central auditory function, as might be obtained through functional imaging of brain structures, should be included in such research. Measures of cognitive processes also should be included, such as traditional psychological tests and recordings of cognitive evoked potentials. Psychological tests are being conducted at the University of Iowa (Knutson *et al.*, 1991; Gantz *et al.*, 1993) and recordings of cognitive evoked potentials are being made at several centres (Kileny, 1991; Kraus *et al.*, 1995; Micco *et al.*, 1995; Ponton and Don, 1995).

Another potential source of variation in results is the positions of electrodes with respect to excitable tissue. Skinner *et al.* (1994b) are using an enhanced CT scanning technique to measure the positions in a series of patients implanted with the Nucleus device. The resolution of the technique is sufficient for useful estimates of placements within the cross section of the scala tympani. Having electrodes close to the inner wall of the scala tympani, in proximity to Rosenthal's canal and the spiral ganglion cells within it, can mean lower thresholds, wider dynamic ranges, and most likely greater spatial resolution of stimulation (Ranck, 1975; Shepherd *et al.*, 1993). Such effects of close placement may support improved speech reception performance.

Results from the studies indicated above are likely to refine or change the way we think about patients at the low end of the performance spectrum. Hopefully, the results will provide insights as to how performance might be improved, perhaps through changes in processor or electrode design, or perhaps through different choices of parameter values for existing implant systems.

Variations in CIS and 'n-of-m' strategies

In CIS strategies the same n electrodes, corresponding to n frequency bands and n channels, are included in each cycle of stimulation across the array of active electrodes. In 'n-of-m' strategies, n electrodes are selected from a total of m electrodes, corresponding to m analysed frequency bands, for each cycle. The n electrodes usually are selected on the basis of the highest n bandpass envelope signals among the m available signals at the onset of each cycle.

Processors using an n-of-m approach include a variation of an 'interleaved pulses' processor developed by our group (Wilson *et al.*, 1985; 1988), the SMSP or spectral maxima sound processor developed at the University of Melbourne (McDermott *et al.*, 1992; McDermott and Vandali, 1997), the SPEAK processor mentioned above, and the ACE or advanced combination encoder strategy to be offered as a processing option in Cochlear Pty Ltd's new CI24M implant system.

Recent comparisons among various implementations of CIS and n-of-m processors have indicated certain choices of parameter values likely to produce gains in speech reception performance (Lawson *et al.*, 1996a). In particular, significant gains were produced for the five studied subjects when (1) the total range of frequencies spanned by the bandpass filters in either CIS or n-of-m processors was extended upward from 5.6 to 9.5 kHz or (2) the rate of stimulation on each electrode of a CIS processor, or each selected electrode of an n-of-m processor, was increased from 250 to 833 pulses/s. The best results among the tested processors were for those processors that incorporated both the extended frequency range and the higher rate. Increases in rate from 833 to 2525 pulses/s did not produce further increases in performance across these subjects, nor did manipulations in pulse polarity or channel update order.

Results with CIS and n-of-m processors using the extended frequency range and rates at and above 833 pulses/s were significantly better than those obtained with a monopolar version of the clinical SPEAK processor, which had been used by the subjects for at least 18 months prior to the comparisons. The SPEAK processor uses an extended frequency range but stimulates the selected electrodes at rates of about 250 pulses/s. Performance with CIS processors using the narrow frequency range was not significantly different from that

obtained with the SPEAK processor for the five subjects of this study.

Although performance of the subjects as a group was not correlated with increases in rate above 833 pulses/s, or to manipulations in pulse polarity or channel update order, performance of individual subjects was sensitive to each of these parameter choices. Thus, a good starting point for fitting would be to set the rate at approximately 800 pulses/s and to use an extended frequency range for the bandpass filters. Then adjustments in rate (both up and down) and manipulations in pulse polarity and channel update order might well produce additional gains in performance.

Development of fitting procedures

Large improvements in the performance of CIS and n-of-m processors can be realized through appropriate fitting (see, for instance, Fig. 10 and the accompanying discussion in Wilson *et al.*, 1995b). As suggested above, predetermined values for some parameters may be appropriate for virtually all patients. However, the values of other parameters should be varied over certain ranges to optimize performance for individuals. An objective of current and planned research is to identify values that can be fixed and values that must be varied to approximate optimal performance within and across patients. Results of such research may well inform the development of efficient and effective fitting procedures.

Number of channels and choice of electrodes

Another possibility for improvement in the performance of implant systems is use of a relatively small numbers of electrodes, selected from among a larger implanted set. Data that support this approach are presented in Figure 1, from studies in which the number of channels for CIS processors, and choices among available electrodes, were manipulated (Lawson *et al.*, 1993; Wilson *et al.*, 1994c; Lawson *et al.*, 1996a). The subjects included one patient with a six-electrode Ineraid implant (subject SR2) and five patients with percutaneous connector versions of the 22-electrode Nucleus array (subjects NP1-5). The rate of stimulation for all conditions for SR2 was 2525 pulses/s on the selected electrodes. For NP1-5 the rate was 833 pulses/s for all conditions except the 21-channel condition, where the rate was reduced to 721 pulses/s to preserve non-simultaneity of stimulation across channels. At

least two variations of 6-channel processors, with different choices of electrodes, were included among the conditions for subjects NP1-5. In addition, different electrodes were used for three single-channel processors tested with subject NP4 and for two single-channel processors tested with subject NP5. The electrode selections for the 6-channel processors were equivalent in terms of pitch discrimination data and (within .75 mm) the overall cochlear distance spanned. Values for other parameters were held constant across conditions and subjects. The various processors were evaluated with tests of consonant identification, using recordings of a male speaker and a female speaker. A 24 consonant test was used for three subjects whose high scores with a 16 consonant test reduced that test's sensitivity (subjects SR2, NP1 and NP2). All tests were conducted with hearing alone and with no feedback as to correct or incorrect responses.

Figure 1 shows the averages of percent correct scores for the male and female speakers. The averages were computed from at least 10 block scores for each speaker (see Lawson *et al.*, 1996a). The error bars show standard deviations of the mean. Results from a one-way analysis of

the variance (ANOVA) of the data for each subject are indicated by the *p* values.

The ANOVAs indicate significance in all cases, indicating differences in scores among the conditions for each of the subjects. Results from *post hoc* comparisons of the means, using a Fisher least significant difference criterion ($P < 0.05$), are presented in Table 1. As is evident from the table and the figure, most of the significant differences are found among conditions with low numbers of channels. In addition, significant differences are found between 6-channel processors with different choices of electrodes for all Nucleus percutaneous subjects except NP4. The variation in percent correct scores is relatively small beyond the 4-channel condition for all subjects except SR2. In no case is an 8, 11 or 21 channel result better than the best 6-channel result.

Findings similar to these have been reported by Brill *et al.* (in press), Brill and Hochmair (1997), Kiefer *et al.* (1996, 1997), and Fishman *et al.* (in press). Fishman *et al.* studied variations in the number of active electrodes used with SPEAK processors and the other investigators studied variations in the number of electrodes (and channels) used with CIS processors. In all

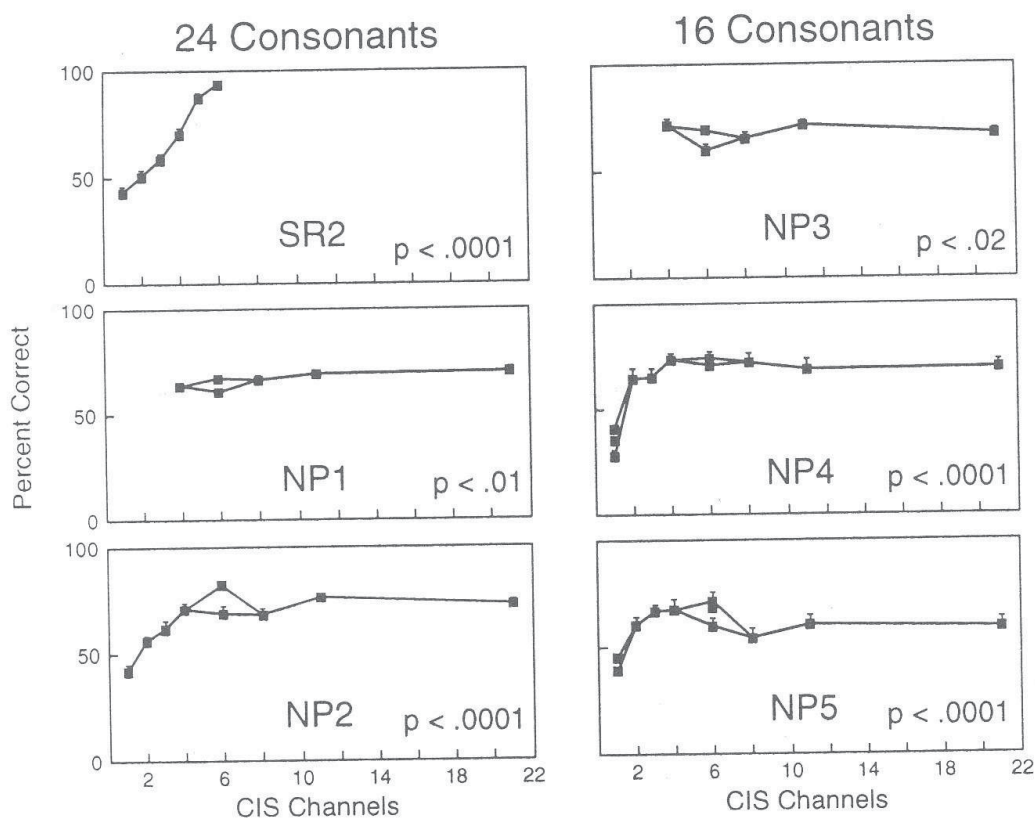

Fig. 1. Effects of manipulations in number of channels and channel-to-electrode assignments

Table 1. Significant differences among conditions in a study to evaluate effects of number of channels and channel to electrode assignments on the performance of CIS processors (alternate assignments are denoted by alt and alt')

Subject	Significant differences	
SR2	2, 3, 4, 5, 6 >	1
	3, 4, 5, 6 >	2
	4, 5, 6 >	3
	5, 6 >	4
NP1	6alt, 8, 11, 21 >	6
	11, 21 >	4
NP2	2, 3, 8, 6alt, 4, 21, 11, 6 >	1
	8, 6alt, 4, 21, 11, 6 >	2
	6alt, 4, 21, 11, 6 >	3
	11, 6 >	8, 6alt
	6 >	4, 21
NP3	21, 6, 11, 4 >	6alt
NP4	1, 2, 3, 11, 21, 6, 8, 4, 6alt >	1alt'
	2, 3, 11, 21, 6, 8, 4, 6alt >	1alt, 1
NP5	8, 21, 6alt', 2, 11, 3, 4, 6, 6alt >	1
	21, 6alt', 2, 11, 3, 4, 6, 6alt >	1alt
	3, 4, 6, 6alt >	8
	6alt >	21, 6alt', 2, 11

studies speech reception performance increased with increases in the number of channels up to 4 or 6. Further increases did not on average produce further gains in performance.

For present electrode designs, both number of channels and choice among available electrodes can affect the performance of CIS processors. Use of more than 4–6 channels is not likely to produce significant improvements in performance, but selection of electrodes can significantly affect performance for processors with as many as 6 channels.

The principal advantage of electrode arrays having many electrodes lies not in supporting a large number of channels, but rather in supporting the selection of electrode subsets to optimize performance.

Use of only 4 to 6 channels also allows specification of optimal values for other parameters, such as rate of stimulation. Implant hardware often imposes a limit on the maximum aggregate rate of stimulation across electrodes. Thus, relatively high rates can be specified for each electrode if the total number of active electrodes is small, whereas low rates are imposed if the total number of active electrodes is high. As described below, high rates may support a high-fidelity

representation of the modulation waveforms for CIS and other processors. An optimum tradeoff between number of electrodes (or channels) and rate of stimulation may be to stimulate relatively few (carefully selected) electrodes at relatively high rates. Results from the recent studies of Brill *et al.*, Brill and Hochmair, and Kiefer *et al.* support this idea. In each of those studies both rate of stimulation and number of channels were manipulated. The hardware of the implant systems used in these studies supported aggregate rates of 12000 (Med El Combi 40) or 18000 (Med El Combi 40+) pulses/s. For a constant rate of stimulation on the active electrodes, manipulation in the number of channels produced the results cited above. Use of higher rates of stimulation, as permitted by the implant hardware for fewer than the maximum number of channels, generally produced improvements in performance for a given number of channels. Kiefer *et al.* found that decrements in performance accompanied reductions in rate below 1500 pulses/s/channel, and that improvements in performance accompanied increases in rate above 3000 pulses/s/channel. Use of more than 4 channels did not improve performance across subjects. Brill *et al.* and Brill and Hochmair also observed improvements with

increases in rate. In addition, for some subjects they observed a small peak in performance at 4, 6 or 8 channels when the maximum rate supported by the hardware was used. Quite large improvements in performance were produced for 2 channel processors by increasing the rate from 1515 to 9090 pulses/s/channel.

There appears to be an inconsistency between the present results for implant patients and earlier results from studies with channel vocoders, using subjects with normal hearing. The vocoder results indicated improvements in speech reception performance with the addition of channels up to a total of 8 to 12 channels (see, e.g., Hill *et al.*, 1968; Flanagan, 1972), whereas the results with implant patients indicate asymptotic or peak performance at 4–8 channels, usually closer to 4. One possible explanation for the apparent gap between findings for vocoder and implant studies is that listeners with normal hearing enjoy a higher selectivity of stimulation among channels than implant patients. If so, the gap in findings might be narrowed or closed with new electrode designs that provide more focused and discrete patterns of stimulation compared with present designs.

Recordings of intracochlear evoked potentials

Recordings of intracochlear evoked potentials provide information on how electrical stimuli are represented in population responses of the auditory nerve. This information might be applied in the design of new speech processing strategies and in inferring anatomical and physiological properties of neurons in the implanted cochlea.

The system we use for such recordings is illustrated in Fig. 2 (Wilson *et al.*, 1994a; Wilson *et al.*, in press). Intracochlear potentials are measured differentially between an unstimulated electrode in the implant and an electrode at the ipsilateral mastoid. Body potential is measured with a reference electrode at the wrist. Stimuli are delivered between an intracochlear electrode and a reference electrode implanted in the temporalis muscle (monopolar stimulation) or between two intracochlear electrodes (bipolar stimulation). A fast recovery amplifier is used to restore sensitivity of recording as soon as possible after saturation of the input by stimulus pulses. In addition, an equal number of sweeps for negative leading and positive leading biphasic pulses are summed to cancel components of the artifact that occur after cessation of stimulus pulses. With these techniques, use of the blanker circuit generally is not necessary for clear separation of EPs from residual artefacts.

This arrangement for recording intracochlear EPs can be used with implant systems having a percutaneous connector, for instance the Ineraid electrode and percutaneous connector as shown in Fig. 2. We also have made recordings with subjects implanted with a percutaneous connector version of the 22-electrode Nucleus array.

Examples of recordings for three subjects are presented in Fig. 3 (the blanker circuit was not used in obtaining EP data for this and subsequent figures). The stimuli in these examples were 200 ms trains of identical 33 μ s/phase pulses, with pulse rates of 100, 401 and 1016/s. Monopolar stimulation was used. For each of the three subjects, the amplitude of the pulses was adjusted to produce a most-comfortable-loudness (MCL) percept for the 1016 pulses/s condition. This amplitude was held constant for the lower rates, producing percepts with lower loudnesses.

The figure shows the first 6 ms of the 200 ms records for each subject. The large downward 'spikes' are residual (uncanceled) artefact during and shortly after presentations of stimulus pulses. Following these pulse artifacts are neural evoked potentials, with a negative peak approximately 250 μ s after pulse onset (N_1) and a positive peak approximately 600 μ s after pulse onset (P_1). The magnitudes of the EPs, as measured by the absolute difference between the peak voltages at N_1 and P_1 , range up to several mV for the subjects and conditions of Fig. 3.

For relatively low rates of stimulation EPs reflect the identical amplitudes of the pulses. For the 401 pulses/s conditions in Fig. 3, for example, nearly equal EPs are observed across the three illustrated pulses for each subject. At higher rates an alternating pattern of response is observed, with a large EP following the first pulse, a much diminished EP following the second pulse, a partially recovered EP following the third pulse, another small EP following the fourth pulse, and so on. Such patterns may in part be an expression of the refractory properties of auditory neurons. Presumably, many neurons are available for stimulation by the first pulse, when the nerve is at rest and the excitability of each neuron is at its maximum. Neurons stimulated by that pulse then become refractory to subsequent stimulation. At the time of the second pulse, approximately 1 ms later, those neurons would be in a period of relative refraction (Hartmann *et al.*, 1984; Parkins, 1989), with reduced excitability. Thus, not as many neurons would be expected to respond to the second pulse. At the time of the third pulse, neurons stimulated by the first pulse but not the

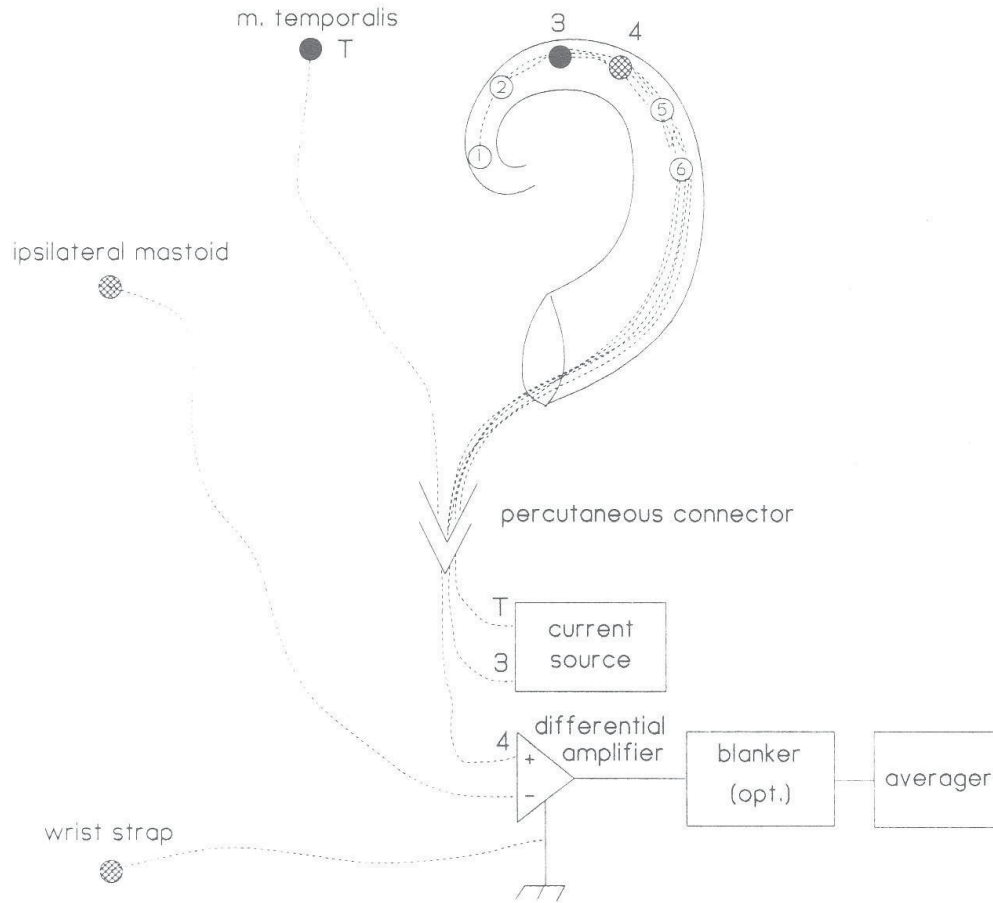

Fig. 2. Apparatus for recording intracochlear evoked potentials

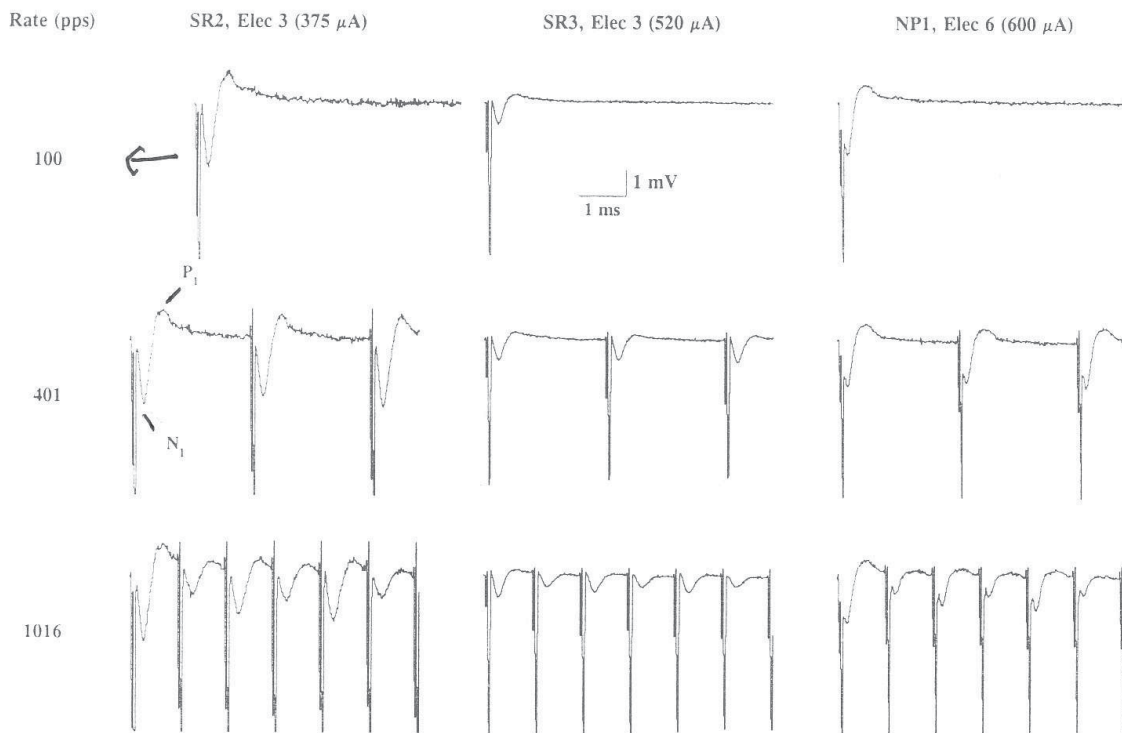

Fig. 3. Intracochlear evoked potentials for subjects SR2, SR3 and NP1. (Figure reprinted from Wilson et al., in press, with permission of the editor for the American Journal of Otology.)

second will have recovered much (but not all) of their initial excitability. More neurons might be expected to respond to the third pulse than to the second. The pattern of alternation between relatively large and relatively small EPs can persist for hundreds of milliseconds at particular rates for a given subject and stimulating electrode (Wilson *et al.*, 1995a).

The magnitudes of EPs and patterns of response across rate of stimulation vary widely across subjects and often across electrodes within subjects (Wilson *et al.*, in press). These differences may reflect differences in refractory properties of the stimulated neurons, the number of neurons participating in the response, subthreshold integration of sequential pulses at neural membranes, and other factors (see Wilson *et al.*, 1994a). Modelling and animal studies are underway at the University of Iowa, our laboratory, and elsewhere, with the aim of developing a quantitative understanding of how various patterns of response to electrical stimuli are produced. Such knowledge may in the near future allow useful inferences from EP recordings about the condition of the auditory nerve in implanted patients on an electrode-by-electrode basis.

Development of back telemetry systems

One of the principal limitations of EP recordings to date is the need for percutaneous access to the implanted electrodes. Various efforts are in progress to develop back telemetry systems that might support recordings with implant devices using transcutaneous links (e.g. Abbas *et al.*, 1997). Useful recordings, for clinically relevant pulse amplitudes and for all patients, will require microvolt sensitivity of the recording amplifier, rapid recovery of the amplifier from saturation, and high resolutions of sampling both in amplitude (e.g. 16 bits) and time (e.g. a sampling rate of 50 kHz). To the extent that these requirements can be fulfilled with a back telemetry system, the likely benefits of EP recordings may be extended to a relatively large number of patients. At present only several hundred users of the Ineraid device, along with a handful of patients implanted with the experimental version of the Nucleus device, have percutaneous access to the electrodes. Manufacture of the Ineraid device has been discontinued. Widespread use of EP recordings in the future will depend on development of an adequate back telemetry system.

Neural representations of modulated pulse trains

A majority of the processing strategies in current clinical use, including the SPEAK and CIS strategies, employ modulated pulse trains as stimuli. To obtain information on how such stimuli are represented in the population responses of the auditory nerve, we have recorded intracochlear EPs for sinusoidally amplitude modulated (SAM) pulse trains with seven subjects and with wide ranges of modulation frequencies and carrier rates.

A representative set of results for carrier rates at and below approximately 1000 pulses/s is presented in Fig. 4 (exact carrier rates and modulation frequencies are indicated in the caption to Fig. 4). The stimuli in this case were delivered to monopolar electrode 3 in subject SR3's Ineraid implant, and the responses were recorded with monopolar electrode 4. The carrier level was adjusted to produce a most comfortable loudness (MCL) percept for 400 Hz modulation of a 1000 pulses/s carrier (bottom right condition in Fig. 4). This level was held constant across all conditions, producing somewhat lower loudnesses for the remaining modulation frequencies for the 1000 pulses/s carrier and for all conditions with the 500 and 250 pulses/s carriers.

The amplitudes of the stimulus pulses for each condition are indicated by solid diamonds and the magnitudes of the EPs following each pulse by connected open squares. The pulse amplitudes are normalized to the maximum amplitude across all conditions, and the EP magnitudes are normalized to the maximum magnitude across all conditions. The peak amplitude was 600 μ A and the pulse duration was 33 μ s/phase. While only the first 20 ms are shown in Fig. 4, the duration of each SAM pulse train was 200 ms.

The patterns of responses appear to reflect both sampling of the modulation waveform by the carrier pulses and the nonlinear properties of auditory neurons. Examples of apparent refractory effects may be seen in the panels for 100 Hz modulation of the 500 and 1000 pulses/s carriers. The third and fourth pulses for the 500 pulses/s carrier have identical amplitudes and yet the neural response to the fourth pulse is substantially lower. For the 1000 pulses/s carrier the sixth pulse is higher in amplitude than the fifth pulse and yet the neural response to the second of those two pulses is again lower in magnitude.

Note also that when the modulation frequency is low compared to the carrier rate the pattern of

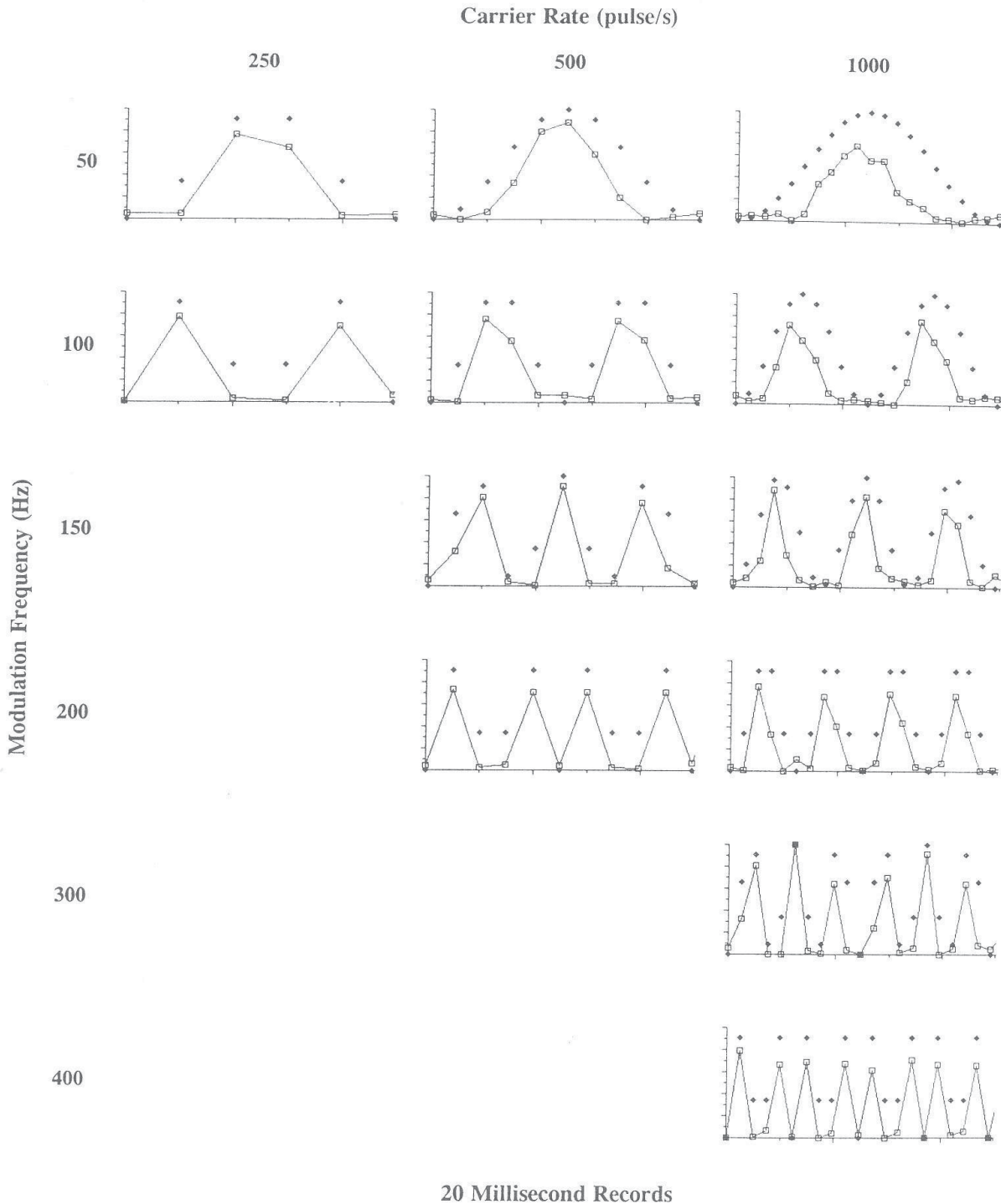

Fig. 4. Pulse amplitudes (filled diamonds) and evoked potential magnitudes (connected open squares) for sinusoidally amplitude modulated (SAM) pulse trains. Normalized values are shown for both measures, with a value of 1.0 corresponding to the maximum pulse amplitude or maximum EP magnitude across all conditions. The stimuli were generated by modulating 250, 500 and 1000 pulses/s carriers at the indicated frequencies. The carrier rates were adjusted slightly to achieve uniform intervals between pulses with a 16.4 μ s sampling interval. The adjusted rates were 251, 504 and 1016 pulses/s. The adjustments also scaled the modulation frequencies; the frequencies for the 251 pulses carrier remained at 50 and 100 Hz, whereas the frequencies for the 504 pulses/s carrier were 50, 101, 151 and 202 Hz, and the frequencies for the 1016 pulses/s carrier were 51, 102, 152, 203, 305 and 407 Hz. Data are from studies with subject SR3.

EP magnitudes approximates the pattern of pulse amplitudes. For 50 Hz modulation of the 500 pulses/s carrier, for example, the pattern of neural responses looks almost sinusoidal, with a somewhat closer approximation to the stimulus pulses in the first half of the modulation cycle. As the modulation frequency is increased, the asymmetry of responses in each modulation cycle increases. For 100 Hz modulation of the 500 pulses/s carrier, for example, a 'peaking' of the responses is observed in the first half of each modulation cycle.

Further increases in modulation frequency produce more complex patterns of responses. The pattern of responses for 150 Hz modulation of the 500 pulses/s carrier reflects the overall frequency of modulation but also shows large variations from cycle to cycle. The 'sampling' of the sinusoidal modulation waveform becomes progressively more sparse with increases in modulation frequency. The sparse sampling for the 150 Hz modulation condition only crudely reflects the modulation waveform. As the modulation frequency approaches one half the carrier rate (the 'Nyquist frequency' see Rabiner and Schafer, 1978), multiple intervals and other anomalies can appear in the stimuli and in the patterns of responses. Multiple intervals appear, for example, in the stimuli and pattern of responses for 200 Hz modulation of the 500 pulses/s carrier. The time between peaks in the response alternates between long (6 ms) and short (4 ms) intervals. Neither of these intervals corresponds to the period of the modulation waveform (5 ms).

The effects just described for the 500 pulses/s conditions scale with carrier rate. For the 1000 pulses/s carrier, for example, a highly complex pattern of responses is observed at the modulation frequency of 300 Hz, and a pattern of responses with two distinct intervals is observed at the modulation frequency of 400 Hz. For the 250 pulses/s carrier, two distinct intervals are observed in the pattern of responses at the modulation frequency of 100 Hz, although the 20 ms segment of the record presented in Fig. 4 is too short to show both intervals for this particular condition.

Percepts reported by subjects SR2 and SR3 when listening to these stimuli are consistent with the recorded patterns of responses. For the 500 pulses/s carrier conditions, the subjects report increases in pitch with increases in modulation

frequency. The percepts elicited with relatively low modulation frequencies are described as smooth and tonal. However, the percept for the 150 Hz modulation condition is described as sounding rough and complex. Also, the percept for the 200 Hz modulation condition is described as combining at least two separate tones. For the 1000 pulses/s carriers, the percepts for the 150 and 200 Hz modulation conditions are described as relatively smooth and tonal, particularly the percept for the 200 Hz modulation condition. The percepts for the two lower modulation frequencies also are described as smooth and tonal, as before. For the higher modulation frequencies, however, a rough and complex percept is again reported, but this time at the modulation frequency of 300 Hz, and a multitonal percept is again reported, but this time at the modulation frequency of 400 Hz. These reports for the higher carrier rate are consistent with the scaling of neural response patterns with changes in carrier rate, as described above.

In broad terms, the results of Fig. 4 suggest that the carrier rate in CIS and other processors should be 4 to 5 times the highest frequency in the modulation waveforms for a smooth and unambiguous representation of those waveforms. Busby *et al.* (1993) have offered this same suggestion, based on results from their psychophysical studies with patients using the Nucleus device.

Additional studies have been conducted with several subjects to evaluate effects of even higher carrier rates on neural representations of modulation waveforms (Wilson *et al.*, 1996). A representative set of results is presented in Fig. 5. The stimuli were delivered to monopolar electrode 3 in subject SR2's Ineraid implant, and the responses were recorded with monopolar electrode 4. The carrier level across all conditions was 475 μ A. The pulse duration was 33 μ s/phase.

The comparison in Fig. 5 is between carrier rates of 1016 pulses/s and 4065 pulses/s, for the modulation frequencies of 100, 200, 300, 400, 500 and 600 Hz. Note that the combinations of carrier rate and modulation frequencies are somewhat different from those of the corresponding conditions in Fig. 4 (see caption to Fig. 4). Note also that 30 ms records are presented in Fig. 5, rather than the 20 ms records found in Fig. 4. The EP magnitudes in Fig. 5 are normalized to the maximum magnitude across all conditions.

Results for the 1016 pulses/s carrier show simple representations of the modulation frequency

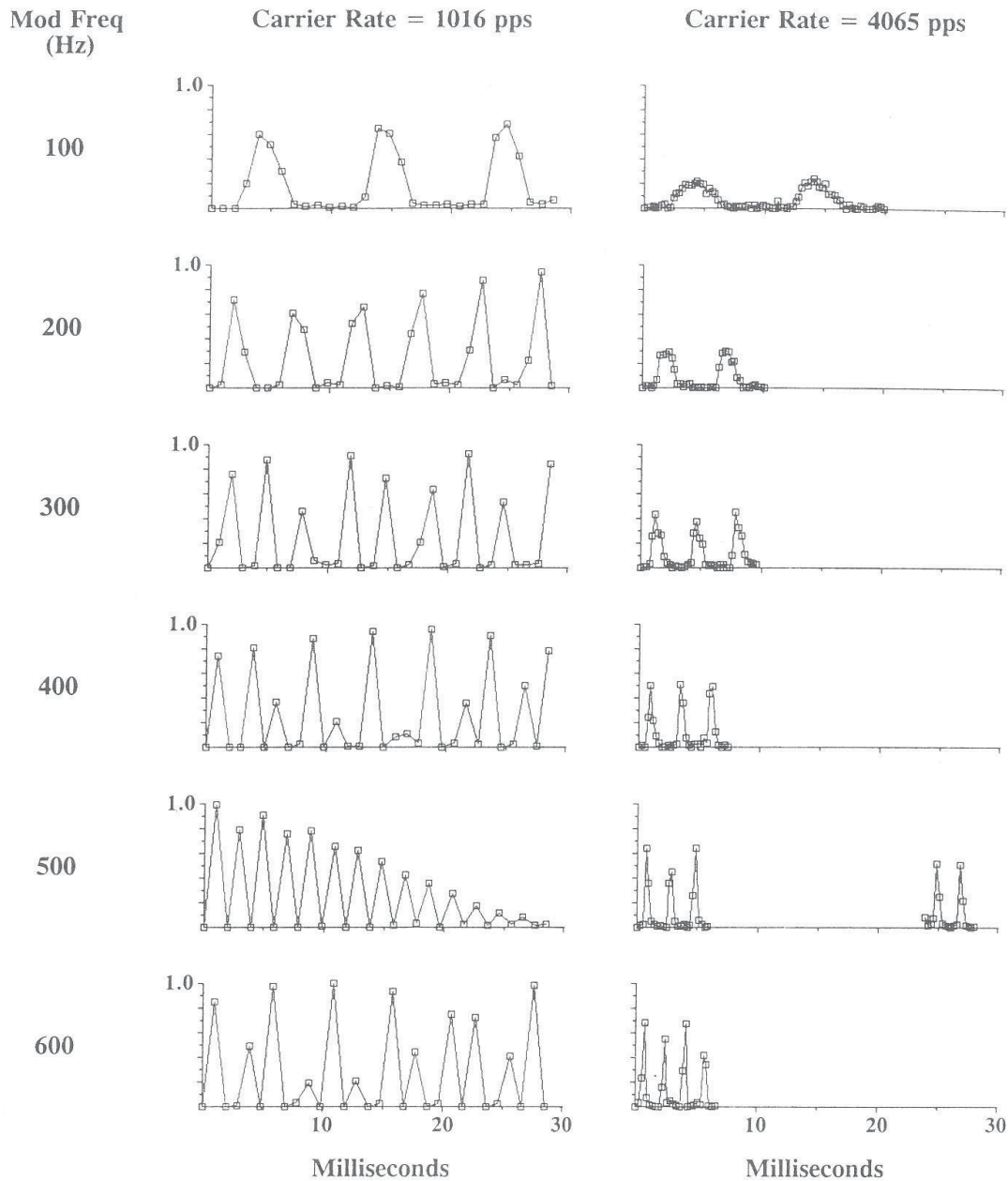

Fig. 5. Evoked potential magnitudes for SAM pulse trains with the carrier rates of 1016 and 4065 pulses/s. EP magnitudes are normalized to the maximum value across all conditions. The modulation frequencies used in the studies of this figure are somewhat different from those used in the studies of Fig. 4 and are exact for all conditions. Responses for the high rate carrier were derived using a subtraction technique to remove the influence of all prior stimuli (and responses thereto) from the response to the final pulse in a train (see Wilson et al., in press). That is, the response to the N th pulse was derived by subtracting a record for an $N-1$ pulse train from a record for an N pulse train, leaving only the response to the N th pulse. Without such subtraction, prior EPs would overlap because the approximately 1 ms duration of an EP waveform (see Fig. 3) is greater than the interval between sequential pulses (and EPs) for pulse rates greater than about 1000/s. Data are from studies with subject SR2.

for the 100 and 200 Hz modulation conditions. The pattern of responses becomes more complicated at a modulation frequency of 300 Hz. At 400 Hz the pattern is both complicated and no longer reflects the period of the modulation waveform. The first interval between major peaks in the response (between pulses 2 and 5) roughly approximates the period, but subsequent intervals are much longer than the period. (The difference between this pattern of responses and the pattern for the corresponding condition in Fig. 4 is consistent with the slight difference in the combinations of modulation frequency and carrier rate.)

Close approximation of the modulation frequency to the Nyquist frequency, as with the 500 Hz modulation condition, produces a pattern of stimulation in which pulses of relatively high amplitudes alternate with pulses of relatively low amplitudes. The difference between high and low amplitude pulses wanes and waxes at a 'beat frequency' equal to the difference between the modulation and Nyquist frequencies, in this case 8 Hz. Modulation precisely at the Nyquist frequency would produce a series of alternating pulses with fixed amplitudes at high and low levels, the levels depending on the fixed phase offset between the pulses and the modulation waveform.

The pattern of responses in Fig. 5 for 500 Hz modulation of the 1016 pulses/s carrier reflects the pattern of stimulation, i.e., alternating high and low EP magnitudes with the difference in high and low magnitudes diminishing over the half-period of the 8 Hz beat frequency. In addition, the response to pulse 4 is low compared to the response to pulse 2, and the response to pulse 8 is low compared to the response to pulse 6. This latter pattern probably reflects refractory properties of the neurons, as discussed in connection with Figs. 3 and 4.

When the modulation frequency exceeds the Nyquist frequency a phenomenon called 'aliasing' occurs, in which the pattern of stimulation for a given modulation frequency above the Nyquist frequency is identical (except for a possible phase offset) to the pattern that would be obtained for a modulation frequency below the Nyquist frequency by an equal amount. For example, with a 1000 pulses/s carrier identical patterns of stimulation would be produced with modulation frequencies of 400 and 600 Hz (the pattern resulting from aliasing by the 600 Hz modulation is like the uncorrupted pattern produced by 400 Hz modulation).

For the present conditions the 400 and 600 Hz modulation frequencies are not quite equally distant from the Nyquist frequency (508 Hz). However, they are close enough to produce similarities in the patterns of stimulation and responses. A complicated pattern of response is again observed for the 600 Hz modulation condition, that does not reflect the frequency of the modulation waveform.

Three regions of responses can be identified for the 1016 pulses/s carrier. At relatively low modulation frequencies, i.e., 100 and 200 Hz, the responses simply represent the modulation waveform. At somewhat higher modulation frequencies complex patterns of response are observed. Those patterns do not correspond to any details of the modulation waveform and, indeed, at the modulation frequency of 400 Hz do not represent the modulation frequency. Severe sampling artifacts occur as the Nyquist frequency is approximated or exceeded by the modulation frequency. Results of such artifacts can be seen in the patterns of responses for the 500 and 600 Hz modulation conditions.

Patterns of responses for the 4065 pulses/s carrier show simple representations for all modulation frequencies included in the studies of Fig. 5 (responses for the high rate carrier were derived using a subtraction technique described in the caption to Fig. 5). The patterns of responses follow closely the patterns of stimulation for the modulation frequencies of 400 Hz and lower. The distortions noted before for 300 and 400 Hz modulation of the 1016 pulses/s carrier are eliminated with an increase in carrier rate to 4065 pulses/s. At the higher modulation frequencies of 500 and 600 Hz, the patterns of responses for the 4065 pulses/s carrier show a shallow alternation between high and low peaks for successive cycles of the modulation waveform. For the 500 Hz condition this alternation may be damped or absent after the initial cycles, as suggested by the pattern of responses for two cycles beginning about 24 ms after the onset of the burst.

Additional aspects of the responses for the 4065 pulses/s carrier are that (a) the peak magnitudes are lower than those for the 1016 pulses/s carrier and (b) the responses from pulse to pulse are smooth and continuous within modulation cycles. These aspects are consistent with the idea that high rate stimuli elicit a more stochastic pattern of responses within and among neurons than low rate stimuli (Wilson *et al.*, 1994a; in press).

When pulses are presented at high rates, low levels of neural membrane noise at nodes of Ranvier may interact with the pulses to produce stochastic independence among neurons. Slight variations in neural threshold due to membrane noise may introduce a 'jitter' in firing times across neurons for rapidly presented pulses. The effect of such jitter would be expected to increase with time after the beginning of a train of pulses, as initially small differences in discharge histories among neurons increased. After a relatively short period, differences in discharge histories may produce a high level of stochastic independence among neurons.

Such a mechanism would allow different subpopulations of neurons in the excitation field to respond to sequential pulses and thereby share the load in representing temporal variations in the modulation waveform. The total number of neurons responding to any one pulse would in general be small compared to the number stimulated by single pulses at low rates of stimulation. Thus, one might expect relatively small EPs for high rates in conjunction with relatively smooth and continuous patterns of responses within modulation cycles. The aggregate of all neural discharges in single cycles would be roughly the same for low and high carrier rates; only the distribution in time of the discharges within the cycles would be different.

In normal hearing neurons exhibit spontaneous activity, produced by random release of chemical transmitter quanta into the synaptic clefts between inner hair cells and adjacent neurons, even in the absence of acoustic stimulation. This spontaneous activity is not correlated, and results in randomized discharge histories among the neurons. These factors may underlie the observed stochastic independence among fibers of the auditory nerve in normal hearing (Johnson and Kiang, 1976). Such independence may be important in representing high frequency information in the population responses of the nerve (see also Parnas, 1996, and Figure 8 and the accompanying discussion in Wilson *et al.*, 1994a).

Spontaneous activity is absent in the auditory nerves of deafened animals (Hartmann *et al.*, 1984). However, a relatively low level of noise remains at nodes of Ranvier in surviving neurons. This level is insufficient to produce spontaneous discharges, but may be sufficient for a fortuitous interaction with pulses presented at high rates by cochlear implants.

Perception of modulated pulse trains

Findings from recordings of intracochlear EPs led us to measure effects of carrier rate on psychophysical scaling of modulation frequencies. Results for subject SR2 are presented in Fig. 6 (Wilson and Zerbi, unpublished observations). Electrode 3 was stimulated at MCL levels for all stimuli, which included 200 ms bursts of both SAM and unmodulated pulses. Six conditions were studied for each of five carrier rates and for the unmodulated pulse trains. The conditions for the SAM pulse trains included 100 percent modulation at frequencies of 100 through 600 Hz at 100 Hz intervals. The conditions for the unmodulated pulse trains included the corresponding pulse rates of 100 through 600/s. Separate scaling experiments were conducted for each of the carrier rates and for the unmodulated pulse trains. The amplitudes of the stimuli were adjusted prior to each experiment as necessary to eliminate any differences in loudness across conditions. The subject was instructed to assign a number between 0 and 100 for each stimulus in the experiment according to perceived pitch. Thirty stimuli were presented in random order for each condition in the experiments involving the unmodulated pulses and the carrier rates of 2032, 5081 and 10162 pulses/s. Sixty stimuli were presented for each condition in the experiments involving the carrier rates of 503 and 1016 pulses/s.

Fig. 6 shows the means and standard errors of the means of the judgments for each of the six conditions within the six experiments. As expected from the prior EP recordings, carrier rate influenced the range over which pitch increased monotonically with increases in modulation frequency. For the 1016 pulses/s carrier, increases in modulation frequency beyond 300 Hz did not produce monotonic increases in pitch. In fact, judged pitch is not statistically different for the 200, 400 and 600 Hz modulation conditions. This is consistent with a predominance of 5 ms intervals between major peaks in the neural response patterns for these conditions, as shown in the left column of Fig. 5. The judgment for 500 Hz modulation is substantially higher than the judgment for all other conditions. This again is consistent with the pattern of neural responses, which shows peaks separated by 2 ms. The increases in pitch up to the modulation frequency of 300 Hz may correspond to a progressive reduction in the intervals between principal peaks in the neural response patterns as the frequency is increased from 100 to 300 Hz.

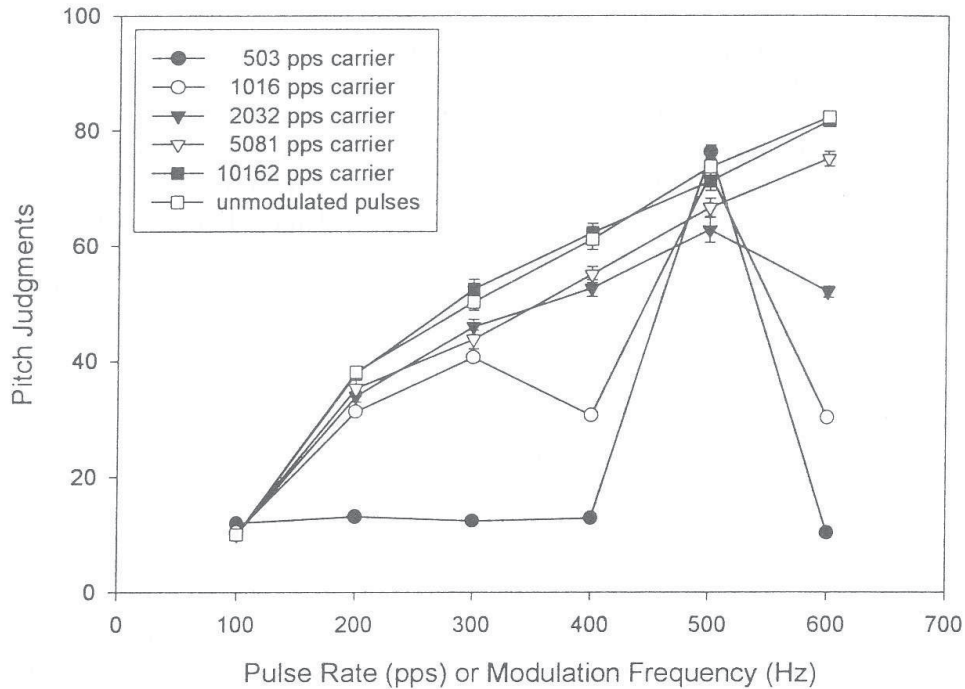

Fig. 6. Scaling of pulse rate for unmodulated pulse trains and of modulation frequency for SAM pulse trains. Data are from studies with subject SR2.

Judgments for the 503 pulses/s carrier are highly similar for the modulation frequencies of 100, 200, 300, 400 and 600 Hz. In fact, the judgments for the lower four frequencies are statistically identical. Although this result may seem curious at first sight, plots of the stimuli show that each of these particular combinations of modulation frequency and carrier rate produce a predominance of 10 ms intervals between major peaks.

The judgment for the 500 Hz modulation condition and the 503 pulses/s carrier shows a large increase in pitch compared with the judgments for the other modulation conditions. The close approximation of the modulation frequency to the carrier rate produces peaks in the stimuli at 2 ms intervals.

Pitch increases monotonically with increases in modulation frequency up to 500 Hz for the 2032 pulses/s carrier. Pitch is reduced for the 600 Hz modulation condition, and this judgment does not differ significantly from the judgment for the 400 Hz modulation condition.

For higher carrier rates, and for unmodulated pulses, pitch scales monotonically with increases in modulation frequency or pulse rate, respectively. The range of pitch judgments is greatest for the highest carrier rate and for the unmodulated pulses.

Development of high rate processors

Results like those of Fig. 6 show that increases in carrier rate can increase the range over which increases in modulation frequency produce monotonic increases in pitch. The question now is whether access to a greater range of pitches on single channels will be helpful in multichannel processors. One concern is that temporal channel interactions, due to summation at neural membranes of rapidly presented pulses from different electrodes, may be exacerbated with increased rates of stimulation. Such interactions may limit possible benefits of high rate stimuli. On the other hand, control or reduction of temporal channel interactions might remove this potential limitation. Work is in progress to develop novel stimulus waveforms specifically designed to leave neural membranes at their resting potential after delivery of a subthreshold pulse (e.g. Eddington *et al.*, 1994). In this way, effects of sequential subthreshold pulses (from different electrodes) would not accumulate and cause an unwanted discharge of the neuron. In addition, parallel developments of new electrode designs may produce an electrode system with greater spatial specificity of stimulation and reduced interactions among electrodes compared to present designs (see section on new electrode

designs below). Use of such electrodes may reduce or eliminate the concern about temporal channel interactions.

Implementation of high rate processors with multiple channels is technically demanding. Delivery of high rate stimuli within and across electrodes requires high bandwidth current sources capable of generating pulses with durations of 10 μ s/phase or less. Also, for percutaneous connector systems, capacitive coupling among the leads in the cable to the connector can produce 'crosstalk' among channels for high frequency, high rate stimuli. New equipment has been developed in our laboratory and at the Massachusetts Eye and Ear Infirmary to support evaluations of high rate processors. In our system, for example, each of 24 current sources can generate pulses with phase durations as short as 5 μ s, and capacitive crosstalk among the leads to percutaneous connectors has been reduced to insignificant levels through the use of 'driven' shields for each of the leads. Results from the initial studies in our laboratory should be available before the end of 1997.

As noted above, the recent studies of Brill *et al.* (in press), Brill and Hochmair (1997), and Kiefer *et al.* (1996; 1997) have provided some preliminary indications of improved speech reception scores with high rate stimuli. In the near future we should know whether further improvements can be obtained with combinations of numbers of channels and rates of stimulation that exceed the capabilities of the Combi 40 and Combi 40+ devices, the fastest implant systems that are commercially available at this time. In addition, further improvements may be obtained through different choices of processor parameters, such as an increase in the cutoff frequency of the low-pass filters in the envelope detectors of CIS processors, to make available to patients higher frequencies in the modulation waveforms.

Stochastic effects

Possible advantages of stochastic independence among neurons have already been mentioned in the context of neural representations of modulated pulse trains. Obtaining such independence through the use of stimulus rates greatly in excess of the maximum discharge rate of single neurons was discussed. An alternative method might be to present noise with deterministic stimuli (Morse and Evans, 1996; Moss *et al.*, 1996). If the exogenous noise approximates the level of noise at

nodes of Ranvier, then a favourable interaction may occur between the external and internal noise, in which the external noise 'amplifies' effects of the internal noise. The waveform of the exogenous noise would of course be perfectly correlated across nodes and neurons and by itself would not contribute to stochastic independence among neurons. The interaction would be expected to occur over a relatively narrow range of amplitudes for the external noise. Such effects have been described by Morse and Evans. They have observed large improvements in the ability of a sciatic nerve preparation (used as a model of the auditory nerve) to represent high frequency information in population responses when exogenous noise is presented with deterministic stimuli and when the level of the exogenous noise is within a narrow range of amplitudes.

Application of exogenous noise may be helpful for implant patients. Studies need to be conducted to demonstrate possible amplitude ranges over which benefits might be produced, and whether such effects, if present for the auditory nerve, are the same or different across different types of deterministic stimuli, different patients, and different electrodes within a patient.

Still other possibilities for exploiting or enhancing the effects of neural membrane noise are under investigation (e.g. Wilson *et al.*, 1994b), including use of long duration pulses or analog stimuli, use of particular pulse intervals, use of pulse duration modulation instead of pulse amplitude modulation, and use of irregular timing for carrier pulses. The use of long enough pulse durations, for instance, might involve pulse amplitudes comparable to noise levels at nodes of Ranvier, enabling favourable interactions between stimuli and membrane noise.

Replication of normal hair cell/neuron dynamics

As indicated by recordings of intracochlear EPs for SAM pulse trains (e.g., the recordings presented in the right column of Fig. 5), use of high carrier rates can simplify the representation of modulation waveforms in the patterns of auditory nerve responses. Results of psychophysical studies show that such changes in the neural representations are accompanied by changes in perception, e.g. pitch is scaled monotonically over a greater range of modulation frequencies.

The higher level of neural control provided by high rate carrier pulses might be exploited to represent more complex and more realistic

modulation signals. The modulation signal used for present CIS processors is a simple estimate of the envelope at the output of each bandpass filter. The estimate is derived using a rectifier followed by a lowpass filter. A better estimate might be provided with a Hilbert transform (see Oppenheim and Schaffer, 1975), a much more complicated signal processing technique. The relatively subtle differences in the envelopes derived from the better estimation technique might be conveyed with the use of high carrier rates.

Use of high carrier rates also may allow representation of envelope signals that mimic the non-instantaneous compression functions found in normal hearing at the synapses between inner hair cells and adjacent fibers of the auditory nerve. Models of these functions for normal hearing (e.g. Meddis, 1986) could be substituted for the envelope detectors (and mapping tables for conversion of envelope levels to pulse amplitudes) in CIS processors. It may be possible to convey the subtleties and rapid variations in signals derived with such models through the use of high carrier rates.

New electrode designs

As mentioned above, placement of electrodes next to the inner wall of the scala tympani may provide several benefits, including increased spatial specificity of stimulation, reduced thresholds, and increased dynamic ranges. Work is in progress at several companies and academic institutions to achieve such placement in a safe and repeatable way. In one approach (Seldon *et al.*, 1994; Kuzma *et al.*, 1996), for example, a material that expands when exposed to water would be fixed to one side of an electrode carrier. After insertion of the carrier into the scala tympani, the material would be exposed to perilymph and expand, forcing the attached electrode array to assume the curved shape of the inner wall along the cochlear spiral. The expansion also would push the carrier and electrodes toward the inner wall. In another approach (Kuzma, 1996) a flexible rod would be attached to the distal end of the electrode carrier and the parallel carrier and rod implanted together. Once the assembly was implanted, the rod would be pushed gently by the surgeon. It would then arch and force the carrier up against the inner wall. The rod and carrier would be clamped together at the basal end of the assembly after adjustment, to maintain the desired placement.

Such approaches are being evaluated and refined and may lead to large improvements in implant performance. Once achieved, predictably close electrode placement might be exploited through novel speech processor designs and/or through different choices of parameter values for CIS processors. As an example of the latter, a greater spatial specificity of stimulation might increase the utility of a higher number of channels than is the case with present electrode arrays, which produce broadly overlapping fields of stimulation.

Efforts also are underway to increase the number of electrodes in implants. Although only 4–6 electrodes might be used effectively with present placements, the ability to choose those 4–6 from a large number can support significant improvements in speech reception performance, as indicated by the results in Fig. 1. In addition, if the electrodes can be positioned close to the inner wall, then a larger number of active electrodes may become useful. A combination of close placements and high densities of electrodes could lead to especially large gains in performance.

Close placements of many electrodes next to the inner wall also might allow independent or quasi independent control of separate populations of neurons within a critical band distance of each other (i.e. within a distance of approximately 1 mm along the cochlear partition). Critical bands in normal hearing reflect the spatial window over which the central auditory system may integrate inputs from the periphery for a wide variety of judgments and tasks (see, e.g., Moore, 1989). New coding strategies might well exploit this level of control, e.g., to convey high frequency information through shared and coordinated stimulation of two or more populations of neurons within single critical bands (Wilson *et al.*, 1994b).

A new era in speech processor design

Recent advances in the study of intracochlear EPs suggest many exciting possibilities, including tests to assess auditory nerve responses of individual patients on an electrode-by-electrode basis, and refined processor fittings based on such knowledge. The most important benefit, however, may be the ability to develop and verify new processing strategies in terms of observable rather than assumed patterns of neural response. This may represent a new era in design for auditory prostheses, in which the goal is to produce

desired patterns of response at the nerve rather than merely desired patterns of stimulation at the implanted electrodes.

Coordinated bilateral stimulation

Our group has begun studies with a local patient having standard Nucleus implants in both ears. She was deafened as a consequence of Listeria rhomboencephalitis and received a cochlear implant. Bony obstruction of the scala tympani limited the depth of that insertion and, when radiographic studies demonstrated a rapid progression of obstruction bilaterally, a decision was made to proceed at once with implantation of an identical device on the other side, where a full insertion was achieved.

Initial studies with this subject have included psychophysical measures of sensitivity to interaural timing and amplitude differences (Lawson *et al.*, 1996b). The tests were conducted with pairings of electrodes on the two sides that produced identical pitch and loudness percepts when stimulated singly with 50 ms bursts of pulses. The results indicated an ability to identify the ear receiving the earlier signal for timing differences of 150 μ s or less for each of the three tested pairings of electrodes. The sensitivity to a reduction in amplitude for one of the two electrodes in these same pairings was 4 clinical units or better. For one of the pairings the sensitivity was 1 clinical unit, which corresponded to approximately 1/75th of the dynamic range (in terms of equivalent current levels) from threshold to MCL for the electrodes in that pair.

These results are most encouraging in that the measured sensitivity to interaural timing differences is much better than that measured for two bilateral subjects in the studies of van Hoesel *et al.* (1993) and van Hoesel and Clark (1995; 1997). The just noticeable difference in timing exceeded 1 ms for both of those subjects, including jnds for pairings of electrodes on the two sides that provided matches in pitch and loudness. The jnd for subjects with normal hearing ranges from 10 to 80 μ s, depending on the subject and the type of stimulus used (Moore, 1989; Gabriel *et al.*, 1992).

The sensitivity demonstrated by our patient indicates for the first time that interaural timing cues might be exploited in speech processor designs, in which a single processor receives inputs from two microphones and provides coordinated stimulation of two implants. Such stimuli would preserve localization cues and possibly

exploit the larger number of total sites of stimulation provided by the implants in both ears. Good use of bilateral stimulation may provide large improvements in the speech reception abilities of implant patients, especially in environments with high levels of ambient noise and/or multiple talkers.

Work is in progress in our laboratory and elsewhere to evaluate processing strategies for bilateral implants. Our plans include ongoing studies with the patient described above, additional studies of a patient who has full insertions of Combi 40+ implants on both sides, and a series of patients to be implanted at the University of Iowa with CI24M devices on both sides.

Inexpensive yet effective implant systems

Present implant systems are expensive. Their cost prohibits widespread application in many countries. China is an example (Zeng, 1995). That country has a disproportionately large population of profoundly deaf people. A major cause of deafness in China has been frequent use of ototoxic drugs such as streptomycin.

The predicament of China and other countries is that the number of people who might benefit from an implant is high and yet resources are not available to support the present cost of the devices for even a tiny fraction of that population. This has inspired the development of low cost systems that nonetheless provide high levels of speech reception performance (e.g. Wilson *et al.*, in press). A principal goal has been to choose technologies and approaches that are compatible with manufacture of the systems in the country of application. This can reduce substantially the cost of manufacture and, for some countries, eliminate or reduce regulatory, marketing and other costs associated with manufacture of devices in Western countries. Costs of surgery and subsequent medical care also can be much lower in China and other countries compared to Western countries. The combination of these favorable factors may allow treatment of a large number of deaf people with affordable yet effective implant systems.

Criteria for implantation

The recent improvements in the speech reception performance of cochlear implant systems have motivated changes in criteria for implantation, to include as candidates people who have some residual hearing. Expected performance

with implants now exceeds expected performance with hearing aids for people with severe hearing loss. Further improvements in implant design and performance are likely to lead to further relaxation in the criteria for implantation. Given the demographics of the hearing impaired population, even a slight relaxation in the present criteria would increase substantially the number of candidates for implants.

Conclusions

I believe that we are at an exciting point in the development of cochlear prostheses, with many possibilities for improved performance. Design and application of new processing strategies have produced dramatic improvements in the past, and I expect that such work will produce dramatic improvements in the future, especially for patients presently at the low end of the performance spectrum. I also expect that informed use of intracochlear evoked potentials will transform the field of cochlear prostheses, in allowing development of processing strategies that produce specific patterns of responses in the auditory nerve of implant patients, and in providing information on the stimulus/response characteristics of intracochlear electrical stimulation across patients and across electrodes within a patient. Such information could be used for better fitting of speech processors to the individual and perhaps for understanding the bases of the remaining variability in outcomes across patients. Use of new types of electrodes, in conjunction with processing strategies specifically designed to exploit the new features and capabilities of those electrodes, may well lead to quantum jumps in the speech reception performance of implant patients. Coordinated stimulation of the two sides for recipients of bilateral implants may restore sound localization abilities and the signal-to-noise advantages supported by such abilities. Bilateral implants also may be used to increase the number of perceptually distinct sites of stimulation for the recipients. Modeling studies, when combined with EP measures, have the potential for providing deep insights into the mechanisms underlying auditory nerve responses to intracochlear electrical stimulation. Such insights could provide a foundation for further improvements in electrode and speech processor designs. If the past is a guide, continued increases in the speech reception performance of cochlear implants will lead to continued revisions in the criteria for candidacy. This, along with

development of inexpensive implant systems, likely will expand dramatically the number of patients receiving implants in the years ahead.

Acknowledgments

Preparation of this editorial was supported by NIH project N01-DC-9-2103. Many of the suggestions and ideas presented here are the result of enlightening discussions with colleagues. I also owe a great debt of gratitude to the subjects of our studies. Their generosity and pioneering spirit have made our research possible. Parts of this editorial were presented in invited lectures at the Third European Symposium on Paediatric Cochlear Implantation, held in Hannover, Germany, June 6–8, 1996, and at the Vth International Cochlear Implant Conference, held in New York City, May 1–3, 1997. I am grateful to Dewey Lawson for his insightful editorial assistance.

References

- Abbas PJ, Brown CJ, Dillier N, Lai WK, Heller J. Measures of the electrically evoked whole nerve action potential using the Nucleus CI24M cochlear implant. Presented at the Vth International Cochlear Implant Conference, New York, NY, May, 1997.
- Battmer R-D, Gupta SP, Allum-Mecklenburg D, Lenarz T. Factors influencing cochlear implant perceptual performance in 132 adults. *Ann Otol Rhinol Laryngol* 1995; 104 (Suppl 166): 185–187.
- Blamey PJ, Arndt P, Bergeron F, Bredberg G, Brimacombe J, Facer G, Larky J, Lindström B, Nedzelski J, Peterson A, Shipp D, Staller S, Whitford L. Factors affecting auditory performance of postlinguistically deaf adults using cochlear implants. *Audiol Neurootol* 1996; 1: 293–306.
- Blamey PJ, Pyman BC, Gordon M, Clark GM, Brown AM, Dowell RC, Hollow RD. Factors predicting postoperative sentence scores in postlinguistically deaf adult cochlear implant patients. *Ann Otol Rhinol Laryngol* 1992; 101: 342–348.
- Brill S, Gstöttner W, Helms J, von Ilberg C, Baumgartner W, Müller J, Kiefer J. Optimization of channel number and stimulation rate for the fast CIS-strategy in the COMBI 40+. *Am J Otol*, in press.
- Brill S, Hochmair ES. Speech understanding as a function of the number of active channels and

- stimulation rate in the CIS strategy as implemented in the Combi 40/Combi 40+. Presented at the Vth International Cochlear Implant Conference, New York, NY, May, 1997.
- Brown CJ, Abbas PJ, Borland J, Bertschy MR. Electrically evoked whole nerve action potentials in Ineraid cochlear implant users: Responses to different stimulating electrode configurations and comparison to psychophysical responses. *J Speech Hear Res* 1996; 39: 453-467.
- Brown CJ, Abbas PJ, Gantz B. Electrically evoked whole-nerve action potentials: Data from human cochlear implant users. *J Acoust Soc Am* 1990; 88: 1385-1391.
- Busby PA, Tong YC, Clark GM. The perception of temporal modulations by cochlear implant patients. *J Acoust Soc Am* 1993; 94: 124-131.
- Dorman MF, Hannley MT, Dankowski K, Smith L, McCandless G. Word recognition by 50 patients fitted with the Symbion multichannel cochlear implant. *Ear Hear* 1989; 10: 44-49.
- Fishman K, Shannon RV, Slattery WH. Speech recognition as a function of the number of electrodes used in the SPEAK cochlear implant speech processor. *J Speech Hear Res*, in press.
- Eddington DK, Runbinstein JT, Dynes SBC. Forward masking during intracochlear electrical stimulation: Models, physiology, and psychophysics. *J Acoust Soc Am* 1994; 95: 2904.
- Flanagan JL. *Speech analysis, synthesis and perception*. New York: Springer-Verlag, 1972.
- Gabriel KB, Koehnke J, Colburn HS. Frequency dependence of binaural performance in listeners with impaired binaural hearing. *J Acoust Soc Am* 1992; 91: 336-347.
- Gantz BJ, Woodworth GG, Abbas PJ, Knutson JF, Tyler RS. Multivariate predictors of audiological success with multichannel cochlear implants. *Ann Otol Rhinol Laryngol* 1993; 102: 909-916.
- Hartmann R, Topp G, Klinke R. Discharge patterns of cat primary auditory nerve fibers with electrical stimulation of the cochlea. *Hear Res* 1984; 13: 47-62.
- Hill FJ, McRae P, McClellan RP. Speech recognition as a function of channel capacity in a discrete set of channels. *J Acoust Soc Am* 1968; 44: 13-18.
- Johnson DH, Kiang NYS. Analysis of discharges recorded simultaneously from pairs of auditory nerve fibers. *Biophysical J* 1976; 16: 719-734.
- Kiefer J, Pfennigdorff T, Rupperecht V, Huber-Egener J, von Ilberg C. The effect of stimulus rate and channel number on speech understanding with the CIS-strategy in cochlear implant patients. Presented at the Third European Symposium on Paediatric Cochlear Implantation, Hannover, Germany, June, 1996.
- Kiefer J, von Ilberg C, Rupperecht V, Huber-Egener J, Baumgartner W, Gstöttner W, Stephan K. Optimized speech understanding with the CIS-speech coding strategy in cochlear implants: The effect of variations in stimulus rate and numbers of channels. Presented at the Vth International Cochlear Implant Conference, New York, NY, May, 1997.
- Kileny PR. Use of electrophysiological measures in the management of children with cochlear implants: Brainstem, middle latency, and cognitive (P300) responses. *Am J Otol* 1991; 12 (Suppl 1): 37-42.
- Kileny PR, Zimmerman-Philips S, Kemink JL, Schmaltz SP. Effects of preoperative electrical stimulability and historical factors on performance with multichannel cochlear implant. *Ann Otol Rhinol Laryngol* 1991; 100: 563-568.
- Knutson JF, Hinrichs JV, Tyler RS, Gantz BJ, Schartz HA, Woodworth G. Psychological predictors of audiological outcomes of multichannel cochlear implants: Preliminary findings. *Ann Otol Rhinol Laryngol* 1991; 100: 817-822.
- Kraus N, McGee T, Carrell TD, Sharma A. Neurophysiologic bases of speech discrimination. *Ear Hear* 1995; 16: 19-37.
- Kuzma JA. Cochlear electrode implant assemblies with positioning system therefor. US patent 5545219, Aug. 13, 1996.
- Kuzma JA, Seldon HL, Brown GG. Self-curving cochlear electrode array. US patent 5578084, Nov. 26, 1996.
- Lawson DT, Wilson BS, Finley CC. New processing strategies for multichannel cochlear prostheses. *Prog Brain Res* 1993; 97: 313-321.
- Lawson DT, Wilson BS, Zerbi M, Finley CC. Speech processors for auditory prostheses. Third Quarterly Progress Report, NIH project N01-DC-5-2103. Neural Prosthesis Program, National Institutes of Health, Bethesda, MD, 1996a.
- Lawson DT, Wilson BS, Zerbi M, Finley CC. Speech processors for auditory prostheses. Fifth Quarterly Progress Report, NIH project

- N01-DC-5-2103. Neural Prosthesis Program, National Institutes of Health, Bethesda, MD, 1996b.
- McDermott HJ, McKay CM, Vandali AE. A new portable sound processor for the University of Melbourne/Nucleus Limited multielectrode cochlear implant. *J Acoust Soc Am* 1992; 91: 3367-3391.
- McDermott HJ, Vandali AE. Spectral maxima sound processor. US patent 5597380, Jan. 28, 1997.
- Meddis R. Simulation of mechanical to neural transduction in the auditory receptor. *J Acoust Soc Am* 1986; 79: 702-711.
- Micco AG, Kraus N, Koch DB, McGee TJ, Carrell TD, Sharma A, Nicol T, Wiet RJ. Speech-evoked cognitive P300 potentials in cochlear implant recipients. *Am J Otol* 1995; 16: 514-520.
- Moore BCJ. An introduction to the psychology of hearing 3rd edn. London: Academic Press, 1989.
- Morse RP, Evans EF. Enhancement of vowel coding for cochlear implants by addition of noise. *Nature Med* 1996; 2: 928-932.
- Moss F, Chioutan F, Klinke R. Will there be noise in their ears? *Nature Med* 1996; 2: 860-862.
- NIH Consensus Statement. Cochlear implants in adults and children, May 15-17, 1995. (reproduced in *JAMA* 1995; 274: 1955-1961.)
- Oppenheim AV, Schaffer RW. Digital signal processing. Englewood Cliffs, NJ: Prentice-Hall, 1975.
- Parkins CW. Temporal response patterns of auditory nerve fibers to electrical stimulation in deafened squirrel monkeys. *Hear Res* 1989; 41: 137-168.
- Parnas BR. Noise and neuronal populations conspire to encode simple waveforms reliably. *IEEE Trans Biomed Eng* 1996; 43: 313-318.
- Ponton CW, Don M. The mismatch negativity in cochlear implant users. *Ear Hear* 1995; 16: 131-146.
- Rabiner LR, Schaffer RW. Digital Processing of Speech Signals. Englewood Cliffs, NJ: Prentice-Hall, 1978.
- Ranck JB Jr. Which elements are excited in electrical stimulation of the mammalian central nervous system: A review. *Brain Res* 1975; 98: 417-440.
- Seldon HL, Daham MC, Clark GM. Silastic with polyacrylic acid filler: Swelling properties, biocompatibility and potential use into cochlear implants. *Biomaterials* 1994; 15: 1161-1169.
- Shepherd RK, Hatsushika S, Clark GM. Electrical stimulation of the auditory nerve: The effect of electrode position on neural excitation. *Hearing Res* 1993; 66: 108-120.
- Shipp DB, Nedzelski JM. Prognostic indicators of speech recognition performance in adult cochlear implant users: A prospective analysis. *Ann Otol Rhinol Laryngol* 1995; 104 (Suppl 166): 194-196.
- Shiroma M, Honda K, Yamanaka N, Kawano J, Yukawa K, Kumakawa K, Funasaka S. Factors contributing to phoneme recognition ability of users of the 22-channel cochlear implant system. *Ann Otol Rhinol Laryngol* 1992; 101: 32-37.
- Skinner MW, Clark GM, Whitford LA, Seligman PM, Staller SJ, Shipp DB, Shallop JK, Everingham C, Menapace CM, Arndt PL, Antogenelli T, Brimacombe JA, Pijl S, Daniels P, George CR, McDermott HJ, Beiter AL. Evaluation of a new spectral peak (SPEAK) coding strategy for the Nucleus 22 channel cochlear implant system. *Am J Otol* 1994a; 15 (Suppl 2): 15-27.
- Skinner MW, Ketten DR, Vannier MW, Gates GA, Yoffie RL, Kalender WA. Determination of the position of Nucleus cochlear implant electrodes in the inner ear. *Am J Otol* 1994b; 15: 644-651.
- Summerfield AQ, Marshall DH. Preoperative predictors of outcomes from cochlear implantation in adults: Performance and quality of life. *Ann Otol Rhinol Laryngol* 1995; 104 (Suppl 166): 105-108.
- van Hoesel RJM, Clark GM. Fusion and lateralization study with two binaural cochlear implant patients. *Ann Otol Rhinol Laryngol* 1995; 104 (Suppl 166): 233-235.
- van Hoesel RJM, Clark GM. Psychophysical studies with two binaural cochlear implant subjects. *J Acoust Soc Am*, 1997; 102: 495-507.
- van Hoesel RJM, Tong YC, Hallow RD, Clark GM. Psychophysical and speech perception studies: A case report on a binaural cochlear implant subject. *J Acoust Soc Am* 1993; 94: 3178-3189.
- Wilson BS, Finley CC, Farmer JC Jr, Lawson DT, Weber BA, Wolford RD, Kenan PD, White MW, Merzenich MM, Schindler RA. Comparative studies of speech processing strategies for cochlear implants. *Laryngoscope* 1988; 98: 1069-1077.
- Wilson BS, Finley CC, Lawson DT. Speech processors for auditory prostheses. Seventh Quarterly Progress Report, NIH project N01-

- NS-3-2356. Neural Prosthesis Program, National Institutes of Health, Bethesda, MD, 1985.
- Wilson BS, Finley CC, Lawson DT, Wolford RD, Eddington DK, Rabinowitz WM. Better speech recognition with cochlear implants. *Nature* 1991; 352: 236-238.
- Wilson BS, Finley CC, Lawson DT, Zerbi M. Speech processors for auditory prostheses. Eleventh Quarterly Progress Report, NIH project N01-DC-2-2401. Neural Prosthesis Program, National Institutes of Health, Bethesda, MD, 1995a.
- Wilson BS, Finley CC, Lawson DT, Zerbi M. Temporal representations with cochlear implants. *Am J Otol*, in press.
- Wilson BS, Finley CC, Lawson DT, Zerbi M, van den Honert C. High rate coding strategies. Presented at the International Workshop on Cochlear Implants, Vienna, Austria, Oct., 1996.
- Wilson BS, Finley CC, Zerbi M, Lawson DT. Speech processors for auditory prostheses. Seventh Quarterly Progress Report, NIH project N01-DC-2-2401. Neural Prosthesis Program, National Institutes of Health, Bethesda, MD, 1994a.
- Wilson BS, Finley CC, Zerbi M, Lawson DT. Speech processors for auditory prostheses. Ninth Quarterly Progress Report, NIH project N01-DC-2-2401. Neural Prosthesis Program, National Institutes of Health, Bethesda, MD, 1994b.
- Wilson BS, Lawson DT, Zerbi M. Advances in coding strategies for cochlear implants. *Adv Otolaryngol Head Neck Surg* 1995b; 9: 105-129.
- Wilson BS, Lawson DT, Zerbi M, Finley CC, Wolford RD. Recent developments with the CIS strategies. In: Hochmair-Desoyer IJ, Hochmair ES, eds. *Advances in cochlear implants*. Vienna: Manz Interscience Series, 1994c; 103-112.
- Wilson BS, Rebscher S, Zeng F-G, Shannon RV, Loeb GE, Lawson DT, Zerbi M. Design for an inexpensive but effective cochlear implant. *Otolaryngol Head Neck Surg*, in press.
- Zeng F-G. Cochlear implants in China. *Audiology* 1995; 34: 61-75.

2

Engineering Design of Cochlear Implants

BLAKE S. WILSON

1. Introduction

The cochlear implant is the most successful neural prosthesis developed to date. Approximately 60,000 people have received cochlear implants as of this writing. This number exceeds by orders of magnitude the numbers for any other type of neural prosthesis. According to the recent National Institutes of Health (NIH) Consensus Statement on Cochlear Implants (1995), “A majority of those individuals with the latest speech processors for their implants will score above 80 percent correct on high-context sentences, even without visual cues.” This level of success is truly remarkable, given the relatively crude representations of speech and other sounds provided by present implant systems.

Although much progress has been made in the engineering design of implant systems, much remains to be done. Patients with the best results still do not hear as well as listeners with normal hearing, especially in challenging situations such as speech presented in competition with noise or other talkers. In addition, some patients still do not enjoy much benefit from implants, even with the current speech processing strategies and electrode arrays.

This chapter provides an overview of prior and current designs for cochlear implants, and presents possibilities for improvements in design.

2. Components of Implant Systems

In the great majority of cases, deafness is caused by the absence or degeneration of sensory hair cells in the inner ear. Such loss may be produced by gene defects, viral or bacterial labyrinthitis, various autoimmune diseases, Meniere’s disease, ototoxic drugs, overexposure to loud sounds, trauma, and other causes (see Niparko, Chapter 3). The function of a cochlear implant is to bypass the hair cells via direct electrical stimulation of surviving neurons in the auditory nerve. In general, at least some neurons survive

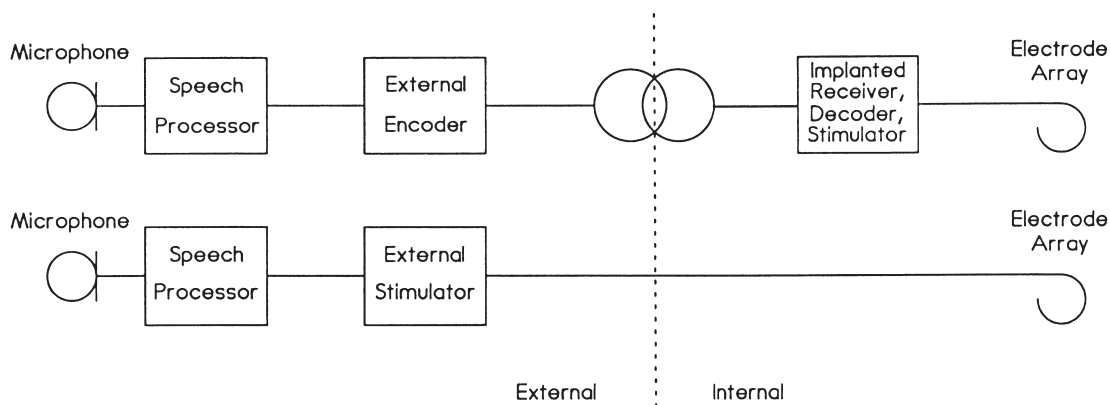

FIGURE 2.1. Components of cochlear implant systems: a system with a transcutaneous transmission link (top), and a system with a percutaneous connector (bottom). (From Wilson 1993, with permission from the Singular Publishing Group.)

even in cases of prolonged deafness and even for virulent etiologies such as meningitis (see Leake and Rebscher, Chapter 4; Hinojosa and Marion 1983).

The essential components of implant systems are shown in Figure 2.1. A microphone converts sound into an electrical signal for input to the speech processor. The processor transforms that input into a set of stimuli for an implanted electrode or array of electrodes. The stimuli are sent to the electrodes through a transcutaneous link (top) or through a percutaneous connector (bottom). A typical transcutaneous link includes encoding of the stimulus information for efficient radiofrequency transmission from an external transmitting coil to an internal (implanted) receiving coil. The signal received by the internal coil is decoded to specify stimuli for the electrodes. A cable connects the internal receiver/stimulator package to the implanted electrodes. In the case of a percutaneous connector, a cable connects pins in the connector to the electrodes.

These components are shown in a different way in Figure 2.2, which is a diagram of an implant system that uses a transcutaneous link. In this particular system a speech processor is worn on the belt or in a pocket. The processor is relatively light and small. A cable connects the output of the speech processor (a radiofrequency signal with encoded stimulus information) to a head-level unit that is worn behind the ear. A standard behind-the-ear (BTE) housing is used. A microphone is included within the BTE housing, and its output signal is amplified and then sent to the speech processor through one of the wires in the cable connecting the processor and the head-level unit. The external transmitting coil is connected to the base of the BTE housing with a separate cable. The external coil is held in place over the internal receiver/stimulator package (which includes the internal coil) with a pair of external and internal magnets. The receiver/stimulator package is implanted in a flattened or recessed portion of the skull, posterior to and slightly above the pinna (see Niparko, Chapter

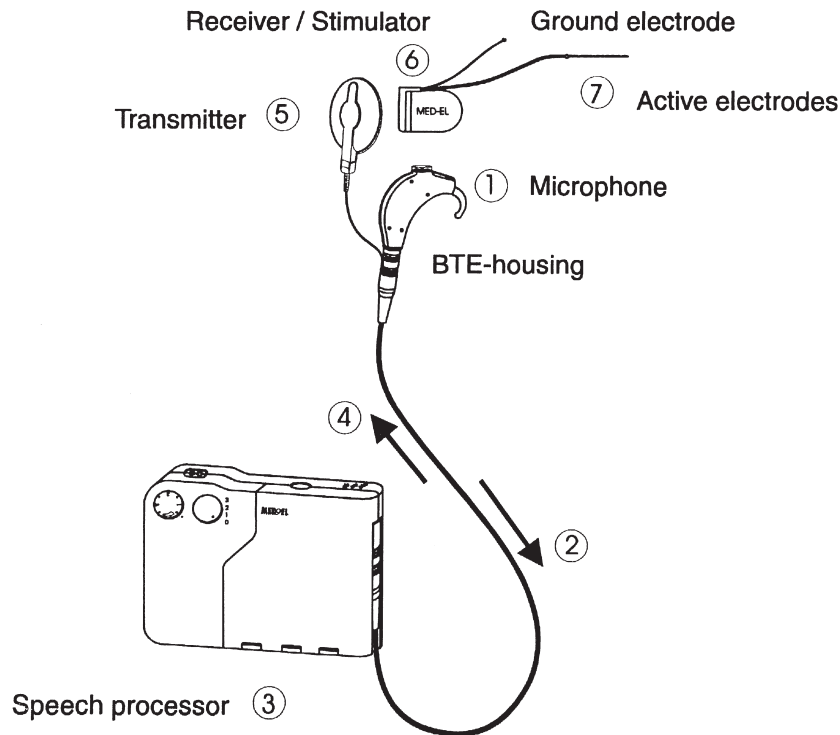

FIGURE 2.2. Schematic drawing of the Med-El Combi 40 implant system, with the major components indicated in Figure 2.1. The microphone is mounted in a behind-the-ear (BTE) headset. (Courtesy of Med-El GmbH, Innsbruck, Austria.)

3). The ground electrode is implanted at a location remote from the cochlea, usually in the temporalis muscle. For some implant systems, a metallic band around the outside of the receiver/stimulator package serves as the ground (or reference) electrode. An array of active electrodes is inserted into the scala tympani (ST) through the round window membrane or through a larger drilled opening at or near the round window.

An expanded view of the implanted cochlea is presented in Figure 4.1 in Chapter 4. This figure shows a cutaway drawing of an electrode array inserted into the first turn and part of the second turn of the ST. Different electrodes, or closely spaced pairs of “bipolar” electrodes (illustrated), ideally stimulate different subpopulations of cochlear neurons. Neurons near the base of the cochlea (first turn and lower part of the drawing) respond to high-frequency sounds in normal hearing, and neurons near the apex of the cochlea respond to low-frequency sounds. Most implant systems attempt to mimic this tonotopic encoding by stimulating basal electrodes to indicate the presence of high-frequency sounds and by stimulating apical electrodes to indicate the presence of low-frequency sounds.

Figure 4.1 in Chapter 4 indicates a partial insertion of the electrode array. This is a characteristic of all available ST implants—no array has been inserted farther than about 30 mm from the round window membrane, and typical insertion depths are much less than that, e.g., 20 to 26 mm. The figure

also shows a complete presence of hair cells (in the organ of Corti) and a pristine survival of cochlear neurons. However, the number of hair cells is either zero or close to it in the deafened cochlea. In addition, survival of neural processes peripheral to the ganglion cells (the dendrites, projecting from the ganglion cells to the organ of Corti) is rare in the deafened cochlea. Survival of the ganglion cells and central processes (the axons) ranges from sparse to substantial. The pattern of survival generally is not uniform, with reduced or sharply reduced counts of spiral ganglion cells in certain regions of the cochlea. In all, the neural “target” for a cochlear implant can be quite different from one patient to the next (see Leake and Rebscher, Chapter 4).

Figure 2.2 in the present chapter shows components of the Med-El Combi 40 implant system. Other systems share the same basic components but are different in detail. For example, systems recently introduced by Advanced Bionics Corp., Cochlear Ltd., and Med-El GmbH incorporate the speech processor within a BTE housing, eliminating the separate and much larger speech processor of prior systems and the cable connecting the processor to the BTE housing. The details of processing and of techniques for the transmission stimuli or stimulus information across the skin differ widely among implant systems. The details of the electrode design also vary widely across systems.

Some of the choices and unknowns faced by designers of implant systems are summarized in Table 2.1. Each choice may affect performance, and each

TABLE 2.1. Principal options and considerations in the design of cochlear implant systems.

Processing strategy	Transmission link
Number of channels	Percutaneous
Number of electrodes and channel-to-electrode assignments	Transcutaneous
Stimulus waveform	Maximum stimulus update rate, within and across channels
Pulsatile	Back telemetry of implant status, electrode impedances, and/or intracochlear evoked potentials
Analog	
Approach to speech analysis	
Filter-bank representation	
Feature extraction	
Electrodes	Patient
Placement	Survival of neurons in the cochlea and auditory nerve
Extracochlear	
Intracochlear	Proximity of electrodes to target neurons
Within the modiolus	
Cochlear nucleus	Function of central auditory pathways
Bilateral	Cognitive and language skills
Number and spacing of contacts	
Orientation with respect to excitable tissue	

Adapted from Wilson et al. 1995, with permission from Mosby–Year Book, Inc.

choice may interact with other choices. The variability imposed by the patient may be even more important than the particulars of implant design (Wilson et al. 1993). Even though any of several implant devices can support high levels of speech reception performance for some patients, other patients have poor outcomes with each of those same devices. Factors contributing to this variability may include differences among patients in the survival of neural elements in the implanted cochlea, proximity of the electrodes to the target neurons, integrity of the central auditory pathways, and cognitive skills.

The hardware of implant systems is described in greater detail in the remainder of this section. Further discussion of strategies for representing speech information with implants is presented in section 3, and further discussion about the patient variable is presented in section 4.

2.1 Microphone

The microphone typically is placed in the BTE housing or the speech processor enclosure. A separate “tie-tack” or “clip-on” microphone also can be placed remotely and connected to the speech processor with a thin cable. (Connection of a remote microphone typically disables the microphone in the BTE housing or speech processor enclosure.) A good microphone for an implant system has a broad frequency response but not extending to very low frequencies, so as to minimize responses to low-frequency vibrations that can be produced by head movements and walking.

A directional microphone can help in listening to speech under adverse conditions, such as attending to one speaker in competition with other speakers or in competition with background noise (e.g., as in a cafeteria). The directional pattern of sensitivity for a single microphone is determined largely by its housing and placement on the body. For example, the head can act as a baffle for high-frequency sounds from the contralateral side when the microphone is mounted at the side of the head (in a BTE unit). The length and orientation of the tube in front of the microphone can affect its frequency response and directional pattern.

The selectivity of the directional pattern can be increased substantially with the use of multiple microphones. With two microphones, for example, sounds originating between and in front of the microphones produce microphone outputs that are in phase with each other, producing a large summed output. In contrast, sounds originating from other locations produce microphone outputs that are not in phase with each other and lower summed outputs. The summed signals emphasize sounds in front of the microphones and suppress sounds from other locations.

Use of dual microphones in conjunction with adaptive filtering techniques (to enhance the above summation and cancellation effects) has been evaluated by Hamacher et al. (1997), and by Wouters and Vanden Berghe (2001). Although the processing algorithms and test procedures differed

between these two studies, results from each demonstrated highly significant gains in recognition of speech presented in competition with various types of noise and at various speech-to-noise ratios (S/Ns). (Another dual-microphone system, the Audallion Beamformer, has been made available for use with devices manufactured by Cochlear Ltd. Results from evaluation of this system for speech reception by implant patients have not been published; however, a description of the system is presented in Figueiredo et al. 2001.)

One of the future directions for cochlear implants described later in this chapter is the use of bilateral implants, for which placement of the microphones in each of the ear canals may be helpful. Sensing of sound pressure within the canal would include the spatially dependent frequency filtering provided by the pinna on both sides. (The principal component of the filtering is a deep spectral notch at high frequencies, produced by summation of sound directly entering the canal and sound reflected off the pinna/concha surfaces. The reflection path depends on the location of the sound source, and different locations produce different path lengths and different frequency positions of the notch.) Such cues might augment other cues to sound source location, that would be represented in any case with microphones at the standard location or within the canal.*

2.2 *Speech Processor*

The function of the speech processor is to convert a microphone or other input (e.g., direct inputs from a telephone, TV, CD player, or FM system) into patterns of electrical stimulation. Ideally, the outputs of the speech processor represent the information-bearing elements of speech in a way that they can be perceived by implant patients. Strategies for achieving this objective are described in section 3, below.

The processor is powered with batteries. Hearing aid batteries are used for the head-level processors (processors incorporated into the BTE housing), and larger batteries (e.g., two AA batteries) are used for the body-worn processors. Battery life typically exceeds 12 to 16 hours, allowing patients to use their devices during the waking hours without the need for recharging or replacing the batteries.

Adequate battery life for the head-level processors is made possible through the use of low-power integrated circuit technology, particularly low-power digital signal processing (DSP) chips that have become available in the past 10 years or so. Present head-level processors have all or most of

*The other principal cues are the interaural differences in amplitude and timing produced with sounds at various locations in the lateral plane. Pinna cues vary with position in the three-dimensional space, including the vertical plane and front-back positions.

the capabilities of the body-worn processors for each of the systems. Use of head-level processors is rapidly replacing use of body-worn processors, as the former are more cosmetic and more convenient than the latter.

Advances in battery, integrated circuit, and DSP chip technologies have been driven by huge commercial markets for mobile phones, portable computers, and other hand-held or portable instruments. The economic incentives to develop better batteries and power-efficient chips are enormous.

Recipients of cochlear implants have benefited from such developments, in that the developments have made possible progressively smaller and more capable speech processors and implanted receiver/stimulators. Even greater reductions in size and increases in capabilities may be available in the near future. Fully implantable systems, with the speech processor placed in the middle ear cavity, may well be available within the next several years.[†]

2.3. *Transmission Link*

A percutaneous connector or transcutaneous link is used to convey stimuli or stimulus information from the external speech processor to the implanted electrodes. A principal advantage of a percutaneous connector is signal transparency, i.e., the specification of stimuli is in no way constrained by the limitations imposed with any practical design of a transcutaneous transmission link. Also, the percutaneous connector allows high-fidelity recordings of intracochlear evoked potentials, which may prove to be useful in assessing the physiological condition of the auditory nerve on a sector-by-sector basis (Brown et al. 1990, 1998; Wilson et al. 1997a; Abbas et al. 1999) and for programming the speech processor (Brown et al. 1998, 2000; Shallop et al. 1999; Abbas et al. 2000; Mason et al. 2001; Franck 2002; Gordon et al. 2002; Seyle and Brown 2002).[‡]

An important advantage of transcutaneous links is that the skin is closed over the implanted components, which may reduce the risk of infection compared with systems using a percutaneous connector. A disadvantage is that only a limited amount of information can be transmitted across the

[†]Development of fully implantable systems is well under way or nearing completion at two of the major implant companies, at a new company in Canada, and at the University of Michigan. Two of the principal problems facing designers of fully implantable systems are (1) specification or design of batteries that do not need to be replaced any sooner than every 5 to 10 years, and (2) specification or design of microphones that can be implanted under the skin or elsewhere and yet still have an adequate signal-to-noise ratio.

[‡]Recordings of intracochlear evoked potentials may be helpful in setting currents for threshold and comfortably loud percepts for processors using relatively low rates of stimulation. However, the recordings are not good predictors of those currents for processors using high rates of stimulation (Zimmerling and Hochmair 2002). Although high-fidelity recordings of intracochlear evoked potentials are desirable, reduced-fidelity recordings may suffice for certain applications.

skin with a transcutaneous link. This usually means that the rates at which stimuli can be updated are limited and that the repertoire of stimulus waveforms is limited (e.g., restricted to biphasic pulses only for some systems).

All commercially available implant systems use a transcutaneous link. In some cases, the link is bidirectional, allowing transmission of data from the implanted components out to the external coil and speech processor or speech processor interface, as well as transmission of data from the speech processor to the implanted receiver/stimulator and electrode array. The data sent from the implanted components to the external components can include:

- information about the status of the receiver/stimulator, such as measures of critical voltages
- impedances of the implanted electrodes
- voltages at unstimulated electrodes
- neural evoked potentials, as recorded using unstimulated electrodes

Rates of transmission required for the first three measures are relatively low. However, high-fidelity recordings of intracochlear evoked potentials require high sampling rates (e.g., 50,000 samples/s), high resolution (e.g., a resolution of 12 bits or higher for the analog-to-digital converter), and rapid recovery of the recording amplifiers from the saturation produced by the presentation of stimulus pulses (van den Honert et al. 1997; Wilson 1997). The CI24M implant system, manufactured by Cochlear Ltd., has a capability to record intracochlear evoked potentials and to send the results from the internal receiver/stimulator to the external coil and speech processor interface (Brown et al. 1998). The arrangement for recording intracochlear evoked potentials is shown in Figure 2.3. A separate computer is used in conjunction with the speech processor interface and transcutaneous link to specify and transmit the stimuli to the selected stimulus electrode (or electrode pair) via the forward path of the link. Following delivery of the stimulus pulses, voltages recorded at the selected (unstimulated) electrode are encoded for transmission from the implanted receiver/stimulator back out to the external coil and speech processor interface. The computer then is used to reconstruct and plot the data received from the internal components.

The “neural response telemetry” feature of the CI24M implant does not fulfill the requirements for high-fidelity recordings noted above, and the types of stimuli that can be specified are limited. (For example, the feature has a maximum sampling rate of 20 kHz in an “interlaced” mode and a sampling resolution of approximately 9 bits.) However, the data obtained with its use may well be helpful in assessing the status of the nerve and for the fitting of speech processors (Abbas et al. 1999; Shallop et al. 1999; Brown et al. 2000; Mason et al. 2001; Franck 2002; Gordon et al. 2002; Seyle and Brown 2002).

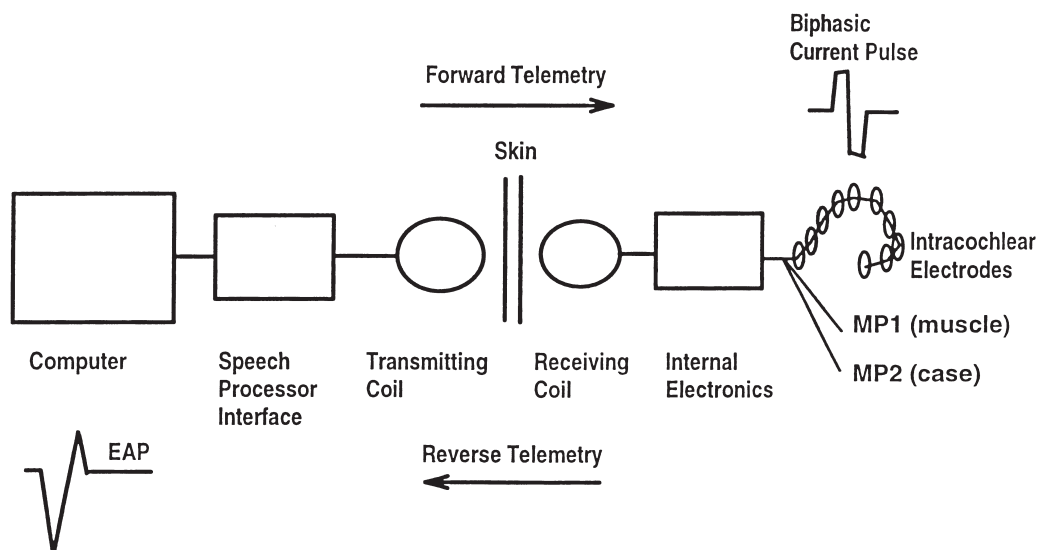

FIGURE 2.3. Schematic diagram of the system used for recording intracochlear evoked potentials in the CI24M device. EAP: Electrically evoked whole nerve Action Potential. (Courtesy of Cochlear Corporation, Englewood, CO, the U.S. subsidiary of Cochlear Ltd., Sydney, Australia.)

A capability for recording intracochlear evoked potentials also has been included in the new Clarion implant system (Frijns et al. 2002), and is called “neural response imaging” for that system. The recordings are made with a 9-bit analog-to-digital converter, and with sampling rates as high as 60 kHz. The recording amplifier also has an exceptionally fast recovery from prior saturation (less than 20 microseconds). These specifications allow better recordings than those obtained with the back-telemetry feature of the CI24M implant system. Such recordings may prove to be especially useful for assessing the physiological status of the nerve on a sector-by-sector basis.

2.4 Electrodes

The electrodes for the great majority for current implant systems are placed in the ST. The ST offers an accessible site that is relatively close to the spiral ganglion, which is not readily accessible with present surgical techniques (see Niparko, Chapter 3). The electrodes and electrode carrier (together called the electrode array) must be biocompatible and remain so over the life span of the patient. The array must also be mechanically stable and facilitate atraumatic insertion. Surgical handling of the array is determined by its stiffness and cross-sectional area. In general, flexible arrays and narrow cross-sectional areas facilitate insertion. Also, use of biocompatible lubricants, such as hyaluronic acid, can facilitate insertion (Laszig et al. 2002).

Intracochlear electrodes can be stimulated in either a monopolar or bipolar configuration. In the monopolar configuration, each intracochlear electrode is stimulated with reference to a remote electrode, usually in the

temporalis muscle or outside of the case of the implanted receiver/stimulator. In the bipolar configuration, one intracochlear electrode is stimulated with reference to another (nearby) intracochlear electrode. Different pairs of electrodes are used to stimulate different sites along the electrode array.

The spatial specificity of stimulation, for selective activation of different populations of cochlear neurons, depends on many factors, including:

- whether neural processes peripheral to the ganglion cells are present or absent
- the number and distribution of surviving ganglion cells
- the proximity of the electrodes to the target neurons
- the electrode coupling configuration

These factors can interact in ways that produce selective excitation fields for monopolar or bipolar stimulation and in ways that produce broad excitation fields for either type of stimulation. For example, highly selective fields can be produced with bipolar electrodes oriented along the length of surviving neural processes peripheral to the ganglion cells (e.g., van den Honert and Stypulkowski 1987). Highly selective fields also can be produced with close apposition of monopolar electrodes to the target neurons (e.g., Ranck 1975) or through use of “field steering” arrangements in which the field produced by a central electrode is sharpened with the simultaneous application of opposite-phase fields at neighboring electrodes (e.g., Jolly et al. 1996).

In general, broad fields become more likely with increasing distance between electrodes and target neurons for either coupling configuration. Broad fields (produced by high stimulus levels) may be required for adequate stimulation of cochleas with sparse nerve survival.

An important goal of implant design is to maximize the number of largely non-overlapping populations of neurons that can be addressed with the electrode array. This might be accomplished through the use of a bipolar coupling configuration for some situations or through positioning of electrode contacts immediately adjacent to the inner wall of the ST. Such positioning would minimize the distance between the contacts and the ganglion cells.

Several new designs of electrode arrays produce close positioning of the array next to the inner wall of the ST (e.g., Gstoettner et al. 2001; Balkany et al. 2002). Such placements can not only increase the spatial specificity of stimulation, as noted above, but also produce reductions in threshold and increases in the dynamic range of stimulation (Ranck 1975; Shepherd et al. 1993; Cohen et al. 2001).

Although placements next to the inner wall appear to produce beneficial effects in the basal turn of the cochlea, the relative efficacy of the placements may be limited in higher turns. In particular, perimodiolar placements may not be any more effective in the higher turns than standard

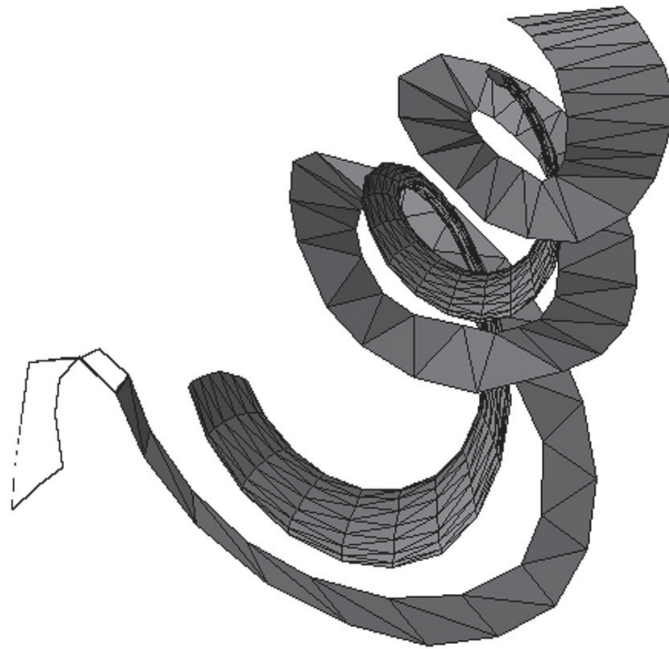

FIGURE 2.4. Depiction of the anatomic courses of the basilar membrane (outer spiral) and the spiral ganglion (inner spiral). (Diagram courtesy of Darlene Ketten and adapted from Ketten et al. 1997.)

placements (electrode array out against the lateral wall of the ST, see Shepherd et al. 1985, 1993; Gstöttner et al. 2001), due to (1) different anatomic courses of the ST and spiral ganglion, and (2) a relatively non-differentiated “clustering” of spiral ganglion cells at about the level of the second turn of the ST. Figure 2.4 illustrates these different anatomic courses (Ketten et al. 1997; also see Ariyasu et al. 1989). The course of the basilar membrane is depicted by the outer spiral and the course of Rosenthal’s canal (and, within it, the spiral ganglion) is depicted by the inner spiral. Rosenthal’s canal has $1\frac{3}{4}$ turns, whereas the ST has $2\frac{3}{4}$ turns. Closer apposition of electrodes next to the medial wall of the ST may well reduce the distance between the electrodes and target ganglion cells in the basal turn, but the distance may not be substantially reduced for higher turns. In addition, stimulation by electrodes at the second turn and higher is likely to excite the cluster of cells at the apex of the spiral ganglion (not illustrated in the figure or in Figure 4.1 in Chapter 4). Thus, different stimulus sites at and beyond the second turn may not address significantly different populations of neurons. (However, some survival of peripheral processes in the apical region of the cochlea might allow selective activation of those neural elements with deeply inserted electrodes.)

A further possible limitation of perimodiolar electrode arrays has been suggested by Frijns et al. (2001). Results from their modeling studies have

indicated that perimodiolar electrodes beyond the first turn may stimulate axons in the modiolus at lower current levels than the nearest ganglion cells. The axons are “fibers of passage,” from ganglion cells and peripheral processes that innervate higher turns of the cochlea. Exclusive stimulation of such fibers at relatively low current levels would be expected to produce unintended (and tonotopically misplaced) percepts for the patient. Stimulation of both the fibers and nearby ganglion cells at higher levels would be expected to produce complex percepts, that would correspond to excitation in multiple turns of the cochlea.

Although perimodiolar placements may not be a panacea, such placements can increase the spatial specificity and dynamic range of stimulation at least in the basal turn. The placements also can reduce thresholds and increase dynamic range for most or all electrodes in the array. These changes may in turn produce improvements in the speech reception performance of implant systems.

An alternative to perimodiolar placements is to implant electrodes directly within the auditory nerve (Simmons 1966). This relatively old concept has been resurrected by a team at the University of Utah (Maynard et al. 2001). The development includes refinement of surgical approaches and placements, and fabrication of an 8×10 array of pin electrodes suitable for a lifetime of use in humans. The dimensions of the array (1.4 mm \times 1.8 mm, with 200 μ m spacing between adjacent pins) and graded lengths of the pins (with the longest pins at 1.5 mm) approximate the cross-sectional dimensions of the auditory nerve at the level of the basal turn, where the array is to be implanted.

An intramodiolar implant offers the likely advantages of lower currents required for threshold stimulation, greater spatial selectivity of stimulation, and a greater number of stimulus sites, compared with ST implants, including ST implants with perimodiolar placements of electrodes. On the other hand, mapping of processor channel outputs onto stimulus electrodes is likely to be far more complex with intramodiolar implants. The “roping” structure of the auditory nerve presents a complex anatomy compared with the cochleotopic organization of the spiral ganglion in Rosenthal’s canal, and that complexity without doubt will complicate the fitting of speech processors used in conjunction with intramodiolar electrodes. (This problem might be addressed by placing a temporary ST implant at surgery, following placement of the intramodiolar implant. Each electrode of the ST implant would then be stimulated in sequence while recording the pattern of neural responses across all electrodes in the intramodiolar implant. Maps of the intramodiolar pin positions that correspond to the different sites of ST stimulation could be constructed from the recordings. Upon completion of the recordings, the temporary ST implant would be withdrawn and the remainder of the surgery completed. The maps of the pin positions could greatly facilitate the fitting of the speech processor at a later time.)

3. Strategies for Representing Speech Information with Implants

The performance of cochlear implants has improved dramatically since the introduction of single-channel devices in the mid-1970s. A large increment in performance was obtained with the use of multiple channels of processing and stimulation in the early 1980s (Gantz et al. 1988; Cohen et al. 1993). Steady and large improvements since that time have been produced with developments in speech processor design (e.g., Loizou 1998, 1999; Wouters et al. 1998; Clark 2000; Wilson, 2000b; David et al. 2003). Differences in the design of the multiple-electrode arrays have not produced obvious differences in performance to date, although in some studies a monopolar coupling configuration provided better results than a bipolar coupling configuration, using the Nucleus 22 electrode array (Zwolan et al. 1996; Franck et al. 2003).

Present strategies for representing speech information with cochlear implants are listed in Table 2.2. They include the continuous interleaved sampling (CIS; see Wilson et al. 1991), spectral peak (SPEAK; see Skinner et al. 1994; Seligman and McDermott 1995; Patrick et al. 1997), advanced combination encoder (ACE; see Arndt et al. 1999; Vandali et al. 2000; Kiefer et al. 2001), “ n -of- m ” (corresponding to selection of n among m channels for stimulation in each “sweep” across channels; see Wilson et al. 1988; McDermott et al. 1992; Lawson et al. 1996; Ziese et al. 2000), and simultaneous analog stimulation (SAS; see Battmer et al. 1997; Osberger and Fisher 2000) strategies. As described in the references above, each of these strategies can support relatively high levels of speech reception for a sub-

TABLE 2.2. Processing strategies used with implant systems in present use.

System	CIS	n -of- m	ACE	SPEAK	SAS
Combi 40, 40+	•	•			
Laura	•				
CI22				•	
CI24M	•		•	•	
Clarion	•				•

Note: The Combi 40 and Combi 40+ systems are manufactured by Med-El GmbH of Innsbruck, Austria; the Laura system was recently manufactured by Philips Hearing Instruments and before that by Antwerp Bionic Systems, in Antwerp, Belgium (manufacture of this system has been discontinued); the CI22 was manufactured by Cochlear Ltd. of Sydney, Australia, up until 1997; the CI24M system is manufactured by Cochlear Ltd. now; and several versions of the Clarion system have been manufactured by Advanced Bionics Corp. of Sylmar, CA. As described in Wilson, 2000b, the ACE strategy can be regarded as a close variation of the n -of- m strategy. Systems are listed in the leftmost column and the strategies used with each are indicated in the remaining columns. See text for full names of the strategies. Note that the strategies indicate broad categories and that the details of implementation for a given strategy can vary (sometimes widely) across systems.

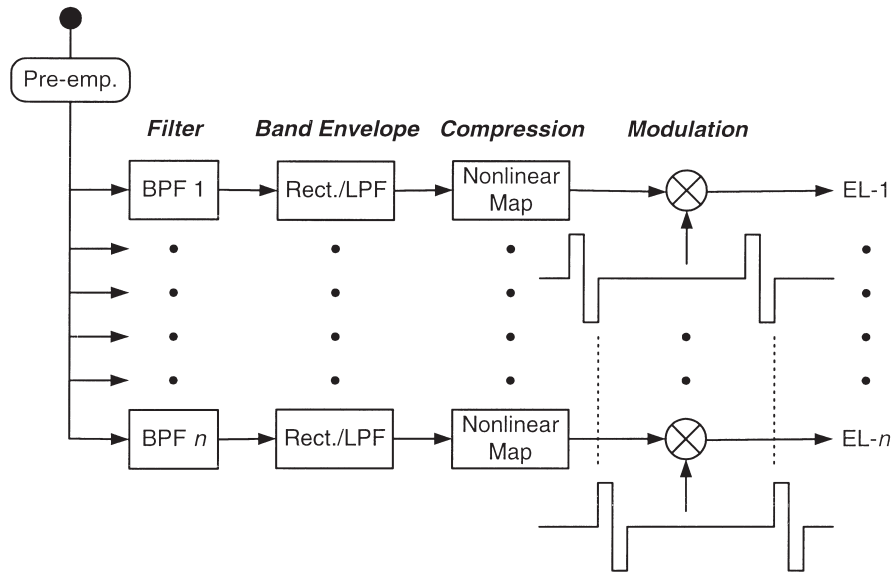

FIGURE 2.5. Block diagram of a continuous interleaved sampling (CIS) processor. Pre-emp.: preemphasis; BPF: band pass filter; Rect.: rectifier; LPF: low-pass filter; EL: electrode. (Adapted from Wilson et al. 1991, with permission from Macmillan Publishers Ltd.)

stantial subpopulation of users. However, a wide range of outcomes persists with any of the strategies, with some users obtaining only modest if any benefit from their implants.

3.1 CIS Strategy

As indicated in Table 2.2, the CIS strategy is available as a processing option for each of the three major implant systems in current use. A block diagram of the strategy is presented in Figure 2.5. Inputs from a microphone and optional automatic gain control (AGC) are directed to a preemphasis filter, which attenuates frequency components below 1.2 kHz at 6 dB/octave. This preemphasis helps relatively weak consonants (with a predominant frequency content above 1.2 kHz) compete with vowels, which are intense compared with most consonants and have strong components below 1.2 kHz.

The output of the preemphasis filter is directed to a bank of bandpass channels. Each channel includes stages of bandpass filtering, envelope detection, and compression. Envelope detection typically is accomplished with a rectifier, followed by a low-pass filter (a Hilbert transform also has been used for envelope detection, see, e.g., Helms et al. 2001). A logarithmic transformation is used to map the relatively wide dynamic range of derived envelope signals onto the narrow dynamic range of electrically evoked hearing. The channel outputs are used to modulate trains of biphasic pulses. This transformation produces a normal or nearly normal growth

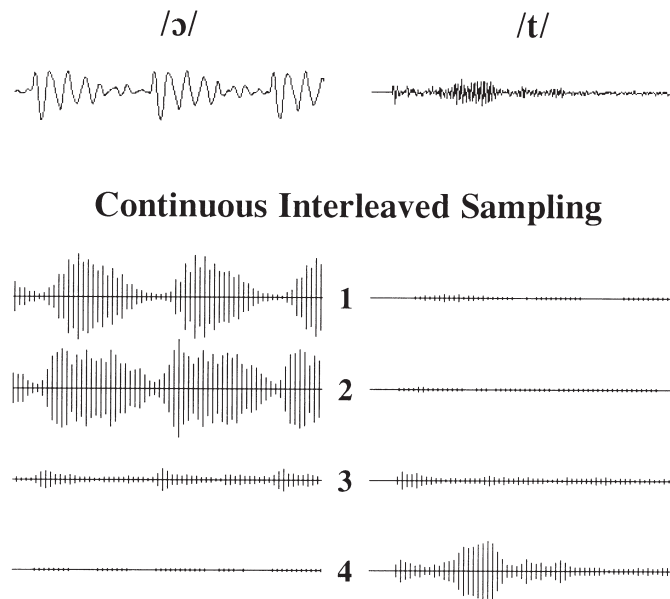

FIGURE 2.6. Stimuli produced by a simplified implementation of a continuous interleaved sampling (CIS) processor. The top panels show preemphasized (6 dB/octave attenuation below 1.2 kHz) speech inputs. An input corresponding to a voiced speech sound (“aw”) is shown in the left panel and an input corresponding to an unvoiced speech sound (“t”) is shown in the right panel. The bottom panels show stimulus pulses produced by a CIS processor for these inputs. The numbers indicate the electrodes to which the stimuli are delivered. The lowest number corresponds to the apical-most electrode and the highest number to the basal-most electrode. The pulse amplitudes in the figure reflect the amplitudes of the envelope signals for each channel. In actual implementations, the range of pulse amplitudes is compressed using a logarithmic or power-law transformation of the envelope signal for each channel. The duration of each of the trances is 25.4 ms. (Adapted from Wilson et al. 1991, with permission from Macmillan Publishers Ltd.)

of loudness with increases in sound level (Eddington et al. 1978; Zeng and Shannon 1992; Dorman et al. 1993). The modulated pulses for each channel are applied through a percutaneous or transcutaneous link to a corresponding electrode in the cochlea. Stimuli derived from channels with low center frequencies for the bandpass filter are directed to apical electrodes in the implant, and stimuli derived from channels with high center frequencies are directed to basal electrodes in the implant.

Patterns of stimulation for a simplified implementation of a four-channel CIS processor are illustrated in Figure 2.6. Speech inputs are shown in the top panels, and stimulus pulses are shown for each of four electrodes (and channels) in the bottom panels. The four electrodes are arranged in an apex-to-base order, with electrode 4 being the most basal. The amplitudes of the pulses for each of the electrodes are derived from the envelope signals in the corresponding bandpass channels. The envelope signal in the bandpass channel with the lowest center frequency controls the amplitudes of pulses

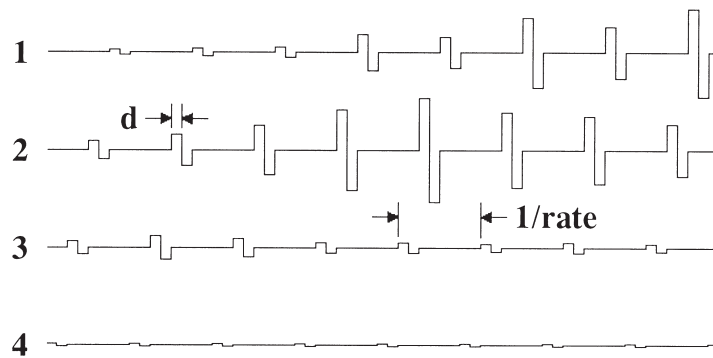

FIGURE 2.7. Expanded display of continuous interleaved sampling (CIS) stimuli. Pulse duration per phase (d) and the period between pulses on each electrode ($1/\text{rate}$) are indicated. The sequence of stimulated electrodes is 4-3-2-1 (a base-to-apex order). The duration of each trace is 3.3 ms. (Adapted from Wilson et al. 1991, with permission from Macmillan Publishers Ltd.)

delivered to the apical-most electrode, and the envelope signal in the band-pass channel with the highest center frequency controls the amplitude of pulses delivered to the basal-most electrode. This arrangement mimics the tonotopic organization of the cochlea in normal hearing, with high-frequency sounds exciting neurons at basal locations and low-frequency sounds exciting neurons at apical locations.

Continuous interleaved sampling processors use relatively high rates of stimulation to represent rapid temporal variations within channels. The pulse rate must be higher than twice the cutoff frequency of the low-pass filters (in the envelope detectors) to avoid aliasing effects (Rabiner and Shafer 1987; Wilson 1997). Results from recent recordings of auditory nerve responses to sinusoidally amplitude modulated pulse trains indicate that the rate should be even higher—four to five times the cutoff frequency—to avoid other distortions in the neural representations of the modulation waveforms (Wilson et al. 1994; Wilson 1997, 2000c). A typical CIS processor might use a pulse rate of 1000 pulses/s/electrode or higher, in conjunction with a 200-Hz cutoff for the low-pass filters.

An expanded display of stimuli during a short segment of the vowel input is presented in Figure 2.7. This display shows the interlacing and order of stimulus pulses across electrodes. In this particular implementation of a CIS processor, stimulus pulses are delivered in a non-overlapping sequence from the basal-most electrode (electrode 4) to the apical-most electrode (electrode 1). The rate of pulses on each electrode may be varied through manipulation in the duration of the pulses and the time between sequential pulses. Any ordering of electrodes may be used in the stimulation sequence, such as an apex-to-base order or a staggered order (i.e., an order designed to produce on average the maximum spatial separation between sequentially stimulated electrodes).

Unlike some prior processing strategies for implants, no specific features of speech are extracted or represented with CIS processors. Instead, envelope variations in each of multiple bands are presented to the electrodes through modulated trains of interleaved pulses. The rate of stimulation for each channel and electrode does not vary between voiced and unvoiced sounds (see illustration of this by comparing the left and right panels of Fig. 2.6). This “waveform” or “filter-bank” representation does not make any assumptions about how speech is produced or perceived.

A key feature of the CIS, *n-of-m*, ACE, and SPEAK strategies is the interlacing of stimulus pulses across electrodes. This eliminates a principal component of interaction among electrodes that otherwise would be produced through vector summation of the electric fields from different (simultaneously stimulated) electrodes (e.g., Favre and Pelizzone 1993). Such interaction, if allowed to stand, would be expected to reduce the salience of channel-related cues.

An additional aspect of the CIS, *n-of-m*, and ACE strategies is relatively high cutoff frequencies for the low-pass filters in the envelope detectors, along with rates of stimulation that are sufficiently high to represent the highest frequencies without aliasing or other distortions. The cutoff frequencies generally are in the range of 200 to 400 Hz. This range encompasses the fundamental frequency of voiced speech sounds (see periodicity of envelope variations in the lower left panels of Fig. 2.6) and rapid transitions in speech such as those produced by stop consonants. The range also does not exceed the perceptual space of typical patients. In particular, most patients perceive changes in frequency or rate of stimulation as changes in pitch up to about 300 Hz or 300 pulses/s, respectively (e.g., Shannon 1983; Tong et al. 1983; Townshend et al. 1987; Zeng 2002). Further increases in frequency or rate do not produce further increases in pitch for a majority of patients, for loudness-balanced stimuli. Some subjects have higher pitch saturation limits, as high as about 1000 Hz, but these subjects are the exception rather than the rule (Hochmair-Desoyer et al. 1983; Townshend et al. 1987; Wilson et al. 1997b). Thus, representation of frequencies much beyond 300 Hz probably would not convey any additional information that could be perceived or utilized by typical patients.

3.2. *n-of-m and ACE Strategies*

The CIS, *n-of-m*, and ACE strategies share (1) nonsimultaneous stimulation and (2) high cutoff frequencies for the envelope detectors. The principal difference between the CIS and the other strategies is that the channel outputs are “scanned” in the latter strategies to select the n channels with the highest envelope signals prior to each frame of stimulation across electrodes. Stimulus pulses are delivered only to the subset of m electrodes that correspond to the n selected channels. This “peak picking” scheme is designed to reduce the density of stimulation while still representing the

most important aspects of the acoustic environment. It also allows a lower overall stimulus rate, that might be accommodated with a limited-bandwidth transcutaneous transmission system. The deletion of low-amplitude channels for each frame of stimulation may reduce the overall level of masking across electrode and stimulus regions in the implanted cochlea. To the extent that the omitted channels do not contain significant information, such “unmasking” may improve the perception of the input signal by the patient.

The *n-of-m* and ACE strategies are quite similar in design. The *n-of-m* approach was first described in 1988 (Wilson et al. 1988) and has been refined in several lines of subsequent development (e.g., McDermott et al. 1992; Lawson et al. 1996; McDermott and Vandali 1997). Current implementations include those listed in Table 2.2, along with laboratory implementations. Comparisons between *n-of-m* (or ACE) and CIS have indicated roughly equivalent performances for the two (e.g., Lawson et al. 1996; Ziese et al. 2000) or somewhat better performance for the *n-of-m* approach (e.g., Kiefer et al. 2001). The results have varied from subject to subject and also among different implementations of the strategies, using the Combi 40+, CI24M, or laboratory hardware and software.

Work to evaluate and refine *n-of-m* processors is still in progress. The choices of *n* and *m* probably are important, as the *m* electrodes most likely should be perceptually distinct for the best performance (limiting the number for practical electrode arrays), and *n* should be high enough to include all essential information but lower than *m* to provide any reduction in the density or overall rate of stimulation. In addition, there may be better ways to choose the *n* channels and electrodes for each frame of stimulation. Flanagan (1972), for example, describes various alternative procedures for identifying the channels for analogous “peak picking” vocoders (see also Loizou 1998). Those procedures were more effective for vocoders than a simple selection of maxima, and they might be more effective for implants as well.

3.3 SPEAK Strategy

The SPEAK strategy uses an adaptive *n-of-m* approach, in which *n* may vary from one stimulus frame to the next. The input is filtered into as many as 20 bands. Envelope signals are derived as in the CIS, *n-of-m*, and ACE strategies above, with an envelope cutoff frequency of 200 Hz. The number of bandpass channels selected in each scan (the adaptive *n*) depends on the number of envelope signals exceeding a preset “noise threshold” and on details of the input such as the distribution of energy across frequencies. In many cases, six channels are selected. However, the number can range from one to a maximum that can be set as high as 10. Cycles of stimulation, which include the selected channels and associated electrodes, are presented at rates between 180 and 300/s. The amount of time required to complete each

cycle depends on the number of electrodes and channels included in the cycle (n) and the pulse amplitudes and durations for each of the electrodes. In general, inclusion of relatively few electrodes in a cycle allows relatively high rates, whereas inclusion of many electrodes reduces the rate.

A diagram illustrating the operation of the SPEAK strategy is presented in Figure 2.8. The speech input is directed to a bank of bandpass filters and envelope detectors, whose outputs are scanned for each cycle of stimulation. In this diagram, six channels are selected in each of two scans, and the corresponding electrodes are stimulated sequentially in a base-to-apex order. The diagram does not illustrate the compressive mapping of envelope signals onto pulse amplitudes.

The SPEAK strategy was designed for use with the N22 implant system. The transcutaneous link in that system is relatively slow, e.g., the maximum cycle rate for six channels of stimulation is about 400/s under ideal conditions (Crosby et al. 1985; Shannon et al. 1990). This limitation constrained the design of the strategy such that the average rate was set at about 250 cycles/s, and the range of rates is between 180 and 300/s, as noted above.

The rates used in the SPEAK strategy, in combination with the 200-Hz cutoff for the envelope detectors, are substantially lower than the minimum required to prevent aliasing and other distortions. For the average rate of 250/s, the representation of frequencies in the modulation waveforms above 125 Hz is subject to aliasing effects, and the representation of frequencies in the range of one-fourth to one-half the pulse rate probably is distorted to a lesser extent (Busby et al. 1993; McKay et al. 1994; Wilson 1997).

Results from recent comparisons of the SPEAK and ACE strategies generally have indicated superiority of the latter (e.g., Arndt et al. 1999; Kiefer et al. 2001; Pasanisi et al. 2002). The performance of the SPEAK strategy may be affected by (1) relatively low rates of stimulation, (2) aliasing and other distortions arising from the use of low rates in conjunction with a high cutoff frequency for the envelope detectors, or (3) some combination of these factors. At present, the ACE strategy is regarded by many clinicians as the “default” or “first-choice” strategy for the CI24M implant system.

3.4 SAS Strategy

The SAS strategy was derived from a compressed analog (CA) strategy (Eddington 1980; Merzenich et al. 1984), originally used in somewhat different implementations with the now-discontinued University of California at San Francisco (UCSF)/Storz and Ineraid implant systems. In contrast to the other strategies described above, the CA and SAS strategies use “analog” or continuous waveforms for stimuli, instead of biphasic pulses. A block diagram of the CA strategy is presented in Figure 2.9. A microphone or other input is compressed with a fast-acting AGC. The AGC output is filtered into contiguous bands (usually four in the UCSF/Storz and Ineraid implementations), that span the range of speech frequencies. The signal

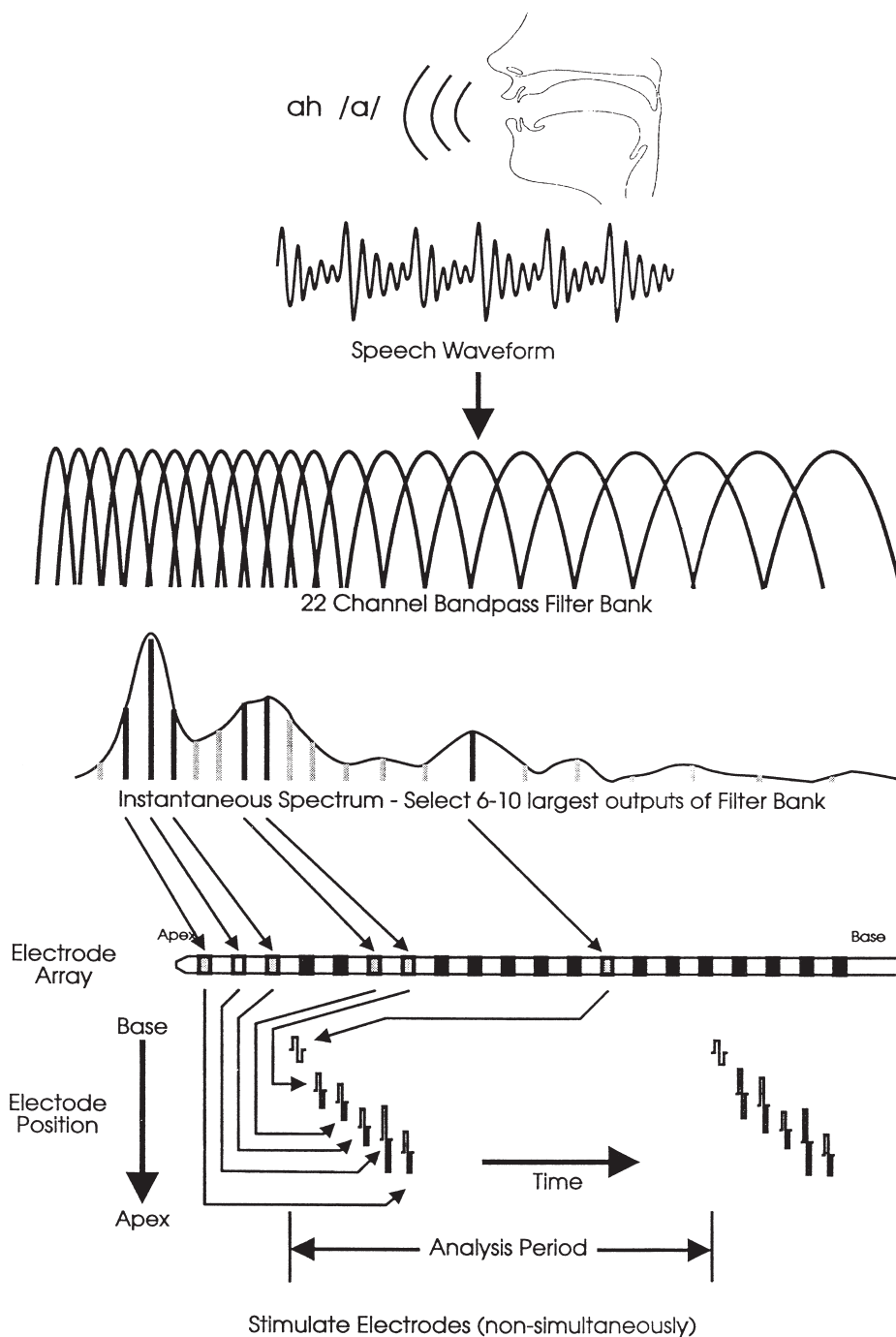

FIGURE 2.8. Key steps in the spectral peak (SPEAK) processing strategy. Speech inputs are directed to a bank of up to 20 bandpass filters and envelope detectors. The envelope signals are scanned just prior to each cycle of stimulation across electrodes. Between 1 and 10 of the highest-amplitude signals are selected in each scan, depending on characteristics of the input (i.e., overall level and spectral composition). Electrodes associated with the selected envelope signals (and bandpass channels) are stimulated in a base-to-apex order. (From Patrick et al. 1997, with permission from the Singular Publishing Group, Inc.)

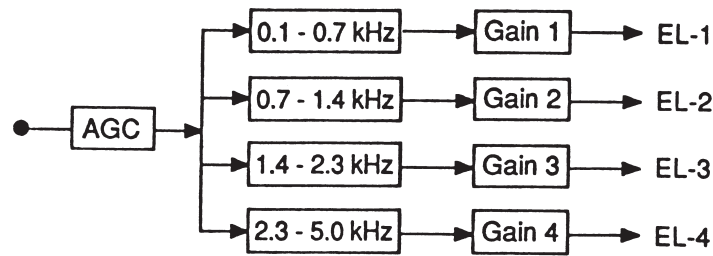

FIGURE 2.9. Block diagram of a compressed analog (CA) processor. The CA strategy uses a broadband automatic gain control (AGC), followed by a bank of bandpass filters. The outputs of the filters are adjusted with independent gain controls. Compression is achieved through rapid action of the AGC, and high-frequency emphasis and limited mapping to individual electrodes is accomplished through adjustments of the channel gains. (Adapted from Wilson et al. 1991, with permission from Macmillan Publishers Ltd.)

from each bandpass filter is amplified and then directed to a corresponding electrode in the implant. The gains of the amplifiers for the different bandpass filters can be adjusted to produce stimuli that do not exceed the upper end of the dynamic range of percepts for each electrode and that provide a high-frequency emphasis (e.g., percepts for high-frequency channel 4 can be made as loud as percepts for low-frequency channel 1, even though high-frequency sounds in speech generally are much less intense than low-frequency sounds).

The compression provided by the AGC can reduce the dynamic range of the input to approximate the dynamic range of electrically evoked hearing. The dynamic range of stimulation also can be restricted with a clipping circuit before or after the amplifiers, for some or all of the bandpass channels (Merzenich et al. 1984; Merzenich 1985). Of course, such “front-end” compression introduces spectral components that are not present in the input. The severity of this distortion depends on the time constants of the AGC (attack and release) and the compression ratio of the AGC (e.g., White 1986). Thus, a balance must be met between sufficient compression for mapping the wide dynamic range of the input onto the narrow dynamic range of electrically evoked hearing, and introduction of spurious frequency components, principally in the high-frequency channels.

Stimuli produced by a simplified implementation of a CA processor are shown in Figure 2.10. This figure has the same format as Figure 2.6 (which shows stimuli for a CIS processor). The CA stimuli represent a large portion of the information in the unprocessed speech input. Spectral and temporal patterns of speech are represented in the relative amplitudes of the stimuli across electrodes and in the temporal variations of the stimuli for each of the electrodes.

Although a large amount of information is presented with CA stimuli, much of it may not be available to implant patients. As mentioned before,

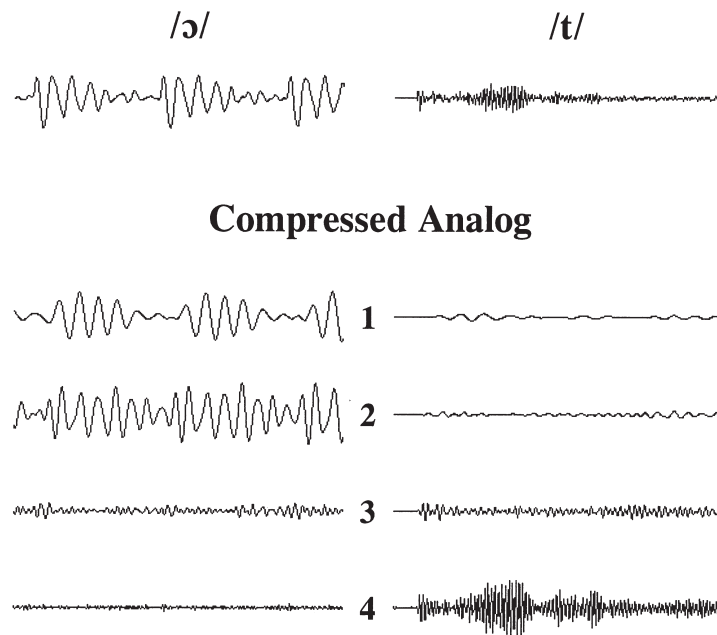

FIGURE 2.10. Stimuli produced by a simplified implementation of a compressed analog (CA) processor. The organization and speech inputs for this figure are the same as those in Figure 2.6. This simplified implementation does not include effects of a front-end AGC or adjustment of gains for the different channels. (Adapted from Wilson et al. 1991, with permission from Macmillan Publishers Ltd.)

within-channel changes in frequency above about 300 Hz are not perceived as changes in pitch by many patients. In addition, the simultaneous stimulation of multiple electrodes can produce large and uncontrolled interactions through vector summation (at sites of neural excitation) of the electric fields from each of the electrodes (White et al. 1984; Favre and Pelizzone 1993). The resulting degradation of independence among electrodes would be expected to reduce the salience of channel-related cues. In particular, the neural response to stimuli presented at one electrode may be significantly distorted or even counteracted by coincident stimuli presented at other electrodes. The pattern of interaction also may vary according to the instantaneous phase relationships among the stimuli for each of the electrodes. Phase is not controlled in CA processors, and this may degrade further the representation of channel-by-channel amplitudes.

Certain likely limitations of the CA approach have been addressed in the design of the SAS strategy. The SAS strategy includes a logarithmic mapping function at the output of each bandpass channel, to provide “back-end” rather than “front-end” compression. As with the CIS and other pulsatile strategies above, such back-end compression allows the mapping of stimuli on a channel-by-channel basis and also eliminates the spurious, cross-channel spectral components introduced by front-end compression. As with the other strategies, the SAS strategy can include a front-end AGC,

but with long time constants and a low compression ratio, to minimize any distortions.

The SAS strategy also is used in conjunction with electrode arrays designed to produce spatially selective patterns of stimulation, either through a particular orientation of electrodes for each channel of stimulation (the “offset radial” orientation, see Loeb et al. 1983, or the “enhanced bipolar” configuration, see Battmer et al. 1999) or through the use of techniques to place electrodes close to the target neurons in the spiral ganglion (e.g., Lenarz et al. 2000; Zwolan et al. 2001; Balkany et al. 2002; Frijns et al. 2002). To the extent that the design goals of these electrode arrays are fulfilled, interactions among electrodes may be relatively low compared with other designs (e.g., an array of monopolar electrodes not deliberately positioned immediately adjacent to the inner wall of the ST).

Present implementations of the SAS strategy include those in the Clarion CI and CII implant systems. The CI implant uses a “precurved” electrode array and has eight independent current sources. The CII implant uses an electrode positioning device (inserted at surgery behind and after a flexible electrode array with 16 contacts) and has 16 current sources. Up to eight channels of bipolar stimulation (between closely spaced pairs of electrodes in the array) can be supported with the CI implant, and up to 16 can be supported with the CII implant. (The number of channels is limited to seven when the enhanced bipolar configuration is used in conjunction with the CI implant.) The electrode array with the positioning device is called the “HiFocus” electrode.

Prior comparisons between the CA and CIS strategies showed a marked superiority of the latter (e.g., Wilson et al. 1991; Boëx et al. 1996; Pelizzone et al. 1999). Recent comparisons of the SAS and CIS strategies, as implemented in the Clarion hardware and software, have produced varied results across studies, but generally have demonstrated high levels of performance for some subjects using SAS. The studies conducted to date have included those listed in Table 2.3. The studies of Battmer et al. (1999), Osberger and Fisher (2000), and Stollwerck et al. (2001) used the CI implant and associated electrode array, and the study of Frijns et al. (2002) used the CII implant with the HiFocus electrode. The study of Zwolan et al. (2001) used both systems, in separate groups of subjects. In these latter studies (Frijns et al. and Zwolan et al.), new capabilities of the speech processor and transcutaneous link in the CII implant were not utilized as such use had not yet been approved by the U.S. Food and Drug Administration at the time of the studies. Thus, for example, CIS implementations used the relatively low pulse rates of the CI implant and a maximum of eight channels of processing and stimulation. (The maximum number of channels for SAS also was set at eight.)

An additional strategy, paired pulsatile stimulation (PPS), was included in some of the studies. It is a variation of CIS in which pairs of distant electrodes are stimulated simultaneously, with stimulation of the pairs in a

TABLE 2.3. Comparisons among continuous interleaved sampling (CIS), paired pulsatile stimulation (PPS), and simultaneous analog stimulation (SAS) strategies, as implemented in either the Clarion CI or CII implant systems.

Study	Device	Subjects	Percent preferring		
			CIS	PPS	SAS
Battmer et al. 1999	CI	22 ^a	50	N/A	50
Osberger and Fisher 2000	CI	58	72	N/A	28
Zwolan et al. 2001	CI	56	50	11	39
	CII	56	15	33	52
Stollwerck et al. 2001 ^b	CI	55	75	N/A	25
Frijns et al. 2002	CII	10	90	10	0

Note: Subject preferences are indicated. For studies that included multiple test intervals, results for the final interval are given. The PPS strategy was not included in some of the comparison studies, as indicated by N/A in the PPS column.

^aTwo of the subjects could not use SAS, due to inadequate loudness. The data in the “percent preferring” columns reflect findings for the 20 subjects who could use both the SAS and CIS strategies.

^bWithin-subject comparisons demonstrated that the subjects performed better with their preferred strategy.

nonsimultaneous sequence. This approach doubles the rate of stimulation across all electrodes, while possibly minimizing interactions between the simultaneously stimulated electrodes by choosing electrodes in each pair that are far apart from each other. [The PPS strategy also has been called the “multiple pulsatile sampler” (MPS) strategy.]

In each of the studies the subjects have been asked to indicate their preference between the SAS and CIS strategies, or among the SAS, CIS, and PPS strategies. The results are listed in Table 2.3. They vary widely across studies. In the study of Battmer et al. (1999), approximately half of the subjects preferred SAS to CIS and also achieved scores with SAS that were comparable to the scores achieved by the other subjects with CIS. In the study of Osberger and Fisher (2000), less than 30% of the subjects preferred SAS, but some of those subjects had exceptionally high scores (on average, scores for the SAS and CIS groups were not different at the final, 6-month test interval). The subjects preferring SAS had short durations of deafness compared to the CIS group. In the study of Zwolan et al. (2001), SAS was compared with both CIS and PPS. At the final (again, 6-month) test interval, approximately 50% of the 56 subjects using the CI implant and pre-curved electrode array preferred CIS, and about 40% and 10% of those subjects preferred SAS and PPS, respectively. For the additional 56 subjects using the CII implant and HiFocus electrode array, approximately 15% preferred CIS, and about 52% and 33% preferred SAS and PPS, respectively. Zwolan et al. attributed this reversal in preference, for the two types of electrode array, to a closer positioning of electrodes next to the inner wall of the ST with the new electrode array. Presumably such positioning, if

present, would reduce interactions among electrodes and thereby perhaps allow simultaneous stimulation strategies to become more useful. In another group of 55 subjects using the CI implant system, Stollwerck et al. (2001) found that 75% of the subjects preferred CIS over SAS. Among the 10 subjects studied by Frijns et al. (2002), nine preferred CIS, one PPS, and none SAS. These subjects used the CII implant and HiFocus electrode array (but with the positioner inserted only along the basal turn, see Frijns et al. 2002).

Speech reception data also have been collected for at least the preferred strategy for each subject in each of the studies. Controlled comparisons between or among strategies, balancing experience and other variables across strategies, also have been made in the study of Stollwerck et al. (2001). In broad terms, results from all studies, except the study of Frijns et al. (2002) (in which none of subjects stated a preference for SAS), indicated levels of performance for the group preferring SAS that were comparable to those of the group preferring CIS. In addition, some of the subjects in each of the groups had especially high scores. Results from the study of Stollwerck et al. also showed that subjects performed better with their preferred strategy.

The SAS strategy may convey more temporal information than the CIS strategy, especially in the apical (low-frequency) channels and especially for patients who can perceive changes in frequency as changes in pitch over relatively wide ranges. If so, that advantage may outweigh the likely disadvantage of higher electrode interactions, which would be expected even with a spatially selective electrode array (Loizou et al. 2003).

3.5 “HiRes” Strategy

The CIS implementations in the above comparisons used eight channels and a carrier rate of about 800 pulses/s/electrode. This may have limited the performance of the strategy in that more channels and/or higher rates may have been helpful. Indeed, an increase in the number of perceptually separable channels beyond eight would be expected to improve speech reception, especially for speech presented in competition with noise (Friesen et al. 2001; Dorman et al. 2002). In addition, results from studies using other implant systems indicate significant benefits of higher rates of stimulation for at least some patients (e.g., Brill et al. 1997; Kiefer et al. 2000; Loizou et al. 2000; Wilson et al. 2000).

A variation of CIS, called the HiRes strategy, has been implemented for use with the Clarion CII implant system (Frijns et al. 2002). It utilizes the full capabilities of the device. The HiRes strategy can present pulses at rates up to 90,000/s across the addressed electrodes, and the strategy can support up to 16 channels of processing and stimulation. A typical fitting would include 16 channels and a carrier rate of 2800 to 5600 pulses/s/electrode. The fidelity of the temporal representation provided with HiRes might

match or exceed that provided with SAS. At the same time, electrode interactions are minimized in HiRes through the use of nonsimultaneous stimuli. This might increase the number of perceptually separable channels well beyond the maximum available with SAS.

Initial studies to evaluate HiRes have included a clinical trial sponsored by the Advanced Bionics Corp. In that study, HiRes was compared with the preferred strategy among the prior CIS, PPS, or SAS strategies for each of 80 subjects, implanted with the HiFocus electrode and positioner across 19 centers in North America. Phase I of the study included use by each subject of their preferred prior strategy for 3 months. Phase II included use of HiRes for the subsequent 3 months. Speech reception data were collected at the conclusions of the two phases, and a preference questionnaire was given at the end of phase II. The speech reception tests included recognition of monosyllabic words and recognition of key words in the Central Institute for the Deaf (CID) and Hearing in Noise Test (HINT) sentences. The speech items were presented in quiet for all tests, and also at the S/N of +10 dB for the HINT sentence test. As of September 2002, 51 of the 80 subjects had completed phase II (Osberger et al. 2002). The mean scores for the 51 were significantly higher with HiRes compared to the control strategies for each of the administered tests. The greatest gains were observed for speech reception in noise, with an increase from 47% to 61% correct in the mean scores for the HINT sentences at the S/N +10 dB. Subjects with relatively low scores using the control strategy showed a larger gain overall than subjects with relatively high scores. (Ceiling effects may have limited the sensitivity of the test for some of the latter subjects.) Ninety percent of the subjects indicated a preference for HiRes at the conclusion of phase II.**

The initial studies also have included comparisons of CIS processors using 833 pulses/s/electrode versus processors using 1400 pulses/s/electrode (Frijns et al. 2003). Each of the nine subjects had used a processor with the lower rate and eight channels (and electrodes) for a period of 3 to 11 months. They then were fitted in randomized orders with 8-, 12-, or 16-channel processors using the higher rate. Each of the processors was used for 1 month prior to testing, and then the next processor was fitted. Tests with all processors included recognition of monosyllabic words in quiet and in competition with noise at the S/Ns of +10, +5, 0, and -5 dB. The results demonstrated significant differences in scores between the rates and across the numbers of channels. Some patients achieved their best scores with the higher rate and eight channels, whereas others achieved their best scores with the higher rate and 12 or 16 channels. These best scores showed a substantial and significant advantage of the higher rate for speech reception in noise, consistent with the results of the prior studies cited above.

** Note that the additional experience gained with HiRes, following the initial experience with the control strategies, may have favored HiRes in these comparisons.

HiRes has become the default strategy for the CII system.[‡] More information about its performance should be available in the near future.

3.6 Summary

All present processing strategies for cochlear implants use a “filter-bank” or “waveform” approach. Explicit extraction and representation of specific features of speech was abandoned in the early 1990s. All but one of the present strategies use biphasic pulses as stimuli, presented in a nonsimultaneous sequence across electrodes. The SAS strategy presents “analog” or continuous waveforms as stimuli simultaneously to all (utilized) electrodes. This strategy produces good results for some subjects that are comparable to results produced with CIS using the Clarion CI implant system.

4. Design Considerations

Many factors can affect the performance of implant systems. Some of those factors are described above, e.g., choices among processing strategies and various electrode designs. Additional important factors include the patient variable, fitting procedures, and the hardware and software implementations of processing strategies.

4.1 Patient Variable

One of the most striking findings from research on implants is that the range of performance across patients is large for any of a variety of implant systems. Some patients score at or near 100% correct on standard audiological tests of sentence and word recognition in quiet, whereas other patients obtain zero scores using an identical speech processor and electrode array. Although average scores across patients have increased substantially with the introductions of new processing strategies, a wide range of performance still remains.

Data indicating the importance of the patient variable are presented in Figure 2.11, which shows a scatter plot of scores for recognition of Northwestern University Auditory Test 6 (NU-6) monosyllabic words, from within-subject comparisons of CA and CIS processors (Wilson et al. 1993). These scores were obtained with careful fittings of the two processing strategies and with high-quality implementations of both (see below). Note that relatively low scores for one strategy are associated with relatively low scores for the other strategy and vice versa. The data points in the figure

[‡]The electrode positioner device is no longer used with the CII system, due to a possible association between such use and meningitis (e.g., Arnold et al. 2002).

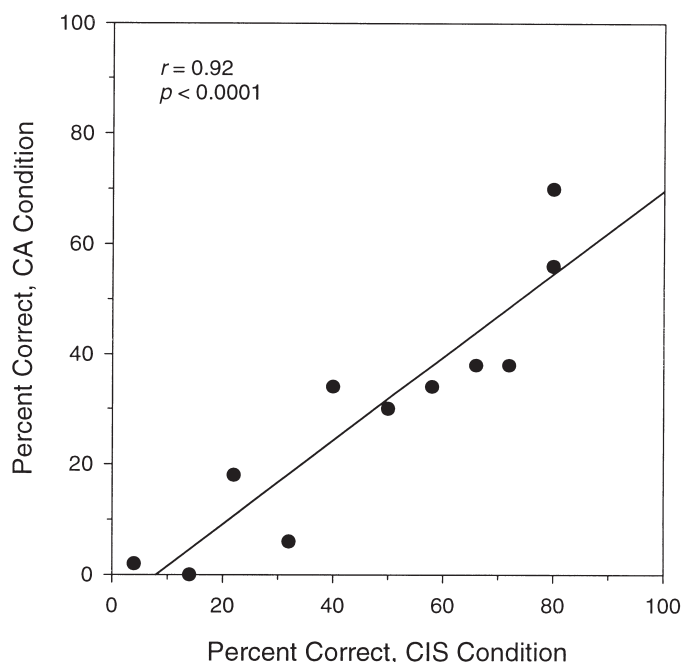

FIGURE 2.11. Scatter plot of percent-correct scores for the recognition of Northwestern University Auditory Test 6 (NU-6) monosyllabic words. Each point represents the scores obtained with the compressed analog (CA) and continuous interleaved sampling (CIS) processing strategies for one subject. Different lists of words were used for the tests with the different strategies. The Pearson correlation coefficient, level of significance, and regression line are also shown in the figure. (Data from Wilson et al. 1993.)

are highly correlated ($r = 0.92$), indicating that 85% of the variance in the results is explained by the subject (or patient) variable ($r^2 = 0.85$). Correlations for other tests not limited by ceiling effects also are quite high for these subjects and processors, in a range between 0.87 and 0.92 (Wilson et al. 1993).

Identification of the factors that underlie the effects of the patient variable may lead to the development of reliable prognostic tests for prospective patients (e.g., Rubinstein et al. 1999a). The factors may be related to the condition of the auditory nerve (see Leake and Rebscher, Chapter 4), the integrity of the central auditory system (see Hartmann and Kral, Chapter 6), the cognitive abilities of a patient (see Pisoni and Cleary, Chapter 9), or some combination of these possibilities. Knowledge of the factors should help in the design of better implant systems that take these factors into account and minimize or eliminate their deleterious effects for patients who otherwise would have relatively poor outcomes.

4.2 Fitting Procedures

Large improvements in the performance of a cochlear implant system can be obtained for individual patients through informed choices of parameter

values. In studies with CIS processors, for example, quite large gains have been produced through choices of pulse rate, pulse duration, electrode update order, the range of frequencies spanned by the bandpass filters, and other parameter values (e.g., Wilson et al. 1995; Loizou et al. 2000). Although predetermined values for some parameters may be appropriate for virtually all patients, the values of other parameters should be varied over certain ranges to optimize performance for individuals.

4.3 Strategy Implementations

The performance of a processing strategy also can be affected by the quality of its implementation. Seemingly subtle changes in hardware and the programming of that hardware can produce large changes in performance. Such effects have been demonstrated in comparisons between versions of commercial implant systems that were designed to implement the same processing strategy. Dowell et al. (1991) compared two versions of the Nucleus device (the WSP III and MSP versions), each of which was designed to implement the F0/F1/F2 processing strategy, and found significant increases in speech reception scores with the newer implementation (the MSP version). Similarly, Battmer et al. (1997) found significant improvements in speech test scores when the Clarion version 1.2 implementation of a CIS strategy was substituted for the prior version 1.1 implementation of that strategy.

Examples of ways in which an implementation can go awry include use of microphones with poor frequency response or high levels of noise, use of amplifier and AGC circuits with low dynamic ranges or high levels of noise, use of digital filters with a reduced number of elements compared with conventional and well-functioning digital filters (a reduced number of elements has been used in devices with small memories or slow DSP chips), use of current sources that are especially noisy, use of current sources that saturate or begin to saturate in the dynamic ranges of the electrodes for some or all patients (current sources saturate when the commanded current requires a voltage at the electrodes that approaches or exceeds the “compliance” or voltage limit of the device), and an excessive amount of digital or switching noise that appears at the electrodes. Any one of these factors can degrade or destroy the performance of an otherwise good strategy.

5. Future Directions

A number of efforts are under way to improve the design and performance of present implant systems. They include:

- Use of bilateral implants to (1) increase the number of perceptually independent stimulus sites and thereby improve speech reception in noise or (2) restore at least to some extent sound localization abilities and the signal-to-noise advantages that accompany such abilities (e.g., Lawson et al. 2000, 2001a; Gantz et al. 2002; Müller et al. 2002; Tyler et al. 2002a; van Hoesel et al. 2002).
- Combined electric and acoustic stimulation of the auditory system for patients with some remaining (low-frequency) hearing, with the two modes of stimulation used for opposite ears (e.g., Armstrong et al. 1997; Lawson et al. 2001b; Tyler et al. 2002b) or with both acoustic and electric stimuli delivered to the same ear (von Ilberg 1999; Lawson et al. 2001b; Kiefer et al. 2002; Wilson et al. 2003b).
- Drug delivery through the implant (e.g., Clark 2001), to preserve neurons or even promote the growth of neurites (toward the electrode array) from existing neurons or regeneration of neurons and associated structures (also see Qun et al. 1999, for descriptions of, and studies with, various neurotrophic factors).
- Development of new processing strategies that emphasize the representation of important transients in speech (Geurts and Wouters 1999; Vandali 2001).
- Use of high carrier rates, or high-rate “conditioner” pulses, in conjunction with CIS and other strategies, to (1) increase the correspondence between modulation waveforms and temporal patterns of neural responses, (2) increase the dynamic range of responses, and (3) reinstate at least to some degree a normal pattern of stochastic or “spontaneous” activity in auditory neurons (Wilson et al. 1997a; Rubinstein et al. 1999b; Wilson 2000c; Litvak et al. 2001).
- Development of new processing strategies designed to replicate closely the signal transformations in normal cochlea, including (1) the nonlinear filtering that occurs at the basilar membrane and outer hair cell complex, and (2) the stages of instantaneous and noninstantaneous compression that occur at the inner hair cells and at the synapses between the cells and adjacent fibers of the auditory nerve (Wilson et al., 2003a).
- Applications of new and emerging knowledge about factors that are highly correlated with outcomes for implants, in the design of approaches or training procedures to help patients presently at the low end of the performance spectrum (e.g., Fu 2002).

Each of these efforts, except for drug delivery through the implant, is described in detail in a recent article by Wilson et al. (2003a). Drug delivery and additional possibilities for the further development of implant systems are presented in two recent reviews by Clark (2000, 2001). Selected developments also are described in somewhat older but still relevant articles by Klinke and Hartmann (1997), Lenarz (1997), and Wilson (1997, 2000c).

6. Summary

Cochlear implant systems include a microphone, speech processor, transcutaneous or percutaneous link, and an electrode array. In general, design choices for any one of these components may affect or interact with choices for other components. The design problem should be viewed at the system level.

In addition to choices in the design of the hardware (and associated software), factors presented by the patient can exert large effects on performance. Indeed, the patient variable probably is the most important of all variables in implant design.

Current processing strategies for implants all use a “waveform” or “filter-bank” approach. In addition, all but one of the strategies use biphasic pulses as stimuli, presented in a sequential and non-overlapping sequence across electrodes.

The design of cochlear implants is changing rapidly, with the advent of combined electric and acoustic stimulation of the auditory system, perimodiolar electrode arrays, and high-rate and conditioner-pulses stimuli. New processing strategies, designed to provide a closer mimicking of signal transformations in the normal auditory periphery, are being developed. Additional developments that are under way include those for intramodiolar implants and fully implantable devices. Implants of the near future may be quite unlike today’s implants, with better performance overall and, it is hoped, with a much smaller range of outcomes across patients.

Acknowledgments. Preparation of this chapter was supported by National Institutes of Health (NIH) projects N01-DC-8-2105 and N01-DC-2-1002. Portions of text in the chapter were updated or adapted from prior publications (Wilson, 2000a,b).

Many people have contributed to the ideas and findings presented here. I am most grateful to have had the grand opportunity to work with such talented and dedicated colleagues.

References

- Abbas PJ, Brown CJ, Shallop JK, Firszt JB, et al. (1999) Summary of results using the nucleus CI24M implant to record the electrically evoked compound action potential. *Ear Hear* 20:45–59.
- Abbas PJ, Brown CJ, Hughes ML, Gantz BJ, et al. (2000) Electrically evoked compound action potentials recorded from subjects who use the nucleus CI24M device. *Ann Otol Rhinol Laryngol* 185(suppl):6–9.
- Ariyasu L, Galey FR, Hilsinger R Jr, Byl FM (1989) Computer-generated three-dimensional reconstruction of the cochlea. *Otolaryngol Head Neck Surg* 100:87–91.

- Armstrong M, Pegg P, James C, Blamey P (1997) Speech perception in noise with implant and hearing aid. *Am J Otol* 18(suppl):S140–S141.
- Arndt P, Staller S, Arcaroli J, Hines A, Ebinger K (1999) Within-subjects comparison of advanced coding strategies in the Nucleus 24 cochlear implant. Technical Report, Cochlear Corporation, Englewood, CO.
- Arnold W, Bredberg G, Gstöttner W, Helms J, et al. (2002) Meningitis following cochlear implantation: pathomechanisms, clinical symptoms, conservative and surgical treatments. *ORL J Otorhinolaryngol Relat Spec* 64:382–389.
- Balkany TJ, Eshraghi AA, Yang N (2002) Modiolar proximity of three perimodiolar cochlear implant electrodes. *Acta Otolaryngol* 122:363–369.
- Battmer RD, Feldmeier I, Kohlenberg A, Lenarz T (1997) Performance of the new Clarion speech processor 1.2 in quiet and in noise. *Am J Otol* 18:S144–S146.
- Battmer RD, Zilberman Y, Haake P, Lenarz T (1999) Simultaneous analog stimulation (SAS)–continuous interleaved sampler (CIS) pilot comparison study in Europe. *Ann Otol Rhinol Laryngol* 177(suppl):69–73.
- Boëx C, Pelizzone M, Montandon P (1996) Speech recognition with a CIS strategy for the Ineraid multichannel cochlear implant. *Am J Otol* 17:61–68.
- Brill S, Gstöttner W, Helms J, von Ilberg C, et al. (1997) Optimization of channel number and stimulation rate for the fast continuous interleaved sampling strategy in the COMBI 40+. *Am J Otol* 18:S104–S106.
- Brown CJ, Abbas PJ, Gantz B (1990) Electrically evoked whole-nerve action potentials: data from human cochlear implant users. *J Acoust Soc Am* 88:1385–1391.
- Brown CJ, Abbas PJ, Gantz BJ (1998) Preliminary experience with neural response telemetry in the nucleus CI24M cochlear implant. *Am J Otol* 19:320–327.
- Brown CJ, Hughes ML, Luk B, Abbas PJ, Wolaver A, Gervais J (2000) The relationship between EAP and EABR thresholds and levels used to program the nucleus 24 speech processor: data from adults. *Ear Hear* 21:151–163.
- Busby PA, Tong YC, Clark GM (1993) The perception of temporal modulations by cochlear implant patients. *J Acoust Soc Am* 94:124–131.
- Clark GM (2000) The cochlear implant: a search for answers. *Cochlear Implants Int* 1:1–15.
- Clark GM (2001) Cochlear implants: climbing new mountains. *Cochlear Implants Int* 2:75–97.
- Cohen LT, Saunders E, Clark GM (2001) Psychophysics of a prototype perimodiolar cochlear implant electrode array. *Hear Res* 155:63–81.
- Cohen NL, Waltzman SB, Fisher SG (1993) A prospective, randomized study of cochlear implants. *N Engl J Med* 328:233–237.
- Crosby PA, Daly CN, Money DK, Patrick JF, Seligman PM, Kuzma JA (1985) Cochlear implant system for an auditory prosthesis. U.S. patent 4532930.
- David EE, Ostroff JM, Shipp D, Nedzelski JM, et al. (2003) Speech coding strategies and revised cochlear implant candidacy: an analysis of post-implant performance. *Otol Neurotol* 24:228–233.
- Dorman MF, Smith L, Parkin JL (1993) Loudness balance between acoustic and electric stimulation by a patient with a multichannel cochlear implant. *Ear Hear* 14:290–292.
- Dorman MF, Loizou PC, Spahr AJ, Maloff E (2002) A comparison of the speech understanding provided by acoustic models of fixed-channel and channel-picking signal processors for cochlear implants. *J Speech Lang Hear Res* 45:783–788.

- Dowell RC, Dawson PW, Dettman SJ, Shepherd RK, et al. (1991) Multichannel cochlear implantation in children: a summary of current work at the University of Melbourne. *Am J Otol* 12(suppl 1):137–143.
- Eddington DK (1980) Speech discrimination in deaf subjects with cochlear implants. *J Acoust Soc Am* 68:885–891.
- Eddington DK, Dobbelle WH, Brackman DE, Mladejovsky MG, Parkin JL (1978) Auditory prosthesis research with multiple channel intracochlear stimulation in man. *Ann Otol Rhinol Laryngol* 87(suppl 53):1–39.
- Favre E, Pelizzone M (1993) Channel interactions in patients using the Ineraid multichannel cochlear implant. *Hear Res* 66:150–156.
- Figueiredo JC, Abel SM, Papsin BC (2001) The effect of the audallion BEAMformer noise reduction preprocessor on sound localization for cochlear implant users. *Ear Hear* 22:539–547.
- Flanagan JL (1972) *Speech Analysis, Synthesis and Perception*, 2nd ed. Berlin, Heidelberg and New York: Springer-Verlag, pp. 330–331.
- Franck KH (2002) A model of a nucleus 24 cochlear implant fitting protocol based on the electrically evoked whole nerve action potential. *Ear Hear* 23(suppl):67S–71S.
- Franck KH, Xu L, Pfungst BE (2003) Effects of stimulus level on speech perception with cochlear prostheses. *J Assoc Res Otolaryngol* 4:49–59.
- Friesen LM, Shannon RV, Baskent D, Wang X (2001) Speech recognition in noise as a function of the number of spectral channels: comparison of acoustic hearing and cochlear implants. *J Acoust Soc Am* 110:1150–1163.
- Frijns JH, Briaire JJ, Grote JJ (2001) The importance of human cochlear anatomy for the results with modiolus-hugging multichannel cochlear implants. *Otol Neurotol* 22:340–349.
- Frijns JH, Briaire JJ, de Laat JA, Grote JJ (2002) Initial evaluation of the Clarion CII cochlear implant: speech perception and neural response imaging. *Ear Hear* 23:184–197.
- Frijns JH, Klop WM, Bonnet RM, Briaire JJ (2003) Optimizing the number of electrodes with high-rate stimulation of the Clarion CII cochlear implant. *Acta Otolaryngol* 123:138–142.
- Fu Q-J (2002) Temporal processing and speech recognition in cochlear implant users. *Neuroreport* 13:1–5.
- Gantz BJ, Tyler RS, Knutson JF, Woodworth G, et al. (1988) Evaluation of five different cochlear implant designs: audiologic assessment and predictors of performance. *Laryngoscope* 98:1100–1106.
- Gantz BJ, Tyler RS, Rubinstein JT, Wolaver A, et al. (2002) Binaural cochlear implants placed during the same operation. *Otol Neurotol* 23:169–180.
- Geurts L, Wouters J (1999) Enhancing the speech envelope of continuous interleaved sampling processors for cochlear implants. *J Acoust Soc Am* 105:2476–2484.
- Gordon KA, Ebinger KA, Gilden JE, Shapiro WH (2002) Neural response telemetry in 12- to 24-month-old children. *Ann Otol Rhinol Laryngol* 189(suppl):42–48.
- Gstoettner WK, Adunka O, Franz P, Hamzavi J Jr, et al. (2001) Perimodiolar electrodes in cochlear implant surgery. *Acta Otolaryngol* 121:216–219.
- Hamacher V, Doering WH, Mauer G, Fleischman H, Hennecke J (1997) Evaluation of noise reduction systems for cochlear implant users in different acoustic environments. *Am J Otol* 18:S46–S49.

- Helms J, Müller J, Schön F, Winkler F, et al. (2001) Comparison of the TEMPO+ ear-level speech processor and the CIS pro+ body-worn processor in adult MED-EL cochlear implant users. *ORL J Otorhinolaryngol Relat Spec* 63:31–40.
- Hinojosa R, Marion M (1983) Histopathology of profound sensorineural deafness. *Ann N Y Acad Sci* 405:459–484.
- Hochmair-Desoyer IJ, Hochmair ES, Burian K, Stiglbanner HK (1983) Percepts from the Vienna cochlear prosthesis. *Ann N Y Acad Sci* 405:295–306.
- Jolly CN, Spelman FA, Clopton BM (1996) Quadrupolar stimulation for cochlear prostheses: modeling and experimental data. *IEEE Trans Biomed Eng* 43:857–865.
- Ketten DR, Skinner MW, Gates GA, Nadol JB Jr, Neely JG (1997) In vivo measures of intracochlear electrode position and Greenwood frequency approximations. Abstracts for the 1997 Conference on Implantable Auditory Prostheses, Pacific Grove, CA, p. 33. (The book of abstracts is available from the House Ear Institute, Los Angeles, CA.)
- Kiefer J, von Ilberg C, Hubner-Egener J, Rupprecht V, Knecht R (2000) Optimized speech understanding with the continuous interleaved sampling speech coding strategy in cochlear implants: effect of variations in stimulation rate and number of channels. *Ann Otol Rhinol Laryngol* 109:1009–1020.
- Kiefer J, Hohl S, Sturzebecher E, Pfennigdorff T, Gstoettner W (2001) Comparison of speech recognition with different speech coding strategies (SPEAK, CIS, and ACE) and their relationship to telemetric measures of compound action potentials in the Nucleus CI 24M cochlear implant system. *Audiology* 40:32–42.
- Kiefer J, Tillein J, von Ilberg C, Pfennigdorff T, et al. (2002) Fundamental aspects and first results of the clinical application of combined electric and acoustic stimulation of the auditory system. In: Kubo T, Takahashi Y, Iwaki T, eds. *Cochlear Implants—An Update*. The Hague: Kugler Publications, pp. 569–576.
- Klinke R, Hartmann R (1997) Basic neurophysiology of cochlear implants. *Am J Otol* 18:S7–S10.
- Laszig R, Ridder GJ, Fradis M (2002) Intracochlear insertion of electrodes using hyaluronic acid in cochlear implant surgery. *J Laryngol Otol* 116:371–372.
- Lawson DT, Wilson BS, Zerbi M, Finley CC (1996) Speech processors for auditory prostheses: 22 electrode percutaneous study—results for the first five subjects. Third Quarterly Progress Report, NIH project N01-DC-5-2103, Neural Prosthesis Program, National Institutes of Health, Bethesda, MD. (This report is available online at <http://scientificprograms.nidcd.nih.gov/npp/index.html>.)
- Lawson DT, Brill S, Wolford RD, Wilson BS, Schatzer R (2000) Speech processors for auditory prostheses: binaural cochlear implant findings—summary of initial studies with eleven subjects. Ninth Quarterly Progress Report, NIH project N01-DC-8-2105, Neural Prosthesis Program, National Institutes of Health, Bethesda, MD. (This report is available online at <http://scientificprograms.nidcd.nih.gov/npp/index.html>.)
- Lawson DT, Wolford RD, Brill SM, Schatzer R, Wilson BS (2001a) Speech processors for auditory prostheses: further studies regarding benefits of bilateral cochlear implants. Twelfth Quarterly Progress Report, NIH project N01-DC-8-2105, Neural Prosthesis Program, National Institutes of Health, Bethesda, MD. (This report is available online at <http://scientificprograms.nidcd.nih.gov/npp/index.html>.)
- Lawson DT, Wolford RD, Brill SM, Wilson BS, Schatzer R (2001b) Speech processors for auditory prostheses: cooperative electric and acoustic stimulation of the

- auditory periphery—comparison of ipsilateral and contralateral implementations. Thirteenth Quarterly Progress Report, NIH project N01-DC-8-2105, Neural Prosthesis Program, National Institutes of Health, Bethesda, MD. (This report is available online at <http://scientificprograms.nidcd.nih.gov/npp/index.html>.)
- Lenarz T (1997) Cochlear implants—What can be achieved? *Am J Otol* 18:S2–S3.
- Lenarz T, Kuzma J, Weber BP, Reuter G, et al. (2000) New Clarion electrode with positioner: insertion studies. *Ann Otol Rhinol Laryngol* 185(suppl):16–18.
- Litvak L, Delgutte B, Eddington D (2001) Auditory nerve fiber responses to electric stimulation: modulated and unmodulated pulse trains. *J Acoust Soc Am* 110:368–379.
- Loeb GE, Byers CL, Rebscher SJ, Casey DE, et al. (1983) Design and fabrication of an experimental cochlear prosthesis. *Med Biol Eng Comput* 21:241–254.
- Loizou PC (1998) Mimicking the human ear: an overview of signal processing strategies for cochlear prostheses. *IEEE Sig Proc Mag* 15:101–130.
- Loizou PC (1999) Signal-processing techniques for cochlear implants. *IEEE Eng Med Biol Mag* 18:34–46.
- Loizou PC, Poroy O, Dorman M (2000) The effect of parametric variations of cochlear implant processors on speech understanding. *J Acoust Soc Am* 108:790–802.
- Loizou PC, Stickney G, Mishra L, Assmann P (2003) Comparison of speech processing strategies used in the Clarion implant processor. *Ear Hear* 24:12–19.
- Mason SM, Cope Y, Garnham J, O'Donoghue GM, Gibbin KP (2001) Intra-operative recordings of electrically evoked auditory nerve action potentials in young children by use of neural response telemetry with the nucleus CI24M cochlear implant. *Br J Audiol* 35:225–235.
- Maynard E, Norman R, Shelton C, Najaragan S (2001) The feasibility of an intraneural auditory prosthesis stimulating array. First Quarterly Progress Report, NIH project N01-DC-1-2108, Neural Prosthesis Program, National Institutes of Health, Bethesda, MD. (This report is available online at <http://scientificprograms.nidcd.nih.gov/npp/index.html>.)
- McDermott HJ, Vandali AE (1997) Spectral maxima sound processor. U.S. patent 5597380.
- McDermott HJ, McKay CM, Vandali AE (1992) A new portable sound processor for the University of Melbourne/Nucleus Limited multielectrode cochlear implant. *J Acoust Soc Am* 91:3367–3391.
- McKay CM, McDermott HJ, Clark GM (1994) Pitch percepts associated with amplitude-modulated current pulse trains in cochlear implantees. *J Acoust Soc Am* 96:2664–2673.
- Merzenich MM (1985) UCSF cochlear implant device. In: Schindler RA, Merzenich MM, eds. *Cochlear Implants*. New York: Raven Press, pp. 121–130.
- Merzenich MM, Rebscher SJ, Loeb GE, Byers CL, Schindler RA (1984) The UCSF cochlear implant project. *Adv Audiol* 2:119–144.
- Müller, Schön F, Helms J (2002) Speech understanding in quiet and noise in bilateral users of the MED-EL COMBI 40/40+ cochlear implant system. *Ear Hear* 23:198–206.
- NIH Consensus Statement (1995) Cochlear implants in adults and children. Office of Medical Applications of Research, National Institutes of Health, Bethesda, MD. *JAMA* 274:1955–1961.

- Osberger MJ, Fisher L (2000) New directions in speech processing: patient performance with simultaneous analog stimulation. *Am Otol Rhinol Laryngol* 185(suppl):70–73.
- Osberger MJ, Koch DB, Zimmerman-Phillips S, Segel P, Kruger T, Kessler DK (2002) Clarion CII Bionic Ear: HiRes clinical results. Abstracts for the Seventh International Cochlear Implant Conference, Manchester, U.K., Abstract 1.13.1.
- Pasanisi E, Bacciu A, Vincenti V, Guida M, et al. (2002) Comparison of speech perception benefits with SPEAK and ACE coding strategies in pediatric Nucleus CI24M cochlear implant recipients. *Int J Pediatr Otorhinolaryngol* 64:159–163.
- Patrick JF, Seligman PM, Clark GM (1997) Engineering. In: Clark GM, Cowan RSC, Dowell RC, eds. *Cochlear Implantation for Infants and Children: Advances*. San Diego, CA: Singular Publishing Group, pp. 125–145.
- Pelizzone M, Cosendai G, Tinembart J (1999) Within-patient longitudinal speech reception measures with continuous interleaved sampling processors for Ineraid implanted subjects. *Ear Hear* 20:228–237.
- Qun LX, Pirvola, U, Saarma M, Ylikoski J (1999) Neurotrophic factors in the auditory periphery. *Ann N Y Acad Sci* 884:292–304.
- Rabiner LR, Shafer RW (1978) *Digital Processing of Speech Signals*. Englewood Cliffs, NJ: Prentice-Hall.
- Ranck JB Jr (1975) Which elements are excited in electrical stimulation of the mammalian central nervous system: a review. *Brain Res* 98:417–440.
- Rubinstein JT, Parkinson WS, Tyler RS, Gantz BJ (1999a) Residual speech recognition and cochlear implant performance: effects of implantation criteria. *Am J Otol* 20:445–452.
- Rubinstein JT, Wilson BS, Finley CC, Abbas PJ (1999b) Pseudospontaneous activity: stochastic independence of auditory nerve fibers with electrical stimulation. *Hear Res* 127:108–118.
- Seligman P, McDermott H (1995) Architecture of the Spectra 22 speech processor. *Ann Otol Rhinol Laryngol* 166(suppl):139–141.
- Seyle K, Brown CJ (2002) Speech perception using maps based on neural response telemetry measures. *Ear Hear* 23(suppl):72S–79S.
- Shallop JK, Facer GW, Peterson A (1999) Neural response telemetry with the nucleus CI24M cochlear implant. *Laryngoscope* 109:1755–1759.
- Shannon RV (1983) Multichannel electrical stimulation of the auditory nerve in man. I. Basic psychophysics. *Hear Res* 11:157–189.
- Shannon RV, Adams DD, Ferrel RL, Palumbo RL, Grandgenett M (1990) A computer interface for psychophysical and speech research with the Nucleus cochlear implant. *J Acoust Soc Am* 87:905–907.
- Shepherd RK, Clark GM, Pyman BC, Webb RL (1985) Banded intracochlear electrode array: evaluation of insertion trauma in human temporal bones. *Acta Otolaryngol* 399(suppl):19–31.
- Shepherd RK, Hatsushika S, Clark GM (1993) Electrical stimulation of the auditory nerve: the effect of electrode position on neural excitation. *Hear Res* 66:108–120.
- Simmons FB (1966) Electrical stimulation of the auditory nerve in man. *Arch Otolaryngol* 84:2–54.
- Skinner MW, Clark GM, Whitford LA, Seligman PM, et al. (1994) Evaluation of a new spectral peak (SPEAK) coding strategy for the Nucleus 22 channel cochlear implant system. *Am J Otol* 15(suppl 2):15–27.

- Stollwerck LE, Goodrum-Clarke K, Lynch C, Armstrong-Bednall G, et al. (2001) Speech processing strategy preferences among 55 European CLARION cochlear implant users. *Scand Audiol Suppl* 2001:36–38.
- Tong YC, Blamey PJ, Dowell RC, Clark GM (1983) Psychophysical studies evaluating the feasibility of a speech processing strategy for a multiple-channel cochlear implant. *J Acoust Soc Am* 74:73–80.
- Townshend B, Cotter N, Van Compernelle D, White RL (1987) Pitch perception by cochlear implant subjects. *J Acoust Soc Am* 82:106–115.
- Tyler RS, Gantz BJ, Rubinstein JT, Wilson BS, et al. (2002a) Three-month results with bilateral cochlear implants. *Ear Hear* 23(suppl):80S–89S.
- Tyler RS, Parkinson AJ, Wilson BS, Witt S, Preece JP, Noble W (2002b) Patients utilizing a hearing aid and a cochlear implant: speech perception and localization. *Ear Hear* 23:98–105.
- Vandali AE (2001) Emphasis of short-duration acoustic speech cues for cochlear implant users. *J Acoust Soc Am* 109:2049–2061.
- Vandali AE, Whitford LA, Plant KL, Clark GM (2000) Speech perception as a function of electrical stimulation rate: using the Nucleus 24 cochlear implant system. *Ear Hear* 21:608–624.
- van den Honert C, Stypulkowski PH (1987) Single fiber mapping of spatial excitation patterns in the electrically stimulated auditory nerve. *Hear Res* 29:195–205.
- van den Honert C, Finley CC, Wilson BS (1997) Speech processors for auditory prostheses: development of the evoked potentials laboratory. Ninth Quarterly Progress Report, NIH project N01-DC-5-2103, Neural Prosthesis Program, National Institutes of Health, Bethesda, MD. (This report is available online at <http://scientificprograms.nidcd.nih.gov/npp/index.html>.)
- van Hoesel R, Ramsden R, O’Driscoll M (2002) Sound-direction identification, interaural time delay discrimination, and speech intelligibility advantages in noise for a bilateral cochlear implant user. *Ear Hear* 23:137–149.
- von Ilberg C, Kiefer J, Tillein J, Pfennigdorff T, et al. (1999) Electric-acoustic stimulation of the auditory system. *ORL J Otorhinolaryngol Relat Spec* 61:334–340.
- White MW (1986) Compression systems for hearing aids and cochlear prostheses. *J Rehabil Res Dev* 23:25–39.
- White MW, Merzenich MM, Gardi JN (1984) Multichannel cochlear implants: channel interactions and processor design. *Arch Otolaryngol* 110:493–501.
- Wilson BS (1993) Signal processing. In: Tyler RS, ed. *Cochlear Implants: Audiological Foundations*. San Diego, CA; Singular Publishing Group, pp. 35–85.
- Wilson BS (1997) The future of cochlear implants. *Br J Audiol* 31:205–225.
- Wilson BS (2000a) Cochlear implant technology. In: Niparko JK, Kirk KI, Mellon NK, Robbins AM, Tucci DL, Wilson BS, eds. *Cochlear Implants: Principles & Practices*. Philadelphia: Lippincott Williams & Wilkins, pp. 109–119.
- Wilson BS (2000b) Strategies for representing speech information with cochlear implants. In: Niparko JK, Kirk KI, Mellon NK, Robbins AM, Tucci DL, Wilson BS, eds. *Cochlear Implants: Principles & Practices*. Philadelphia: Lippincott Williams & Wilkins, pp. 129–170.
- Wilson BS (2000c) New directions in implant design. In: Waltzman SB, Cohen N, eds. *Cochlear Implants*. New York: Thieme Medical and Scientific Publishers, pp. 43–56.

- Wilson BS, Finley CC, Farmer JC Jr, Lawson DT, et al. (1988) Comparative studies of speech processing strategies for cochlear implants. *Laryngoscope* 98:1069–1077.
- Wilson BS, Finley CC, Lawson DT, Wolford RD, Eddington DK, Rabinowitz WM (1991) Better speech recognition with cochlear implants. *Nature* 352:236–238.
- Wilson BS, Lawson DT, Finley CC, Wolford RD (1993) Importance of patient and processor variables in determining outcomes with cochlear implants. *J Speech Hear Res* 36:373–379.
- Wilson BS, Finley CC, Zerbi M, Lawson DT (1994) Speech processors for auditory prostheses: temporal representations with cochlear implants—modeling, psychophysical, and electrophysiological studies. Seventh Quarterly Progress Report, NIH project N01-DC-2-2401, Neural Prosthesis Program, National Institutes of Health, Bethesda, MD. (This report is available online at <http://scientificprograms.nidcd.nih.gov/npp/index.html>.)
- Wilson BS, Lawson DT, Zerbi M (1995) Advances in coding strategies for cochlear implants. *Adv Otolaryngol Head Neck Surg* 9:105–129.
- Wilson BS, Finley CC, Lawson DT, Zerbi M (1997a) Temporal representations with cochlear implants. *Am J Otol* 18:S30–S34.
- Wilson BS, Zerbi M, Finley CC, Lawson DT, van den Honert C (1997b) Speech processors for auditory prostheses: relationships between temporal patterns of nerve activity and pitch judgments for cochlear implant patients. Eighth Quarterly Progress Report, NIH project N01-DC-5-2103, Neural Prosthesis Program, National Institutes of Health, Bethesda, MD. (This report is available online at <http://scientificprograms.nidcd.nih.gov/npp/index.html>.)
- Wilson BS, Wolford RD, Lawson DT (2000) Speech processors for auditory prostheses: effects of changes in stimulus rate and envelope cutoff frequency for CIS processors. Sixth Quarterly Progress Report, NIH project N01-DC-8-2105, Neural Prosthesis Program, National Institutes of Health, Bethesda, MD. (This report is available online at <http://scientificprograms.nidcd.nih.gov/npp/index.html>.)
- Wilson BS, Lawson DT, Müller JM, Tyler RS, Kiefer J (2003a) Cochlear implants: some likely next steps. *Annu Rev Biomed Eng* 5:207–249.
- Wilson BS, Wolford RD, Lawson DT, Schatzer R (2003b) Speech processors for auditory prostheses: additional perspectives on speech reception with combined electric and acoustic stimulation. Third Quarterly Progress Report, NIH project N01-DC-2-1002, Neural Prosthesis Program, National Institutes of Health, Bethesda, MD. (This report is available online at <http://scientificprograms.nidcd.nih.gov/npp/index.html>.)
- Wouters J, Vanden Berghe J (2001) Speech recognition in noise for cochlear implantees with a two-microphone monaural adaptive noise reduction system. *Ear Hear* 22:420–430.
- Wouters J, Geurts L, Peeters S, Vanden Berghe J, van Wieringen A (1998) Developments in speech processing for cochlear implants. *Acta Otorhinolaryngol Belg* 52:129–132.
- Zeng F-G (2002) Temporal pitch in electric hearing. *Hear Res* 174:101–106.
- Zeng F-G, Shannon RV (1992) Loudness balance between acoustic and electric stimulation. *Hear Res* 60:231–235.
- Ziese M, Stutzel A, von Specht H, Begall K, et al. (2000) Speech understanding with the CIS and the n-of-m strategy in the MED-EL COMBI 40+ system. *ORL J Otorhinolaryngol Relat Spec* 62:321–329.

- Zimmerling MJ, Hochmair ES (2002) EAP recordings in Ineraid patients—correlations with psychophysical measures and possible implications for patient fitting. *Ear Hear* 23:81–91.
- Zwolan TA, Kileny PR, Ashbaugh C, Telian SA (1996) Patient performance with the Cochlear Corporation “20 + 2” implant: bipolar versus monopolar activation. *Am J Otol* 17:717–723.
- Zwolan T, Kileny PR, Smith S, Mills D, Koch D, Osberger MJ (2001) Adult cochlear implant patient performance with evolving electrode technology. *Otol Neurotol* 22:844–849.

Two New Directions in Speech Processor Design for Cochlear Implants

Blake S. Wilson, Reinhold Schatzer, Enrique A. Lopez-Poveda, Xiaoan Sun, Dewey T. Lawson, and Robert D. Wolford

Two new approaches to the design of speech processors for cochlear implants are described. The first aims to represent “fine structure” or “fine frequency” information in a way that it can be perceived and used by patients, and the second aims to provide a closer mimicking than was previously possible of the signal processing that occurs in the normal cochlea.

(*Ear & Hearing* 2005;26;73S–81S)

Although great progress has been achieved in the design and performance of cochlear implant systems, much remains to be done. Patients with the best results still do not hear as well as listeners with normal hearing, particularly in demanding situations such as speech presented in competition with other talkers or noise at typical signal-to-competitors ratios, for example, +5 dB. Users of standard unilateral implants do not have much access to music and other sounds that are more complex than speech. Even the “star” performers report a need for great concentration in attaining their high scores in speech-reception tests. Such a cognitive load must separate implant listeners from their normal-hearing peers. Perhaps most important, though, is the fact that scores still vary widely across patients for difficult tests, such as recognition of monosyllabic words, with any of the implant systems now in widespread use.

Quite recently, large steps forward have been made with use of bilateral cochlear implants (e.g., Müller et al., 2002) and with combined electric and acoustic stimulation (EAS) of the auditory system (e.g., von Ilberg et al., 1999), the latter for patients with some residual (low frequency) hearing either ipsilateral or contralateral to a cochlear implant. The gains are mostly seen for speech reception in noise. In addition, use of relatively high rates of

pulsatile stimulation, in conjunction with at least eight electrode sites and good current sources, has produced significant improvements in performance over prior approaches, again most notably for speech reception in noise (e.g., Frijns et al., 2003; Koch et al., 2004).

Additional approaches are being developed. Work is underway in our laboratories and elsewhere to (a) represent “fine structure” or “fine frequency” information in a way that it can be perceived and used by patients, and (b) provide a closer mimicking than was previously possible of the signal processing that occurs in the normal cochlea. These new approaches may support further gains in performance, either alone or in combination with other approaches.

The primary purpose of this report is to provide an overview of design considerations for these two new approaches. In addition, some preliminary results from studies in progress to evaluate one of the approaches are mentioned.

IMPORTANCE OF FINE STRUCTURE INFORMATION

The mathematician David Hilbert showed that signals can be decomposed into slowly varying envelopes modulating high-frequency carriers (Hilbert, 1912). An example of such a decomposition is presented in Figure 1. The instantaneous phase, or frequency (first derivative of the phase signal), of the carrier varies continuously. Hilbert described the carrier as the “fine structure” (FS) portion of the original signal.

Smith and coworkers (2002) have investigated the relative importance of envelope and FS information for speech reception, melody recognition, and sound localization. They created “auditory chimeras” by first processing two separate inputs with identical banks of bandpass filters and then multiplying the FS carriers derived from one bank of filters with the envelope signals derived from the other bank of filters. The modulated carriers were then summed to form the output. Thus, the chimeras presented conflicting cues—the envelope variations in a given number of bands for one sound, versus the FS variations in the same bands for another sound. Pairings of inputs included sen-

RTI International, Research Triangle Park, North Carolina (B.S.W.); the Division of Otolaryngology, Head and Neck Surgery, Department of Surgery, Duke University Medical Center, Durham, North Carolina (B.S.W., D.T.L.); the Center for Auditory Prosthesis Research, RTI International, Research Triangle Park, North Carolina (R.S., X.S., D.T.L., R.D.W.); and Laboratory of Neurobiology of Hearing, Instituto de Neurociencias de Castilla y León, Universidad de Salamanca, Avda. Alfonso X “El Sabio” s/n, 37007 Salamanca, Spain (E.A.L.-P.).

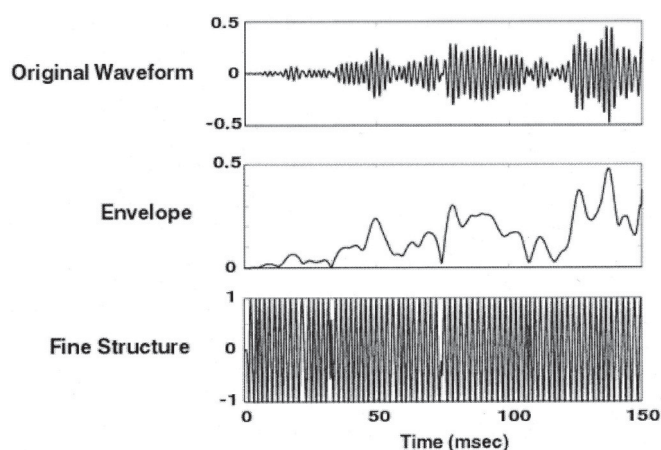

Fig. 1. Decomposition of a signal using the Hilbert transform. (Illustration from the website of Smith and colleagues, <http://epl.meei.harvard.edu/~bard/chimera/>; also see Smith et al., 2002.)

tences versus noise, sentences versus different sentences, melodies versus different melodies, and sentences with an interaural time delay (ITD) corresponding to a sound image at the left versus the same or different sentences with an ITD corresponding to a sound image at the right.

The sound heard or correctly identified by subjects with normal hearing depended on the type(s) of sounds in each pairing and on the number of processing channels (bands). Speech was identified by its envelope information for eight or more channels, whereas the FS information was more important for one or two channels. Both envelope and FS information contributed to sentence recognition for intermediate numbers of channels. Melodies were recognized almost exclusively by their FS information up to 32 channels. Envelope cues became dominant at 48 and 64 channels. Lateralization of sentences was difficult with a small number of channels but improved with increasing numbers up to the tested limit of 32. Lateralization was cued by the FS information in all cases.

These findings indicate the importance of the FS information for speech reception using fewer than about 8 processing channels and for music reception using fewer than about 40 channels. In addition, they indicate that ITD cues may be represented by the FS information but not the envelope information, for any number of channels up to (at least) 32.

Present-day electrode arrays for cochlear implants appear to support no more than four to eight independent channels, as indicated by a lack of increases in speech reception scores when the number of processing channels and associated sites of stimulation is increased beyond that number (Fishman et al., 1997; Friesen et al., 2001; Garnham et al., 2002; Lawson et al., Reference Note 1; Wilson,

1997). In this 4 to 8 range, both envelope and FS information contribute to speech recognition. Music is conveyed almost solely by FS cues.

The importance of the FS information seems indisputable, given the maximum number of effective channels with current implant devices. The question is, how can this information be presented in a way that it can be perceived and utilized by the patient?

PRESENT PROCESSING STRATEGIES FOR IMPLANTS

The continuous interleaved sampling (CIS), advanced combination encoder (ACE), spectral peak (SPEAK), *n*-of-*m*, and other processing strategies now in use for cochlear implants extract envelope signals from contiguous bandpass filters, which span the overall frequency range of speech and other inputs [see Wilson (2004), for detailed descriptions of these various strategies]. The envelope signals are used to determine patterns of stimulation in the implant. Thus, only the processed envelope information is presented to the user, and most or all FS information is discarded at the envelope-extraction stage.

In CIS processors, for instance, envelope signals are derived at the outputs of the bandpass filters and those derived signals are compressed into the narrow dynamic range of electrically evoked hearing (Fig. 2). The compressed signals modulate trains of pulses with a constant pulse rate. Frequency variations of signals within each bandpass are not represented in the stimuli unless (a) the cutoff frequency of the low-pass filter in the envelope detector is comparable to or higher than frequencies in the bandpass, (b) a half-wave rectifier is used instead of a full-wave rectifier in the envelope detector to avoid frequency-doubling effects, and (c) the pulse rate of the stimuli for the channel is sufficiently high to represent the relatively rapid variations in the modulation without significant distortions. Typical implementations of the CIS and the other processors use cutoff frequencies for the envelope detectors in the range of 200 to 400 Hz. This allows representations of the fundamental frequency for voiced speech sounds, voiced versus unvoiced distinctions, and rapid transient events in speech such as those associated with stop consonants. However, little or no information about frequencies within channels, even the channel with the lowest center frequency, is represented.

A variation of CIS, called "HiRes," uses high pulse rates and an effective cutoff for the envelope detectors at half the rates (Koch et al., 2004; Wilson, 2004). In addition, the detectors use a half-wave

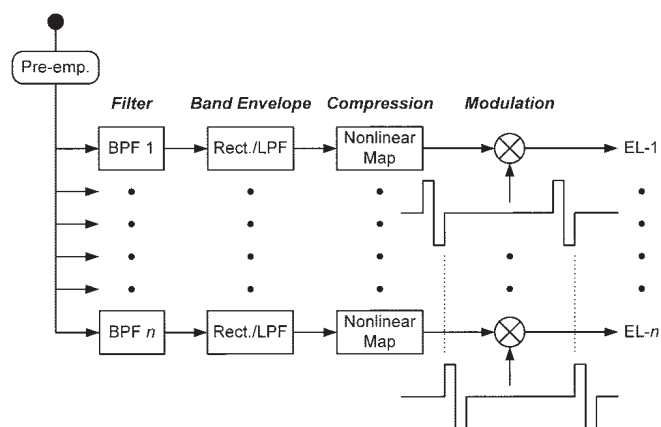

Fig. 2. Block diagram of the continuous interleaved sampling (CIS) strategy. The strategy uses a preemphasis filter (Pre-emp.) to attenuate strong components in speech below 1.2 kHz. The preemphasis filter is followed by multiple channels of processing. Each channel includes stages of bandpass filtering (BPF), envelope detection, compression, and modulation. The envelope detectors generally use a rectifier (Rect.) and low-pass filter (LPF). A Hilbert Transform or a half-wave rectifier without the low-pass filter also may be used. Carrier waveforms for two of the modulators are shown immediately below the two corresponding multiplier blocks (circles with a “x” mark within them). Outputs of the multipliers are directed to intracochlear electrodes (EL-1 to EL-*n*), via a transcutaneous link or a percutaneous connector. (Diagram adapted from Wilson et al., 1991.)

rectifier. The rates may be as high as about 2800 pulses/sec for each channel and associated electrode, for a 16-channel implementation that uses nonsimultaneous stimulation across electrodes. The rate can be almost doubled by using an implementation that presents pulses for two of the channels to their respective electrodes simultaneously. FS information may be presented for frequencies up to about 1400 Hz for the nonsimultaneous mode and up to about 2800 Hz for the “paired pulses” mode.

Another way in which FS information might be presented is to represent directly the “analog” outputs of the bandpass filters at the electrodes, as in the compressed analog (CA) or simultaneous analog stimulation (SAS) strategies (see full descriptions in Wilson, 2004). FS information is not discarded in the processing with these strategies.

Although FS information may be presented with the HiRes, CA, or SAS strategies, implant patients may not be able to perceive much if any of it. In particular, most patients do not perceive differences in the frequency of stimulation at individual electrodes as differences in pitch above a “pitch saturation limit” of about 300 Hz (e.g., Zeng, 2002). Thus, frequency variations may be presented by these strategies, but they cannot be utilized by the patients for any but the lowest frequencies. For loud-

ness-balanced stimuli, a sinusoid at 500 Hz does not sound any different to most patients than a 300 Hz sinusoid. Similarly, modulation of a pulse train at 500 Hz is not discriminable from modulation at 300 Hz.

A further concern with strategies that use simultaneous stimulation across electrodes is that such stimulation may exacerbate interactions among electrodes and thereby reduce the salience of channel-related cues (Favre and Pelizzone, 1993; Middlebrooks, 2004; White et al., 1984; Wilson, 2004). Thus, any gain produced through presentation of FS information may be counteracted, or more than counteracted, by an increase in electrode interactions.

This possible tradeoff between a representation of FS information on the one hand, and increased electrode interactions on the other hand, may vary across patients. Some patients have relatively high pitch saturation limits and therefore may have greater access than others to the presented FS information. In addition, some patients have relatively low electrode interactions, perhaps due to excellent survival of neural elements in the implanted cochlea or close placements of electrodes next to excitable tissue or both. Patients with low interactions and high pitch saturation limits may achieve especially good results with the CA, SAS, or “paired pulses” HiRes strategies. Patients with high pitch saturation limits only may receive the greatest benefit from the nonsimultaneous pulses version of HiRes and other implementations of CIS that use high cutoff frequencies for the envelope detectors.

In general, though, representation of FS information as variations in frequencies or rates of stimulation at the electrodes seems limited. Most patients will not have any access to the information above about 300 Hz, and no patient will have access to it above about 1000 Hz. In addition, the difference limens for frequencies below the limit are very much poorer for implant patients than for listeners with normal hearing, usually more than 10 times worse (e.g., Baumann & Nobbe, 2004; Zeng, 2002). Thus, even for frequencies below the pitch saturation limit, patients may be able to perceive only gross features in the presented FS information.

The typical pitch saturation limit of 300 Hz just reaches or barely exceeds the lower cutoff frequency for the bandpass filter with the lowest center frequency in the various processors mentioned above. With the possible exception of this lowest band, no information about frequency components within the bands of the filter bank will be available to most implant users with “temporal” representations of FS information.

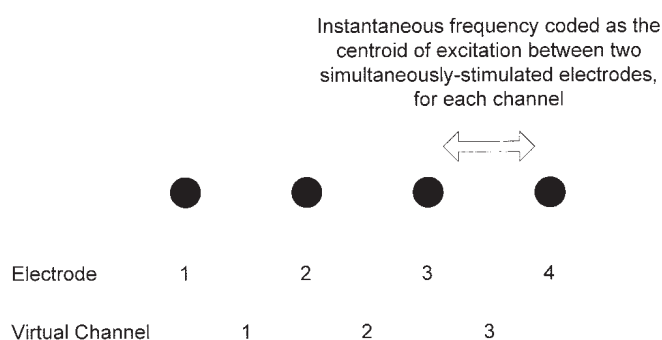

Fig. 3. Representation of fine-structure or fine-frequency information using current steering or “virtual channels.” The centroid of excitation between electrodes along the length of the cochlea is shifted continuously, as instructed by an instantaneous frequency signal derived using a Hilbert transform or other means (e.g., a simple peak or zero-crossing detector) for each bandpass channel. Only four electrodes are illustrated. Present-day implants in widespread use include 12 to 22 electrodes or electrode positions. Adjacent electrodes are stimulated simultaneously, with an amplitude selected for each of the electrodes to place the centroid in the desired spot. Stimulation across such pairs of electrodes, and across channels, is nonsimultaneous, as in standard continuous interleaved sampling (CIS) processors, to avoid or minimize interactions.

SOME ALTERNATIVES FOR REPRESENTING FS INFORMATION

Possibilities for better representations of FS information include (a) the acoustic stimulation part of combined EAS and (b) fine adjustments in the sites of stimulation along the electrode array of an implant, as instructed by an instantaneous frequency signal for each channel. The acoustic stimulation part of combined EAS may be perceived in a way similar to that of low-frequency sounds in normal hearing. In such a case, FS information would be fully or largely available to the user up to the frequency limit of the residual hearing, typically 500 to 1000 Hz for EAS patients. Fine resolution of frequencies in the low-frequency range can support a high level of music reception (e.g., Gantz et al., 2004; Gfeller et al., 2002). In addition, the FS information in the low-frequency band, when combined with electric stimuli for a coarse representation of higher frequencies, may support especially high levels of speech reception in noise (Gantz et al., 2004; Kiefer et al., 2005; Turner et al., 2004; Wilson et al., Reference Note 2).

Fine adjustments in sites of stimulation might be made using virtual channels (e.g., Wilson et al., 1994), as illustrated in Figure 3, or through selection of a particular electrode among many. Coding by place of stimulation might be far more effective than coding by frequency or rate of stimulation, as de-

scribed above. Coding by place may allow representation of frequencies within bands for all channels of the implant processor, not just the lowest band (at best). Such coding may be beneficial for EAS patients as well, in that FS information might be conveyed for all parts of the spectrum, using acoustic stimulation and residual hearing for the low-frequency part of the spectrum and place coding with electric stimuli for higher-frequency parts of the spectrum. This might be (even) more effective than combined EAS as presently applied, without the place coding for the higher frequencies.

A further alternative for representing FS information has been described by Stickney et al. (2002) and Zeng and coworkers (Reference Note 3). It involves frequency modulation of the carrier pulses for a CIS-like processor to reflect the instantaneous frequency for each bandpass channel. The mean rate is quite low compared with the rates of (fixed rate) carriers used in standard CIS processors. This adjustment is made so that differences in rate produced by the frequency modulation can be perceived by implant patients, that is, the maximum rate for any one channel cannot exceed the pitch saturation limit if it is to be perceived as distinct from lower rates. This approach also might present the FS information in a way that it can be perceived, although the information is transposed to much lower frequencies and differentially so across channels. Such transformations may or may not degrade the representation (and perception) of the FS information.

A general concern with the approach is that use of relatively low carrier rates in standard CIS processors produces reductions in performance (e.g., Loizou et al., 2000). Thus, a tradeoff may exist between representation of FS information on the one hand versus deleterious effects of low carrier rates on the other hand.

Studies are underway in our laboratories to evaluate the possibilities mentioned above for place coding of FS information. The subjects include users of the Ineraid device and users of an experimental version of the Nucleus device, which includes a Contour electrode array and a percutaneous connector. The percutaneous access available with both of these devices allows current steering between simultaneously stimulated electrodes as required for the construction of virtual channels. The high number of intracochlear electrodes in the Nucleus device (22 versus the six of the Ineraid device) also allows evaluation of coding through selection of one electrode among at least two for each processing channel, at each update for the channel. Thus, the “virtual channel” approach is being evaluated in tests with both groups of subjects, and the “electrode

selection” approach is being evaluated in tests with the Nucleus subjects. Results from these various studies should be available in the near future.

Studies also are underway at the University of California at Irvine, under the able direction of Professor Zeng (Zeng, 2004a, 2004b; Zeng et al., Reference Note 3). Results from those studies should be available soon as well, and should shed light on the likely tradeoff mentioned above.

Additional approaches for representing FS information have been suggested. For example, Rubinstein et al. (1999) and Litvak et al. (2003) have suggested that improving the neural representation of relatively rapid temporal variations using “conditioner pulses” might in turn improve perception of frequency changes within channels. To the extent that perception is improved, this also might be an effective approach. To date, however, and to our knowledge, no such improvements have been demonstrated. (Dynamic range is increased with the use of conditioner pulses, but improvements in frequency discrimination, or extensions in the pitch saturation limit, have yet to be demonstrated.)

In our view, an effective representation of FS information could lead to a breakthrough in implant design and performance. Several possibilities are being pursued. Among these, we believe representations based on place coding, or place coding in conjunction with the acoustic-stimulation part of combined EAS, have the greatest promise at this time.

CLOSER MIMICKING OF PROCESSING IN THE NORMAL COCHLEA

Recent advances in electrode and stimulus design have increased the level of control that implants can exert over spatial and temporal patterns of responses in the auditory nerve. The advances include perimodiolar electrode arrays, use of high-rate carriers or high-rate conditioner pulses, and current steering to produce virtual channels or sites of stimulation between adjacent electrodes. All but the last of these advances are reviewed in Wilson et al. (2003). Virtual channels and their construction are described in Wilson et al. (1994).

The higher levels of control may be exploited to produce a closer mimicking with implants of the signal processing that occurs in the normal cochlea. The target for such an approach is illustrated in Figure 4, which shows a simplified block diagram of the normal auditory periphery. The processing includes (1) highly nonlinear filtering of the mechanical input by the basilar membrane (BM) and associated structures, including level-dependent tuning and compression, which is produced by a local feed-

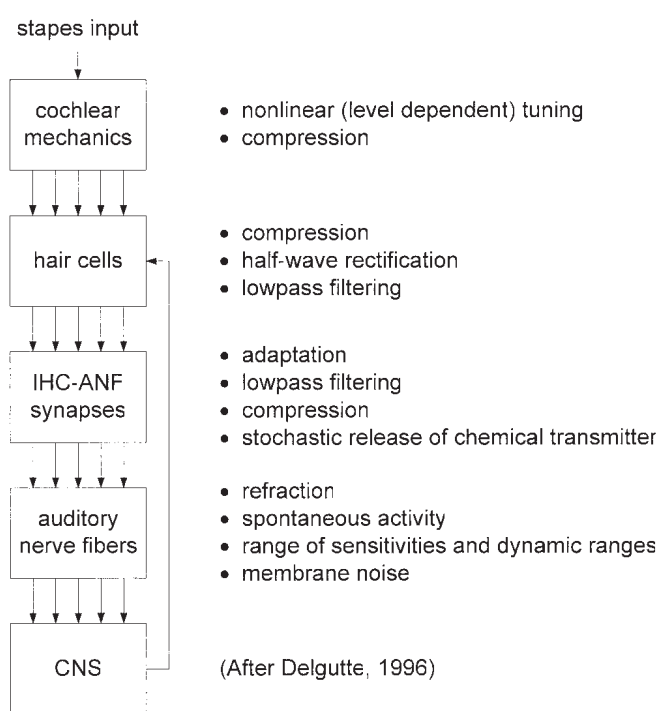

Fig. 4. Simplified block diagram of the normal auditory periphery. IHC-ANF, inner hair cell–auditory nerve fiber. (Diagram adapted from Delgutte, 1996.)

back loop involving electromotile contractions of the outer hair cells; (2) rectification, low-pass filtering, and a further compression in the transduction of BM movements to membrane potentials at the inner hair cells (IHCs); (3) a further noninstantaneous compression and adaptation at the synapses between IHCs and adjacent type I fibers of the auditory nerve; (4) random release of chemical transmitter substance at the base of the IHCs into the synaptic cleft even in the absence of stimulation, which gives rise to spontaneous activity in auditory neurons and statistical independence in discharge patterns among neurons; (5) the inability of single neurons to respond immediately after prior stimulation due to refractory effects; (6) a wide distribution of spontaneous rates among the 10 to 20 fibers that innervate each IHC; (7) a wide distribution of thresholds and dynamic ranges of those fibers, which is related to the distribution of spontaneous activities among the fibers (e.g., fibers with low rates have high thresholds and relatively wide dynamic ranges, and fibers with high rates have low thresholds and relatively narrow dynamic ranges); (8) feedback control from the central nervous system that can alter the response properties of the hair cells.

References and additional details about the processing in the normal auditory periphery are presented in Wilson et al. (2003).

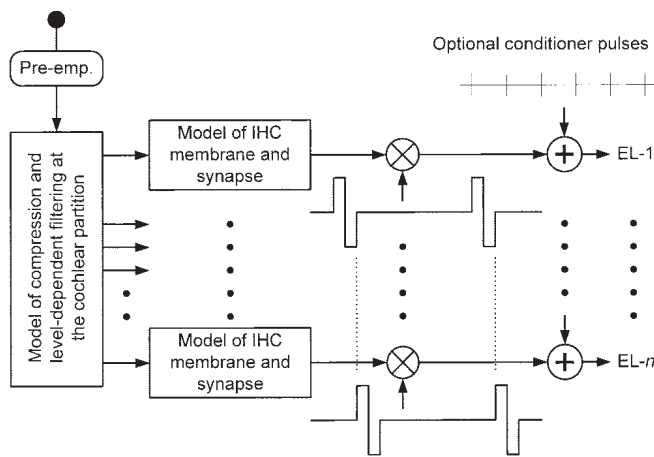

Fig. 5. Suggested processor structure for a closer mimicking of normal auditory functions. Possible models to be incorporated into a speech processor design are listed beneath the corresponding blocks. Pre-emp, Preemphasis filter; IHC, inner hair cell; EL, electrode. This diagram is reproduced from Wilson et al. (2003), with the permission of the Annual Reviews.

Present processing strategies for cochlear implants, such as the CIS strategy shown in Figure 2, provide only a very crude approximation to processing in the normal cochlea. For example, a bank of linear bandpass filters is used instead of the nonlinear and coupled filters that would model normal auditory function. Also, a single nonlinear map is used in the CIS and other strategies to produce the overall compression that the normal system achieves in multiple steps. The compression in CIS and other processors is instantaneous, whereas compression at the IHC/neuron synapse in normal hearing is noninstantaneous, with large adaptation effects.

Deng & Geisler (1987), among others, have shown that nonlinearities in BM filtering greatly enhance the neural representation of speech sounds presented in competition with noise. Similarly, findings of Tchorz & Kollmeier (1999) have indicated the importance of adaptation at the IHC/neuron synapse in representing temporal events or markers in speech, especially for speech presented in noise. Aspects of the normal processing are responsible for the sharp tuning, high sensitivity, wide dynamic range, and high resolution of normal hearing. Those aspects, and indeed entire steps and feedback loops, are missing in the processing used today for cochlear implants.

An approach for providing a much closer approximation to normal processing is suggested in Figure 5. The idea is to use better models of the normal processing, whose outputs may be fully or largely conveyed through the higher levels of neural control now available with implants.

Comparison of Figures 2 and 5 shows that in the new structure, a model of nonlinear filtering is used instead of the bank of linear filters, and a model of the IHC membrane and synapse is used instead of an envelope detector and nonlinear mapping function. Note that the mapping function is not needed in the new structure, because the multiple stages of compression implemented in the models should provide the overall compression required for mapping the wide dynamic range of processor inputs onto stimulus levels appropriate for neural activation. (Some scaling may be needed, but the compression functions should be at least approximately correct.) The compression achieved in this way would be much more analogous to the way it is achieved in normal hearing.

Conditioner pulses or high carrier rates may be used if desired, to impart spontaneous-like activity in auditory neurons and stochastic independence among neurons (Rubinstein et al., 1999; Wilson et al., 1997). This can increase the dynamic range of auditory neuron responses to electrical stimuli, bringing it closer to that observed for normal hearing using acoustic stimuli. Stochastic independence among neurons also may be helpful in representing rapid temporal variations in the stimuli at each electrode, in the collected (ensemble) responses of all neurons in the excitation field (e.g., Parnas, 1996; Wilson et al., 1997). (This does not necessarily mean that the represented variations can be perceived, as noted before in the sections on "fine structure" processors.)

The approach shown in Figure 5 is intended as a move in the direction of closer mimicking. It does not include feedback control from the CNS, and it does not include a way to stimulate fibers close to an electrode differentially, to mimic the distributions of thresholds and dynamic ranges of the multiple neurons innervating each IHC in the normal cochlea. However, it does have the potential to reinstate other important aspects of the normal processing, including details of filtering at the BM and associated structures, and including non-instantaneous compression and adaptation at the IHCs and their synapses.

IMPLEMENTATIONS OF "CLOSER MIMICKING" PROCESSORS

Studies are underway in our laboratories to evaluate various implementations of processors designed to provide a closer approximation than before to normal cochlear functions. We are proceeding in steps, including (a) substitution of a bank of dual-resonance, nonlinear (DRNL) filters (Lopez-Poveda & Meddis, 2001; Meddis et al., 2001) for the bank of

linear filters used in a standard CIS processor; (b) substitution of the Meddis IHC model (Meddis, 1986, 1988) for the envelope detector and for some of the compression ordinarily provided by the nonlinear mapping table in a standard CIS processor; and (c) combinations of (a) and (b) and fine tuning of the interstage gains and amounts of compression at various stages. Work thus far has focused on implementation and evaluation of processors using DRNL filters [step (a)]. For those processors, the envelope detectors and nonlinear mapping tables are retained, but the amount of compression provided by the tables is greatly reduced as substantial compression is provided by the DRNL filters. The DRNL filters have many parameters whose adjustment may affect performance. We have started with a set designed to provide a close approximation to filtering along the human BM (Lopez-Poveda & Meddis, 2001) but also are exploring effects produced by manipulations in the parameters, that is, to broaden tuning properties of the filters so that their responses overlap at least to some extent across channels.

In general, the frequency responses of the DRNL filters are much sharper than those of the Butterworth filters used in standard CIS processors, at least for 6 to 12 channels of processing and stimulation and at least for low-to-moderate input levels. Thus, if one simply substitutes DRNL filters for the Butterworth filters without alteration, then substantial gaps will be introduced in the represented spectra of lower-level inputs to the filter bank. Such a “picket fence” effect might degrade performance, even though other aspects of DRNL processing may be beneficial.

Studies to date have included evaluation of DRNL-based processors with broadened filters, as noted above. In addition, we have tested *n-to-m* constructs, in which more than one channel of DRNL processing is assigned to each stimulus site. In one variation, the average of outputs from the multiple channels is calculated and then that average is used to determine the amplitude of a stimulus pulse for a particular electrode. Each DRNL channel includes a DRNL filter, an envelope detector, and a lookup table for compressive mapping of envelope levels onto pulse amplitudes. Thus, the average is the average of mapped amplitudes for the number of DRNL channels assigned to the electrode. We call this the “avg *n-to-m* approach,” in which *m* is the maximum number of electrodes available in the implant and in which *n* is the total number of DRNL channels, an integer multiple of *m*. In another variation, the maximum among outputs from the channels for each electrode is identified and then that maximum is used to determine the amplitude of the

stimulus pulse. We call this the “max *n-to-m* approach.” Both approaches are designed to retain the sharp tuning of DRNL filters using the standard parameters while minimizing or eliminating the “picket fence” effect.

A final approach tested with one subject to date combines DRNL filters with virtual-channel stimulation. The high number of discriminable stimulus sites made available with current steering (and virtual channels) allows a high number of processing channels without having to resort to the *n-to-m* approaches described above.

Results from these preliminary studies are presented in Schatzer et al. (Reference Note 4) and in Wilson et al. (Reference Note 5). The studies described in Schatzer et al. included seven subjects and evaluations of various implementations of DRNL-based processors. The studies described in Wilson et al. included the one subject tested to date with processors that combined DRNL filtering with virtual-channel stimulation. Details about the processor implementations are presented in these references.

In broad terms, the results have been encouraging. Processors using *n-to-m* approaches have in general supported speech reception performance that is immediately on a par with that of the standard CIS processors used in everyday life by the subjects. For the one tested subject, a processor using DRNL filters in combination with virtual-channel stimulation supported significantly better performance than the standard CIS processor, especially for speech reception in noise.

SUMMARY AND CONCLUDING REMARKS

Developments of the “fine structure” and “better mimicking” strategies are in their nascent stages. The importance of the FS information seems indisputable. The question now is, how can the information be presented in a way that it can be perceived? Several promising lines of investigation are in progress. Work also is underway to develop new approaches for providing a much closer replication than was previously possible of signal processing steps in the normal cochlea. Recent advances in electrode and stimulus designs have greatly increased the control implants can exert on patterns of neural responses. This higher level of neural control might be exploited to convey the subtleties of the normal processing. Accurate models of normal processing may be utilized in future speech processor designs, in place of the very crude approximations used in present designs.

As noted in the Introduction, combinations of effective approaches may support better perfor-

mance than the best single approach. Once those most-effective single approaches have been identified, then combinations should of course also be tested.

The future is bright for cochlear implants. Some quite large steps forward have been made in the past few years. We have every prospect for continuing on that path.

ACKNOWLEDGMENTS

Preparation of this paper was supported by NIH project N01-DC-2-1002. Portions of the text were updated or adapted from prior publications (Wilson et al., 2003, 2004) and a publication in press (Wilson et al., Reference Note 6). The paper is based on a Special Guest Address given at the VIII International Cochlear Implant Conference, held in Indianapolis, Indiana, May 10 to 13, 2004.

Address for correspondence: Blake Wilson, RTI International, P.O. Box 12194, Research Triangle Park, NC 27709.

Received December 23, 2004; accepted March 8, 2005

REFERENCES

- Baumann, U., & Nobbe, A. (2004). Pulse rate discrimination with deeply inserted electrode arrays. *Hearing Research*, *196*, 49–57.
- Carney, L. H. (1993). A model for the responses of low-frequency auditory-nerve fibers in cat. *Journal of the Acoustical Society of America*, *93*, 401–417.
- Delgutte, B. (1996). Physiological models for basic auditory percepts. In H. L. Hawkins, T. A. McMullen, A. N. Popper, & R. R. Fay (Eds.), *Auditory Computation* (pp. 157–220). New York: Springer.
- Deng, L., & Geisler, C. D. (1987). A composite auditory model for processing speech sounds. *Journal of the Acoustical Society of America*, *82*, 2001–2012.
- Favre, E., & Pelizzone, M. (1993). Channel interactions in patients using the Ineraid multichannel cochlear implant. *Hearing Research*, *66*, 150–156.
- Fishman, K. E., Shannon, R. V., & Slattery, W. H. (1997). Speech recognition as a function of the number of electrodes used in the SPEAK cochlear implant speech processor. *Journal of Speech, Language, & Hearing Research*, *40*, 1201–1215.
- Friesen, L. M., Shannon, R. V., Baskent, D., & Wang, X. (2001). Speech recognition in noise as a function of the number of spectral channels: Comparison of acoustic hearing and cochlear implants. *Journal of the Acoustical Society of America*, *110*, 1150–1163.
- Frijns, J. H., Klop, W. M., Bonnet, R. M., & Briare, J. J. (2003). Optimizing the number of electrodes with high-rate stimulation of the Clarion CII cochlear implant. *Acta Oto-Laryngologica*, *123*, 138–142.
- Gantz, B. J., Turner, C., & Gfeller, K. (2004). Expanding cochlear implant technology: Combined electrical and acoustical speech processing. *Cochlear Implants International*, *5*(Suppl. 1), 8–14.
- Garnham, C., O'Driscoll, M., Ramsden, R., & Saeed, S. (2002). Speech understanding in noise with a Med-El COMBI 40+ cochlear implant using reduced channel sets. *Ear & Hearing*, *23*, 540–552.
- Gfeller, K. E., Turner, C., Woodworth, G., Mehr, M., Fearn, R., Knutson, J., Witt, S., & Stordahl, J. (2002). Recognition of familiar melodies by adult cochlear implant recipients and normal hearing adults. *Cochlear Implants International*, *3*, 29–53.
- Hilbert, D. (1912). *Grundzüge einer allgemeinen Theorie der linearen Integralgleichungen*. Leipzig: Teubner.
- Kiefer, J., Pok, M., Adunka, O., Stürzebecher, E., Baumgartner, W., Schmidt, M., Tillein, J., Ye, Q., & Gstoettner, W. (2005). Combined electric and acoustic stimulation (EAS) of the auditory system – Results of a clinical study. *Audiology & Neuro-Otology*, *10*, 134–144.
- Koch, D. B., Osberger, M. J., Segel, P., & Kessler, D. (2004). HiResolution and conventional sound processing in the HiResolution bionic ear: Using appropriate outcome measures to assess speech recognition ability. *Audiology & Neuro-Otology*, *9*, 214–223.
- Litvak, L. M., Delgutte, B., & Eddington, D. K. (2003). Improved neural representation of vowels in electric stimulation using desynchronizing pulse trains. *Journal of the Acoustical Society of America*, *114*, 2099–2111.
- Loizou, P. C., Poroy, O., & Dorman, M. (2000). The effect of parametric variations of cochlear implant processors on speech understanding. *Journal of the Acoustical Society of America*, *108*, 790–802.
- Lopez-Poveda, E. A., & Meddis, R. (2001). A human nonlinear cochlear filterbank. *Journal of the Acoustical Society of America*, *110*, 3107–3118.
- Meddis, R. (1986). Simulation of mechanical to neural transduction in the auditory receptor. *Journal of the Acoustical Society of America*, *79*, 702–711.
- Meddis, R. (1988). Simulation of auditory-neural transduction: Further studies. *Journal of the Acoustical Society of America*, *83*, 1056–1063.
- Meddis, R., O'Mard, L. P., & Lopez-Poveda, E. A. (2001). A computational algorithm for computing nonlinear auditory frequency selectivity. *Journal of the Acoustical Society of America*, *109*, 2852–2861.
- Middlebrooks, J. C. (2004). Effects of cochlear-implant pulse rate and inter-channel timing on channel interactions and thresholds. *Journal of the Acoustical Society of America*, *116*, 452–468.
- Müller, J., Schön, F., & Helms, J. (2002). Speech understanding in quiet and noise in bilateral users of the MED-EL COMBI 40/40+ cochlear implant system. *Ear & Hearing*, *23*, 198–206.
- Parnas, B. R. (1996). Noise and neuronal populations conspire to encode simple waveforms reliably. *IEEE Transactions on Biomedical Engineering*, *43*, 313–318.
- Robert, A., & Eriksson, J. L. (1999). A composite model of the auditory periphery for simulating responses to complex tones. *Journal of the Acoustical Society of America*, *106*, 1852–1864.
- Rubinstein, J. T., Wilson, B. S., Finley, C. C., & Abbas, P. J. (1999). Pseudospontaneous activity: Stochastic independence of auditory nerve fibers with electrical stimulation. *Hearing Research*, *127*, 108–118.
- Smith, Z. M., Delgutte, B., & Oxenham, A. J. (2002). Chimaeric sounds reveal dichotomies in auditory perception. *Nature*, *416*, 87–90.
- Stickney, G. S., Nie, K., & Zeng, F.-G. (2002). Realistic listening improved by adding fine structure. *Journal of the Acoustical Society of America*, *112*(Pt. 2), 2355.
- Tchorz, J., & Kollmeier, B. (1999). A model of auditory perception as a front end for automatic speech recognition. *Journal of the Acoustical Society of America*, *106*, 2040–2050.
- Turner, C. W., Gantz, B. J., Vidal, C., Behrens, A., & Henry, B. A. (2004). Speech recognition in noise for cochlear implant listeners: Benefits of residual acoustic hearing. *Journal of the Acoustical Society of America*, *115*, 1729–1735.
- von Ilberg, C., Kiefer, J., Tillein, J., Pfennigdorff, T., & Hartmann, R., Sturzebecher, E., & Klinke, R. (1999). Electric-acoustic stimulation of the auditory system. *ORL Journal of Otorhinolaryngology & Related Specialties*, *61*, 334–340.

- White, M. W., Merzenich, M. M., & Gardi, J. N. (1984). Multichannel cochlear implants: Channel interactions and processor design. *Archives of Otolaryngology – Head & Neck Surgery*, *110*, 493–501.
- Wilson, B. S. (1997). The future of cochlear implants. *British Journal of Audiology*, *31*, 205–225.
- Wilson, B. S. (2004). Engineering design of cochlear implants. In F.-G. Zeng, A. N. Popper, & R. R. Fay (Eds.), *Cochlear Implants: Auditory Prostheses and Electric Hearing* (pp. 14–52). New York: Springer-Verlag.
- Wilson, B. S., Finley, C. C., Lawson, D. T., Wolford, R. D., Eddington, D. K., & Rabinowitz, W. M. (1991). Better speech recognition with cochlear implants. *Nature*, *352*, 236–238.
- Wilson, B. S., Finley, C. C., Lawson, D. T., & Zerbi, M. (1997). Temporal representations with cochlear implants. *American Journal of Otology*, *18*, S30–S34.
- Wilson, B. S., Lawson, D. T., Müller, J. M., Tyler, R. S., & Kiefer, J., et al. (2003). Cochlear implants: Some likely next steps. *Annual Review of Biomedical Engineering*, *5*, 207–249.
- Wilson, B. S., Lawson, D. T., Zerbi, M., & Finley, C. C. (1994). Recent developments with the CIS strategies. In I. J. Hochmair-Desoyer, & E. S. Hochmair (Eds.), *Advances in Cochlear Implants* (pp. 103–112). Vienna: Manz.
- Wilson, B. S., Sun, X., Schatzer, R., & Wolford, R. D. (2004). Representation of fine-structure or fine-frequency information with cochlear implants. *International Congress Series*, *1273*, 3–6.
- Zeng, F.-G. (2002). Temporal pitch in electric hearing. *Hearing Research*, *174*, 101–106.
- Zeng, F.-G. (2004a). Trends in cochlear implants. *Trends in Amplification*, *8*, 1–34.
- Zeng, F.-G. (2004b). Auditory prostheses: Past, present, and future. In F.-G. Zeng, A. N. Popper, & R. R. Fay (Eds.), *Cochlear Implants: Auditory Prostheses and Electric Hearing* (pp. 1–13). New York: Springer-Verlag.
- Zhang, X., Heinz, M. G., Bruce, I. C., & Carney, L. H. (2001). A phenomenological model for the responses of auditory-nerve fibers: I. Nonlinear tuning with compression and suppression. *Journal of the Acoustical Society of America*, *109*, 648–670.

REFERENCE NOTES

- 1 Lawson, D. T., Wilson, B. S., Zerbi, M., & Finley, C. C. (1996). Speech processors for auditory prostheses: 22 electrode percutaneous study: results for the first five subjects. Third Quarterly Progress Report, NIH project NO1-DC-5–2103, Neural Prosthesis Program, National Institutes of Health, Bethesda, MD. (This report is available at <http://www.rti.org/capr/caprqrprs.htm>.)
- 2 Wilson, B. S., Wolford, R. D., Lawson, D. T., & Schatzer, R. (2002). Speech processors for auditory prostheses: additional perspectives on speech reception with combined electric and acoustic stimulation. Third Quarterly Progress Report, NIH project NO1-DC-2–1002, Neural Prosthesis Program, National Institutes of Health, Bethesda, MD. (This report is available at <http://www.rti.org/capr/caprqrprs.htm>.)
- 3 Zeng, F.-G., Nie, K., Stickney, G., Kong, Y.-Y., Chen, H., & Vongphoe, M. (2003). Using fine structure to improve cochlear implant performance. Presented at the *2003 Conference on Implantable Auditory Prostheses*, Pacific Grove, CA, p. 39 in the book of Abstracts.
- 4 Schatzer, R., Wilson, B. S., Wolford, R. D., & Lawson, D. T. (2003). Speech processors for auditory prostheses: Signal processing strategy for a closer mimicking of normal auditory functions. Sixth Quarterly Progress Report, NIH project NO1-DC-2–1002, Neural Prosthesis Program, National Institutes of Health, Bethesda, MD. (This report is available at <http://www.rti.org/capr/caprqrprs.htm>.)
- 5 Wilson, B. S., Schatzer, R., & Lopez-Poveda, E. A. (in press). Possibilities for a closer mimicking of normal auditory functions with cochlear implants. In S.B. Waltzman & J. T. Roland, Jr. (Eds.), *Cochlear Implants*. 2nd Edition. New York: Thieme Medical Publishers.
- 6 Wilson, B. S. (in press). Sound processing strategies. In H. Cooper & L. Craddock (Eds.), *Cochlear Implants: A Practical Guide*. 2nd Edition. London: Whurr.

The Surprising Performance of Present-Day Cochlear Implants

Blake S. Wilson*, *Senior Member, IEEE*, and Michael F. Dorman

Abstract—The speech reception performance of a recipient of the Clarion CII implant was evaluated with a comprehensive set of tests. The same tests were administered for a group of six subjects with normal hearing. Scores for the implant subject were not different from the scores for the normal-hearing subjects, for seven of the nine tests, including the most difficult test used in standard clinical practice. These results are both surprising and encouraging, in that the implant provides only a very crude mimicking of only some aspects of the normal physiology.

Index Terms—Auditory prosthesis, cochlear implant, deafness, hearing, neural prosthesis, speech perception.

I. INTRODUCTION

JUST 30 years ago, cochlear implants provided little more than a sensation of sound and sound cadences. They were useful as an aid to lip reading. Now, a majority of implant users enjoy high levels of speech recognition using hearing alone; indeed, many can use the telephone without difficulty. This is a long trip in a short time, and cochlear implants are widely and correctly regarded as one of the great achievements of modern medicine.

In this paper, we provide a “benchmark” for exactly how far we have come. Specifically, we compare the speech reception performance of a top performer with cochlear implants to the performance of subjects with normal hearing, using identical tests and laboratory procedures.

II. MATERIALS AND METHODS

A. Subjects

The implant subject, subject HR4, noticed a hearing loss at age 23 and by age 34 was completely deaf. He was implanted with a Clarion CII cochlear prosthesis (Advanced Bionics Corp., Sylmar, CA) [1] at age 34, and was tested by us one year later. This prosthesis includes an implementation of the continuous interleaved sampling (CIS) processing strategy [2], a high-bandwidth radio-frequency link for transmitting stimulus information across the skin, current sources with short rise and fall

Manuscript received September 6, 2006; revised January 2, 2007. The work of B. S. Wilson was supported in part by the National Institutes of Health (NIH) through Project N01-DC-2-1002. The work of M. F. Dorman was supported in part by the National Institutes of Health (NIH) through Project 5R01DC000654. *Asterisk indicates corresponding author.*

*B. S. Wilson is with RTI International, Research Triangle Park, NC 27709 USA, and with the Department of Surgery, Duke University Medical Center, Durham, NC 27710 USA (e-mail: bsw@rti.org).

M. F. Dorman is with the Department of Speech and Hearing Science, Arizona State University, Tempe, AZ 85287-0102 USA.

Digital Object Identifier 10.1109/TBME.2007.893505

times, an array of 16 intracochlear electrodes, and (in the version used) a positioning device to place the electrodes next to the inner wall of the scala tympani, the chamber of the cochlea into which the electrode array is inserted for all implant systems now in widespread use.

HR4 was completely deaf prior to his operation, with tactile sensations only at sound pressure levels of 90 dB or higher, for each of the standard audiometric frequencies (at octave steps) from 250 to 8000 Hz. His surgical report indicated a full insertion of the electrode array. Parameters used in his implant system at the time of testing included 16 channels of processing and stimulation; biphasic stimulus pulses with a phase duration of 11 μ s; and a pulse rate of 1449/s at each electrode.

The subjects with normal hearing were selected from an undergraduate population at Arizona State University (ASU). They were paid for their participation. All studies were reviewed and approved by the ASU Institutional Review Board prior to their conduct, and all subjects read and signed an informed consent prior to their participation.

B. Tests

Tests administered for all subjects included recognition of monosyllabic, consonant-nucleus-consonant (CNC) words (50 items); recognition of City University of New York (CUNY) sentences (24 sentences and approximately 200 words, depending on the lists used for each subject); recognition of Hearing in Noise Test (HINT) sentences (250 sentences and 1320 words, presented in quiet); recognition of Arizona Biomedical Institute (AzBio) sentences (40 sentences and approximately 270 words, depending on the lists used); identification of 20 consonants in an /e/-consonant-/e/ context (with 5 repetitions of the 20 in randomized orders); identification of 13 computer-synthesized vowels in a /b/-vowel-/t/ context (with 5 repetitions of the 13 in randomized orders); and recognition of CUNY and AzBio sentences presented in competition with a four-talker babble, at the speech-to-babble ratio (S/B) of +10 dB for the CUNY sentences and that ratio and +5 dB for the AzBio sentences. Additional details about the CNC, CUNY, HINT, and vowel tests are presented in [3]–[6], respectively. Additional details about the AzBio and consonant tests are presented below and in [7].

The AzBio and consonant tests were developed at ASU. The AzBio sentences consist of 500 unique sentences spoken in a conversational style by two male and three female talkers. The sentences are subdivided into lists, and a total of 40 sentences was used in the test with each subject. The AzBio sentences range in length from 6 to 10 words and are more difficult on average than sentences from the CUNY and HINT lists. The

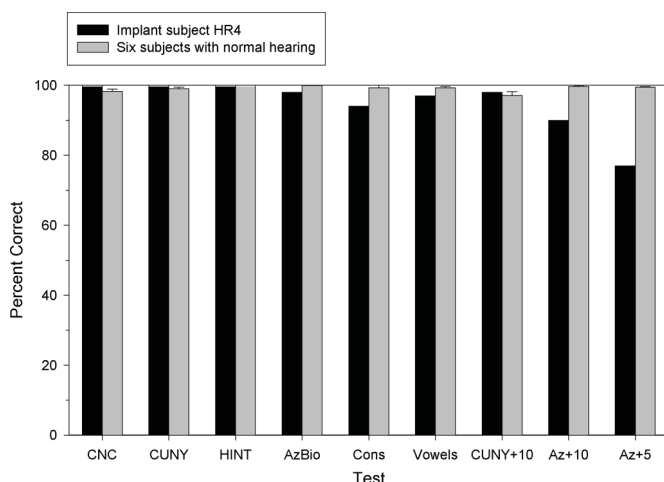

Fig. 1. Percent-correct scores for implant patient HR4 and for six subjects with normal hearing. Means and standard errors of the means are shown for the subjects with normal hearing. Tests included recognition of monosyllabic CNC words; recognition of CUNY sentences; recognition of HINT sentences; recognition of AzBio sentences; identification of consonants (Cons) in an /e/-consonant-/e/ context; identification of vowels (Vowels) in a /b/-vowel-/t/ context; and recognition of CUNY and AzBio (Az) sentences presented in competition with a four-talker babble, at the indicated S/Bs (+5 or +10 dB).

/e/-consonant-/e/ tokens for the consonant test include multiple exemplars of each consonant, produced by a male talker.

The test items were drawn from computer-disk recordings and presented from a loudspeaker at 74-dB SPL (A weighting). Each subject was seated in an audiometric test room, with the speaker placed 1 m in front of the subject. The test items were unknown to the subjects prior to their administration. Scores were calculated as the percentage of correct responses for each test.

In general, the tests were selected to be comprehensive and to challenge the implant subject. They included the most difficult tests used in standard clinical practice to evaluate hearing impairments. They also included tests of even greater difficulty, to provide a greater sensitivity of measures for high-performance subjects. All tests were conducted with hearing alone and without feedback as to correct or incorrect responses.

III. RESULTS

The results for HR4 and the six subjects with normal hearing are presented in Fig. 1. All of the scores for HR4 are high. His scores for speech material presented in quiet, including words, sentences, consonants, and vowels, match or closely approximate the scores for the control group. His score for the most difficult test used in standard clinical practice, recognition of the monosyllabic CNC words, is 100% correct. In contrast, some of his scores for sentences presented in competition with speech babble are worse than normal. Although his score for the CUNY sentences at the S/B of +10 dB is 98% correct, his scores for the AzBio sentences at the S/Bs of +10 dB and +5 dB are below those of the normal-hearing subjects.

Such high scores overall are consistent with HR4's ability to communicate with ease in most listening situations. His speech reception abilities are truly remarkable, abilities that could not have been imagined 20 years ago, even by the most-optimistic proponents of cochlear implants.

IV. DISCUSSION

A battery of tests was administered for a cochlear implant subject and six subjects with normal hearing. The implant subject achieved high scores on all tests, including a score of 100% correct in the recognition of monosyllabic words, the most difficult test given in standard clinical practice to detect deficiencies in speech reception by persons with hearing losses. His scores were at the ceiling of 100% correct or close to it for seven of the nine tests. His scores for the remaining two tests were significantly below 100% correct but still high. The subjects with normal hearing scored at or near the ceiling for all nine tests.

These high scores for HR4 are representative of the very best that can be achieved with present-day cochlear implant systems, at least for a unilateral implant and with electrical stimulation only. Higher scores (for the two tests for which HR4 was not at the ceiling) might possibly be obtained with electrical stimulation on both sides, using bilateral cochlear implants, or with combined electric and acoustic stimulation (EAS) of the auditory system for patients with residual, low-frequency hearing. Within-subject comparisons of bilateral versus unilateral electrical stimulation (e.g., [8]), and of combined EAS versus unilateral electrical stimulation only (e.g., [9]), have demonstrated higher scores for bilateral stimulation and combined EAS respectively, especially for speech presented in competition with noise or a multi-talker babble. Thus, these relatively new approaches may have the potential to produce scores even higher than those achieved by HR4 in the present study, who used a unilateral cochlear implant only.

In any case, the scores for HR4 are spectacularly high and indicate a full restoration of clinically normal function with a sensory prosthesis. Other patients have achieved similarly high scores as well, e.g., one of the subjects in a study by Helms and coworkers [10] achieved a score of 98% correct in the Freiburger monosyllabic word test at the two-year interval. Although these subjects are relatively rare (less than 1% of the implant population), they do provide an existence proof of what is possible with electrical stimulation of the auditory nerve in a totally deafened ear.

A. Significance for Speech Reception of the Intricate Processing in the Normal Cochlea

The very high scores achieved by HR4 and his peers were obtained with a crude and decidedly abnormal input to the central auditory system. The cochlear implant bypasses all structures in the cochlea peripheral to the auditory nerve. In cases like that of HR4, 16 overlapping sectors of the nerve are stimulated with 16 intracochlear electrodes. Other patients have achieved similarly high scores when stimulation is restricted to 6–8 electrodes, e.g., the patient from the Helms *et al.* study mentioned above, who used a COMBI 40 cochlear implant system with its eight channels of processing and stimulation [10]. The spatial specificity of stimulation with implants is much lower than that demonstrated in neural tuning curves for normal hearing [11], especially for monopolar stimulation, which is used in all present-day cochlear implant systems. (Monopolar stimulation is produced with delivery of stimuli between an intracochlear electrode and a remote "reference" electrode outside

of the cochlea, e.g., in the temporalis muscle.) Such broad activation of the nerve with electrical stimuli most likely limits the number of perceptually separable channels to 4–8, even if more than eight intracochlear electrodes are used [12]–[15]. The information presented through the implant is limited to envelope variations in the 16 or fewer frequency bands. For HR4 and others, the upper frequency of envelope variations has been set at 200–700 Hz [16]. A substantial fraction of this information may be perceived by the better patients [17]–[19], and whatever is perceived is sufficient for high levels of speech recognition.

The performance achieved by HR4 brings into question the significance for speech reception of the intricate processing, and the interplay between and among processing steps, that occur in the normal cochlea. The details of the traveling wave of mechanical displacements along the basilar membrane in response to acoustic stimuli [20], and the spatial sharpening of the membrane response by active processes at the outer hair cells [20], [21], are not necessary for effective representations of speech information. Also, the noninstantaneous compression function at the synapse between the inner hair cells and single fibers of the auditory nerve [22] is not necessary. Additional aspects of normal hearing that are not replicated with implants include multiple stages of compression (at the basilar membrane/outer hair cell complex, at the inner hair cells, and at the hair cell/neuron synapse); effects of efferent action on the outer hair cells and other structures in the cochlea [23]; the broad distributions of thresholds for the multiple afferent fibers innervating each inner hair cell [24]; and effects of spontaneous activity in the nerve [25], which is absent or largely absent in the deafened ear [26]–[28].

B. Implications for Other Types of Neural Prostheses

The full restoration of clinically normal function with a cochlear implant, as demonstrated in the present findings for subject HR4, bodes well for the development of other types of sensory neural prostheses. In particular, a sparse and distorted representation at the periphery may be sufficient for restoration of high levels of function for other sensory inputs as well, e.g., visual or vestibular inputs. As with cochlear implants, a putative threshold of the amount and quality of information in the peripheral representation may need to be exceeded before good outcomes can be achieved. However, this threshold may be quite low and a full replication of the exquisite and complex machinery at the periphery is certainly not necessary for the restoration of useful hearing and may not be necessary for the restoration of other senses either.

C. Possibilities for the Future

Tremendous progress has been made in the design and performance of cochlear prostheses. However, much room remains for improvements. Patients with the best results (including the present implant subject HR4) still do not hear as well as listeners with normal hearing, particularly in demanding situations such as speech presented in competition with noise or other talkers. Users of standard unilateral implants do not have much access to music and other sounds that are more complex than speech. Most importantly, speech reception scores still vary

widely across patients for relatively difficult tests, such as recognition of monosyllabic words, with any of the implant systems now in widespread use.

Fortunately, major steps forward have been made recently and many other possibilities for further improvements in implant design and function are on the horizon. Electrical stimulation on both sides with bilateral cochlear implants, and combined EAS for persons with some residual hearing, have been mentioned. These are relatively new approaches, which may well be refined or optimized for still-higher levels of performance. Some of the possibilities for such improvements are just now being explored. Other approaches under investigation—such as reinstatement of spontaneous-like activity in the auditory nerve [29], representation of “fine structure” or “fine frequency” information with implants [30]–[32], or a closer mimicking of the processing that occurs in the normal cochlea [31], [33]—may also produce improvements in performance. These are just some of the possibilities. We fully expect that implants five to ten years from now will be better than today’s implants.

V. CONCLUDING REMARKS

The performance of some recipients of present-day unilateral cochlear implants can closely approximate the performance of subjects with normal hearing across a wide range of measures, including the most difficult test given in standard audiological practice. Such performance by patients is achieved with a decidedly crude and sparse representation at the periphery. This challenges assumptions of hearing theory, that relate to the intricate and exquisite processing in the normal cochlea and auditory nerve and to the putative functions of that processing. The experience with cochlear implants bodes well for the development or further development of other types of sensory prostheses. In particular, surprisingly crude and sparse representations may also support high levels of function for other senses.

ACKNOWLEDGMENT

The authors would like to thank the subjects for their enthusiastic participation.

REFERENCES

- [1] J. H. M. Frijns, J. J. Briaire, J. A. P. M. de Laat, and J. J. Grote, “Initial evaluation of the Clarion CII cochlear implant: Speech perception and neural response imaging,” *Ear Hear.*, vol. 23, pp. 184–197, 2002.
- [2] B. S. Wilson, C. C. Finley, D. T. Lawson, R. D. Wolford, D. K. Eddington, and W. M. Rabinowitz, “Better speech recognition with cochlear implants,” *Nature*, vol. 352, pp. 236–238, 1991.
- [3] G. E. Peterson and I. Lehiste, “Revised CNC lists for auditory tests,” *J. Speech Hear. Disorders*, vol. 27, pp. 62–70, 1962.
- [4] A. Boothroyd, L. Hanin, and T. A. Hnath, Sentence Test of Speech Reception: Reliability, Set Equivalence, and Short Term Learning City University of New York, Speech and Hearing Sciences Research Center, New York, Internal Rep. RCI 10, 1985.
- [5] M. Nilsson, S. D. Soli, and J. A. Sullivan, “Development of the hearing in noise test for the measurement of speech reception thresholds in quiet and in noise,” *J. Acoust. Soc. Am.*, vol. 95, pp. 1085–1099, 1994.
- [6] M. F. Dorman, K. Dankowski, G. McCandless, and L. Smith, “Identification of synthetic vowels by patients using the Symbion multichannel cochlear implant,” *Ear Hear.*, vol. 10, pp. 40–43, 1989.
- [7] A. J. Spahr and M. F. Dorman, “Performance of subjects fit with the Advanced Bionics CII and Nucleus 3G cochlear implant devices,” *Arch. Otolaryngol. Head Neck Surg.*, vol. 130, pp. 624–628, 2004.
- [8] J. Müller, F. Schön, and J. Helms, “Speech understanding in quiet and noise in bilateral users of the MED-EL COMBI 40/40+ cochlear implant system,” *Ear Hear.*, vol. 23, pp. 198–206, 2002.

- [9] J. Kiefer, M. Pok, O. Adunka, E. Sturzebecher, W. Baumgartner, M. Schmidt, and J. Tillein, "Combined electric and acoustic stimulation of the auditory system: Results of a clinical study," *Audiol. Neurootol.*, vol. 10, pp. 134–144, 2005.
- [10] J. Helms, J. Müller, F. Schön, L. Moser, and W. Arnold *et al.*, "Evaluation of performance with the COMBI 40 cochlear implant in adults: A multicentric clinical study," *ORL J. Otorhinolaryngol. Relat. Spec.*, vol. 59, pp. 23–35, 1997.
- [11] C. van den Honert and P. H. Stypulkowski, "Single fiber mapping of spatial excitation patterns in the electrically stimulated auditory nerve," *Hear. Res.*, vol. 29, pp. 195–206, 1987.
- [12] K. E. Fishman, R. V. Shannon, and W. H. Slattery, "Speech recognition as a function of the number of electrodes used in the SPEAK cochlear implant speech processor," *J. Speech. Lang. Hear. Res.*, vol. 40, pp. 1201–1215, 1997.
- [13] B. S. Wilson, "The future of cochlear implants," *Brit. J. Audiol.*, vol. 31, pp. 205–225, 1997.
- [14] M. F. Dorman, P. C. Loizou, L. L. Kemp, and K. I. Kirk, "Word recognition by children listening to speech processed into a small number of channels: Data from normal-hearing children and children with cochlear implants," *Ear Hear.*, vol. 21, pp. 590–596, 2000.
- [15] L. M. Friesen, R. V. Shannon, D. Baskent, and X. Wang, "Speech recognition in noise as a function of the number of spectral channels: Comparison of acoustic hearing and cochlear implants," *J. Acoust. Soc. Am.*, vol. 110, pp. 1150–1163, 2001.
- [16] B. S. Wilson, "Speech processing strategies," in *Cochlear Implants: A Practical Guide*, H. R. Cooper and L. C. Craddock, Eds., 2nd ed. London, U.K.: Whurr, 2006, pp. 21–69.
- [17] M. F. Dorman, P. C. Loizou, J. Fitzke, and Z. Tu, "Recognition of monosyllabic words by cochlear implant patients and by normal-hearing subjects listening to words processed through cochlear implant signal processing strategies," *Ann. Otol. Rhinol. Laryngol.*, vol. 185 Suppl. 2000, pp. 64–66, 2000.
- [18] Q.-J. Fu, "Temporal processing and speech recognition in cochlear implant users," *NeuroReport*, vol. 13, pp. 1635–1639, 2002.
- [19] B. S. Wilson, D. T. Lawson, J. M. Müller, R. S. Tyler, and J. Kiefer, "Cochlear implants: Some likely next steps," *Annu. Rev. Biomed. Eng.*, vol. 5, pp. 207–249, 2003.
- [20] L. Robles and M. A. Ruggero, "Mechanics of the mammalian cochlea," *Physiol. Rev.*, vol. 81, pp. 1305–1352, 2001.
- [21] P. Dallos, "The active cochlea," *J. Neurosci.*, vol. 12, pp. 4575–4585, 1992.
- [22] R. L. Smith, "Cochlear processes reflected in responses of the cochlear nerve," *Acta Otolaryngol.*, vol. 100, pp. 1–12, 1985.
- [23] J. J. Guinan, Jr., "Physiology of olivocochlear efferents," in *The Cochlea*, P. Dallos, A. N. Popper, and R. R. Fay, Eds. New York: Springer, 1996, pp. 435–502.
- [24] M. C. Liberman, "Auditory-nerve response from cats raised in a low-noise chamber," *J. Acoust. Soc. Am.*, vol. 63, pp. 442–455, 1978.
- [25] N. Y. S. Kiang, T. Watanabe, E. C. Thomas, and L. F. Clark, *Discharge Patterns of Single Fibers in the Cat's Auditory Nerve*. Cambridge, MA: The MIT Press, 1965.
- [26] R. Hartmann, G. Topp, and R. Klinke, "Discharge patterns of cat primary auditory nerve fibers with electrical stimulation of the cochlea," *Hear. Res.*, vol. 13, pp. 47–62, 1984.
- [27] N. Y. S. Kiang, E. C. Moxon, and R. A. Levine, "Auditory-nerve activity in cats with normal and abnormal cochleas," in *Sensorineural Hearing Loss*, G. E. W. Wolstenholme and J. Knight, Eds. London, U.K.: J. and A. Churchill, 1970, pp. 241–273.
- [28] R. K. Shepherd and E. Javel, "Electrical stimulation of the auditory nerve. I. Correlation of physiological responses with cochlear status," *Hear. Res.*, vol. 108, pp. 112–144, 1997.
- [29] J. T. Rubinstein, B. S. Wilson, C. C. Finley, and P. J. Abbas, "Pseudospontaneous activity: Stochastic independence of auditory nerve fibers with electrical stimulation," *Hear. Res.*, vol. 127, pp. 108–118, 1999.
- [30] F. G. Zeng, K. Nie, G. S. Stickney, Y. Y. Kong, M. Vongphoe, A. Bhargava, C. Wei, and K. Cao, "Speech recognition with amplitude and frequency modulations," *Proc. Nat. Acad. Sci. USA.*, vol. 102, pp. 2293–2298, 2005.
- [31] B. S. Wilson, R. Schatzer, E. A. Lopez-Poveda, X. Sun, D. T. Lawson, and R. D. Wolford, "Two new directions in speech processor design for cochlear implants," *Ear Hear.*, vol. 26, pp. 73S–81S, 2005.
- [32] Z. M. Smith, B. Delgutte, and A. J. Oxenham, "Chimaeric sounds reveal dichotomies in auditory perception," *Nature*, vol. 416, pp. 87–90, 2002.
- [33] B. S. Wilson, R. Schatzer, and E. A. Lopez-Poveda, "Possibilities for a closer mimicking of normal auditory functions with cochlear implants," in *Cochlear Implants*, S. B. Waltzman and J. T. Roland, Jr., Eds., 2nd ed. New York: Thieme Medical, 2006, pp. 48–56.



Blake S. Wilson (M'80–SM'06) is a Senior Fellow at RTI International, Research Triangle Park, NC, and an Adjunct Professor at the Duke University Medical Center, Durham, NC. He is the inventor of most of the speech processing strategies used with present-day cochlear implants, including the continuous interleaved sampling (CIS), spectral peak picking (e.g., "n-of-m"), and virtual channel strategies, among others. The CIS and n-of-m strategies, or direct descendants of them, are used as the default strategies for all three implant systems now

in widespread use. One of his papers, in the *Nature*, alternates with one other paper as the most highly cited publication in the field of cochlear implants. He has served as the Principal Investigator for 24 projects, including 13 projects for the National Institutes of Health (NIH).

Dr. Wilson and his coworkers have been recognized by many awards and honors, most notably the 1996 Discover Award for Technological Innovation and the American Otological Society's President's Citation for "Major contributions to the restoration of hearing in profoundly deaf persons." He has been the Guest of Honor at 10 international conferences, and has been a keynote or invited speaker at more than 130 others. He has served as the Chair for two large international conferences and as the Co-Chair for two others. Most recently, he was selected to receive the 2007 Distinguished Alumnus Award from the Pratt School of Engineering at Duke.



Michael F. Dorman received the Ph.D. degree in experimental child and developmental psychology (linguistics minor) from the University of Connecticut, Storrs, in 1971.

He is currently a Professor in the Department of Speech and Hearing Science and the Program in Linguistics at Arizona State University, Tempe. He is the author of over 100 publications in areas including speech perception by infants, adults, hearing-impaired listeners and listeners fit with cochlear implants, and also cortical lateralization of function and neural plasticity. His research has been supported by the National Institutes of Health since 1973.

Dr. Dorman is a Fellow of the Acoustical Society of America

Design for a Simplified Cochlear Implant System

Soon Kwan An, Se-Ik Park, Sang Beom Jun, Choong Jae Lee, Kyung Min Byun,
Jung Hyun Sung, Blake S. Wilson, *Senior Member, IEEE*, Stephen J. Rebscher, Seung Ha Oh, and
Sung June Kim*, *Senior Member, IEEE*

Abstract—A simplified cochlear implant (CI) system would be appropriate for widespread use in developing countries. Here, we describe a CI that we have designed to realize such a concept. The system implements 8 channels of processing and stimulation using the continuous interleaved sampling (CIS) strategy. A generic digital signal processing (DSP) chip is used for the processing, and the filtering functions are performed with a fast Fourier transform (FFT) of a microphone or other input. Data derived from the processing are transmitted through an inductive link using pulse width modulation (PWM) encoding and amplitude shift keying (ASK) modulation. The same link is used in the reverse direction for backward telemetry of electrode and system information. A custom receiver-stimulator chip has been developed that demodulates incoming data using pulse counting and produces charge balanced biphasic pulses at 1000 pulses/s/electrode. This chip is encased in a titanium package that is hermetically sealed using a simple but effective method. A low cost metal-silicon hybrid mold has been developed for fabricating an intracochlear electrode array with 16 ball-shaped stimulating contacts.

Index Terms—Auditory prosthesis, cochlear implant system, continuous interleaved sampling, electrode array, hermetic package, neural prosthesis, neural stimulation.

Manuscript received August 9, 2006; revised January 19, 2007. This work was supported in part by the Korea Science and Engineering Foundation (KOSEF) through the Nano Bioelectronics and Systems Research Center (NBS-ERC) of Seoul National University under Grant R11-2000-075-01001-0 and in part by the Nurobiosys Corporation. Electrode development was conducted in collaboration with the Epstein Laboratory at the University of California, San Francisco with support from NIH contracts #NO1-DC-2-1006 and NO1-DC-3-1006. *Asterisk indicates corresponding author.*

S. K. An, S. B. Jun, C. J. Lee, and K. M. Byun are with the School of Electrical Engineering and Computer Science and the Nano Bioelectronics and Systems Research Center, Seoul National University, Seoul 151-744, Korea (e-mail: soonkwan@helios.snu.ac.kr; sangbum@helios.snu.ac.kr; eatspace@helios.snu.ac.kr; calli8@snu.ac.kr).

S. Park is with Nurobiosys Corporation, Seoul 151-050, Korea, and also with the Nano Bioelectronics and Systems Research Center, Seoul National University, Seoul 151-744, Korea (e-mail: psi@helios.snu.ac.kr).

J. H. Sung was with Nurobiosys Corporation, Seoul 151-050, Korea. She now is with BioSpine Co., Ltd, Seoul 133-120, Seoul, Korea (e-mail: prettybug73@hanmail.net).

B. S. Wilson is with RTI International, Research Triangle Park, NC 27709 USA, and also with the Department of Surgery, Duke University Medical Center, Durham, NC 27710 USA (e-mail: bsw@rti.org).

S. J. Rebscher is with the Epstein Laboratory, the Department of Otolaryngology, University of California, San Francisco, CA 93143 USA (e-mail: rebscher@ohns.ucsf.edu).

S. H. Oh is with the Department of Otolaryngology, Seoul National University Hospital, Seoul 110-744, Korea, and also with the Nano Bioelectronics and Systems Research Center, Seoul National University, Seoul 151-744, Korea (e-mail: shaoh@snu.ac.kr).

*S. J. Kim is with the School of Electrical Engineering and Computer Science and the Nano Bioelectronics and Systems Research Center, Seoul National University, Seoul 151-744, Korea (e-mail: kimsj@snu.ac.kr).

Digital Object Identifier 10.1109/TBME.2007.895372

I. INTRODUCTION

A cochlear implant (CI) is a device that can provide a sense of sound to people who are deaf or profoundly hearing-impaired. Significant open-set recognition of speech can be achieved with commercially available multichannel CI systems [1]–[3]. Indeed, a majority of users can converse over the telephone for everyday communications.

Although this performance is spectacular, and can enable users to move from a life of dependence to being strong contributors to society, implants are not available to most of the world's deaf and severely hearing impaired people due to the high cost of these systems. The cost of the implant alone, exclusive of the costs for surgery and rehabilitation, is approximately \$25,000 USD [4]. This is most unfortunate, as approximately 80% of the world's hearing impaired people live in developing countries, with highly limited healthcare budgets and widespread poverty. These people, with annual household incomes that typically range between \$500 and \$1000 USD—or their governments—cannot possibly afford the high cost of currently available implant systems.

This problem was the central theme for a conference held at Zheng-Zhou, He-Nan, China, in 1993. A team of five North American experts was invited to participate in the conference. Following the conference and the knowledge gained from discussions with their Chinese colleagues, they proposed a design for a low cost but effective CI system [5], [6]. This design included a four-channel continuous interleaved sampling (CIS) processor and four independent sets of transmitting and receiving coils connected to a four channel intracochlear electrode array. Such a system does not require an active implant with hermetically packaged electronics and, thus, avoids the high cost of developing and manufacturing the Integrated Circuit (IC) and the packaging required for an active implant. A prototype of the device was built and tested, including tests with implant patients. Speech test scores were high and comparable to the best scores obtainable with any device at the time.

Although this design was promising, the four separate pairs of transmitting and receiving coils were bulky. In addition, voltage waveforms were used for stimulation rather than constant current sources, which are preferred because these sources maintain stimulation levels across changes in electrode impedance, which invariably occur with use of the device. A further weakness of the design in our view was that, without active electronics, there was no possibility for telemetry from the implanted components, including feedback of electrode impedances, integrity of the receiver coils or connections to the stimulating electrodes.

We thought another attempt at designing a simplified implant system was warranted given: 1) the great need for such a device; 2) the weaknesses of a prior design as noted above;

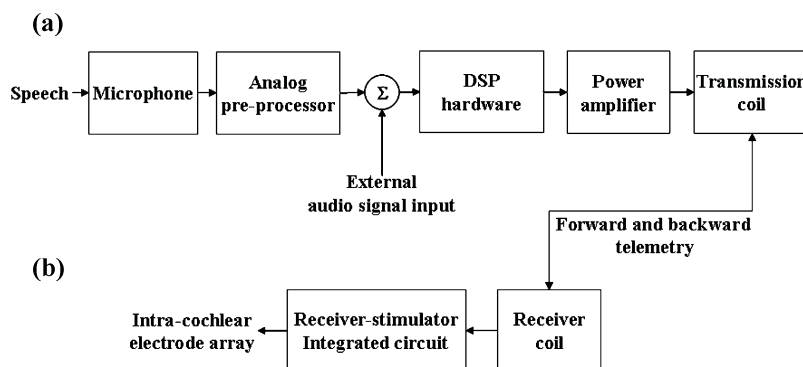

Fig. 1. Block diagram of the CI system. (a) External speech processor, (b) implantable unit.

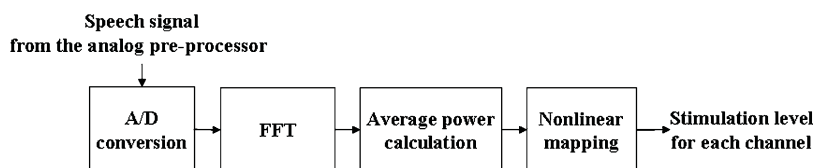

Fig. 2. Functional block diagram of the signal processing performed within the DSP hardware.

3) the tremendous advances in electronics and in our knowledge about the minimum requirements for a high-performance implant system that have occurred since that earlier design, now more than a decade old. We, therefore, initiated such an effort at the Seoul National University, with the help of two members of the original group of experts who participated in the conference in Zheng-Zhou and who were among the designers of the prior system (authors BSW and SJR).

The purpose of this paper is to describe this novel design. This design utilizes active electronics in an implanted receiver-stimulator IC and includes only a single external transmitting coil paired with a single receiving coil. Additionally, it uses 8 channels of processing and stimulation rather than four. Both the external and internal components are much more compact than in the prior design. The new design utilizes modern electronics and was informed by what is now known about the minimal requirements for high performance with CIs.

II. METHODS

The CI system consists of an external speech processor, an implantable unit, and an inductive telemetry link connecting the two. As shown in Fig. 1(a), the external speech processor consists of an analog preprocessor and digital signal processing (DSP) hardware. The implantable unit in Fig. 1(b) consists of a hermetically packaged receiver-stimulator IC and an intra-cochlear array of electrodes. The inductive telemetry link consists of circuits and coils for forward transmission of power and data, and backward transmission of indicators of IC and electrode function.

A. Speech Signal Processing

Results from various studies have shown that increasing the number of channels in a CI beyond 4-8 does not produce measurable improvements in speech perception performance [7]–[9]. Thus, an eight channel system was judged as fully sufficient to guarantee a high level of speech perception.

The system described here uses an 8-channel CIS processing strategy [10]. This strategy is the only one that is included in all currently-available implant systems from the three major manufacturers, and it has been shown to be at least as effective as any other strategy now in widespread use. In addition, CIS is relatively simple to implement compared with other strategies.

The microphone and the external transmitting coil are located in the headset, which is connected to the speech processor. The analog preprocessor consists of a high-pass filter to “flatten” the spectrum of incoming speech [10], a band-pass filter, and an amplifier with automatic gain control. The preprocessor stage receives audio signals from the microphone, or from other audio sources that are connected via an external input socket. The high-pass filter has a single pole at 1.2 kHz and the band-pass filter is a 4th order Butterworth filter with cutoff frequencies of 300 Hz and 8 kHz. The average overall gain of the input stage (which varies with action of the automatic gain controller) is 45 dB.

We note that adopting a commercially available DSP chip is a lower cost option than developing a customized DSP chip. The commercial DSP chip consumes more power than a custom designed one dedicated to the CI, but it offers more flexibility and is vetted as fully reliable through extensive and widespread use.

Fig. 2 shows a functional block diagram of the signal processing performed within the DSP hardware. After digitizing the speech signal, the DSP chip performs frequency analysis using a fast Fourier transform (FFT). The chip then computes the average power of each channel by simple summation and averaging, according to predetermined channel-frequency allocation. Bandpasses for the channels are formed by integration across FFT bins. As an alternative to the FFT method, digital filters could have been implemented using an infinite impulse response (IIR) or finite impulse response (FIR) filter with envelope detection. The FFT approach is more efficient, however, as the total number of computations is substantially lower

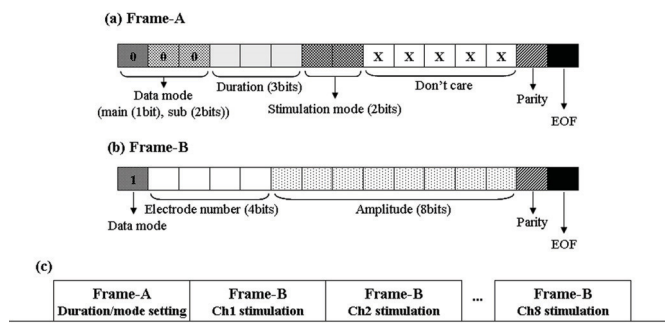

Fig. 3. Data formats. (a) Data frame for pulse duration and stimulation mode setting (Frame-A), (b) data frame for stimulation electrode and pulse amplitude setting, and (c) sequence of data frames for multichannel stimulation.

than in the IIR or FIR approaches. The FFT option also offers flexibility because many functions can be implemented by simple arithmetic operations [11]. For example, parameters such as channel-to-frequency allocation, the order of the filter and overlap of bands between neighboring channels, can be easily controlled by simply changing the number of FFT samples to be averaged and their weights.

B. Communication

Pulse width modulation (PWM) encoding and amplitude shift keying (ASK) modulation and demodulation using pulse counting, are used for the telemetry system. Three kinds of bits are encoded as follows: a logical “one” and “zero” are encoded to have a duty cycle of 75% and 25%, respectively, and an “end-of-frame (EOF)” bit has a 50% duty cycle. Such an encoding method allows easier synchronization and decoding because each bit has a uniform rising edge at its beginning. According to this bit coding scheme, every bit has a high state, which is advantageous for uniform radiofrequency (RF) energy transmission.

Each data frame for forward telemetry consists of 15 bits as shown in Fig. 3. Each frame can contain different types of information for controlling the implant, as illustrated. The first three bits in each frame specify a data mode. The first bit determines whether the frame is for command or stimulation. The next two bits describe the operation as one of the following: duration/stimulation mode, supply voltage check, or impedance check. In sequences of frames, frame-A defines a stimulation mode and a pulse duration Fig. 3(a), and frame-B defines one of sixteen electrode sites and a pulse amplitude for each stimulating channel Fig. 3(b). Prior to the first stimulation, frame-A is delivered, and then multiple frame-Bs are sequentially delivered for multichannel stimulation Fig. 3(c). In frame-A, monopolar and bipolar stimulation modes are encoded to be “00” and “11,” respectively, and the pulse duration is set according to the three duration bits. In each frame-B, electrode site number is encoded with four bits and the stimulation level with eight bits.

Stimulation pulses are presented at the rate of 1000/s/electrode, which requires a sustained transmission data rate of 120 kbps or higher, depending on channel select and pulse duration instructions, in addition to pulse amplitude instructions.

For transcutaneous transmission of PWM encoded data, a class-E tuned power amplifier with high transmission efficiency [12]–[14] is used with amplitude shifted keying (ASK) modulation. The carrier frequency is 2.5 MHz. Alternatively frequency shifted keying (FSK) modulation could have been used, but this requires more complicated components such as a voltage controlled oscillator and low-pass filters with high power dissipation [15]–[17].

For demodulation of the ASK signals, an ordinary envelope detector can be used. However, this method is sensitive to the distance between the two coils. Instead, we count the number of RF cycles for a given burst [18], which allows easy discrimination among 0, 1, or EOF bits. We found that this method is more reliable and far less sensitive to the coil-to-coil distance than the envelope detection method.

In the back telemetry system, information about electrode impedances and receiver-stimulator status such as supply voltages and communication errors are fed back to the DSP chip using load modulation. To obtain information about electrode impedances, the receiver/stimulator samples the voltage difference between an active electrode and a reference electrode (the remote reference for monopolar stimulation or one of the two electrodes for bipolar stimulation). This sampled voltage is sent to the external speech processor via the back telemetry link. Electrode impedances are calculated in the external processor using this information. A voltage sampled at a node in the implant is converted to a proportional pulse duration, during which the quality factor of the receiver resonant circuit is reduced [19]. This information is then read using the DSP chip. Alternatively, we could have included a separate inductive link for the backward communication using the FSK modulation, but this would have increased the complexity and size of the overall implant system.

C. The Receiver-Stimulator Chip

The specialized functions of the receiver/stimulator preclude the use of a generic chip. A customized chip was, thus, developed according to our system architecture. The block diagram of the chip with its peripheral circuit is shown in Fig. 4. Power and data are received at an implanted coil. This coil has a small number of turns compared to the external transmitting coil so that the induced voltage can be lower than a few volts. This small voltage is then stepped up using a small transformer, and a regulated supply of power is obtained.

The stimulator consists of a programmable current source and programmable switches. In the circuit shown in Fig. 5, E1–E16 represent active electrodes in the intracochlear electrode array while R represents the extra-cochlear reference electrode. By controlling the on/off status and duration of the switches, we can easily determine the shape of stimulation pulses and the stimulation mode (monopolar or bipolar). This circuit is designed so that the biphasic pulse is formed by switching from a single set of current sources to ensure charge balance. Passage of any dc current due to the remaining residual charge at the electrodes is precluded with the use of blocking capacitors between the (switched) current source and all electrodes. In addition, all of the active electrodes are grounded between stimulation events,

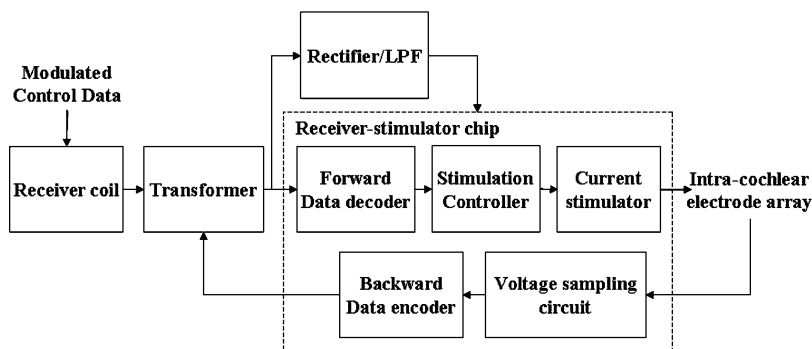

Fig. 4. Block diagram of the receiver-stimulator chip with its peripheral circuit.

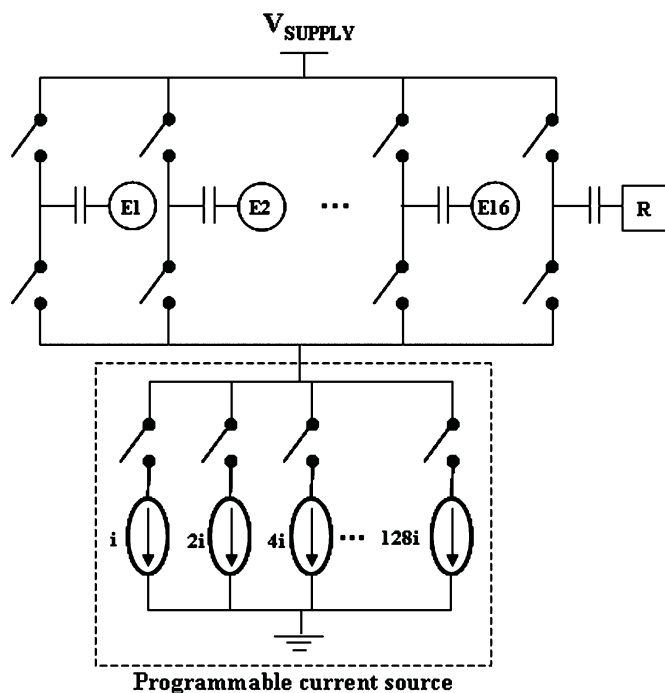

Fig. 5. Concept diagram of the stimulator.

so any residual charge retained in the blocking capacitors can be removed.

D. Hermetic Package

The implanted receiver/stimulator IC needs to be protected from body fluids and mechanical forces. We have developed a titanium (Ti) package, which consists of a biocompatible Ti housing, platinum (Pt) feedthroughs, and a ceramic plate. The feedthroughs connect the electrode array, the reference electrode, and the receiver coil to the receiver-stimulator chip. A ceramic sintering process is used to fix the feedthroughs in the ceramic plate that provides electrical isolation.

Brazing and laser welding techniques are employed to achieve hermetic sealing. A recently developed nano-sized silicon oxide (SiO_2) sol-gel sealing method is used to seal the micro-gaps between the feedthroughs and the ceramic plate [20]. In general, SiO_2 can be a good sealant material. However, the melting point of the covalently bonded SiO_2 crystal is over 1700°C making it difficult for use as a sealant material. Recent

processing developments have demonstrated that the melting point of the SiO_2 can be drastically decreased if it can be made into nano-sized particles and, with this its use becomes practical.

The reliability of implant systems depends strongly on the integrity and lifetime of the hermetic seal. Indeed, a breach in the seal has been the failure point for many prior implant systems, including prior generations of present devices. We believe that the application of SiO_2 as a sealant will increase the quality and lifetime of the seal compared with other materials and methods.

E. Intracochlear Electrode Array

Flame formed ball contacts have been employed since the early stages of cochlear implantation [21], [22]. Such electrodes are still used in clinical applications and are chosen for use in this system because they are simpler to fabricate than the foil type contacts used in some current products.

The electrode array is fabricated in two steps. First, ball-shaped contacts are formed by melting Pt/iridium (Ir) wires with an oxygen/acetylene mini-torch. Second, the wires with the attached balls are molded in a silicone elastomer "carrier." An electrode fabricated by this method requires minimum process steps and has no connective junctions between wires and stimulating sites which could be potential sites of failure. Thus, the fabrication is simpler, highly reliable and less costly compared with other approaches.

We have further increased the production yield over conventional methods by using a metal-silicon hybrid molding system. This metal-silicon hybrid mold is composed of a metal base which holds a micromachined silicon insert. The silicon insert contains holes to precisely locate Pt/Ir contact balls as shown in Fig. 6. The silicon insert is very inexpensive and is discarded after each use to maintain high manufacturing precision. This method increases yield in the molding process and can contribute to lower cost because the metal part of the mold does not need to be a high-precision part.

F. Biocompatibility Testing

To verify the biological safety of the implantable unit, a qualitative cytotoxicity test was conducted based on the ISO 10993-5 and the USP 24-NF19 standards in the Clinical Research Institute of Seoul National University Hospital. NCTC-clone 929 from connective tissues of a 100-day-old mouse was subcultured for over 16 h in a multiple well plate.

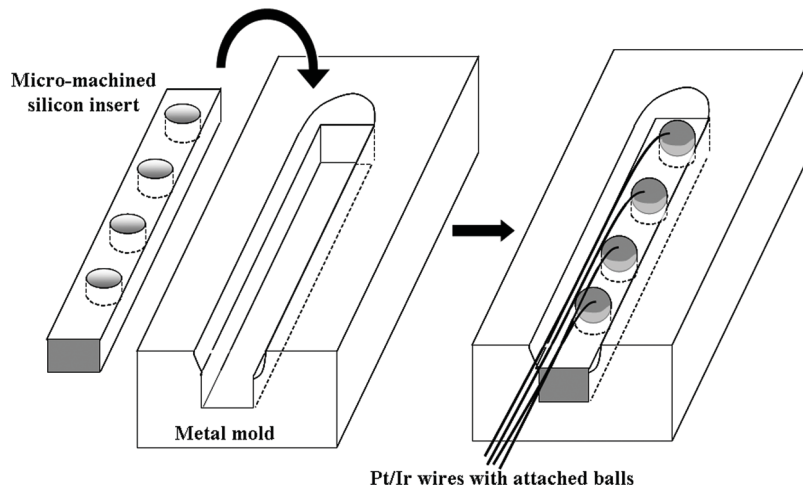

Fig. 6. Metal-silicon hybrid mold for the molding ball type intracochlear electrode array.

TABLE I
REACTIVITY GRADES FOR ELUTION TEST

Grade	Reactivity	Conditions of all cultures
0	None	Discrete intracytoplasmic granules; no cell lysis
1	Slight	Not more than 20% of the cells are round, loosely attached, and without intracytoplasmic granules; occasionally lysed cells are presents
2	Mild	Not more than 50% of the cells are round and devoid of intracytoplasmic granules; extensive cell lysis and empty areas between cells
3	Moderate	Not more than 70% of the cell layers contain rounded cells and/or lysed
4	Severe	Nearly complete destruction of the cell layers

Fetal Bovine Serum, Penicilli-Streptomycin and L-glutamine contained Minimum Essential Medium was used for the culturing media. The tests consisted of three groups; 1) the experimental group treated with eluate of the implantable unit; 2) the negative control group treated with high-density polyethylene (HDPE) ; 3) the positive control group treated with dimethyl sulfoxide (DMSO). After 24 h of treatment, cell reactivity grades were determined for each of the three groups based on the grading criteria described in Table I.

III. RESULTS

Preliminary testing has demonstrated that the system performs as designed. Fig. 7 shows a set of example waveforms at various points in the system. The top trace shows a speech input measured in an output node of the analog preprocessor and the bottom three traces show stimuli for three of the eight channels of processing and stimulation with $4.5 \text{ k}\Omega$ resistive loads connected between active electrode nodes and a reference electrode node, in place of the electrode array. The stimuli are well-

balanced biphasic pulses presented at the rate of 1000/s/electrode. The pulses are interleaved in time across electrodes so that pulses at any one electrode are not coincident with pulses for any other electrode, as specified by the CIS strategy [10]. This is illustrated further in the lower panel of Fig. 7, which shows with an expanded time scale the segment demarked in the upper panel with the dotted rectangle. The maximum charge unbalance of a stimulation pulse was measured to be approximately 180 pC , which was eliminated with the grounding of all electrodes between stimulation events.

Pulse amplitudes can range from $7.3 \mu\text{A}$ to 1.8 mA in $7.3\text{-}\mu\text{A}$ steps, and pulse duration can be set from $8.3 \mu\text{s}$ to $58.1 \mu\text{s}$ in $8.3\text{-}\mu\text{s}$ steps. Our telemetry circuit delivers digital data reliably with a coil-to-coil distance of up to 13 mm , with a transmission bit-error rate of better than 1×10^{-6} . The overall current dissipation of the entire system (including all external and internal components) is 105 mA . This corresponds to 17 h of continuous operation using an 1800 mAh lithium-ion rechargeable battery, which would allow a patient to use the device for a full day without recharging.

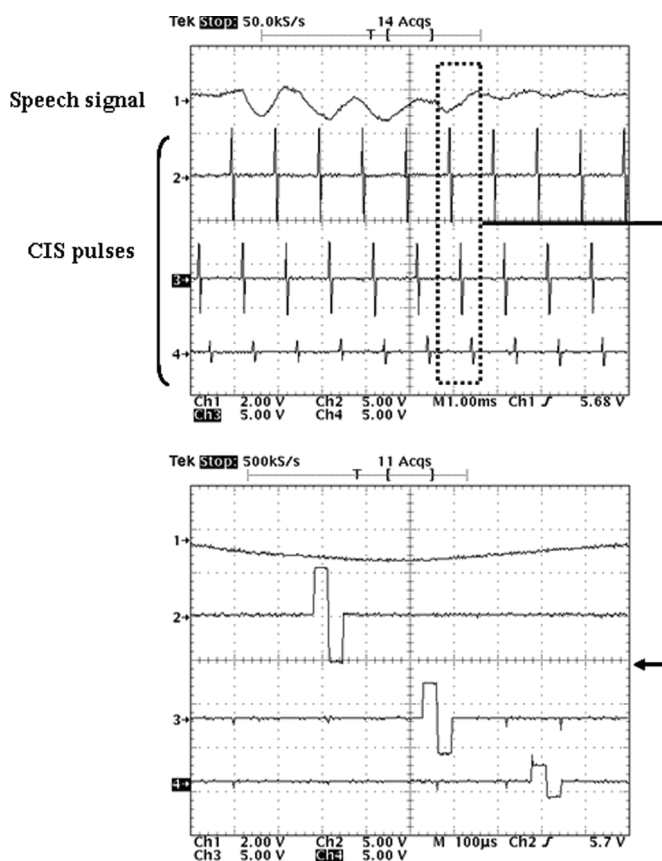

Fig. 7. Waveforms at various points in the system. Top trace in each panel shows a speech input measured at an output node of the analog preprocessor, and the bottom three traces in each panel show stimuli for the three of the eight channels of stimulation with $4.7\text{ k}\Omega$ resistors as loads. The lower panel shows the interlacing of stimulus pulses across channels using an expanded time scale. The segment shown is indicated by the dotted rectangle in the upper panel.

Photographs of the completed external and implanted components are shown in Fig. 8. The external speech processor has a size of $82\text{ mm} \times 49\text{ mm} \times 19\text{ mm}$ including the 1800 mAh rechargeable battery attached on the back [Fig. 8(a)]. The Ti metal package for the implanted receiver-stimulator is designed to be thin and to have a round shape, reducing the stress induced at the skin after implantation. An oval-shaped anchor with a coarse surface is also made on the bottom of the package for stable fixation and osseointegration to the skull.

The helium leak rate of the hermetically sealed part was tested using the methods described under MIL-STD-883E, Method 1014.10. The result of this test is shown in Fig. 9. Fig. 9 also illustrates micro-gaps surrounding the feedthrough in [Fig. 9, inset (a)], and the complete filling of these defects with the non-conductive crystallized SiO_2 layer in [Fig. 9, inset (b)]. The leak rate of the sol-treated part is less than 1×10^{-10} sccs (atm. cm^3/s). The resistance between adjacent feedthroughs exceeds several giga-ohms for all feedthroughs.

A straight array of intracochlear electrodes is shown in Fig. 10. Sixteen electrodes are used, allowing for up to 16 channels using monopolar stimulation (with reference to a remote electrode in the temporalis muscle or at some other distant site) or up to 8 channels of bipolar stimulation (between adjacent intracochlear electrodes). The present system is designed to

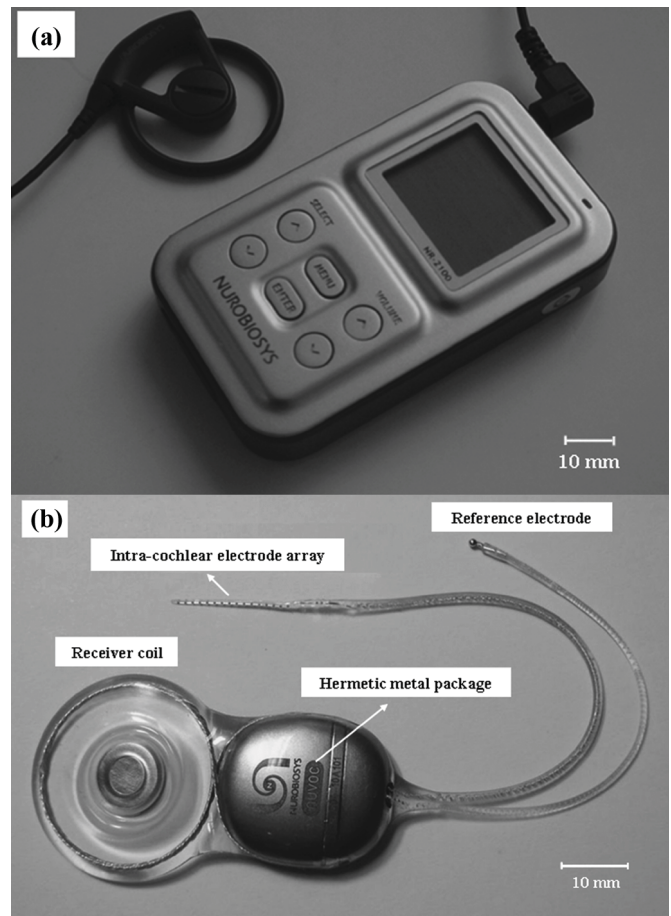

Fig. 8. Photographs of external (a) and implanted (b) components.

stimulate 8 of the 16 electrodes using the monopolar configuration, with one inactive electrode between each adjacent pair of active electrodes. The intracochlear segment of the electrode array inserted into the scala tympani (ST) of the cochlea is tapered from 0.5 mm at the most apical (distant) part to 0.7 mm at the basal part. The distance between adjacent electrode sites is 1.25 mm and the total length of the intracochlear segment is 24.5 mm, which is designed to be inserted 360° into the ST. As depicted in the inset of Fig. 10, the balls protrude about $130\ \mu\text{m}$ from the surface of the silicone carrier. The electrode array has an appropriate stiffness for insertion into the ST [23]. The impedance of the electrode-electrolyte interface was measured to be $3.70 \pm 0.39\text{ k}\Omega$ (in phosphate buffered saline, at 1 kHz). Preliminary results of a collaborative temporal bone study at the University of California, San Francisco, using previously developed methods [24], demonstrated that the electrode array was successfully implanted into the ST of human temporal bones. In this trial ($n = 6$) electrodes were inserted to a mean depth of 360° without significant trauma [25].

The result of the cytotoxicity tests of the implantable unit are presented in Table II. The positive control group showed moderate reaction of cells and the negative control group showed no reaction. The observed reactivity of the two control groups confirm that the cytotoxicity test was performed successfully. In the experimental group that was treated with eluate of the implantable unit, no significant cellular response was observed.

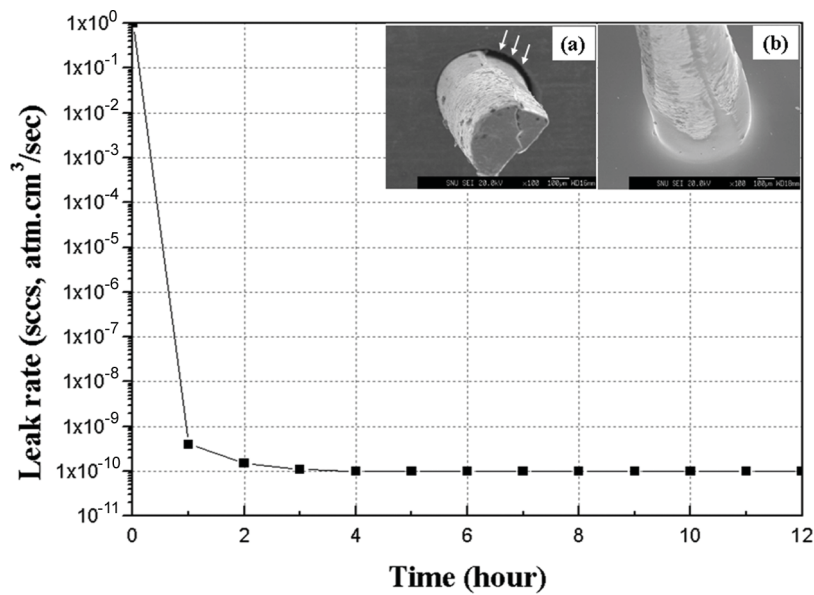

Fig. 9. Overall helium leak rate. Insets show micro gaps surrounding a feedthrough (a) and the filling of such gaps with the crystallized SiO₂ material (b).

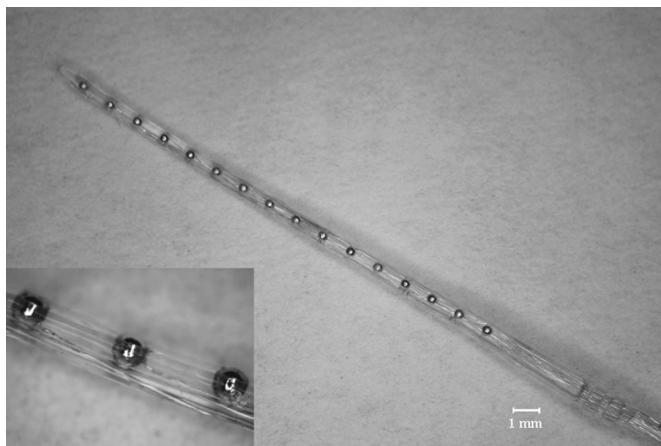

Fig. 10. Array of intracochlear electrodes. The electrodes are shaped as balls and protrude slightly from the surface of the silastic carrier, as illustrated in the inset.

TABLE II
RESULT OF CYTOTOXICITY SCORE TREATED WITH
EXTRACTION OF THE IMPLANTABLE UNIT

Group	Test item	Concentration (%(v/v), in media)	Cytotoxicity score
Negative control	Extract of HDPE	100.0	0
Positive control	DMSO	10.0	3
Experiment	Extract of the implant	6.1	0
		12.5	0
		25.0	0
		50.0	0
		100.0	0

IV. DISCUSSION

The system described in this report was developed in a university environment as an industrial collaboration program with a new startup company. It is also based on an international collaboration with critical assistance from experts in several areas of CI system design. There also have been expert advice and guidance from surgeons and audiologists. These experts donated their invaluable knowledge and time to the effort, with the hope and expectation that such a system will soon help profoundly hearing impaired people in developing countries who have been unable to benefit from CI technology due to its high cost. These were large contributing factors in reducing the cost of development.

We find that the receiver-stimulator chip, the electrode array, and the hermetic package are the three most critical components in the system. The design and manufacturing of these three components are key factors in determining the cost, performance, and reliability of the complete system. Therefore, to control the price and the quality, we developed each of these parts in house. With this approach, technological options can be selected that are simple and incurred lower manufacturing costs whenever these options do not affect performance or reliability.

In the communication between the receiver-stimulator chip and the speech processor, various options in encoding, modulation, and demodulation have been considered. PWM encoding, ASK demodulation, and pulse counting demodulation were selected based on simplicity and low power consumption. One of the advantages of the pulse counting demodulation is the increase in the allowable distance between the transmitting and receiving coils. When compared with the conventional envelope detection method, we observe up to a two-fold increase in the allowable coil-to-coil distance.

The hermetic package is a critical part that can limit the lifetime of the implant and is a principal contributor to its price. Sealing of the micro-gaps between the feedthroughs and the insulating ceramic plate is crucial. Conventionally, this is done

using a brazing method where the local application of filler metal is critical. The SiO₂ sol-gel used in our method is a viscous liquid and can be liberally dispensed in the area rather than being applied locally. This makes the process simple and low cost, while producing a truly outstanding seal.

The electrode array should have mechanical properties that minimize the probability of trauma during surgical insertion. In particular, it is crucial that the electrode array have appropriate stiffness [23], [25]. The temporal bone trials conducted with these electrodes indicate that a relatively soft array may reduce the incidence of trauma because the contact pressure between the electrode array and the cochlear inner wall is reduced [25]. On the other hand, sufficient stiffness is necessary to facilitate the surgical insertion of the array and to avoid kinking during this process. In general, the stiffness of electrode arrays for CIs is determined by metal wires because they have a Young's Modulus that is several thousands times higher than that of the silicone carrier [23]. Therefore, without a specific feature to increase stiffness of the apical electrode, the tip of the array will have very little inherent stiffness, as the number of wires in this location is minimal. To compensate for this, we used larger diameter wires (with a relatively high stiffness) for making a few apical stimulating contacts in the array, and thinner wires (with lower stiffness) for the basal stimulating contacts. In this way, an appropriate amount of stiffness is maintained throughout the length of the array. Results from an insertion study using human cadaver temporal bones demonstrated the full and nontraumatic insertion of our electrode array [25].

In order to verify the biological safety of the implantable unit, we performed the cytotoxicity testing with eluate of the implantable unit. The result showed that there was no reaction of cells, indicating that the material used in the implantable unit should be well tolerated *in vivo*.

Long-term implantation tests based on the ISO 10993-6 standard were also performed. Six implantable units were transplanted in New Zealand white rabbits. No inflammation, hemorrhage, necrosis, or discoloration in the implanted region of the subjects has been observed 90 days following implantation, and these results indicate the gross biocompatibility of the implantable unit.

Speech perception tests with human patients to verify the effectiveness of the system are in progress, with the cooperation of the Center for Auditory Prosthesis Research at the Research Triangle Institute (RTI) in the United States. The data from the tests now in progress will be presented in a separate publication.

ACKNOWLEDGMENT

This work was carried out based on academia-industry collaboration between the NBS-ERC of Seoul National University and the Nurobiosys Corporation. Electrode development was conducted in collaboration with the Epstein Laboratory at the University of California, San Francisco, with support from the National Institutes of Health (NIH) Contracts NO1-DC-2-1006 and Contract NO1-DC-3-1006. B. S. Wilson's time was supported in part by the RTI Fellow Program and the remaining time was donated by him. A team of medical experts also helped. Thoughtful comments and suggestions from Dr. C. S. Kim, Dr. S. O. Chang from Seoul National University Hospital,

Korea, and from Dr. K. S. Lee and S. H. Oh from Asan Medical Center, Seoul, Korea, and from Dr. J. T. McElveen, Jr., from the Carolina Ear and Hearing Clinic in Raleigh, NC, are all greatly appreciated. They would also like to thank W. H. Lim and Prof. N. S. Kim for their help with speech processor development. S. J. Kim would like to thank Dr. W. J. Heetderks of the United States National Institutes of Health for suggesting this project and for his encouragement throughout. Finally, the authors are grateful to the reviewers for their efforts to help us improve an initial version of this paper.

REFERENCES

- [1] B. S. Wilson, C. C. Finley, D. T. Lawson, R. D. Wolford, D. K. Eddington, and W. M. Rabinowitz, "Better speech recognition with cochlear implants," *Nature*, vol. 352, pp. 236–238, July 18, 1991.
- [2] D. K. Kessler, G. E. Loeb, and M. J. Barker, "Distribution of speech recognition results with the Clarion cochlear prosthesis," *Ann. Otol. Rhinol. Laryngol.*, vol. 104, no. Suppl. 166, pp. 283–285, Sept. 1995.
- [3] M. W. Skinner, G. M. Clark, L. A. Whitford, P. M. Seligman, S. J. Staller, D. B. Shipp, and J. K. Shallop *et al.*, "Evaluation of a new spectral peak coding strategy for the nucleus 22 channel cochlear implant system," *Am. J. Otol.*, vol. 15, no. Suppl. 2, pp. 15–27, 1994.
- [4] J. R. Wyatt, J. K. Niparko, M. L. Rothman, and G. V. DeLissovoy, "Cost-effectiveness of the multichannel cochlear implant," *Ann. Otol. Rhinol. Laryngol.*, vol. 104, no. Suppl. 166, pp. 248–250, Sept. 1995.
- [5] G. E. Loeb, R. V. Shannon, B. S. Wilson, F. G. Zeng, and S. Rebscher, "Design for an inexpensive but effective cochlear implant system; recommendations for an expert panel from the 1993 Zhengzhou International Symposium on Electrical Cochlear Hearing and Linguistics," in *Proc. Int. Cochlear Implant, Speech and Hearing Symp.*, Melbourne, Australia, Oct. 1994, pp. 24–28.
- [6] B. S. Wilson, S. Rebscher, F. G. Zeng, R. V. Shannon, G. E. Loeb, D. T. Lawson, and M. Zerbi, "Design for an inexpensive but effective cochlear implant," *Otolaryngol.—Head Neck Surg.*, vol. 118, no. 2, pp. 235–241, Feb. 1998.
- [7] B. S. Wilson, "New directions in implant design," in *Cochlear Implants*, S. B. Waltzman and N. L. Cohen, Eds. New York: Thieme Medical, 2000, pp. 43–56.
- [8] S. Brill, W. Gstättner, J. Helms, G. von Ilberg, W. Baumgartner, J. Müller, and J. Kiefer, "Optimization of channel number and stimulation rate for the fast continuous interleaved sampling strategy in the COMBI 40+," *Am. J. Otol.*, vol. 18, no. Suppl. 6, pp. S104–S106, 1997.
- [9] M. Dorman, P. Loizou, and D. Rainey, "Speech intelligibility as a function of the number of channels of stimulation for signal processor using sine-wave and noise-band outputs," *J. Acoust. Soc. Am.*, vol. 102, pp. 2403–2411, 1997.
- [10] B. S. Wilson, C. C. Finley, D. T. Lawson, R. D. Wolford, and M. Zerbi, "Design and evaluation of a continuous interleaved sampling (CIS) processing strategy for multichannel cochlear implants," *J Rehabil. Res. Dev.*, vol. 30, no. 1, pp. 110–116, 1993.
- [11] A. B. Hamida, M. Samet, N. Lakhrou, M. Drira, and J. Mouine, "Sound spectral processing based on fast Fourier transform applied to cochlear implant for the conception of a graphical spectrogram and for the generation of stimulating pulses," in *Proc. 24th Annu. Conf. IEEE Industrial Electronics Society*, 31 Aug.–4 Sept. 1998, vol. 3, pp. 1388–1393.
- [12] N. O. Sokal and A. D. Sokal, "Class E-A new class of high-efficiency tuned single-ended switching power amplifiers," *IEEE J. Solid-State Circuits*, vol. SC-10, no. 3, pp. 168–176, Jun. 1975.
- [13] Z. Hamici, R. Itti, and J. Champier, "A high-efficiency power and data transmission system for biomedical implanted electronic devices," *Meas. Sci. Technol.*, vol. 7, no. 2, pp. 192–201, 1996.
- [14] M. Kazimierzczuk, "Collector amplitude modulation of the Class E tuned power amplifier," *IEEE Trans. Circuits Syst.*, vol. 31, no. 6, pp. 543–549, Jun. 1984.
- [15] Z. Tang, B. Smith, J. H. Schild, and P. H. Peckham, "Data transmission from an implantable biotelemetry by load-shift keying using circuit configuration modulator," *IEEE Trans. Biomed. Eng.*, vol. 42, no. 5, pp. 524–528, May 1995.
- [16] J. H. Schild, "A multichannel implantable telemeter for acquisition of physiological data," masters thesis, Case Western Reserve Univ., Cleveland, OH, 1988.
- [17] B. C. Towe, "Passive biotelemetry by frequency keying," *IEEE Trans. Biomed. Eng.*, vol. BME-33, no. 10, pp. 905–909, 1986.

- [18] G. J. Suaning and N. H. Lovell, "CMOS neurostimulation ASIC with 100 channels, scaleable output and bidirectional radio-frequency telemetry," *IEEE Trans. Biomed. Eng.*, vol. 48, no. 2, pp. 248–260, Feb. 2001.
- [19] C. M. Zierhofer, I. J. Hochmair-Desoyer, and E. S. Hochmair, "Electronic design of a cochlear implant for multichannel high-rate pulsatile stimulation strategies," *IEEE Trans. Rehabil. Eng.*, vol. 3, no. 1, pp. 112–116, Mar. 1995.
- [20] S. I. Park, Y. S. Lim, and S. J. Kim, "An Implant Package for Prosthetic Cochleas and a Method for Manufacturing the Same," Korea patent, Filed no. 10-2004-0015298.
- [21] G. M. Clark and R. J. Hallworth, "A multiple-electrode array for a cochlear implant," *J. Laryngol Otol.*, vol. 90, no. 7, pp. 623–627, 1976.
- [22] R. A. Schindler, M. M. Merzenich, M. W. White, and B. Bjorkroth, "Multielectrode intracochlear implants," *Arch. Otolaryngol.*, vol. 103, no. 12, pp. 691–699, Dec. 1977.
- [23] Y. S. Lim, S. I. Park, Y. H. Kim, S. H. Oh, and S. J. Kim, "Three-dimensional analysis of electrode behavior in a human cochlear model," *Med. Eng. Phys.*, vol. 27, no. 8, pp. 695–703, Oct. 2005.
- [24] P. Wardrop, D. Whinney, S. J. Rebscher, J. T. Roland, Jr., W. Luxford, and P. A. Leake, "A temporal bone study of insertion trauma and intracochlear position of cochlear implant electrodes. I: Comparison of nucleus banded and nucleus contour™ electrodes," *Hear. Res.*, vol. 203, pp. 54–67, May 2005.
- [25] S. J. Rebscher, P. J. Wardrop, A. Karkanevatos, L. Lustig, J. Ali, B. Bonham, R. Snyder, and P. A. Leak, "Future development of cochlear implant electrodes," presented at the 2005 Conf. Implantable Auditory Prostheses, Pacific Grove, CA.



Soon Kwan An received B.S. and M.S. degrees in electrical engineering from Seoul National University (SNU), Seoul, Korea, in 1999 and 2001, respectively. His M.S. degree thesis was on fabrication of a silicon-based microelectrode array with monolithically integrated CMOS source followers. Since March 2001, he has been working toward the Ph.D. degree in the School of Electrical and Computer Engineering, Seoul National University.

Since November 2006, he has also been a Manager of the Chip and System Development Team at Neurobiosys Corporation, Seoul. His research interests are in areas of bioelectronics, bioinstrumentation, and neural prosthesis.



Se-Ik Park received the Ph.D. degree in electrical engineering and computer sciences from Seoul National University (SNU), Seoul, Korea, in 2006. His Ph.D. degree thesis was on the development of next-generation deep brain stimulation (DBS) system and its applications.

Since 2002, he has been working for Neurobiosys Corporation, Seoul, as a Director and Manager of the R&D team, where the major research activities are the development of cochlear implantation and deep brain stimulation systems. He is also a postdoctoral research fellow of Nano Bioelectronics and System Research Center (NBS-ERC), funded by Korea Science and Engineering Foundation (KOSEF). His research interests are in the areas of biosensors and neural prosthesis, especially on stimulating electrode and hermetic biopackage.

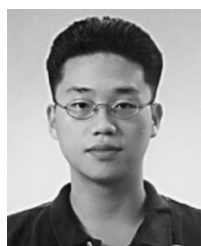

Sang Beom Jun received B.S. and M.S. degrees in electrical engineering from Seoul National University (SNU), Seoul, Korea, in 1999 and 2001, respectively. He received the Ph.D. degree in electrical engineering and computer science from SNU in 2007. His Ph.D. degree thesis was on formation and characterization of low-density neural networks on microelectrode arrays.

His research has focused on analysis and patterning of neural networks cultured on microelectrode arrays. He is also working for the development of a cochlear implant system for human application, especially in the development of intracochlear electrodes and hermetic packages.



Choong Jae Lee received the B.S. degree from the School of Electrical and Computer Engineering, Seoul National University, Seoul, Korea, in 2001. Since March 2001, he has been working toward the Ph.D. degree at the School of Electrical and Computer Engineering, Seoul National University.

His research interests include bidirectional biotelemetry and receiver stimulator circuit on their application to neural prosthesis device. He is also interested in safe and effective stimulation system.

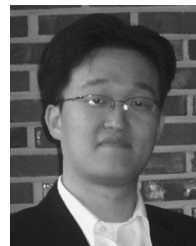

Kyung Min Byun received the B.S. and M.S. degrees in electrical engineering at Seoul National University, Seoul, Korea. He received the Ph.D. degree at the same university in 2007.

He currently works on surface plasmon resonance (SPR) biosensors based on nanostructures. His current interests include the theoretical and experimental study of extremely sensitive SPR biosensors and the implementation and characterization of nanowire-mediated SPR structures.

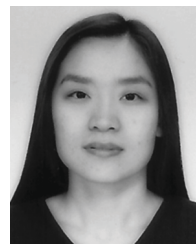

Jung Hyun Sung received the M.S. degree in chemistry engineering from Soongsil University, Seoul, Korea, in 1999. Her masters thesis was on the Desulfurization of PBT by using Gordona sp.

From 1999–2002, she was a Researcher with the Samsung Biomedical Research Institute, Suwon, Korea. From 2005–2006, she was with Neurobiosys Corporation, Seoul, as a staff member of the Electrode Development team. She is currently a Manager of Quality Management System and Regulatory Affairs with BioSpine Co., Ltd., Seoul. Her research

interests are in the areas of medical device for semi-rigid and dynamic stabilization in the treatment of back pain and leg pain.



Blake S. Wilson (M'80–SM'06) is a Senior Fellow at RTI International, Research Triangle Park, NC, and an Adjunct Professor at the Duke University Medical Center, Durham, NC. He is the inventor of most of the speech processing strategies used with present-day cochlear implants, including the continuous interleaved sampling (CIS), spectral peak picking (e.g., "n-of-m"), and virtual channel strategies, among others. The CIS and n-of-m strategies, or direct descendants of them, are used as the default strategies for all three implant systems now

in widespread use. One of his papers, in the *Nature*, alternates with one other paper as the most highly cited publication in the field of cochlear implants. He has served as the Principal Investigator for 24 projects, including 13 projects for the National Institutes of Health (NIH).

Dr. Wilson and his coworkers have been recognized by many awards and honors, most notably the 1996 Discover Award for Technological Innovation and the American Otological Society's President's Citation for "Major contributions to the restoration of hearing in profoundly deaf persons." He has been the Guest of Honor at 10 international conferences, and has been a keynote or invited speaker at more than 130 others. He has served as the Chair for two large international conferences and as the Co-Chair for two others. Most recently, he was selected to receive the 2007 Distinguished Alumnus Award from the Pratt School of Engineering at Duke.



Stephen J. Rebscher received the B.S. and M.A. degrees in biological sciences from San Jose State University, San Jose, CA, in 1976 and 1979. His thesis work was in invertebrate zoology with a concentration in electron microscopy.

He has been a Research Specialist with the Department of Otolaryngology, the University of California at San Francisco (UCSF) since 1979 when he began work on cochlear implant safety and design issues. He was a co-inventor of the UCSF/Storz and UCSF/Advanced Bionics clinical cochlear im-

plant systems and participated in the clinical trials of these devices. He was an invited speaker at the Zhengzhou International Symposium on Cochlear Implants and Linguistics, Zhengzhou, China, in 1993 and co-author of several publications describing possible cochlear implant design strategies applicable to economically challenged regions. His current research interests include assessment of damage associated with cochlear implantation, histopathological and neurophysiological effects of long-term electrical stimulation of the auditory system and the development of more effective stimulating electrodes for use in cochlear implants.



Seung Ha Oh received the M.D. degree from the Seoul National University College of Medicine, Seoul, Korea, in 1985. He received M.S. and Ph.D. degrees in Microbiology at the same college in 1993 and 1997, respectively. His Ph.D. degree thesis was the expression pattern and its role of BMP-4 and BMP-7 during inner ear development of chicken. He received the M.D. degree from the Seoul National University College of Medicine, Seoul, Korea, in 1985.

He received resident training at the Department of Otolaryngology, Seoul National University Hospital, from 1989 to 1992. After completing the board examination of Otolaryngology he worked at the same hospital as an Otology Clinical Fellow from 1992 to 1994. He was a Research Fellow at NIDCD, NIH from 1994 to 1996, studying the developmental biology of inner ear under the mentorship of Dr. D. Lim and Dr. D. Wu. In 1996, he re-

turned to Korea to join the Department of Otolaryngology, Seoul National University College of Medicine, as a Clinical Instructor, where he is now an Associate Professor. From 1999 to 2001, he was a Visiting Scholar at the Department of Otolaryngology, University of Michigan, Ann Arbor, MI, where he studied the damage and protection related molecules in the inner ear of mice. He is a clinical specialist of Otology and Neuro-otology and especially interested in the cochlear implant and its related science. His research interests are in the areas of damage and protection mechanism of the inner ear as well as the brain plasticity following cochlear implantation. He has managed several research projects and published more than 40 papers.



Sung June Kim (S'79–M'84–SM'06) received the B.S. degree in electronics engineering from Seoul National University (SNU), Seoul, Korea, in 1978. He received M.S. and Ph.D. degrees in electrical engineering from Cornell University, Ithaca, NY, in 1981, and 1983, respectively. His Ph.D. degree thesis was on the photo-induced fabrication of trans-substrate microelectrode arrays based on silicon substrate as neural interface.

From 1983 to 1989, he worked as an MTS with Bell Laboratories, Murray Hill, NJ. At Bell Labs, he studied design and processing of silicon VLSI, and the process and device development of optoelectronic integrated circuits. In 1989, he returned to Korea to join SNU, where he is now a Full Professor in the School of Electrical Engineering. Since 2000, he has served as director of the Nano-Bioelectronics and System Research Center (NBS) at SNU, which is an ERC funded by the Korean Science and Engineering Foundation. At NBS, he works on implantable neural prostheses, and cell/protein chips, together with 20 other faculty members with diverse engineering and medical backgrounds. In 2001, he co-founded Nurobiosys Corporation, Seoul, for manufacturing of neural prosthetic devices. With Nurobiosys, he hopes to achieve lower cost devices of cochlear implant and deep brain stimulator to benefit more people with disabilities. He has published about 70 journal papers in the areas of bioelectronics, biosensors, optoelectronics, and semiconductor fabrication.

Interfacing Sensors With the Nervous System: Lessons From the Development and Success of the Cochlear Implant

Blake S. Wilson, *Senior Member, IEEE*, and Michael F. Dorman

Invited Paper

Abstract—The cochlear implant is the most successful neural prosthesis to date and may serve as a paradigm for the development or further development of other systems to interface sensors with the nervous system, e.g., visual or vestibular prostheses. This paper traces the history of cochlear implants and describes how the current levels of performance have been achieved. Lessons and insights from this experience are presented in concluding sections.

Index Terms—Auditory prosthesis, cochlear implant, deafness, hearing, nervous system, neural prosthesis, sensors, speech perception, vestibular prosthesis, visual prosthesis.

I. INTRODUCTION

THE COCHLEAR implant is one of the great success stories of modern medicine. Just 30 years ago, cochlear implants provided little more than a sensation of sound and sound cadences. They were useful as an aid to lipreading. Now, a majority of implant users enjoy high levels of speech recognition using hearing alone; indeed, many can use the telephone without difficulty. This is a long trip in a short time, and the restoration of function—from total or nearly total deafness to useful hearing—is truly remarkable.

In this paper, we trace this history and indicate how the present levels of performance have been achieved. The design of cochlear implants is described in some detail to provide an example of ways in which sensors can be successfully interfaced to the nervous system. Results from studies with implant patients are presented. In addition, we describe some of the limitations of present systems and possibilities for overcoming them. We conclude with a section on the lessons learned from cochlear implants and how those lessons might inform the designs of other types of sensory neural prostheses, such as prostheses for the restoration of vision or balance.

Manuscript received July 10, 2007; revised September 11, 2007; accepted September 20, 2007. This work was supported in part by NIH Project N01-DC-2-1002 (BSW) and Project 5R01DC000654 (MFD). This paper was presented in part at an invited lecture by author B. S. Wilson at the NIH-sponsored 2004 Neural Interfaces Workshop, Bethesda, MD, and with the title “The auditory prosthesis as a paradigm for successful neural interfaces.” The associate editor coordinating the review of this paper and approving it for publication was Dr. Robert Black.

B. S. Wilson is with the Department of Surgery, Duke University Medical Center, Durham, NC 27710 USA (e-mail: blake.wilson@duke.edu).

M. F. Dorman is with the Department of Speech and Hearing Science, Arizona State University, Tempe, AZ 85287-0102 USA (e-mail: mdorman@asu.edu).

Color versions of one or more of the figures in this paper are available online at <http://ieeexplore.ieee.org>.

Digital Object Identifier 10.1109/JSEN.2007.912917

II. A BRIEF HISTORY

As recently as the early 1980s, many eminent and highly knowledgeable people believed that cochlear implants would provide only an awareness of environmental sounds and possibly speech cadences to their users. Many were skeptical of implants and thought that mimicking or reinstating the function of the exquisite machinery in the normal inner ear was a fool’s dream. Among these critics were world-renowned experts in otology and auditory physiology. Fortunately, pioneers persisted in the face of this intense criticism and provided the foundations for present devices. Detailed reviews of the early history of cochlear implants are presented in [1]–[3].

A timeline of assessments in the development of cochlear implants is presented in Table I. These range from frank skepticism at the beginning to high enthusiasm by 1995.

The first implant of a device for electrical stimulation of the auditory nerve was performed by Djourno and Eyriès in Paris in 1957. An induction coil was used, with one end placed on the stump of the auditory nerve or adjacent brainstem and the other end within the temporalis muscle (the patient had had bilateral cholesteatomas which had been removed in prior operations, taking the cochleas and peripheral parts of the auditory nerves with them). The patient used the device for several months before it failed, and was able to sense the presence of environmental sounds but could not understand speech or discriminate among speakers or many sounds. In 1961, Dr. William F. House implanted two patients in Los Angeles, each with single gold wires inserted a short distance into the (deaf) cochlea. By 1975, more patients had been implanted worldwide, most by Dr. House, and 13 had functioning, single-channel devices. The United States National Institutes of Health (NIH) commissioned a study at that point, to assess the performance of those devices and to determine whether support by the NIH for the further development of cochlear implants would be wise. The report from the study [4], the “Bilger report,” is a landmark in the field. Its key conclusion was that “although the subjects could not understand speech through their prostheses, they did score significantly higher on tests of lipreading and recognition of environmental sounds with their prostheses activated than without them.” This and earlier assessments are included in Table I.

Shortly after the Bilger report was published, the NIH did elect to support research and development efforts in the field. The rapid progress thereafter in the design and performance of implant systems was in very large part the direct result of this

TABLE I
A LINE OF PROGRESS

Person or Event	Year	Comment or Outcome
Merle Lawrence	1964	“Direct stimulation of the auditory nerve fibers with resultant perception of speech is not feasible.”
Blair Simmons	1966	Rated the chances that electrical stimulation of the auditory nerve might ever provide “uniquely useful communication” at about 5 percent.
Harold Schuknecht	1974	“I have the utmost admiration for the courage of those surgeons who have implanted humans, and I will admit that we need a new operation in otology, but I am afraid this is not it.”
Bilger report	1977	“Although the subjects could not understand speech through their prostheses, they did score significantly higher on tests of lipreading and recognition of environmental sounds with their prostheses activated than without them.” (This was a NIH-funded study of the world’s population of implant patients at the time, all 13 of them!)
First NIH Consensus Statement	1988	Suggested that multichannel implants were more likely to be effective than single-channel implants, and indicated that about 1 in 20 patients could carry out a normal conversation without lipreading. (The world population of implant recipients was about 3,000 in 1988.)
Second NIH Consensus Statement	1995	“A majority of those individuals with the latest speech processors for their implants will score above 80 percent correct on high-context sentences, even without visual cues.” (The number of implant recipients approximated 12,000 in 1995 and is more than 110,000 now.)

decision. In particular, work supported through the Neural Prosthesis Program at the NIH, first directed by Dr. F. Terry Hambrecht and later by Dr. William J. Heetderks, produced many important innovations in electrode and speech processor designs that remain in use to this day.

In 1988, the NIH convened the first of two consensus development conferences on cochlear implants. Multichannel systems—with multiple channels of processing and with multiple sites of stimulation in the cochlea—had come into use at that time. The consensus statement from the 1988 conference [5] suggested that multichannel implants were more likely to be effective than single-channel implants, and indicated that about 1 in 20 patients could carry out a normal conversation without lipreading. Approximately 3000 patients had received cochlear implants by 1988.

New and highly effective processing strategies for cochlear implants were developed in the late 1980s and early 1990s, principally through the Neural Prosthesis Program. Among these were the continuous interleaved sampling (CIS) [6], *n-of-m* [7], and spectral peak (SPEAK) [8] strategies. Large gains in speech reception performance were achieved with these strategies, two of which remain in widespread use today (CIS and *n-of-m*). A detailed review of processing strategies and their lines of development is presented in [9].

The second NIH consensus development conference was held in 1995. By then, approximately 12 000 patients had received implants. A major conclusion from the 1995 conference [10] was that “a majority of those individuals with the latest speech processors for their implants will score above 80% correct on high-context sentences even without visual cues.”

By the middle of 2006, the cumulative number of implants worldwide exceeded 110 000. This number is orders of magnitude higher than the numbers for all other types of neural prostheses, including those for restoration of motor or other sensory functions.

Fig. 1 shows the number of cochlear implants over time, beginning in 1957 with the first implant operation by Djourno and Eyriès. The growth in numbers since then is exponential.

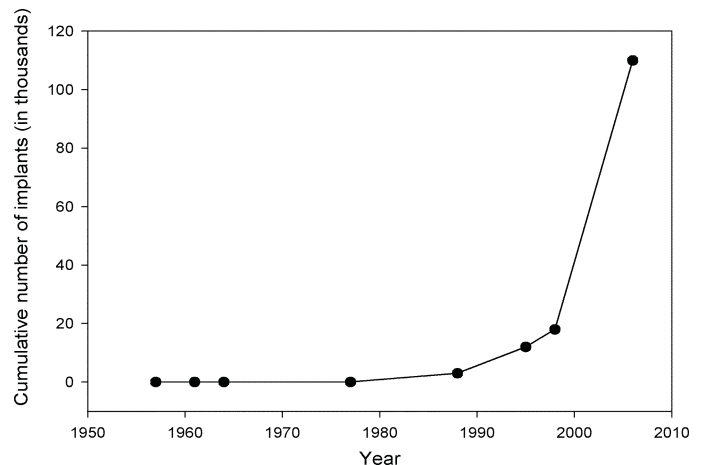

Fig. 1. Cumulative number of implants across years. Events marked by the dots include: 1) the first implant operation by Dr. Andre Djourno and Dr. Charles Eyriès in 1957; 2) the first two implants by Dr. William F. House in 1961; 3) the first implant by Dr. F. Blair Simmons in 1964; 4) the “Bilger Report” in 1977; 5) the first NIH Consensus Conference on Cochlear Implants in 1988; 6) the second NIH Consensus Conference in 1995; 7) the National Academy of Sciences report [2] in 1998; and 8) the middle of 2006. Multichannel devices began to supplant single-channel devices in the early 1980s, and highly effective processing strategies were introduced into widespread clinical use in the early 1990s, as described in the text. These large steps forward fueled the increasing acceptance and applications of cochlear implants.

III. DESIGN OF COCHLEAR IMPLANTS

A. Aspects of Normal Hearing

In normal hearing, sound waves traveling through air reach the tympanic membrane via the ear canal, causing vibrations that move the three small bones of the middle ear. This action produces a piston-like movement of the stapes, the third bone in the chain. The “footplate” of the stapes is attached to a flexible membrane in the bony shell of the cochlea called the oval window. Inward and outward movements of this membrane induce pressure oscillations in the cochlear fluids, which in turn initiate a traveling wave of displacement along the basilar membrane

(BM), a highly specialized structure that divides the cochlea along its length. This membrane has graded mechanical properties. At the base of the cochlea, near the stapes and oval window, it is narrow and stiff. At the other end of the cochlea, near the apex, the membrane is wide and flexible. These properties give rise to the traveling wave and to points of maximal response according to the frequency or frequencies of the pressure oscillations in the cochlear fluids. The traveling wave propagates from the base to the apex. For an oscillation with a single frequency, the magnitude of displacements increases up to a particular point along the membrane and then drops precipitously thereafter. High frequencies produce maxima near the base of the cochlea, whereas low frequencies produce maxima near the apex.

Motion of the BM is sensed by the inner hair cells (IHCs) in the cochlea, which are attached to the top of the BM in a matrix of cells called the organ of Corti. Each hair cell has fine rods of protein, called stereocilia, emerging from one end. When the BM moves at the location of a hair cell, the rods are deflected as if hinged at their bases. Such deflections in one direction increase the release of chemical transmitter substance at the base (other end) of the cells, and deflections in the other direction inhibit the release. The variations in the concentration of the chemical transmitter substance act at the terminal ends of auditory neurons, which are immediately adjacent to the bases of the IHCs. Increases in chemical transmitter substance increase discharge activity in the nearby neurons, whereas decrements in the substance inhibit activity. Changes in neural activity thus reflect events at the BM. These changes are transmitted to the brain via the auditory nerve, the collection of all neurons that innervate the cochlea.

The steps described above are illustrated in the top panel of Fig. 2. This shows a cartoon of the main anatomical structures, including the tympanic membrane (the curved line in the left part of the middle ear diagram), the three bones of the middle ear, the oval window (between the middle and inner ears and immediately adjacent to the stirrup-shaped stapes bone in the middle ear), the BM, the IHCs, and the adjacent neurons of the auditory nerve (which span the dashed line between the inner ear and the central nervous system).

B. Loss of Hearing

The principal cause of hearing loss is damage to or complete destruction of the sensory hair cells. Unfortunately, the hair cells are fragile structures and are subject to a wide variety of insults, including but not limited to genetic defects, infectious diseases (e.g., rubella and meningitis), overexposure to loud sounds, certain drugs (e.g., kanamycin, streptomycin, and cisplatin), and aging. In the deaf or deafened cochlea, the hair cells are largely or completely absent, severing the connection between the peripheral and central auditory systems. The function of a cochlear prosthesis is to bypass the (missing) hair cells by stimulating directly the surviving neurons in the auditory nerve.

The anatomical situation faced by designers of cochlear implants is illustrated in the bottom panel of Fig. 2. The panel shows a complete absence of hair cells. In general, a small number of cells may remain for some patients, usually in the apical (low frequency) part of the cochlea.

Without the normal stimulation provided by the hair cells, the peripheral part of the neurons—between the cell bodies in the

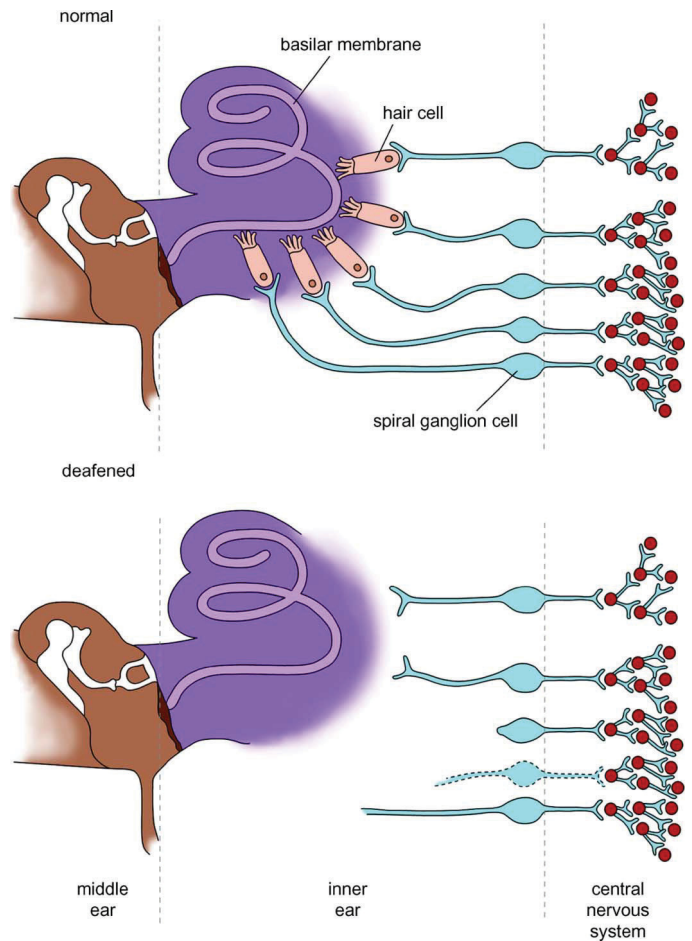

Fig. 2. Illustrations of anatomical structures in the normal and deafened ears. Note the absence of sensory hair cells in the deafened ear. Also note the incomplete survival of spiral ganglion cells and of neural processes peripheral to cells that are still viable. For simplicity, the illustrations do not reflect the details of the structures or use a consistent scale for the different structures. (Figure is from [57] and is used here with the permission of the American Scientist and Sigma Xi.) (A color version of this figure is available online at <http://ieeexplore.ieee.org>.)

spiral ganglion and the terminals within the organ of Corti—undergo “retrograde degeneration” and eventually die [11]. Fortunately, the cell bodies are far more robust. At least some usually survive, even for prolonged deafness or for virulent etiologies such as meningitis [11]–[13]. These cells, or more specifically the nodes of Ranvier just distal or proximal to them, are the putative sites of excitation for cochlear implants.

C. Electrical Stimulation of the Auditory Nerve

Direct stimulation of the nerve is produced by currents delivered through electrodes placed in the scala tympani (ST), one of three fluid-filled chambers along the length of the cochlea. (The boundary between the ST and the scala media is formed by the BM and organ of Corti.) A cutaway drawing of the implanted cochlea is presented in Fig. 3. The figure shows a partial insertion of an array of electrodes into the ST. The array is inserted through a drilled opening made by the surgeon in the bony shell of the cochlea overlying the ST (called a “cochleostomy”) and close to the base of the cochlea. Alternatively, the array may be inserted through the second flexible membrane of the cochlea,

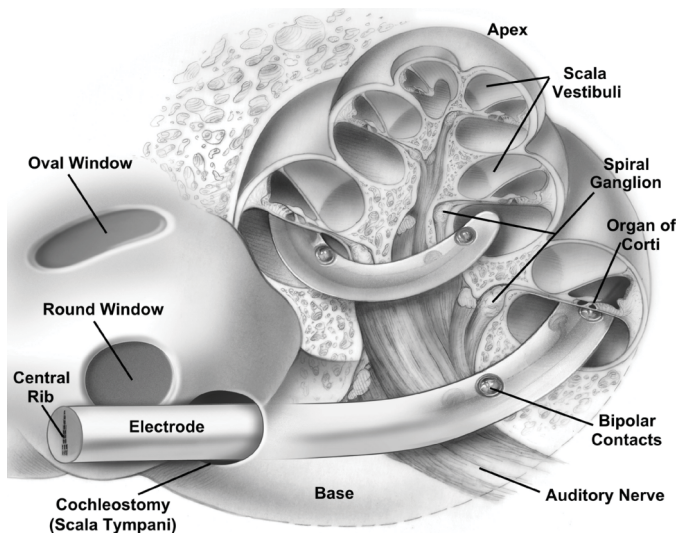

Fig. 3. Cutaway drawing of the implanted cochlea. The electrode array (labeled “Electrode”) developed at the University of California at San Francisco is illustrated [138]. That array includes eight pairs of bipolar electrodes (or “Contacts”), spaced at 2 mm intervals and with the electrodes in each pair oriented in an “offset radial” arrangement with respect to the neural processes peripheral to the ganglion cells in the intact cochlea. Only four of the bipolar pairs are visible in the drawing, as the others are “hidden” by cochlear structures. This array was used in the UCSF/Storz and Clarion® 1.0 devices. (Figure is from [13] and is used here with the permission of Springer-Verlag.).

the round window membrane, which also is close to the basal end of the cochlea and ST (see drawing).

The depth of insertion is limited by the decreasing lumen of the ST from base to apex, the curvature of the cochlear spiral, and an uneven and unsmooth lumen particularly in the apical region. No array has been inserted farther than about 30 mm, and typical insertions are much less than that, e.g., 18–26 mm. (The total length of the typical human cochlea is about 35 mm.) In some cases, only shallow insertions are possible, such as when bony obstructions in the lumen impede further insertion.

Different electrodes in the implanted array may stimulate different subpopulations of neurons. As described above, neurons at different positions along the length of the cochlea respond to different frequencies of acoustic stimulation in normal hearing. Implant systems attempt to mimic or reproduce this “tonotopic” encoding by stimulating basally situated electrodes (first turn of the cochlea and lower part of the drawing) to indicate the presence of high-frequency sounds, and by stimulating electrodes at more apical positions (deeper into the ST and ascending along the first and second turns in the drawing) to indicate the presence of sounds with lower frequencies. Closely spaced pairs of bipolar electrodes are illustrated here, but arrays of single electrodes that are each referenced to a remote electrode outside the cochlea also may be used. This latter arrangement is called a “monopolar coupling configuration” and is used in all present-day implant systems that are widely applied worldwide. (There are three such systems and they constitute more than 99% of the cochlear implant market.)

The spatial specificity of stimulation with a ST electrode most likely depends on a variety of factors, including the orientation and geometric arrangement of the electrodes, the proximity of the electrodes to the target neural structures, and the condition

of the implanted cochlea in terms of nerve survival and ossification. An important goal of electrode design is to maximize the number of largely nonoverlapping populations of neurons that can be addressed with the electrode array. Present evidence suggests, however, that no more than 4–8 independent sites may be available using current designs, even for arrays with as many as 22 electrodes [14]–[19]. Most likely, the number of independent sites is limited by substantial overlaps in the electric fields from adjacent (and more distant) electrodes. The overlaps are unavoidable for electrode placements in the ST, as the electrodes are sitting in the highly conductive fluid of the perilymph and additionally are relatively far away from the target neural tissue in the spiral ganglion. A closer apposition of the electrodes next to the inner wall of the ST would move them a bit closer to the target cells (see Fig. 3), and such placements have been shown in some cases to produce an improvement in the spatial specificity of stimulation [20]. However, a large gain in the number of independent sites may well require a fundamentally new type of electrode, or a fundamentally different placement of electrodes. The many issues related to electrode design, along with prospects for the future, are discussed in [20]–[30].

Fig. 3 shows a complete presence of hair cells (in the labeled organ of Corti) and a pristine survival of cochlear neurons. However, the number of hair cells is zero or close to it in cases of total deafness. In addition, survival of neural processes peripheral to the ganglion cells (the “dendrites”) is rare in the deafened cochlea, as noted before. Survival of the ganglion cells and central processes (the axons) ranges from sparse to substantial. The pattern of survival is in general not uniform, with reduced or sharply reduced counts of cells in certain regions of the cochlea. In all, the neural substrate or target for a cochlear implant can be quite different from one patient to the next. A detailed review of these observations and issues is presented in [13].

D. Components of Cochlear Implant Systems

The essential components in a cochlear prosthesis include: 1) a microphone for sensing sound in the environment; 2) a speech processor to transform the microphone input into a set of stimuli for the implanted array of electrodes; 3) a transcutaneous link for the transmission of power and stimulus information across the skin; 4) an implanted receiver/stimulator to decode the information received from the radio-frequency signal produced by an external coil and then to generate stimuli using the instructions obtained from the decoded information; 5) a cable to connect the outputs of the receiver/stimulator to the electrodes; and 6) the array of electrodes. These components must work together as a system to support excellent performance and a weakness in a component can degrade performance significantly. For example, a limitation in the data bandwidth of the transcutaneous link can restrict the types and rates of stimuli that can be specified by the external speech processor and this, in turn, can limit performance. A thorough discussion of considerations for the design of cochlear prostheses and their constituent parts is presented in [27].

We note that an earlier implant system, the Ineraid® device, had a percutaneous connector rather than a transcutaneous link. In addition, several experimental implant systems included percutaneous connectors. Although use of these through-the-skin

connectors increased the risk of infection, they also provided direct electrical access to the implanted electrodes from an external speech processor or other stimulating or recording equipment. This access allowed full stimulus control and high-fidelity recordings of intracochlear evoked potentials. A wide variety of speech processing strategies was evaluated with subjects having percutaneous connectors. This was vital for the development of strategies now in widespread use and for the acquisition of knowledge about the stimulus-response properties of the electrically stimulated auditory nerve in humans.

E. Transformation of a Microphone Input Into Stimuli for the Implant

An important aspect of the design for any type of sensory neural prosthesis is how to transform an input from a sensor or array of sensors into a set of stimuli that can be interpreted by the nervous system. The stimuli can be electrical or tactile, for examples, and usually involve multiple sites of stimulation, corresponding to the spatial mapping of inputs and representations of those inputs in the nervous system. One approach to the transformation—and probably the most effective approach—is to mimic or replicate at least to some extent the damaged or missing physiological functions that are bypassed or replaced by the prosthesis.

Of course, limitations in other parts of the prosthesis system may restrict what can be done with the transformation. Effects of limitations in the bandwidth of the transcutaneous link for cochlear implant systems have been mentioned. Also, a lack of independence among stimulus sites can greatly reduce the number of channels of information that can be conveyed to the nervous system. In such cases, a high number of channels in processing the input(s) from the sensor(s) would not in general produce any benefit and might even degrade performance.

For cochlear implants, this part of the design is called the processing strategy. As noted previously, advances in processing strategies have produced quite large improvements in the speech reception performance of implant patients, from recognition of a tiny percentage of monosyllabic words with the first strategies and multisite stimulation, for example, to recognition of a high percentage of the words with current strategies and multisite stimulation.

One of the simpler approaches supporting the recent levels of performance with implants is illustrated in Fig. 4. This is the CIS strategy, which is used as the default strategy or as a processing option in all implant systems now in widespread clinical use.

The CIS strategy filters speech or other input sounds into bands of frequencies with a bank of bandpass filters. Envelope variations in the different bands are represented at corresponding electrodes in the cochlea with modulated trains of biphasic electrical pulses. The envelope signals extracted from the bandpass filters are compressed with a nonlinear mapping function prior to the modulation, in order to map the wide dynamic range of sound in the environment (around 90 dB) into the narrow dynamic range of electrically evoked hearing (about 10 dB or somewhat higher). The output of each bandpass channel is directed to a single electrode, with low-to-high channels assigned to apical-to-basal electrodes, to mimic at least the order, if not the precise locations, of frequency mapping in

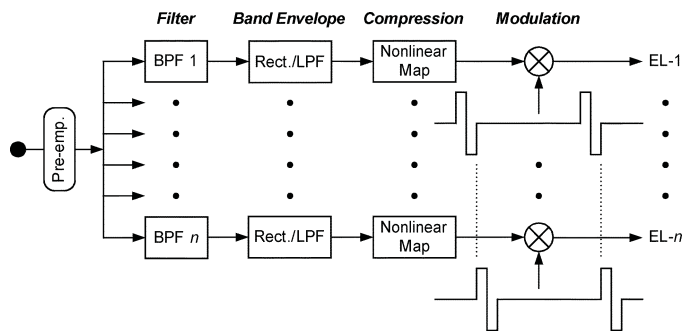

Fig. 4. Block diagram of the CIS strategy. The strategy uses a pre-emphasis filter (Pre-emp.) to attenuate strong components in speech below 1.2 kHz. The pre-emphasis filter is followed by multiple channels of processing. Each channel includes stages of bandpass filtering (BPF), envelope detection, compression, and modulation. The envelope detectors generally use a full-wave or half-wave rectifier (Rect.) followed by a low-pass filter (LPF). A Hilbert Transform or a half-wave rectifier without the low-pass filter also may be used. Carrier waveforms for two of the modulators are shown immediately below the two corresponding multiplier blocks (circles with a “x” mark within them). The outputs of the multipliers are directed to intracochlear electrodes (EL-1 to EL- n), via a transcutaneous link or a percutaneous connector. (Diagram adapted from [6] and used here with the permission of the Nature Publishing Group.)

the normal cochlea. The pulse trains for the different channels and corresponding electrodes are interleaved in time, so that the pulses across channels and electrodes are nonsimultaneous. This eliminates a principal component of electrode interaction, which otherwise would be produced by direct vector summation of the electric fields from different (simultaneously stimulated) electrodes. The corner frequency of the low-pass filter in each envelope detector typically is set at 200 Hz or higher, so that the fundamental frequencies of speech sounds are represented in the modulation waveforms. CIS gets its name from the continuous sampling of the (compressed) envelope signals by rapidly presented pulses that are interleaved across electrodes. Between 4 and 22 channels (and corresponding stimulus sites) have been used in CIS implementations to date.

Other strategies also have produced excellent results. Among these are the n -of- m strategy mentioned above, and the advanced combination encoder (ACE) strategy [31], which is similar in design and performance to the n -of- m strategy [9]. The principal difference between CIS and the n -of- m or ACE strategies is that the channel outputs are “scanned” in the latter two strategies to select the n channels with the highest envelope signals prior to each frame of stimulation across electrodes. Stimulus pulses are delivered only to the subset of m electrodes that correspond to the n selected channels. This spectral or channel “peak picking” scheme is designed, in part, to reduce the density of stimulation while still representing the most important aspects of the acoustic environment. The deletion of low-amplitude channels (and associated stimuli) for each frame of stimulation may reduce the overall level of masking or interference across electrode and stimulus regions in the cochlea. To the extent that the omitted channels do not contain significant information, such “unmasking” may improve the perception of the input signal by the patient. In addition, for positive signal-to-noise ratios (S/Ns), selection of the highest peaks in the spectra may emphasize the primary speech signal with respect to the noise. Detailed descriptions of these and related processing strategies, along with detailed descriptions of prior strategies, are presented in [9].

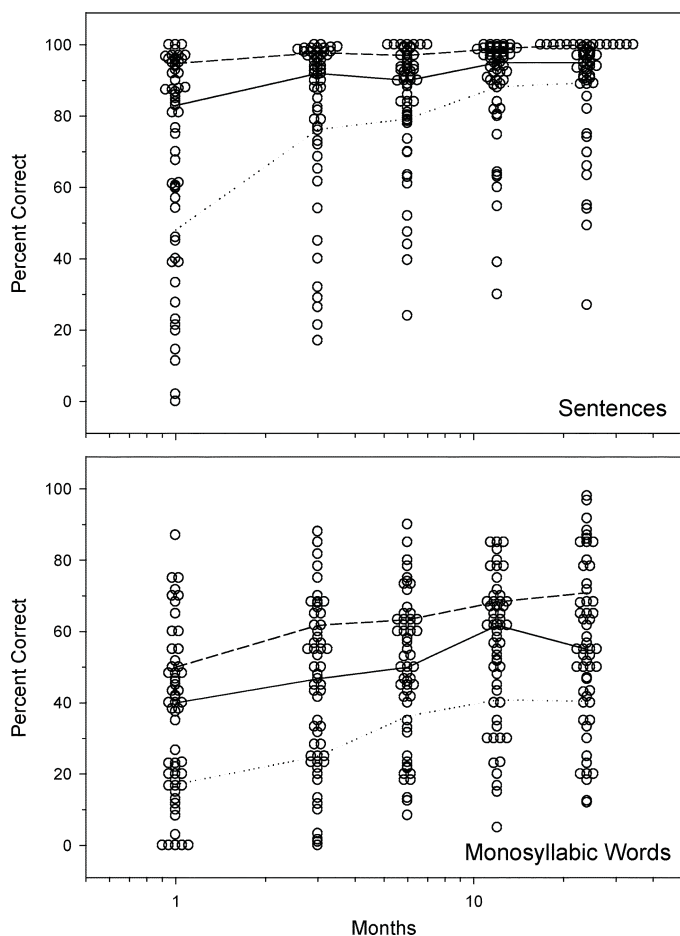

Fig. 5. Percent correct scores for 55 users of the COMBI 40 implant and the CIS processing strategy. Scores for recognition of the Hochmair-Schultz-Moser (HSM) sentences are presented in the top panel, and scores for recognition of the Freiburger monosyllabic words are presented in the bottom panel. The solid line in each panel shows the median of the scores, and the dashed and dotted lines show the interquartile ranges. The data are an updated superset of those reported in [32], kindly provided by Patrick D'Haese of Med El GmbH, in Innsbruck, Austria. The experimental conditions and implantation criteria are described in [32]. All subjects took both tests at each of the indicated intervals (1, 3, 6, 12, and 24 months) following initial fitting of their speech processors. Identical scores at a single test interval are displaced horizontally for clarity. Thus, for example, the horizontal "line" of scores in the top right portion of the top panel all represent scores for the 24-month test interval. (Figure is from [9] and is used here with the permission of Whurr Publishing, Ltd.)

IV. PERFORMANCE WITH PRESENT-DAY SYSTEMS

A. Average Performance and Range of Scores

Each of these strategies – CIS, ACE, and n -of- m – supports recognition of monosyllabic words on the order of 50% correct (using hearing alone), across populations of tested subjects (see [9, Table 2.4]). Variability in outcomes is high, however, with some patients achieving scores at or near 100% correct and with other patients scoring close to zero on this most difficult of standard audiological measures. Standard deviations of the scores range from about 10% to about 30% for the various studies conducted to date.

Results from a large and carefully controlled study are presented in Fig. 5. This figure shows scores for 55 users of the Med El COMBI 40 implant system (Med El GmbH, Innsbruck, Austria) and the CIS processing strategy. Scores for

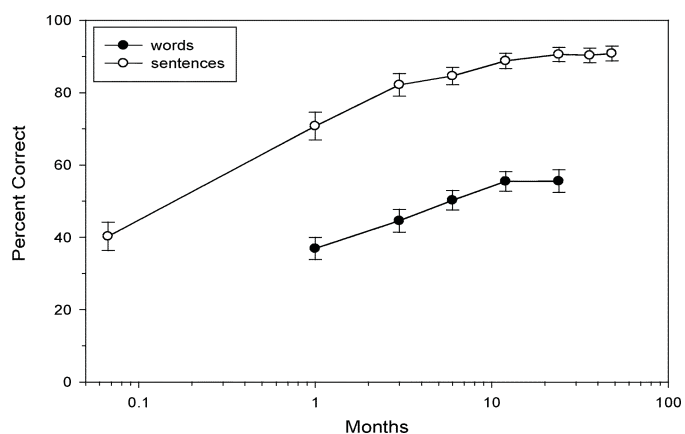

Fig. 6. Means and standard errors of the means for 54 of the 55 subjects in Fig. 5. (One of the subjects did not take the sentence test for the expanded range of intervals in this Fig. 6.) An additional interval before and two intervals after those indicated in Fig. 5 were used for the sentence test. (Figure is from [9] and is used here with the permission of Whurr Publishing, Ltd.)

the Hochmair-Schultz-Moser (HSM) sentences are presented in the top panel, and scores for recognition of the Freiburger monosyllabic words are presented in the bottom panel. Results for five measurement intervals are shown, ranging from one month to two years following the initial fitting of the speech processor. The solid line in each panel shows the median of the individual scores and the dashed and dotted lines show the interquartile ranges. The data are a superset of those reported in [32], that include scores for additional subjects at various test intervals.

Most of the subjects used an 8-channel processor with a pulse rate of about 1500/s/electrode. Some of the subjects used fewer channels and a proportionately higher rate. (All processors used the maximum overall rate of 12 120 pulses/s across electrodes.)

As is evident from the figure, scores are broadly distributed at each test interval and for both tests. However, ceiling effects are encountered for the sentence test for many of the subjects, especially at the later test intervals. At 24 months postfitting, 47 of the 55 subjects score at 75% correct or higher, consistent with the 1995 NIH Consensus Statement. Scores for recognition of monosyllabic words are much more broadly distributed, with only a few subjects scoring 90% correct or higher.

An interesting aspect of the results presented in Fig. 5 is an apparent improvement in performance over time. This is easiest to see in the lower ranges of scores, e.g., in the steady increase in the lower interquartile lines (the dotted lines) across test intervals.

Improvements over time are even more evident in plots of mean scores for sentences and for words, as shown in Fig. 6 for these same data and for additional test intervals for the sentence test. The mean scores increase for both the sentence and word tests out to twelve months and then plateau thereafter. The mean scores for the sentence test asymptote at about 90% correct, and the mean scores for the word test asymptote at about 55% correct. Such results typify performance with the best of the modern cochlear implant systems and processing strategies, for electrical stimulation on one side with a unilateral implant.

These results are especially remarkable for the top scorers, given that only a maximum of eight broadly overlapping sectors

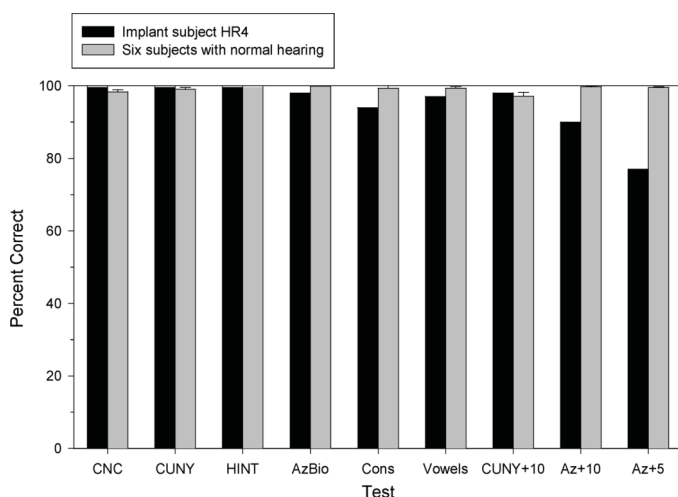

Fig. 7. Percent-correct scores for implant subject HR4 and for six subjects with normal hearing. Means and standard errors of the means are shown for the subjects with normal hearing. Tests included recognition of monosyllabic, consonant-nucleus-consonant (CNC) words; recognition of City University of New York (CUNY) sentences; recognition of Hearing in Noise Test (HINT) sentences; recognition of Arizona Biomedical Institute (AzBio) sentences; identification of consonants (Cons) in an /e/-consonant-/e/ context; identification of vowels (Vowels) in a /b/-vowel-/t/ context; and recognition of CUNY and AzBio (Az) sentences presented in competition with a four-talker babble, at the indicated speech-to-babble ratios (+5 or +10 dB). (Figure is from [33] and is used here with the permission of the IEEE.)

of the auditory nerve are stimulated with this device and the implementation of CIS used with it. This number is quite small in comparison to the normal complement of approximately 30 000 neurons in the human auditory nerve.

The results also show a learning or accommodation effect, with continuous improvements in scores over the first 12 months of use. This suggests the likely importance of brain function in determining outcomes, and the reorganization or “knitting” (brain plasticity) that must occur to utilize such sparse inputs to the maximum extent possible.

B. Top Performers

The top performers with present-day cochlear implants can achieve remarkably high scores in tests of speech recognition. Scores for one such subject, implant subject HR4, are shown in the black bars in Fig. 7 for a comprehensive and difficult set of tests. Mean scores for six undergraduate students with normal hearing and taking the same tests are shown in the gray bars, along with the standard error of the mean for each test. HR4 was totally deaf prior to receiving his implant. The tests included recognition of monosyllabic, consonant-nucleus-consonant (CNC) words (50 items); recognition of City University of New York (CUNY) sentences (24 sentences and approximately 200 words, depending on the lists used for each subject); recognition of Hearing in Noise Test (HINT) sentences (250 sentences and 1320 words, presented in quiet); recognition of Arizona Biomedical Institute (AzBio) sentences (40 sentences and approximately 270 words, depending on the lists used); identification of 20 consonants in an /e/-consonant-/e/ context (with 5 repetitions of the 20 in randomized orders); identification of 13 computer-synthesized vowels in a /b/-vowel-/t/ context (with 5 repetitions of the 13 in randomized orders); and

recognition of CUNY and AzBio sentences presented in competition with a four-talker babble, at the speech-to-babble ratio (S/B) of +10 dB for the CUNY sentences and that ratio and +5 dB for the AzBio sentences. Further details about the subjects, tests, and testing procedures are presented in [33].

Fig. 7 shows a spectacular restoration of function for a user of a sensory neural prosthesis. All of the scores for HR4 are high. His scores for speech material presented in quiet, including words, sentences, consonants, and vowels, match or closely approximate the scores for the control group. His score for the most difficult test used in standard clinical practice, recognition of the monosyllabic CNC words is 100% correct. In contrast, some of his scores for sentences presented in competition with speech babble are worse than normal. Although his score for the CUNY sentences at the S/B of +10 dB is 98% correct, his scores for the AzBio sentences at the S/Bs of +10 dB and +5 dB are below those of the normal-hearing subjects. In all, HR4 scored at or near the ceiling of 100% correct for seven of the nine tests, and he attained scores of 77% correct or better for the remaining two tests. (The subjects with normal hearing scored at or near the ceiling for all nine tests.) HR4 scored at the ceiling for all tests given in standard clinical practice to identify deficits in hearing. His results indicate a full restoration of clinically-normal function, at least for speech reception. He used a 16-channel CIS processor, as implemented in the Clarion® CII cochlear prosthesis (Advanced Bionics Corp., Sylmar, CA, USA) [34]. This prosthesis also includes a high-bandwidth transcutaneous link, current sources with short rise and fall times, an array of 16 intracochlear electrodes, and (in the version used) a positioning device to place the electrodes next to the inner wall of the ST.

Such high scores overall are consistent with HR4’s ability to communicate with ease in most listening situations. He has no difficulty at all in telephone communications. He can understand conversations not directed to him and can identify speakers by regional dialect. He can mimic voices and accents that he has heard only after receiving the implant. His speech reception abilities are truly remarkable, abilities that could not have been imagined 20 years ago, even by the most-optimistic proponents of cochlear implants.

Other patients, using this and other implant systems, and also other processing strategies (including the *n-of-m* and ACE strategies), have achieved similarly high scores. For example, one of the subjects in Fig. 5 achieved a score of 98% correct in the Freiburger monosyllabic word test at the two-year interval. This subject used a COMBI 40 implant system, with its eight channels of CIS processing and eight sites of stimulation. This system also has a high-bandwidth transcutaneous link and current sources with short rise and fall times. It does not include a positioning device; nor do other versions of the Clarion prosthesis or other implant systems, that also support stellar scores for some patients.

Although more than a few patients have achieved scores like those shown in Fig. 7, most patients have lower scores, typically much lower scores for the difficult tests, as also indicated in the lower panel of Fig. 5. However, the results obtained with HR4 and his peers are an existence proof of what is possible with electrical stimulation of the auditory nerve in a totally deafened ear.

V. STRENGTHS AND LIMITATIONS OF PRESENT SYSTEMS

A. Efficacy of Sparse Representations

Some patients achieve spectacularly high scores with present-day cochlear implants. Indeed, their scores are in the normal ranges even for the most difficult of standard audiological tests. Such results are both encouraging and surprising in that the implants provide only a very crude mimicking of only some aspects of the normal physiology. In cases like that of patient HR4, 16 overlapping sectors of the auditory nerve are stimulated with 16 intracochlear electrodes. In other cases, other patients have achieved similarly high scores with 6–8 sites of stimulation in the cochlea, as noted above. The spatial specificity of stimulation with implants is much lower than that demonstrated in neural tuning curves for normal hearing [35], especially for monopolar stimulation, which is used in all present-day systems. Such broad and highly overlapping activation of the nerve most likely limits the number of perceptually separable channels to 4–8, even if more than eight electrodes are used, as also noted before. The information presented through the implant is limited to envelope variations in the 16 or fewer frequency bands for these patients. (Similar numbers apply for patients also achieving high scores but using processing strategies other than CIS.) For HR4 and others, the upper frequency of envelope variations has been set at 200–700 Hz [9], e.g., by using a cutoff frequency in the range of 200–700 Hz for the low-pass filters in the envelope detectors shown in Fig. 4. A substantial fraction of this information may be perceived by the better patients [36]–[38], and whatever is perceived is sufficient for high levels of speech recognition.

The performance achieved by HR4 and the others like him brings into question the significance for speech reception of the intricate processing, and the interplay between and among processing steps, that occur in the normal cochlea. The details of the traveling wave of mechanical displacements along the BM in response to acoustic stimuli [39], and the spatial sharpening of the membrane response by active processes at the outer hair cells (OHCs) [39], [40], are not necessary for effective representations of speech information. Also, the noninstantaneous compression function at the synapses between the IHCs and single fibers of the auditory nerve [41] is not necessary. Additional aspects of normal hearing that are not replicated with implants include multiple stages of compression (at the BM/OHC complex, at the IHCs, and at the IHC/neuron synapses); effects of efferent action on the OHCs and other structures in the cochlea [42]; the broad distributions of thresholds for the multiple afferent fibers innervating each IHC [43]; and effects of spontaneous activity in the nerve [44], which is absent or largely absent in the deafened ear [45]–[47]. Despite these many missing steps or severed connections, cochlear implants can restore clinically normal function in terms of speech reception for some patients. This is remarkable.

B. Variability in Outcomes

One of the major remaining problems with cochlear implants is the broad distribution of outcomes, especially for difficult tests and as exemplified in the bottom panel of Fig. 5. That is, patients using exactly the same implant system—with the same

speech processor, transcutaneous link, implanted receiver/stimulator, and implanted electrode array—can have scores ranging from the floor to the ceiling for such tests. Indeed, only a small fraction of patients achieve the spectacularly high scores discussed above.

C. Likely Importance of Cortical Function

Accumulating and compelling evidence is pointing to differences in cortical or auditory pathway function as a likely contributor to the variability in outcomes with cochlear implants. On average, patients with short durations of deafness prior to their implants fare better than patients with long durations of deafness [48]. This may be the result of sensory deprivation for long periods, which adversely affects connections between and among neurons in the central auditory system [49] and may allow encroachment by other sensory inputs of cortical areas normally devoted to auditory processing (this encroachment is called “cross-modal plasticity,” see [50] and [51]). Although one might think that differences in nerve survival at the periphery could explain the variability, either a negative correlation or no relationship has been found between the number of surviving ganglion cells and prior word recognition scores, for deceased implant patients who in life had agreed to donate their temporal bones (containing the cochlea) for postmortem histological studies [52]–[55]. In some cases, survival of the ganglion cells was far shy of the normal complement, and yet these same patients achieved high scores in monosyllabic word tests. Conversely, in some other cases, survival of the ganglion cells was excellent, and yet these patients did not achieve high scores on the tests. Although some number of ganglion cells must be required for the function of a cochlear implant, this number appears to be small. Above that putative threshold, the brains of the better-performing patients apparently can utilize a sparse input from even a small number of surviving cells for high levels of speech reception.

Similarly, it seems likely that representation of speech sounds with the cochlear implant needs to be above some threshold in order for the brain to utilize the input for good speech reception. Single-channel implant systems did not rise above this second putative threshold; nor did prior processing strategies for multichannel implants. The combination of multiple sites of stimulation in the cochlea (at least 6–8), relatively new processing strategies such as the CIS, *n*-of-*m*, and ACE strategies, and some minimum survival of ganglion cells is sufficient for a high restoration of function in some patients. Those patients are likely to have intact “auditory brains” that can utilize these still sparse and distorted inputs, compared with the inputs the brain receives from the normal cochlea.

Other patients may not have the benefit of normal or nearly normal processing central to the auditory nerve. The effects of auditory deprivation for long periods have been mentioned. In addition, the brains of children become less “plastic” or adaptable to new inputs beyond their third or fourth birthdays. This may explain why deaf children implanted before then generally have much better outcomes than deaf children implanted at age five and older [50], [56], [57].

The brain may be the “tail that wags the dog” in determining outcomes with present-day cochlear implants. The brain “saves

us” in achieving high scores with those implants, in somehow utilizing a crude and sparse and distorted representation at the periphery. In addition, strong learning or accommodation effects—over long periods ranging from about three months to a year or more—indicate a principal role of the brain in reaching asymptotic performance with implants (see Fig. 6). Multiple lines of evidence further indicate or suggest that impairments in brain function—including damage to the auditory pathways in the brainstem, or compromised function in the areas of cortex normally devoted to auditory processing, or reduced cortical plasticity, or cross-modal plasticity—can produce highly deleterious effects on results obtained with cochlear implants.

D. Likely Importance of Electrode Designs

Present designs and placements of electrodes for cochlear implants do not support more than 4–8 effective sites of stimulation, or effective or functional channels, as described in Section III-C above. Contemporary cochlear implants use between 12 and 22 intracochlear electrodes, so the number of electrodes exceeds the number of effective channels (or sites of stimulation) for practically all patients and for all current devices. The number of effective channels depends on the patient and the speech reception measure to evaluate performance. For example, increases in scores with increases in the number of active electrodes generally plateau at a lower number for consonant identification than for vowel identification. (This makes sense from the perspective that consonants may be identified with combinations of temporal and spectral cues, whereas vowels are identified primarily or exclusively with spectral cues, that are conveyed through independent sites of stimulation.) Patients with low speech reception scores generally do not have more than four effective channels for any test, whereas patients with high scores may have as many as eight or slightly more channels depending on the test (e.g., [18] and [58]).

Results from studies using acoustic simulations of implant processors and subjects with normal hearing indicate that a higher number of effective channels or sites of stimulation for implants could be beneficial. Dorman *et al.* found, for example, that with the simulations and normal-hearing subjects, as many as ten channels are needed to reach asymptotic performance (for difficult tests) using a CIS-like processor [59]. Other investigators have found that even more channels are needed for asymptotic performance, especially for difficult tests such as identification of vowels or recognition of speech presented in competition with noise or a multi-talker babble [18], [60]. For example, Friesen *et al.* found that identification of vowels for listeners with normal hearing continued to improve with the addition of channels in the acoustic simulations up to the tested limit of 20 channels, for vowels presented in quiet and at progressively worse speech-to-noise ratios out to and including +5 dB [18].

Large improvements in the performance of cochlear implants might well be obtained with an increase in the number of effective sites of stimulation, which would help narrow the gap between implant patients and subjects with normal hearing. This gap is especially wide for the many patients who do not have more than four functional channels across wide ranges of speech

reception measures. Just a few more channels for the top performers with implants would almost without doubt help them in listening to speech in demanding situations, such as speech presented in competition with noise or other talkers. An increase in the number of functional channels for patients presently at the low end of the performance spectrum could improve their outcomes substantially.

A highly plausible explanation for the limitation in effective channels with implants is that the electric fields from different intracochlear electrodes strongly overlap at the sites of neural excitation (e.g., [58] and [61]). Such overlaps (or electrode interactions) may well impose an upper bound on the number of electrodes that are sufficiently independent to convey perceptually separate channels of information. In addition, a central processing deficit may contribute to the limitation, perhaps especially for patients with low speech reception scores and (usually) a relatively low number of effective channels.

A problem with ST implants is that the electrodes are relatively far from the target tissue (the spiral ganglion), even for placements of electrodes next to the inner wall of the ST. Close apposition of the target and the electrode is necessary for a high spatial specificity of stimulation [62]. One possibility for providing a close apposition is to promote the growth of neurites from the ganglion cells toward the electrodes in the ST with controlled delivery of neurotrophic drugs into the perilymph [63]–[66]. Such growth of neurites would bring the target to the electrodes. Another possibility is to implant an array of electrodes directly within the auditory nerve (an intramodiolar implant), through an opening made in the basal part of the cochlea [24]–[26], [28]–[30]. In this case, the electrodes would be placed immediately adjacent to axons of the auditory nerve. Studies are underway to evaluate each of these possibilities, including safety and efficacy studies. Results from studies to evaluate the intramodiolar implant have demonstrated that it is feasible and that the number of independent sites of stimulation with that implant may be substantially higher than the number for ST implants [29], [30].

E. Recent Advances

Two recent advances in the design and performance of cochlear implants are: 1) electrical stimulation of both ears with bilateral cochlear implants and 2) combined electric and acoustic stimulation (EAS) of the auditory system for persons with residual hearing at low frequencies. Bilateral electrical stimulation may reinstate at least to some extent the interaural amplitude and timing difference cues that allow people with normal hearing to lateralize sounds in the horizontal plane and to selectively “hear out” a voice or other source of sound from among multiple sources at different locations. Additionally, stimulation on both sides may allow users to make use of the acoustic shadow cast by the head for sound sources off the midline. In such cases, the S/N may well be more favorable at one ear compared with the other for multiple sources of sound, and users may be able to attend to the ear with the better S/N. Combined EAS may preserve a relatively normal hearing ability at low frequencies, with excellent frequency resolution and other attributes of normal hearing, while providing a complementary representation of high-frequency sounds with the

cochlear implant and electrical stimulation. Various surgical techniques and drug therapies have been developed to preserve low-frequency hearing in an implanted cochlea, including deliberately shallow insertions of the electrode array (6, 10, or 20 mm) so as not to damage the apical part of the cochlea and remaining hair cells there; insertion of the electrode array through the round window membrane rather than through a cochleostomy to eliminate deleterious effects of drilling (loud and possibly damaging levels of noise, introduction of blood and bone dust into the perilymph, possible damage to delicate cochlear structures such as the BM); use of “soft surgery” techniques to minimize trauma; use of thin and highly flexible electrodes; use of a lubricant such as hyaluronic acid to facilitate insertion of the array; and use of corticosteroids and other drugs to help preserve cochlear structures in the face of surgical manipulations and the introduction of a foreign body into the inner ear. Moderate-to-excellent preservation of residual hearing has been reported using the shallow insertions and some or all of the additional procedures and techniques just mentioned [67]–[80]. Among the tested methods, insertion through the round window for placement of 20 mm arrays or use of shorter arrays have produced especially good results [77], [80]–[82]. The “soft surgery” methods also have been identified as important (e.g., [76] and [83]). Studies aimed at the further development of surgical techniques, adjunctive drug therapies, and special electrode arrays are in progress; both short- and long-term preservation of residual hearing in an implanted cochlea remain as major challenges and concerns.

Each of these approaches—bilateral electrical stimulation and combined EAS—has produced large improvements in speech reception performance compared with control conditions. In particular, bilateral stimulation can provide a substantial benefit in recognizing difficult speech materials such as monosyllabic words and in recognizing speech presented in competition with spatially distinct noise, in comparison to scores obtained with either unilateral implant alone [38], [84]–[100]. In addition, use of both implants supports an improved ability to lateralize sounds, again compared with either unilateral implant [86], [89], [90], [92], [93], [97], [98], [100]–[105]. (This ability is nonexistent or almost nil with a unilateral implant.) Combined EAS also provides a substantial benefit for listening to speech in noise or in competition with a multi-talker babble, compared with either electric stimulation only or acoustic stimulation only [38], [67], [68], [70], [71], [73], [75]–[79], [106]–[110]. Indeed, in some cases the score for combined EAS is greater than the sum of the scores for the electric-only and acoustic-only conditions. This has been described as a synergistic effect [38], [71], [75], [106], [111]. In addition, identification of melodies and reception of musical sounds is greatly improved with combined EAS compared with electric stimulation alone [73], [78], [109], [112], [113]. (Scores with acoustic stimulation alone closely approximate the scores with combined EAS, for melody and music reception.)

These gains from bilateral electrical stimulation most likely arise from the head shadow effect and a partial or full restoration of the binaural difference cues, as suggested above. In addition, gains may result from a “binaural summation” effect that is produced in normal hearing by redundant stimulation on the two

sides. Detailed descriptions of these various contributors to an overall binaural benefit for normal hearing and possible contributors for prosthetic hearing are presented in [38]. The evidence to date indicates that almost all recipients of bilateral cochlear implants benefit from the head shadow effect and that some benefit from: 1) the binaural squelch effect that is made possible with presentation and perception of the binaural timing-difference cue; 2) the binaural summation effect; or 3) both. The largest contributor to improvements in listening to speech presented in competition with spatially distinct noise is the head shadow effect, which is a physical effect that is present and can be utilized whether or not the binaural processing mechanism in the brainstem is intact.

In addition to these binaural effects that occur in normal hearing and to a variable extent in prosthetic hearing, electric stimulation on both sides may help fill “gaps” in the representation of frequencies on one side—due to uneven survival of spiral ganglion cells along the cochlear spiral—with complementary excitation of surviving neurons at the same frequency place on the contralateral side. For example, a lack of input to the central nervous system (CNS) at the 5 kHz position on one side may be at least partly bridged or compensated by stimulation of remaining neurons at the 5 kHz position in the other ear. This mechanism and the binaural summation effect may underlie the large improvements observed with bilateral implants for the recognition of difficult speech material presented from in front of the subjects and without any interfering noise, where the interaural difference cues and the head shadow effect do not come into play. The mechanism also may contribute to the good results observed for other conditions, in which the difference cues and the head shadow effect are also present.

A further possible mechanism contributing to the observed benefits of bilateral electric stimulation is a higher number of effective channels. Bilateral implants, in general, provide a doubling or near doubling of physical stimulus sites, compared with either unilateral implant alone. This may provide some gain in the number of effective channels, especially in cases of uneven nerve survival across the two sides, where stimulation of an area on one side that is “dead” on the other side may add an effective channel. As noted before, even a small gain in the number of effective channels could produce a large benefit, particularly for patients who otherwise would have low levels of performance and particularly for reception of difficult speech materials or for listening to speech in adverse S/N conditions.

An example of findings from studies with recipients of bilateral implants is presented in Fig. 8. These results are from studies conducted by Müller and coworkers at the Julius–Maximilians Universität in Würzburg, Germany [87]. Nine subjects participated. The left and middle columns of panels show individual and average scores for the recognition of sentences presented in competition with speech-spectrum noise at the S/N of +10 dB and with the sentences presented through a loudspeaker in front of the subject and the noise presented through a loudspeaker to the right of the subject (left column) or to the left of the subject (middle column). The right column shows results for the recognition of monosyllabic words in quiet, presented from the loudspeaker in front of the subject. For the sentence tests, the difference in scores

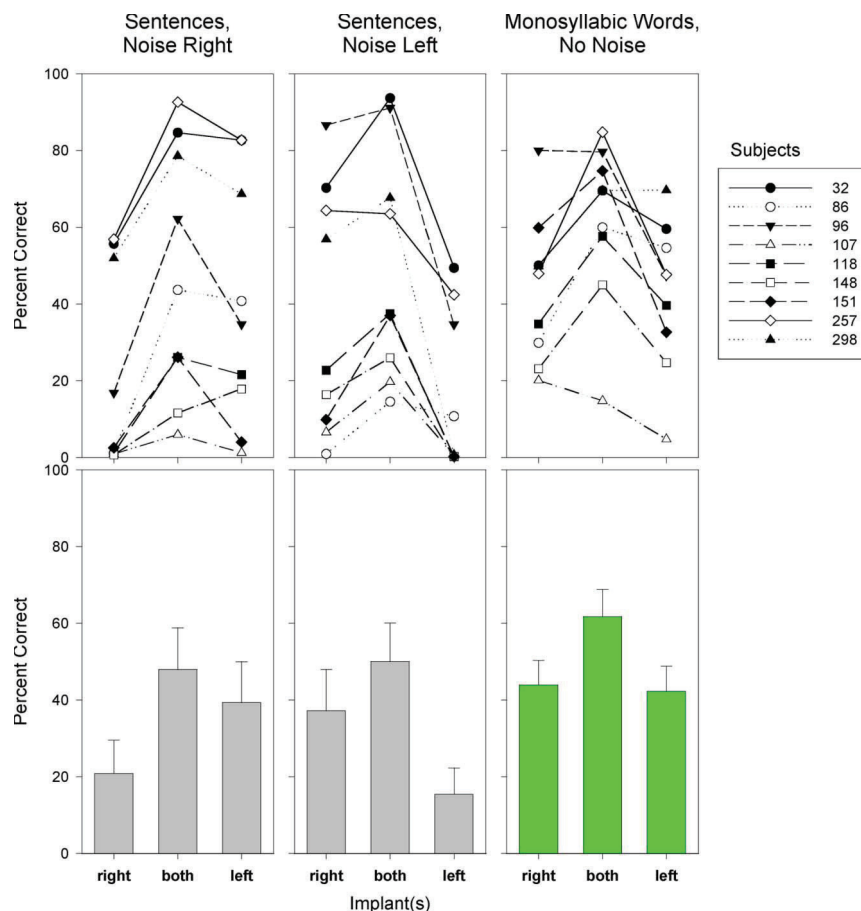

Fig. 8. Results from studies conducted by Müller *et al.* with nine recipients of bilateral cochlear implants [87]. The top panels show speech reception scores for the individual subjects, and the bottom panels show the means and standard errors of the means. The left and middle columns of panels show results for identification of words in Hochmair–Schultz–Moser (HSM) sentences presented in competition with CCITT speech-spectrum noise, at the speech-to-noise ratio of +10 dB. The right column shows results for recognition of Freiburg monosyllabic words presented in quiet. Each panel shows scores obtained with the right implant only, both implants, and the left implant only. Speech was presented from a loudspeaker 1 m in front of the subject for all tests, and noise was presented from a loudspeaker 1 m to the right of the subject for the tests depicted in the left column, and from a loudspeaker 1 m to the left of the subject for the tests depicted in the middle column. The highlighted area indicates the efficacy of bilateral stimulation even for conditions without interfering noise and in the absence of binaural difference cues. (Figure is from [38] and is used here with the permission of the *Annual Reviews*.) (A color version of this figure is available online at <http://ieeexplore.ieee.org>.)

for the left implant only versus the right implant only shows the magnitude of the head shadow benefit, which is large (see lower-left and lower-middle panels). For these same tests, the difference in scores for the bilateral condition versus the score for the single implant at the side opposite to the noise source shows the magnitude of a “binaural processing benefit,” which is a combination of binaural squelch, binaural summation, and possibly other effects. This binaural processing benefit is smaller than the head shadow benefit but still significant. For the word test (right column), the difference in scores between the bilateral condition and either of the unilateral conditions may be attributable to a binaural summation effect, or a filling of gaps in nerve survival across the two sides, or a principal contribution from the better of the two ears, or a higher number of effective channels, or some combination of these, for the bilateral condition. The improvement obtained with stimulation on both sides is large, comparable to the head shadow benefits demonstrated by the results from the sentence tests. This improvement is larger than what would be expected from binaural summation effects alone.

The gains from combined EAS may arise from a normal or nearly normal input to the CNS for low-frequency sounds from

the acoustic stimulation, in conjunction with a crude representation of high-frequency sounds from the electric stimulation with a partially inserted cochlear implant. The CNS apparently is able to integrate these seemingly disparate inputs into a single auditory percept, that is judged as sounding natural and intelligible. The likely ability to separate different “auditory streams” on the basis of different fundamental frequencies (and trajectories of fundamental frequencies) for different sounds may at least in part underlie the large advantages produced with combined EAS compared with electric stimulation only [77], [108], [109], [114], [115]. In particular, these fundamental frequencies (and one or more of their first several harmonics) occur at low frequencies and are within the range of residual hearing for most if not all users of combined EAS, i.e., below 500–1000 Hz. Perception and utilization of fine frequency differences in this range may allow an effective separation of a signal from interfering sounds. Also, the likely ability to “track” low frequencies almost certainly underlies the large improvements in melody recognition and music reception that have been reported (e.g., [113]).

Each of these relatively new approaches utilizes or reinstates a part of the natural system. Two ears are better than one, and

use of even a part of normal or nearly normal hearing at low frequencies can provide a highly significant advantage.

F. Possibilities for Further Improvements

Tremendous progress has been made in the design and performance of cochlear prostheses. However, much room remains for improvements. Patients with the best results still do not hear as well as listeners with normal hearing, particularly in demanding situations such as speech presented in competition with noise or other talkers. Users of standard unilateral implants do not have much access to music and other sounds that are more complex than speech. Most importantly, speech reception scores still vary widely across patients for relatively difficult tests, such as recognition of monosyllabic words, with any of the implant systems now in widespread use.

Fortunately, major steps forward have been made recently and many other possibilities for further improvements in implant design and function are on the horizon. Electrical stimulation on both sides with bilateral cochlear implants, and combined EAS for persons with some residual hearing, have been mentioned. These are new approaches, which may well be refined or optimized for still higher levels of performance. Some of the possibilities for such improvements are just now being explored, including development and evaluation of surgical techniques and adjunctive therapies aimed at the preservation of residual hearing in an implanted cochlea. In addition, other approaches—such as reinstatement of spontaneous-like activity in the auditory nerve [116], representation of “fine structure” or “fine frequency” information with novel patterns of electric stimuli [117]–[119], or a closer mimicking of the processing that occurs in the normal cochlea [118], [120]—may also produce improvements in performance, especially for patients with good or relatively good function in the central auditory pathways and in the cortical areas that process auditory information.

Further improvements for all patients might be produced by somehow increasing the number of effective channels supported by cochlear implants. Several possibilities for this have been mentioned, including intramodiolar implants and drug-induced growth of neurites toward the electrodes of ST implants. An additional possibility is to regard bilateral implants as a collection of many stimulus sites and to choose for activation the perceptually separable sites among them. Alternatively, one might “interlace” stimulus sites across the two sides, where the most basal region of one cochlea is stimulated on one side, the next most basal region on the other side, the next most basal region on the first side, and so forth until the full tonotopic map is spanned. In this way, all the frequencies would be represented but the distance between active electrodes in each implant would be doubled, which would in turn reduce the interactions among them, compared with stimulation of adjacent electrodes. These different ways of using bilateral implants have the potential to increase the number of effective channels [38], [121], but almost certainly at the cost of diminishing or eliminating a useful representation of the binaural difference cues. This may be a good tradeoff for some patients.

Each of the approaches described above is aimed at improving the representation at the periphery. A fundamentally new approach may be needed to help those patients presently at the low end of the performance spectrum, however. They may

have compromised “auditory brains” as suggested above and by many recent findings. For them, a “top-down” or “cognitive neuroscience” approach to implant design may be more effective than the traditional “bottom-up” approach. In particular, the new (top-down) approach would ask what the compromised brain needs as an input in order to perform optimally, in contrast to the traditional approach of replicating insofar as possible the normal patterns of activity at the auditory nerve. The patterns of stimulation specified by the new approach are quite likely to be different from the patterns specified by the traditional approach.

A related possibility that may help all patients at least to some extent is directed training to encourage and facilitate desired plastic changes in brain function (or, to put it another way, to help the brain in its task to learn how to utilize the inputs from the periphery provided by a cochlear implant). Such training, if well designed, may shorten the time needed to reach asymptotic performance and may produce higher levels of auditory function at that point and beyond. The ideal training procedure for an infant or young child may be quite different from the ideal procedure for older children or adults due to differences in brain plasticity. For example, the “step size” for increments in the difficulty of a training task may need to be much smaller for adults than for infants and young children [122]. However, all patients may benefit from appropriately designed procedures, that respect the differences in brain plasticity according to age.

The brain is a critical part of a prosthesis system. For patients with a fully intact brain, the “bottom-up” approach to implant design probably is appropriate, i.e., an ever-closer approximation to the normal patterns of neural discharge at the periphery is likely to provide the inputs that the brain “expects” and is configured to receive and process. For patients with a compromised brain, such inputs may not be optimal. In those cases, a “top-down” approach to implant design, or a combination of “top-down” and “bottom-up” approaches, may produce the best results. For example, a “top-down” approach combined with techniques to minimize electrode interactions at the periphery may be especially effective for patients presently shackled with poor outcomes.

VI. INTERFACING SENSORS WITH THE NERVOUS SYSTEM

The full restoration of clinically normal function with a cochlear implant, as demonstrated by the findings for subject HR4 (Fig. 7) and others like him, bodes well for the development of other types of sensory neural prostheses. In particular, a sparse and distorted representation at the periphery may be sufficient for restoration of high levels of function for other sensory inputs as well, e.g., visual or vestibular inputs. As with cochlear implants, a putative threshold of the amount and quality of information in the peripheral representation may need to be exceeded before good outcomes can be achieved. However, this threshold may be quite low and a full replication of the exquisite and complex machinery at the periphery is certainly not necessary for the restoration of useful hearing and may not be necessary for the restoration of other senses either.

That said, reproduction of some aspects of the normal physiology is likely to be important. In cochlear implants, for example, a crude replication of the normal tonotopic representa-

tion of frequencies—with multichannel processing strategies and with multiple (and perceptually separable) sites of stimulation in the cochlea—was necessary to achieve high levels of performance. Perhaps a topographic representation would work well for a visual prosthesis, as has been suggested (e.g., [123]–[133]). As with cochlear implants, we expect some threshold of resolution in the stimulation will need to be exceeded for good function, and that the difficult problems of electrode interactions will need to be addressed for useful restoration of vision and other senses. However, the threshold may be surprisingly low. (A low threshold may be essential for a successful visual prosthesis, as the optic nerve has 1.2 million ganglion cells and associated axons, that receive inputs from 125 million photoreceptors in the retina. These numbers are substantially higher than the corresponding numbers for the cochlea, e.g., 1.2 million neurons in the optic nerve versus 30 000 neurons in the auditory nerve. The complexity of the retina and strategies for electrical stimulation using epiretinal or subretinal arrays, or electrical stimulation at more central sites in the visual pathway, are discussed in [123]–[127], [131], and [134]–[137].)

In addition, an intact or largely intact brain may well be a prerequisite for a topographic representation to work, at least initially and without training. Further, effects of cross-modal plasticity may preclude a good outcome with any type of sensory neural prosthesis, although a training approach has been proposed to mitigate or even possibly reverse these effects [125], [126].

An important consideration in the design of sensory neural prostheses is to regard the brain as a key part of the overall system. The brain of the user should be respected for what it does, and the design should foster a partnership between the brain and the prosthesis, perhaps with communications in both directions, i.e., from the brain to the prosthesis as well as from the prosthesis to the brain. Indeed, this was a principal theme of the *Smart Prosthetics* conference held at the Beckman Center, University of California, Irvine, in November 2006 and sponsored by the Keck Foundation and National Academies Futures Initiative, see <http://www.keckfutures.org/> and the daughter pages. We expect this more holistic approach will be embraced in future designs.

The path between a sensor or an array of sensors and useful perception involves many steps and considerations. The path can be traversed, though, as demonstrated by cochlear implants.

VII. SUMMARY

In summary, the experience with cochlear implants either indicates or suggests the following.

- Experts can be stunningly wrong in assessments of a new approach or technology; perseverance in the face of intense criticism was essential for the successful development of cochlear implants and this may prove to be the case for other types of neural prostheses as well.
- The above is not an argument for wayward or uninformed efforts, of course, and the NIH vetted cochlear implants with the Bilger study [4] before investing many millions of dollars for the further development of implant systems. Still, though, the courage to take informed risks on the part of the NIH and the investigators (including the investigators worldwide who were supported by agencies other than the NIH) was as important as anything else in moving this marvelous technology forward; in addition, some of the earlier efforts that appeared to many to be wayward at the time later proved to be prescient.
- Multidisciplinary efforts of multiple teams were required to make the cochlear implant a success, and NIH support of a large number of these efforts was critically important. Development of other types of neural prostheses without these elements in place seems unimaginable.
- A decidedly sparse and crude and distorted representation at the periphery supports a remarkable restoration of function for some users of present-day cochlear implants. This bodes well for the development of vestibular, visual, or other types of sensory neural prostheses.
- However, this representation must exceed some putative threshold of quality and quantity of information. Most likely, this means that aspects of the normal physiology need to be mimicked or reinstated to some minimal extent. The experience with cochlear implants indicates that 1) not all aspects of the normal physiology need to be reproduced and 2) those aspects that are reinstated do not have to be perfectly reproduced by any means. Present-day implants—with multiple channels of processing, multiple sites of stimulation in the cochlea, and the CIS, *n*-of-*m*, ACE, or other modern processing strategies—have exceeded the putative threshold for the great majority of patients, in that most patients score at 80% correct or higher in sentence tests using hearing alone and many patients can use the telephone without difficulty. Prior implant systems did not exceed the threshold.
- Not surprisingly, the interface to the tissue is important. Present electrode arrays for cochlear implants do not support more than 4–8 functional channels even though the number of stimulating electrodes is higher than that. Overlapping excitation fields from different electrodes almost certainly degrade their independence; this is a general problem with neural prostheses that map outputs to thousands of neurons in very close proximity to each other, as in the retina.
- Interlacing of stimulus pulses across electrodes—such that only one electrode is active at any one time—has proved to be highly effective for cochlear implants in achieving the present levels of electrode and channel independence. Such interlacing of stimuli may be effective for other types of neural prostheses. In addition, novel electrode designs, placements of electrodes in close proximity to the target neurons, drug treatments to encourage the growth of neural tissue toward electrodes, or interlacing of stimuli across bilateral implants (e.g., across implants for each retina), or combinations of these, may well increase the number of functional sites of stimulation for cochlear, as well as other types of sensory neural prostheses.
- Any residual function should be preserved and utilized to the maximum extent possible, in conjunction with the prosthesis, as in combined electric and acoustic stimulation of the auditory system for persons with some residual (low-frequency) hearing.
- For sensory systems with bilateral inputs—audition, vision, and balance—reinstatement of inputs on both sides may confer large benefits to users of prosthetic systems, as

demonstrated by the experience with bilateral cochlear implants.

- Percutaneous access to the implanted electrodes may provide important advantages in the initial development of any sensory neural prosthesis, as certainly was the case with cochlear implants.
- Good results take time. Asymptotic performance is not achieved with cochlear implants until at least three months of daily use and in many cases longer or much longer than that. This and other findings indicate a principal role of the brain in determining outcomes with implants. It also indicates that results from acute studies may be misleading in that they may grossly underestimate the potential of an approach. The brain is likely to be vitally important in determining outcomes with other types of neural prostheses as well, and effects of cross-modal plasticity may preclude good outcomes for persons who have been deprived of a sensory input for all or most of their lives, in that the “cortical target” for the input has been encroached or recruited by other sensory modalities and such effects may not be reversible. (Such effects have not been reversed thus far. However, this does not mean categorically that the task cannot be achieved. Merabet and coworkers have, for example, proposed a yet-to-be-tested training procedure to mitigate or reverse effects of cross-modal plasticity in the context of a visual prosthesis, see [126].)
- The power of the intact or largely intact brain to utilize sparse and distorted inputs is impressive; and this most likely underpins in large part the success of cochlear implants.
- A sensory prosthesis and the brain are “partners” in an overall system, and simply focusing on the periphery in the design of a prosthesis may provide good results for persons with fully intact brains and sensory pathways, but probably will limit results for persons with impaired pathways or impaired or altered cortical processing.
- The amount of information from the periphery that can be utilized may be increased through plastic changes in the brain, especially for infants and very young children but also for older patients, albeit at a likely slower pace of adaptation and perhaps to a lesser extent than with young children.
- Desired plastic changes may be facilitated and augmented through directed training; the optimal training procedure is likely to vary according to the age of the patient, to the duration of sensory deprivation prior to the restoration of (some) function with a prosthesis, and whether or not the sense was first lost prior to the “critical period” for the normal development of that sensory pathway and processing in the midbrain and cortex. Training may or may not be effective for patients who lost a sense prior to or during the critical period and had it reinstated (at least to some extent) after the critical period had expired. Training may be most effective for persons who lost the sense following the critical period, and after the sensory pathways and associated cortical processing had been established.
- The highly deleterious effects of cross-modal plasticity or missing the critical period for maturation of the central auditory pathways and cortex are “moral imperatives” to

screen infants for deafness or blindness or possibly other sensory losses and to provide at least some input to the appropriate part of the CNS if feasible and as soon as practicable for cases in which severe deficits are found.

- Cochlear implants are among the great success stories of modern medicine, and this has surprised many. Another surprise, with the development of another highly effective sensory neural prosthesis, is certainly possible.

ACKNOWLEDGMENT

The authors are grateful to the three anonymous reviewers for this paper, for their exceptionally thoughtful and constructive comments. Limited material for the paper was drawn from or adapted from several recent publications, [9], [33], [57].

DEDICATION: This paper is dedicated to F. T. Hambrecht, M.D., and W. J. Heetderks, M.D., Ph.D., whose vision, leadership, and scientific acumen made present-day neural prostheses possible.

REFERENCES

- [1] M. D. Eisen, “History of the cochlear implant,” in *Cochlear Implants*, S. B. Waltzman and J. T. Roland, Jr., Eds., 2nd ed. New York: Thieme Medical Publishers, 2006, pp. 1–10.
- [2] R. Finn, A. J. Hudspeth, J. Zwislocki, E. Young, and M. Merzenich, “Sound from silence: The development of cochlear implants,” in *Beyond Discovery: The Path from Research to Human Benefit*. Washington, DC: National Academy of Sciences, 1998, pp. 1–8.
- [3] J. K. Niparko and B. S. Wilson, “History of cochlear implants,” in *Cochlear Implants: Principles & Practices*, J. K. Niparko, K. I. Kirk, N. K. Mellon, A. M. Robbins, D. L. Tucci, and B. S. Wilson, Eds. Philadelphia: Lippincott Williams & Wilkins, 2000, pp. 103–107.
- [4] R. C. Bilger, F. O. Black, N. T. Hopkinson, E. N. Myers, J. L. Payne, N. R. Stenson, A. Vega, and R. V. Wolf, “Evaluation of subjects presently fitted with implanted auditory prostheses,” *Ann. Otol. Rhinol. Laryngol.*, vol. 86, no. 3, pt. 2, pp. 1–176, 1977.
- [5] National Institutes of Health, “Cochlear implants,” *NIH Consensus Statement*, vol. 7, no. 2, pp. 1–9, 1988.
- [6] B. S. Wilson, C. C. Finley, D. T. Lawson, R. D. Wolford, D. K. Eddington, and W. M. Rabinowitz, “Better speech recognition with cochlear implants,” *Nature*, vol. 352, pp. 236–238, 1991.
- [7] B. S. Wilson, C. C. Finley, J. C. Farmer, Jr., D. T. Lawson, B. A. Weber, R. D. Wolford, P. D. Kenan, M. W. White, M. M. Merzenich, and R. A. Schindler, “Comparative studies of speech processing strategies for cochlear implants,” *Laryngoscope*, vol. 98, pp. 1069–1077, 1988.
- [8] M. W. Skinner *et al.*, “Evaluation of a new spectral peak (SPEAK) coding strategy for the Nucleus 22 channel cochlear implant system,” *Amer. J. Otol.*, vol. 15, no. 2, pp. 15–27, 1994.
- [9] B. S. Wilson, “Speech processing strategies,” in *Cochlear Implants: A Practical Guide*, H. R. Cooper and L. C. Craddock, Eds., 2nd ed. London and Philadelphia: Whurr Publishers Ltd., 2006, pp. 21–69.
- [10] “National institutes of health, “Cochlear implants in adults and children,” *NIH Consensus Statement*, vol. 13, no. 2, pp. 1–30, 1995.
- [11] R. Hinojosa and M. Marion, “Histopathology of profound sensorineural deafness,” *Ann. N. Y. Acad. Sci.*, vol. 405, pp. 459–484, 1983.
- [12] M. Miura, I. Sando, B. E. Hirsch, and Y. Orita, “Analysis of spiral ganglion cell populations in children with normal and pathological ears,” *Ann. Otol. Rhinol. Laryngol.*, vol. 111, pp. 1059–1065, 2002.
- [13] P. A. Leake and S. J. Rebscher, “Anatomical considerations and long-term effects of electrical stimulation,” in *Auditory Prostheses: Cochlear Implants and Beyond*, F.-G. Zeng, A. N. Popper, and R. R. Fay, Eds. New York: Springer-Verlag, 2004, pp. 101–148.
- [14] D. T. Lawson, B. S. Wilson, M. Zerbi, and C. C. Finley, “Speech processors for auditory prostheses: 22 electrode percutaneous study – Results for the first five subjects,” Neural Prosthesis Program, National Institutes of Health, Bethesda, MD, 3rd Quart. Progress Rep., NIH Project NO1-DC-5-2103, 1996.
- [15] K. E. Fishman, R. V. Shannon, and W. H. Slaterry, “Speech recognition as a function of the number of electrodes used in the SPEAK cochlear implant speech processor,” *J. Speech Lang. Hear. Res.*, vol. 40, pp. 1201–1215, 1997.

- [16] B. S. Wilson, "The future of cochlear implants," *Brit. J. Audiol.*, vol. 31, pp. 205–225, 1997.
- [17] J. Kiefer, C. von Ilberg, J. Hubner-Egener, V. Rupprecht, and R. Knecht, "Optimized speech understanding with the continuous interleaved sampling speech coding strategy in cochlear implants: Effect of variations in stimulation rate and number of channels," *Ann. Otol. Rhinol. Laryngol.*, vol. 109, pp. 1009–1020, 2000.
- [18] L. M. Friesen, R. V. Shannon, D. Baskent, and X. Wang, "Speech recognition in noise as a function of the number of spectral channels: Comparison of acoustic hearing and cochlear implants," *J. Acoust. Soc. Amer.*, vol. 110, pp. 1150–1163, 2001.
- [19] C. Garnham, M. O'Driscoll, R. Ramsden, and S. Saeed, "Speech understanding in noise with a Med-EL COMBI 40+ cochlear implant using reduced channel sets," *Ear Hear.*, vol. 23, pp. 540–552, 2002.
- [20] L. T. Cohen, E. Saunders, M. R. Knight, and R. S. Cowan, "Psychophysical measures in patients fitted with contour and straight nucleus electrode arrays," *Hear. Res.*, vol. 212, pp. 160–175, 2006.
- [21] J. H. Frijns, J. J. Briaire, and J. J. Grote, "The importance of human cochlear anatomy for the results with modiolar-hugging multichannel cochlear implants," *Otol. Neurotol.*, vol. 22, pp. 340–349, 2001.
- [22] W. K. Gstoeftner, O. Adunka, P. Franz, J. Hamzavi, Jr., H. Plenk, Jr., M. Susani, W. Baumgartner, and J. Kiefer, "Perimodiolar electrodes in cochlear implant surgery," *Acta Otolaryngol.*, vol. 121, pp. 216–219, 2001.
- [23] T. J. Balkany, A. A. Eshraghi, and N. Yang, "Modiolar proximity of three perimodiolar cochlear implant electrodes," *Acta Otolaryngol.*, vol. 122, pp. 363–369, 2002.
- [24] H. A. Arts, D. A. Jones, and D. J. Anderson, "Prosthetic stimulation of the auditory system with intraneural electrodes," *Ann. Otol. Rhinol. Laryngol. Suppl.*, vol. 191, pp. 20–25, 2003.
- [25] A. N. Badi, T. R. Kertesz, R. K. Gurgel, C. Shelton, and R. A. Normann, "Development of a novel eighth-nerve intraneural auditory neuroprosthesis," *Laryngoscope*, vol. 113, pp. 833–842, 2003.
- [26] T. Hillman, A. N. Badi, R. A. Normann, T. Kertesz, and C. Shelton, "Cochlear nerve stimulation with a 3-dimensional penetrating electrode array," *Otol. Neurotol.*, vol. 24, pp. 764–768, 2003.
- [27] B. S. Wilson, "Engineering design of cochlear implant systems," in *Auditory Prostheses: Cochlear Implants and Beyond*, F.-G. Zeng, A. N. Popper, and R. R. Fay, Eds. New York: Springer-Verlag, 2004, pp. 14–52.
- [28] F. A. Spelman, "Cochlear electrode arrays: Past, present and future," *Audiol. Neurootol.*, vol. 11, pp. 77–85, 2006.
- [29] A. N. Badi, A. O. Owa, C. Shelton, and R. A. Normann, "Electrode independence in intraneural cochlear nerve stimulation," *Otol. Neurotol.*, vol. 28, pp. 16–24, 2007.
- [30] J. C. Middlebrooks and R. L. Snyder, "Auditory prosthesis with a penetrating array," *J. Assoc. Res. Otolaryngol.*, vol. 8, pp. 258–279, 2007.
- [31] J. Kiefer, S. Hohl, E. Sturzebecher, T. Pfennigdorff, and W. Gstoeftner, "Comparison of speech recognition with different speech coding strategies (SPEAK, CIS, and ACE) and their relationship to telemetric measures of compound action potentials in the Nucleus CI 24M cochlear implant system," *Audiology*, vol. 40, pp. 32–42, 2001.
- [32] J. Helms *et al.*, "Evaluation of performance with the COMBI 40 cochlear implant in adults: A multicentric clinical study," *ORL J. Otorhinolaryngol. Relat. Spec.*, vol. 59, pp. 23–35, 1997.
- [33] B. S. Wilson and M. F. Dorman, "The surprising performance of present-day cochlear implants," *IEEE Trans. Biomed. Eng.*, vol. 54, pp. 969–972, 2007.
- [34] J. H. M. Frijns, J. J. Briaire, J. A. P. M. de Laat, and J. J. Grote, "Initial evaluation of the Clarion CII cochlear implant: Speech perception and neural response imaging," *Ear Hear.*, vol. 23, pp. 184–197, 2002.
- [35] C. van den Honert and P. H. Stypulkowski, "Single fiber mapping of spatial excitation patterns in the electrically stimulated auditory nerve," *Hear. Res.*, vol. 29, pp. 195–206, 1987.
- [36] M. F. Dorman, P. C. Loizou, J. Fitzke, and Z. Tu, "Recognition of monosyllabic words by cochlear implant patients and by normal-hearing subjects listening to words processed through cochlear implant signal processing strategies," *Ann. Otol. Rhinol. Laryngol.*, vol. 185, no. 2000, pp. 64–66, 2000.
- [37] Q.-J. Fu, "Temporal processing and speech recognition in cochlear implant users," *NeuroReport*, vol. 13, pp. 1635–1639, 2002.
- [38] B. S. Wilson, D. T. Lawson, J. M. Müller, R. S. Tyler, and J. Kiefer, "Cochlear implants: Some likely next steps," *Annu. Rev. Biomed. Eng.*, vol. 5, pp. 207–249, 2003.
- [39] L. Robles and M. A. Ruggero, "Mechanics of the mammalian cochlea," *Physiol. Rev.*, vol. 81, pp. 1305–1352, 2001.
- [40] P. Dallos, "The active cochlea," *J. Neurosci.*, vol. 12, pp. 4575–4585, 1992.
- [41] R. L. Smith, "Cochlear processes reflected in responses of the cochlear nerve," *Acta Otolaryngol.*, vol. 100, pp. 1–12, 1985.
- [42] J. J. Guinan, Jr., "Physiology of olivocochlear efferents," in *The Cochlea*, P. Dallos, A. N. Popper, and R. R. Fay, Eds. New York: Springer, 1996, pp. 435–502.
- [43] M. C. Liberman, "Auditory-nerve response from cats raised in a low-noise chamber," *J. Acoust. Soc. Amer.*, vol. 63, pp. 442–455, 1978.
- [44] N. Y. S. Kiang, T. Watanabe, E. C. Thomas, and L. F. Clark, *Discharge Patterns of Single Fibers in the Cat's Auditory Nerve*. Cambridge, MA: MIT Press, 1965.
- [45] R. Hartmann, G. Topp, and R. Klinke, "Discharge patterns of cat primary auditory nerve fibers with electrical stimulation of the cochlea," *Hear. Res.*, vol. 13, pp. 47–62, 1984.
- [46] N. Y. S. Kiang, E. C. Moxon, and R. A. Levine, "Auditory-nerve activity in cats with normal and abnormal cochleas," in *Sensorineural Hearing Loss*, G. E. W. Wolstenholme and J. Knight, Eds. London, U.K.: J. and A. Churchill, 1970, pp. 241–273.
- [47] R. K. Shepherd and E. Javel, "Electrical stimulation of the auditory nerve. I. Correlation of physiological responses with cochlear status," *Hear. Res.*, vol. 108, pp. 112–144, 1997.
- [48] P. Blamey, P. Arndt, F. Bergeron, G. Bredberg, J. Brimacombe, G. Facer, J. Larky, B. Lindstrom, J. Nedzelski, A. Peterson, D. Shipp, S. Staller, and L. Whitford, "Factors affecting auditory performance of postlinguistically deaf adults using cochlear implants," *Audiol. Neurootol.*, vol. 1, pp. 293–306, 1996.
- [49] R. K. Shepherd and N. A. Hardie, "Deafness-induced changes in the auditory pathway: Implications for cochlear implants," *Audiol. Neurootol.*, vol. 6, pp. 305–318, 2001.
- [50] D. S. Lee, J. S. Lee, S. H. Oh, S. K. Kim, J. W. Kim, J. K. Chung, M. C. Lee, and C. S. Kim, "Cross-modal plasticity and cochlear implants," *Nature*, vol. 409, pp. 149–150, 2001.
- [51] D. Bavelier and H. J. Neville, "Cross-modal plasticity: Where and how?," *Nat. Rev. Neurosci.*, vol. 3, pp. 443–452, 2002.
- [52] J. B. Nadol, Jr., J. Y. Shiao, B. J. Burgess, D. R. Ketten, D. K. Eddington, B. J. Gantz, I. Kos, P. Montandon, N. J. Coker, J. T. Roland, Jr., and J. K. Shallop, "Histopathology of cochlear implants in humans," *Ann. Otol. Rhinol. Laryngol.*, vol. 110, pp. 883–891, 2001.
- [53] A. M. Khan, O. Handzel, B. J. Burgess, D. Damian, D. K. Eddington, and J. B. Nadol, Jr., "Is word recognition correlated with the number of surviving spiral ganglion cells and electrode insertion depth in human subjects with cochlear implants?," *Laryngoscope*, vol. 115, pp. 672–677, 2005.
- [54] J. N. Fayad and F. H. Linthicum, Jr., "Multichannel cochlear implants: Relation of histopathology to performance," *Laryngoscope*, vol. 116, pp. 1310–1320, 2006.
- [55] P. Blamey, "Are spiral ganglion cell numbers important for speech perception with a cochlear implant?," *Amer. J. Otol.*, vol. 18, no. 6, pp. S11–S12, 1997.
- [56] A. Sharma, M. F. Dorman, and A. J. Spahr, "Rapid development of cortical auditory evoked potentials after early cochlear implantation," *NeuroReport*, vol. 13, pp. 1365–1368, 2002.
- [57] M. F. Dorman and B. S. Wilson, "The design and function of cochlear implants," *Amer. Scientist*, vol. 92, pp. 436–445, 2004.
- [58] M. F. Dorman and A. J. Spahr, "Speech perception by adults with multichannel cochlear implants," in *Cochlear Implants*, S. B. Waltzman and J. T. Roland, Jr., Eds., 2nd ed. New York: Thieme Medical Publishers, 2006, pp. 193–204.
- [59] M. F. Dorman, P. C. Loizou, A. J. Spahr, and E. Maloff, "A comparison of the speech understanding provided by acoustic models of fixed-channel and channel-picking signal processors for cochlear implants," *J. Speech Lang. Hear. Res.*, vol. 45, pp. 783–788, 2002.
- [60] R. V. Shannon, Q.-J. Fu, and J. Galvin, III, "The number of spectral channels required for speech recognition depends on the difficulty of the listening situation," *Acta Otolaryngol.*, no. 552, pp. 50–54, 2004.
- [61] Q.-J. Fu and G. Nogaki, "Noise susceptibility of cochlear implant users: The role of spectral resolution and smearing," *J. Assoc. Res. Otolaryngol.*, vol. 6, pp. 19–27, 2004.
- [62] J. B. Ranck, Jr., "Which elements are excited in electrical stimulation of the mammalian central nervous system: A review," *Brain Res.*, vol. 98, pp. 417–440, 1975.
- [63] P. C. Roehm and M. R. Hansen, "Strategies to preserve or regenerate spiral ganglion neurons," *Curr. Opin. Otolaryngol. Head Neck Surg.*, vol. 13, pp. 294–300, 2005.

- [64] L. N. Pettingill, R. T. Richardson, A. K. Wise, S. J. O'Leary, and R. K. Shepherd, "Neurotrophic factors and neural prostheses: Potential clinical applications based upon findings in the auditory system," *IEEE Trans. Biomed. Eng.*, vol. 54, pp. 1138–1148, 2007.
- [65] D. Rejali, V. A. Lee, K. A. Abrashkin, N. Humayun, D. L. Swiderski, and Y. Raphael, "Cochlear implants and ex vivo BDNF gene therapy protect spiral ganglion neurons," *Hear. Res.*, vol. 228, pp. 180–187, 2007.
- [66] M. Vieira, B. L. Christensen, B. C. Wheeler, A. S. Feng, and R. Kollmar, "Survival and stimulation of neurite outgrowth in a serum-free culture of spiral ganglion neurons from adult mice," *Hear. Res.*, vol. 230, pp. 17–23, 2007.
- [67] C. von Ilberg, J. Kiefer, J. Tillein, T. Pfennigdorff, R. Hartmann, E. Stürzebecher, and R. Klinke, "Electric-acoustic stimulation of the auditory system. New technology for severe hearing loss," *ORL J. Otorhinolaryngol. Relat. Spec.*, vol. 61, pp. 334–340, 1999.
- [68] J. Kiefer, J. Tillein, C. von Ilberg, T. Pfennigdorff, E. Stürzebecher, R. Klinke, and W. Gstoettner, "Fundamental aspects and first results of the clinical application of combined electric and acoustic stimulation of the auditory system," in *Cochlear Implants – An Update*, T. Kubo, Y. Takahashi, and T. Iwaki, Eds. The Hague, The Netherlands: Kugler Publications, 2002, pp. 569–576.
- [69] H. Skarzynski, A. Lorens, P. D'Haese, A. Walkowiak, A. Piotrowska, L. Sliwa, and I. Anderson, "Preservation of residual hearing in children and post-lingually deafened adults after cochlear implantation: An initial study," *ORL J. Otorhinolaryngol. Relat. Spec.*, vol. 64, pp. 247–253, 2002.
- [70] B. J. Gantz and C. W. Turner, "Combining electric and acoustic hearing," *Laryngoscope*, vol. 113, pp. 1726–1730, 2003.
- [71] W. Gstoettner, J. Kiefer, W. D. Baumgartner, S. Pok, S. Peters, and O. Adunka, "Hearing preservation in cochlear implantation for electric acoustic stimulation," *Acta Otolaryngol.*, vol. 124, pp. 348–352, 2004.
- [72] J. Kiefer, W. Gstoettner, W. Baumgartner, S. M. Pok, J. Tillein, Q. Ye, and C. von Ilberg, "Conservation of low-frequency hearing in cochlear implantation," *Acta Otolaryngol.*, vol. 124, pp. 272–280, 2004.
- [73] B. J. Gantz, C. Turner, K. E. Gfeller, and M. W. Lowder, "Preservation of hearing in cochlear implant surgery: Advantages of combined electrical and acoustical speech processing," *Laryngoscope*, vol. 115, pp. 796–802, 2005.
- [74] C. James *et al.*, "Preservation of residual hearing with cochlear implantation: How and why," *Acta Otolaryngol.*, vol. 125, pp. 481–491, 2005.
- [75] J. Kiefer, M. Pok, O. Adunka, E. Stürzebecher, W. Baumgartner, M. Schmidt, J. Tillein, Q. Ye, and W. Gstoettner, "Combined electric and acoustic stimulation of the auditory system: Results of a clinical study," *Audiol. Neurootol.*, vol. 10, pp. 134–144, 2005.
- [76] B. Fraysse *et al.*, "Residual hearing conservation and electroacoustic stimulation with the Nucleus 24 contour advance cochlear implant," *Otol. Neurotol.*, vol. 27, pp. 624–633, 2006.
- [77] B. J. Gantz, C. Turner, and K. E. Gfeller, "Acoustic plus electric speech processing: Preliminary results of a multicenter clinical trial of the Iowa/Nucleus hybrid implant," *Audiol. Neurootol.*, vol. 11, no. 1, pp. 63–68, 2006.
- [78] W. K. Gstoettner, S. Helbig, N. Maier, J. Kiefer, A. Radeloff, and O. F. Adunka, "Ipsilateral electric acoustic stimulation of the auditory system: Results of long-term hearing preservation," *Audiol. Neurootol.*, vol. 11, no. 1, pp. 49–56, 2006.
- [79] H. Skarzynski, A. Lorens, A. Piotrowska, and I. Anderson, "Partial deafness cochlear implantation provides benefit to a new population of individuals with hearing loss," *Acta Otolaryngol.*, vol. 126, pp. 934–940, 2006.
- [80] H. Skarzynski, A. Lorens, A. Piotrowska, and I. Anderson, "Preservation of low frequency hearing in partial deafness cochlear implantation (PDCI) using the round window surgical approach," *Acta Otolaryngol.*, vol. 127, pp. 41–48, 2007.
- [81] O. Adunka, M. H. Unkelbach, M. Mack, M. Hambek, W. Gstoettner, and J. Kiefer, "Cochlear implantation via the round window membrane minimizes trauma to cochlear structures: A histologically controlled insertion study," *Acta Otolaryngol.*, vol. 124, pp. 807–812, 2004.
- [82] O. Adunka, W. Gstoettner, M. Hambek, M. H. Unkelbach, A. Radeloff, and J. Kiefer, "Preservation of basal inner ear structures in cochlear implantation," *ORL J. Otorhinolaryngol. Relat. Spec.*, vol. 66, pp. 306–312, 2004.
- [83] E. Lehnhardt, "Intracochlear placement of cochlear implant electrodes in soft surgery technique," *HNO*, vol. 41, pp. 356–359, 1993.
- [84] D. T. Lawson, S. Brill, R. D. Wolford, B. S. Wilson, and R. Schatzer, "Speech processors for auditory prostheses: Binaural cochlear implant findings – Summary of initial studies with eleven subjects," Neural Prosthesis Program, National Institutes of Health, Bethesda, MD, 9th Quart. Progress Rep., NIH project N01-DC-8-2105, 2000.
- [85] D. T. Lawson, R. D. Wolford, S. M. Brill, R. Schatzer, and B. S. Wilson, "Speech processors for auditory prostheses: Further studies regarding benefits of bilateral cochlear implants," Neural Prosthesis Program, National Institutes of Health, Bethesda, MD, 12th Quart. Progress Rep., NIH project N01-DC-8-2105, 2001.
- [86] B. J. Gantz *et al.*, "Binaural cochlear implants placed during the same operation," *Otol. Neurotol.*, vol. 23, pp. 169–180, 2002.
- [87] J. Müller, F. Schön, and J. Helms, "Speech understanding in quiet and noise in bilateral users of the MED-EL COMBI 40/40+ cochlear implant system," *Ear Hear.*, vol. 23, pp. 198–206, 2002.
- [88] F. Schön, J. Müller, and J. Helms, "Speech reception thresholds obtained in a symmetrical four-loudspeaker arrangement from bilateral users of Med-EL cochlear implants," *Otol. Neurotol.*, vol. 23, pp. 710–714, 2002.
- [89] R. S. Tyler *et al.*, "Three-month results with bilateral cochlear implants," *Ear Hear.*, vol. 23 (Suppl.), pp. 80S–89S, 2002.
- [90] R. van Hoesel, R. Ramsden, and M. O'Driscoll, "Sound-direction identification, interaural time delay discrimination, and speech intelligibility advantages in noise for a bilateral cochlear implant user," *Ear Hear.*, vol. 23, pp. 137–149, 2002.
- [91] R. S. Tyler, C. C. Dunn, S. A. Witt, and J. P. Preece, "Update on bilateral cochlear implantation," *Curr. Opin. Otolaryngol. Head Neck Surg.*, vol. 11, pp. 388–393, 2003.
- [92] R. J. van Hoesel and R. S. Tyler, "Speech perception, localization, and lateralization with bilateral cochlear implants," *J. Acoust. Soc. Amer.*, vol. 113, pp. 1617–1630, 2003.
- [93] R. Laszig *et al.*, "Benefits of bilateral electrical stimulation with the Nucleus cochlear implant in adults: 6-month postoperative results," *Otol. Neurotol.*, vol. 25, pp. 958–968, 2004.
- [94] P. Schleich, P. Nopp, and P. D'Haese, "Head shadow, squelch, and summation effects in bilateral users of the MED-EL COMBI 40/40+ cochlear implant," *Ear Hear.*, vol. 25, pp. 197–204, 2004.
- [95] S. Das and C. A. Buchman, "Bilateral cochlear implantation: Current concepts," *Curr. Opin. Otolaryngol. Head Neck Surg.*, vol. 13, pp. 290–293, 2005.
- [96] R. Ramsden *et al.*, "Evaluation of bilaterally implanted adult subjects with the Nucleus 24 cochlear implant system," *Otol. Neurotol.*, vol. 26, pp. 988–998, 2005.
- [97] P. Senn, M. Kompis, M. Vischer, and R. Haeusler, "Minimum audible angle, just noticeable interaural differences and speech intelligibility with bilateral cochlear implants using clinical speech processors," *Audiol. Neurootol.*, vol. 10, pp. 342–352, 2005.
- [98] R. Y. Litovsky, P. M. Johnstone, and S. P. Godar, "Benefits of bilateral cochlear implants and/or hearing aids in children," *Int. J. Audiol.*, vol. 45, no. 1, pp. S78–S91, 2006.
- [99] R. Litovsky, A. Parkinson, J. Arcaroli, and C. Sammeth, "Simultaneous bilateral cochlear implantation in adults: A multicenter clinical study," *Ear Hear.*, vol. 27, pp. 714–731, 2006.
- [100] R. S. Tyler, C. C. Dunn, S. A. Witt, and W. G. Noble, "Speech perception and localization with adults with bilateral sequential cochlear implants," *Ear Hear.*, vol. 28 (Suppl.), pp. 86S–90S, 2007.
- [101] P. Nopp, P. Schleich, and P. D'Haese, "Sound localization in bilateral users of MED-EL COMBI 40/40+ cochlear implants," *Ear Hear.*, vol. 25, pp. 205–214, 2004.
- [102] B. U. Seeber, U. Baumann, and H. Fastl, "Localization ability with bimodal hearing aids and bilateral cochlear implants," *J. Acoust. Soc. Amer.*, vol. 116, pp. 1698–1709, 2004.
- [103] F. Schoen, J. Mueller, J. Helms, and P. Nopp, "Sound localization and sensitivity to interaural cues in bilateral users of the Med-EL COMBI 40/40+ cochlear implant system," *Otol. Neurotol.*, vol. 26, pp. 429–437, 2005.
- [104] C. A. Verschuur, M. E. Lutman, R. Ramsden, P. Greenham, and M. O'Driscoll, "Auditory localization abilities in bilateral cochlear implant recipients," *Otol. Neurotol.*, vol. 26, pp. 965–971, 2005.
- [105] A. C. Neuman, A. Haravon, N. Sislian, and S. B. Waltzman, "Sound-direction identification with bilateral cochlear implants," *Ear Hear.*, vol. 28, pp. 73–82, 2007.
- [106] B. S. Wilson, R. D. Wolford, D. T. Lawson, and R. Schatzer, "Speech Processors for auditory prostheses: Additional Perspectives on speech reception with combined electric and acoustic stimulation," Neural Prosthesis Program, National Institutes of Health, Bethesda, MD, 3rd Quart. Progress Rep., NIH project N01-DC-2-1002, 2002.

- [107] H. Skarżyński, A. Lorens, and A. Piotrowska, "A new method of partial deafness treatment," *Med. Sci. Monit.*, vol. 9, pp. CS20–CS24, 2003.
- [108] C. W. Turner, B. J. Gantz, C. Vidal, A. Behrens, and B. A. Henry, "Speech recognition in noise for cochlear implant listeners: Benefits of residual acoustic hearing," *J. Acoust. Soc. Amer.*, vol. 115, pp. 1729–1735, 2004.
- [109] Y. Y. Kong, G. S. Stickney, and F. G. Zeng, "Speech and melody recognition in binaurally combined acoustic and electric hearing," *J. Acoust. Soc. Amer.*, vol. 117, pp. 1351–1361, 2005.
- [110] C. J. James, B. Fraysse, O. Deguine, T. Lenarz, D. Mawman, A. Ramos, R. Ramsden, and O. Sterkers, "Combined electroacoustic stimulation in conventional candidates for cochlear implantation," *Audiol. Neurootol.*, vol. 11, no. 1, pp. 57–62, 2006.
- [111] M. F. Dorman, A. J. Spahr, P. C. Loizou, C. J. Dana, and J. S. Schmidt, "Acoustic simulations of combined electric and acoustic hearing (EAS)," *Ear Hear.*, vol. 26, pp. 371–380, 2005.
- [112] K. E. Gfeller, C. Olszewski, C. Turner, B. Gantz, and J. Oleson, "Music perception with cochlear implants and residual hearing," *Audiol. Neurootol.*, vol. 11, no. 1, pp. 12–15, 2006.
- [113] K. Gfeller, C. Turner, J. Oleson, X. Zhang, B. Gantz, R. Froman, and C. Olszewski, "Accuracy of cochlear implant recipients on pitch perception, melody recognition, and speech reception in noise," *Ear Hear.*, vol. 28, pp. 412–423, 2007.
- [114] M. K. Qin and A. J. Oxenham, "Effects of simulated cochlear-implant processing on speech reception in fluctuating maskers," *J. Acoust. Soc. Amer.*, vol. 114, pp. 446–454, 2003.
- [115] M. K. Qin and A. J. Oxenham, "Effects of introducing unprocessed low-frequency information on the reception of envelope-vocoder processed speech," *J. Acoust. Soc. Amer.*, vol. 119, pp. 2417–2426, 2006.
- [116] J. T. Rubinstein, B. S. Wilson, C. C. Finley, and P. J. Abbas, "Pseudospontaneous activity: Stochastic independence of auditory nerve fibers with electrical stimulation," *Hear. Res.*, vol. 127, pp. 108–118, 1999.
- [117] F. G. Zeng, K. Nie, G. S. Stickney, Y. Y. Kong, M. Vongphoe, A. Bhargava, C. Wei, and K. Cao, "Speech recognition with amplitude and frequency modulations," in *Proc. Natl. Acad. Sci., U. S. A.*, 2005, vol. 102, pp. 2293–2298.
- [118] B. S. Wilson, R. Schatzer, E. A. Lopez-Poveda, X. Sun, D. T. Lawson, and R. D. Wolford, "Two new directions in speech processor design for cochlear implants," *Ear Hear.*, vol. 26, pp. 73S–81S, 2005.
- [119] Z. M. Smith, B. Delgutte, and A. J. Oxenham, "Chimaeric sounds reveal dichotomies in auditory perception," *Nature*, vol. 416, pp. 87–90, 2002.
- [120] B. S. Wilson, R. Schatzer, and E. A. Lopez-Poveda, "Possibilities for a closer mimicking of normal auditory functions with cochlear implants," in *Cochlear Implants*, S. B. Waltzman and J. T. Roland, Jr., Eds., 2nd ed. New York: Thieme Medical Publishers, 2006, pp. 48–56.
- [121] D. T. Lawson *et al.*, "Bilateral cochlear implants controlled by a single speech processor," *Amer. J. Otol.*, vol. 19, pp. 758–761, 1998.
- [122] B. A. Linkenhoker and E. I. Knudsen, "Incremental training increases the plasticity of the auditory space map in adult barn owls," *Nature*, vol. 419, pp. 293–296, 2002.
- [123] E. Zrenner, "Will retinal implants restore vision?," *Science*, vol. 295, pp. 1022–1025, 2002.
- [124] M. E. Brelén, F. Duret, B. Gérard, J. Delbeke, and C. Veraart, "Creating a meaningful visual perception in blind volunteers by optic nerve stimulation," *J. Neural Eng.*, vol. 2, pp. S22–S28, 2005.
- [125] E. Fernández, F. Pelayo, S. Romero, M. Bongard, C. Marin, A. Alfaro, and L. Merabet, "Development of a cortical visual neuroprosthesis for the blind: The relevance of neuroplasticity," *J. Neural Eng.*, vol. 2, pp. R1–R12, 2005.
- [126] L. B. Merabet, J. F. Rizzo, A. Amedi, D. C. Somers, and A. Pascual-Leone, "What blindness can tell us about seeing again: Merging neuroplasticity and neuroprostheses," *Nat. Rev. Neurosci.*, vol. 6, pp. 71–77, 2005.
- [127] D. Palanker, A. Vankov, P. Huie, and S. Baccus, "Design of a high-resolution optoelectronic retinal prosthesis," *J. Neural Eng.*, vol. 2, pp. S105–S120, 2005.
- [128] J. D. Weiland, W. T. Liu, and M. S. Humayun, "Retinal prosthesis," *Annu. Rev. Biomed. Eng.*, vol. 7, pp. 361–401, 2005.
- [129] M. Javaheri, D. S. Hahn, R. R. Laxhanpal, J. D. Weiland, and M. S. Humayun, "Retinal prostheses for the blind," *Ann. Acad. Med. Singapore*, vol. 35, pp. 137–144, 2006.
- [130] I. Wickelgren, "A vision for the blind," *Science*, vol. 312, pp. 1124–1126, 2006.
- [131] E. D. Cohen, "Prosthetic interfaces with the visual system: Biological issues," *J. Neural Eng.*, vol. 4, pp. R14–R31, 2007.
- [132] L. E. Hallum, G. Dagnelie, G. J. Suaning, and N. H. Lovell, "Simulating auditory and visual sensorineural prostheses: A comparative review," *J. Neural Eng.*, vol. 4, pp. S58–S71, 2007.
- [133] P. C. Hessburg and J. F. Rizzo, III, "The eye and the chip. World congress on artificial vision 2006," *J. Neural Eng.*, vol. 4, no. 1, 2007.
- [134] J. R. Hetling and M. S. Baig-Silva, "Neural prostheses for vision: Designing a functional interface with retinal neurons," *Neurol. Res.*, vol. 26, pp. 21–34, 2004.
- [135] N. P. Cottaris and S. D. Elfar, "How the retinal network reacts to epiretinal stimulation to form the prosthetic visual input to the cortex," *J. Neural Eng.*, vol. 2, pp. S74–S90, 2005.
- [136] M. A. Schiefer and W. M. Grill, "Sites of neuronal excitation by epiretinal electrical stimulation," *IEEE Trans. Neural Syst. Rehabil. Eng.*, vol. 14, pp. 5–13, 2006.
- [137] S. Shah, A. Hines, D. Zhou, R. J. Greenberg, M. S. Humayun, and J. D. Weiland, "Electrical properties of retinal-electrode interface," *J. Neural Eng.*, vol. 4, pp. S24–S29, 2007.
- [138] G. E. Loeb, C. L. Byers, S. J. Rebscher, D. E. Casey, M. M. Fong, R. A. Schindler, R. F. Gray, and M. M. Merzenich, "Design and fabrication of an experimental cochlear prosthesis," *Med. Biol. Eng. Comput.*, vol. 21, pp. 241–254, 1983.



Blake S. Wilson (M'80–SM'06) recently retired from RTI International following 33 years of continuous service and has become its first Emeritus Senior Fellow. He also is an Adjunct Professor at the Duke University Medical Center; the Chief Strategy Advisor for Med El GmbH of Innsbruck, Austria; and the Overseas Expert for a large project at the International Center of Hearing and Speech in Kajetany (near Warsaw), Poland, to improve treatments of hearing loss. These are all ongoing positions. He is the inventor of most of the speech

processing strategies used with present-day cochlear implants, including the continuous interleaved sampling (CIS), spectral peak picking (e.g., "*n-of-m*"), and virtual channel strategies, among others. The CIS and *n-of-m* strategies, or direct descendants of them, are used as the default strategies for all three implant systems now in widespread use. One of his papers, in the journal *Nature*, alternates with one other paper as the most highly cited publication in the field of cochlear implants. He has served as the Principal Investigator for 24 projects, including 13 projects for the National Institutes of Health. He also served as the Director of the Center for Auditory Prosthesis Research at RTI from its inception and for many years thereafter, until he was appointed as one of RTI's first four Senior Fellows in 2002.

Prof. Wilson and his coworkers have been recognized by many awards and honors, most notably the 1996 Discover Award for Technological Innovation and the American Otological Society's President's Citation for "Major contributions to the restoration of hearing in profoundly deaf persons." He has been the Guest of Honor at ten international conferences, and has been a keynote or invited speaker at more than 130 others. He has served as the Chair for two large international conferences and as the Co-Chair for two others. Most recently, he received the 2007 Distinguished Alumnus Award from the Pratt School of Engineering at Duke.



Michael F. Dorman received the Ph.D. degree in experimental child and developmental psychology (Linguistics minor) from the University of Connecticut, Storrs, in 1971.

A Fellow of the Acoustical Society of America, he is currently a Professor in the Department of Speech and Hearing Science and the Program in Linguistics at Arizona State University. He is the author of over 100 publications in areas including speech perception by infants, adults, hearing-impaired listeners and listeners fit with cochlear implants, and also cortical lateralization of function and neural plasticity. His research has been supported by the National Institutes of Health since 1973.

Chapter 4

Signal Processing Strategies for Cochlear Implants

BLAKE S. WILSON AND MICHAEL F. DORMAN

INTRODUCTION

Three large steps were needed to produce the present-day cochlear implants (CIs): (1) the pioneering step to implant the first patients and to develop devices that were safe and had a life span of many years; (2) the development of devices that provided multiple sites of stimulation in the cochlea to take advantage of the tonotopic organization of the auditory system; and (3) the development of highly effective processing strategies that utilized the multiple sites of stimulation and supported for the first time high levels of speech recognition for most users of CIs. Findings from the now-classic “Bilger Study” in 1977¹—and from the 1988 and 1995 NIH Consensus Statements on Cochlear Implants^{2,3}—summarize the status of CIs at each of these steps. Principal conclusions from the Bilger study and the two consensus statements are presented in Table 4–1. As noted there, especially large gains in performance were obtained in step 3.

Today, most recipients of CIs can converse with ease in quiet acoustic environments and even using their cell phones.

The restoration of function possible with a present-day CI is remarkable and far surpasses that of any other neural prosthesis. The CI is now widely regarded as one of the major advances of modern medicine.

Despite this success, and despite further substantial gains in performance that have been achieved since the major step 3 in the list above, problems remain with CIs. Patients with the best results still do not hear as well as persons with normal hearing in all situations, such as speech presented in competition with noise or other talkers. Users of standard unilateral CIs do not have much access to music and other sounds that are more complex than speech. In addition and most importantly, a wide range of outcomes persists even with the current processing strategies and implant systems. That is, patients may score almost anywhere in the range of possible scores in tests of speech reception that are more difficult than high-context sentences presented in quiet conditions. Also, a small proportion of patients have low scores even for the relatively easy tests.

The primary aim of this chapter is to describe the designs of the processing strategies now in widespread use. In addition, speech reception and other data

Table 4–1. Major Indicators of Progress in the Development of Cochlear Implants

<i>Persons or Event</i>	<i>Year</i>	<i>Comment or Outcome</i>
Bilger et al	1977	“Although the subjects could not understand speech through their prostheses, they did score significantly higher on tests of lipreading and recognition of environmental sounds with their prostheses activated than without them.” (This was an NIH-funded study of all 13 implant patients in the United States at the time.)
First NIH Consensus Statement	1988	Suggested that multichannel implants were more likely to be effective than single-channel implants, and indicated that about 1 in 20 patients could carry out a normal conversation without lipreading. (The world population of implant recipients was about 3,000 in 1988.)
Second NIH Consensus Statement	1995	“A majority of those individuals with the latest speech processors for their implants will score above 80% correct on high-context sentences, even without visual cues.” (The number of implant recipients approximated 12,000 in 1995, and the number exceeded 220,000 in early 2011.)

are presented to indicate strengths and weaknesses of the present approaches. Possibilities for improvements in processing strategies also are presented. In broad terms, great progress has been made in the development of processing strategies for CIs, but at the same time considerable room remains for improvement.

PROCESSING STRATEGIES FOR UNILATERAL COCHLEAR IMPLANTS

All CI systems now in widespread use include multiple channels of sound processing and multiple sites of stimulation along the length of the cochlea. The aim of these systems is to mimic at least to

some extent the “place” or “tonotopic” representation of frequencies in the normal cochlea, that is, by stimulating electrodes near the basal end of the cochlea to indicate the presence of sound components at high frequencies and by stimulating electrodes closer to the apical end to indicate the presence of sound components at lower frequencies.

At present, the largest manufacturers of implant devices include Advanced Bionics Corp of Valencia, California, USA; Cochlear Ltd of Lane Cove, Australia; and MED-EL GmbH of Innsbruck, Austria. Together these three have more than 99% of market share for CIs.

The processing strategies used in conjunction with each of these devices are listed in Table 4–2. The strategies include the continuous interleaved sampling (CIS),⁴

Table 4–2. Processing Strategies in Current Widespread Use*

<i>Manufacturer</i>	<i>CIS</i>	<i>CIS+</i>	<i>HDCIS</i>	<i>n-of-m</i>	<i>FSP</i>	<i>ACE</i>	<i>SPEAK</i>	<i>HiRes</i>	<i>HiRes 120</i>
MED-EL GmbH	•	•	•	•	•				
Cochlear Ltd	•					•	•		
Advanced Bionics Corp	•							•	•

*Manufacturers are shown in the left column and the processing strategies used in their implant systems are shown in the remaining columns. The full names of the strategies are presented in the text.

CIS+,^{5,6} “high definition” CIS (HDCIS),^{6,7} *n-of-m*,⁸ advanced combination encoder (ACE),⁹ spectral peak (SPEAK),¹⁰ HiResolution (HiRes),¹¹ HiRes with the Fidelity 120 option (HiRes 120),^{12,13} and fine structure processing (FSP)¹⁴ strategies. As shown in Table 4–2, each manufacturer offers multiple strategies. Among these choices, FSP recently supplanted CIS+ or HDCIS as the default strategy for the MED-EL devices (CIS+ and HDCIS are implemented with different hardware “platforms,” as explained below); HiRes and HiRes 120 are each used frequently with the Advanced Bionics devices; and ACE is the default choice for the Cochlear Ltd devices.

In the remainder of this section, we describe the principal features of these various strategies. Further detailed (but in some cases somewhat less current) information about the strategies is presented in comprehensive reviews by Loizou,¹⁵ Wilson,^{16,17} Wilson and Dorman,¹⁸ and Zeng et al.¹⁹ These reviews also present information about prior strategies, potential new strategies on the horizon, and other parts of CI systems including the transcutaneous transmission link, the implanted receiver/stimulator, and the implanted electrode array. As emphasized in several of the reviews, all parts of the system are important and the processing strategy functions (or fails to function well) in the context of the other parts.

CIS, CIS+, HDCIS, AND HIRES

One of the simpler and most effective approaches for representing speech and other sounds with the present-day CIs is illustrated in Figure 4–1. This is the CIS strategy, which is used as a processing

option for all of the implant systems now in widespread use and is the basis for other strategies, as described later in this chapter.

The CIS strategy filters input sounds into bands of frequencies with a bank of bandpass filters. Envelope variations in the different bands are represented at corresponding electrodes in the cochlea with modulated trains of biphasic electrical pulses. The envelope signals may be extracted from the bandpass filters using a rectifier followed by a low-pass filter (or by other means; see below). The signals are compressed with a nonlinear mapping function prior to the modulation, to map the wide dynamic range of audible sounds in the environment (about 100 dB) into the much narrower dynamic range of electrically evoked hearing (stimulus levels needed for eliciting loud percepts with electrical pulses typically are only 10 dB higher than the levels needed for eliciting threshold percepts). The output of each bandpass channel is directed to a single electrode, with channels with low-to-high center frequencies assigned to apical-to-basal electrodes, to mimic at least the order, if not the precise locations, of frequency mapping in the normal cochlea. The pulse trains are interleaved in time, so that the pulses across channels and the associated electrodes are nonsimultaneous. This eliminates a principal component of electrode interaction, which otherwise would be produced by direct vector summation of the electric fields from different (simultaneously stimulated) electrodes. (Other interaction components are not eliminated with the interleaving, but those components are generally much lower in magnitude than the principal component that results from the summation of the electric fields.²⁰) The corner or “cutoff” frequency of the

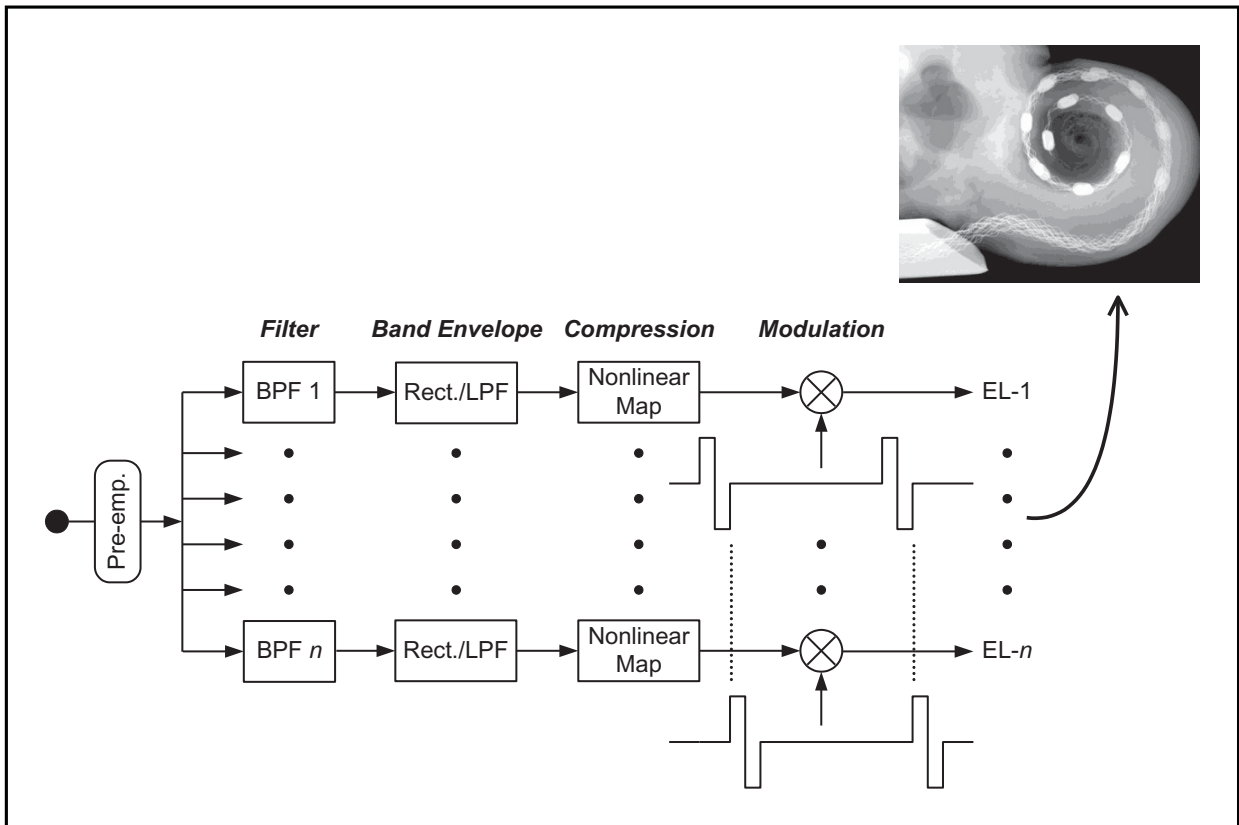

Figure 4–1. Block diagram of the continuous interleaved sampling (CIS) strategy. The input is indicated by the filled circle in the left-most part of the diagram. This input can be provided by a microphone or alternative sources. Following the input, a pre-emphasis filter (Pre-emp.) is used to attenuate strong components in speech below 1.2 kHz. This filter is followed by multiple channels of processing. Each channel includes stages of bandpass filtering (BPF), envelope detection, compression, and modulation. The envelope detectors generally use a full-wave or half-wave rectifier (Rect.) followed by a low-pass filter (LPF). A Hilbert Transform or a half-wave rectifier without the LPF also may be used. Carrier waveforms for two of the modulators are shown immediately below the two corresponding multiplier blocks (circles with an “X” mark within them). The outputs of the multipliers are directed to intracochlear electrodes (EL-1 to EL-n), via a transcutaneous link or a percutaneous connector. The inset shows an X-ray micrograph of the implanted cochlea, to which the outputs of the speech processor are directed. (Block diagram is adapted with permission from Wilson BS, Finley CC, Lawson DT, Wolford RD, Eddington DK, Rabinowitz WM. Better speech recognition with cochlear implants. *Nature*. 1991;352:236–238. Copyright 1991 Nature Publishing Group. Inset is reproduced with permission from Hüttenbrink KB, Zahnert T, Jolly C, Hofmann G. Movements of cochlear implant electrodes inside the cochlea during insertion: an x-ray microscopy study. *Otol Neurotol*. 2002;23:187–191. Copyright 2002 Lippincott Williams & Wilkins.)

low-pass filter in each envelope detector usually is set at 200 Hz or higher, so that the fundamental frequencies of voiced speech and other periodic sounds are represented in the modulation wave-

forms. The frequency range spanned by the bandpass filters typically begins at a frequency near or slightly above the cutoff frequency of the low-pass filters in the envelope detectors and ends at a

frequency near or somewhat above the highest frequencies included in speech. The idea is that extension of the lower boundary to lower frequencies is unnecessary and indeed possibly redundant, because those lower frequencies already are represented in the timing variations of the modulation waveforms. In one implementation of CIS, for example, 12 bandpass filters span the range from 250 to 8500 Hz, and the frequency boundaries (and the center frequencies) for the filters are distributed along a logarithmic scale, which mimics the logarithmic mapping of frequencies for most of the extent of the cochlear partition in normal hearing.

Pulse rates in CIS processors typically approximate or exceed 1000 pulses/s/electrode, for an adequate “sampling” of the highest frequencies in the modulation waveforms (a “four times” oversampling rule usually is applied, for example, for a 200-Hz cutoff frequency for the low-pass filters in the envelope detectors, a pulse rate of at least 800 pulses/s/electrode is used^{21–23}). CIS gets its name from the continuous sampling of the (compressed) envelope signals by rapidly presented pulses that are interleaved across electrodes. As many as 22 channels and associated stimulus sites have been used in CIS implementations to date, although speech reception scores generally do not increase with increases in the number of channels beyond 4 to 8, for the CIS and the other strategies in current widespread use.^{21,24–27}

The CIS+, HDCIS, and HiRes strategies are close variations of CIS. The CIS+ strategy is implemented in the MED-EL TEMPO+ processor, and the HDCIS strategy is implemented in the newer MED-EL OPUS 1 and OPUS 2 processors. Each of these strategies use a Hilbert transform to derive the envelope signals for each bandpass channel, instead of a rectifier

followed by a low-pass filter. The Hilbert transform may provide a better representation of the envelope variations in the band.⁵ In addition, the CIS+ and HDCIS strategies use bandpass filters with bell-shaped response patterns in the frequency domain, with substantial overlaps in responses between filters with adjacent center frequencies. These patterns differ from other implementations of CIS, in that other implementations use bandpass filters or Fast Fourier Transform (FFT) processing with relatively sharp cutoffs beyond the corner frequencies and with less overlap in responses between adjacent filters. The filters with the bell-shaped (or, more ideally, triangular shaped) frequency responses may produce a more uniform magnitude of the summed outputs of adjacent filters (and channels) when the frequency of a sinusoidal input is varied between the center frequencies of the filters. This in turn may provide a “smoother” and more salient representation of the intermediate frequencies compared with filters with sharp cutoffs and little overlap in responses between adjacent filters, as discussed in detail by Nobbe et al⁶ and as discussed further in the subsection below on the FSP strategy.

The HDCIS strategy differs from the CIS+ strategy in two respects. First, a refined design is used for the “front end” processing in the OPUS 1 and OPUS 2 hardware platforms, prior to the pre-emphasis filter in the block diagram of Figure 4–1. The design includes a substantially larger dynamic range of the amplifiers and other electronics in the input stages (providing an input dynamic range of 75 dB), and improvements in the (dual loop) automatic gain control for bringing the analog input signal into the best range for the subsequent digital processing. Thus, HDCIS may have a better input signal to “work with” compared to

CIS+ and most likely other implementations of CIS that use different hardware and therefore different input processing.

In addition, the OPUS 1 and OPUS 2 processors in conjunction with the implant systems that utilize them support aggregate rates of stimulation across electrodes up to 50,704 pulses/s, whereas the TEMPO+ processor and the earlier MED-EL COMBI 40+ system support rates up to 18,180 pulses/s. Thus, a further potential advantage of HDCIS over CIS+ is that HDCIS may use much higher stimulation rates.

HiRes is a CIS strategy that uses relatively high rates of stimulation and up to 16 processing channels and associated stimulus sites. For nonsimultaneous stimulation across 16 electrodes, the rate at each electrode can be as high as about 2900 pulses/s (producing an aggregate rate of about 46,400 pulses/s). In addition, the HiRes strategy uses the averaged output of a half-wave rectifier for envelope detection, instead of a rectifier and low-pass filter. The averaging operation produces a signal that is similar to the signal that would be produced with a low-pass filter. The HiRes strategy is identical in overall design compared with other implementations of CIS, but uses a somewhat different approach for envelope detection (which produces outputs that are highly similar to those produced with a half-wave rectifier followed by a low-pass filter) and can support in some instances a higher maximum rate of stimulation or a higher maximum number of channels and associated stimulus sites compared with the other implementations.

In general, implementations of CIS can vary widely among and even within implant systems. Some of the differences among implementations include: (1) the quality of the front-end processing; (2) the quality of the current source(s) in the implanted receiver/stimulator; (3) the range and res-

olution of the current outputs; (4) how the bandpass filtering is accomplished, either with FFT processing or with discrete filters; (5) the characteristics of the frequency response for each of the bandpass filters, for example, the spacing of the center frequencies for the filters and whether each filter has a rectangular or bell-shaped response; (6) the quality of the filter implementations as determined by the digital word length and other factors; (7) the way in which the envelope signals are derived; (8) the exact shape and range of the nonlinear mapping function; (9) the rate of stimulation at each electrode; (10) the number of channels and electrodes; (11) the order in which the electrodes are stimulated for each frame of stimulation; and (12) the positions of the electrodes within the cochlea, including the extent of the cochlear “tonotopic map” spanned by the electrodes, the interelectrode spacing, and the proximity of the electrodes to excitable tissue. Additional differences specific to comparisons of CIS as implemented in the Cochlear Ltd devices versus CIS as implemented with other devices are presented and discussed in Kiefer et al.⁹ Those authors emphasize that “as implementations (eg, for CIS) can vary considerably between different implant systems, the present results can be interpreted only in relation to the Nucleus CI 24M cochlear implant system.” (Kiefer et al compared the performances of the CIS, ACE, and SPEAK strategies, as implemented in Cochlear Ltd’s Nucleus CI 24M cochlear implant system.) Any of the aforementioned differences among implementations may affect performance. Thus, great caution should be used when interpreting results from various comparisons of CIS versus other (basic) strategies, or from comparisons of CIS or CIS-like strategies between different implant systems or even within systems but using

different parameter values or filtering approaches. Indeed, as Kiefer et al suggest, comparisons in some cases are not warranted at all because the implementations are so very different. Conservative approaches in comparing processing strategies for CIs are either to: (1) attend to comparisons between or among strategies implemented on the same hardware and holding everything constant beyond the strategy changes, or (2) choose the best results among the various implementations of each of the comparison strategies as representative of each strategy's true potential.

N-OF-M, ACE, AND SPEAK

The *n-of-m*, ACE, and SPEAK strategies derive stimulus pulses in the same way as the CIS strategies, that is, each channel of processing includes a bandpass filter, an envelope detector (or its equivalent), a nonlinear mapping function, and a multiplier (or modulator). In addition, all the strategies use nonsimultaneous pulses for the stimuli.

The principal difference between the *n-of-m*, ACE, and SPEAK strategies on the one hand, and the CIS strategies on the other hand, is that the former strategies each use a channel selection scheme in which the envelope signals are “scanned” prior to each frame of stimulation across the intracochlear electrodes, to identify the signals with the *n*-highest amplitudes from among *m* processing channels and their associated electrodes. The parameter *n* is fixed in the *n-of-m* and ACE strategies; that parameter can vary from frame to frame in the SPEAK strategy, depending on the level and spectral composition of the signal from the microphone or other input source. Stimulus rates typically approximate or exceed 1000 pulses/s/selected electrode in the *n-of-m* and ACE

strategies, and they approximate 250 pulses/s/selected electrode in the SPEAK strategy. (This choice was initially guided by the fact that the transcutaneous transmission link of the implant system initially used with SPEAK could not support rates of stimulation much higher than 250 pulses/s/electrode, for six electrodes in each stimulus frame.) The basic designs of the *n-of-m* and ACE strategies are identical, although the details of the implementations vary among implant systems. In addition, these strategies are quite similar to CIS except for the channel selection feature. The SPEAK strategy uses much lower rates of stimulation and an adaptive *n*, as noted above. Perhaps somewhat curiously, the strategy retains the 200 Hz cutoff frequency for the low-pass filters in the envelope detectors, even though the pulse rates at each of the selected electrodes approximate 250 pulses/s. This combination breaks the “4 times” rule and is likely to produce distortions in the representations of the modulation waveforms (see the final paragraph in this subsection for a discussion of speech recognition with the ACE and SPEAK strategies).

The channel selection or “spectral peak picking” scheme used in the *n-of-m*, ACE, and SPEAK strategies is designed in part to reduce the density of stimulation while still representing the most important aspects of the acoustic environment. The exclusion of channels with low-amplitude envelope signals for each frame of stimulation may reduce the overall level of masking or interference across electrodes and excitation regions in the cochlea. To the extent that the excluded channels do not contain significant information, such “unmasking” may improve the perception of the input signal by the patient. In addition, for positive speech-to-noise ratios (S/Ns), selection of the channels with the highest envelope signals in each frame

may emphasize the primary speech signal with respect to the noise.

A further potential advantage of the spectral peak picking strategies is that the reduced number of pulses per frame of stimulation (compared with the CIS and CIS-like strategies) may allow higher pulse rates, use of broader duration pulses, savings in power consumption (by holding the rate constant and thereby reducing the number of pulses presented per unit of time), or some combination of these possible attributes. The use of broader duration pulses may be especially helpful among these options as such use can: (1) reduce the upper limit of voltages needed in the implanted receiver/stimulator for effective stimulation and (2) increase the dynamic range of electrical stimulation from threshold to comfortably loud percepts.²⁸ The reduction in the upper limit of voltages needed for the receiver/stimulator can produce a further substantial savings in power consumption.

A possible problem with the *n-of-m*, ACE, and SPEAK strategies is that all of the perceptually important peaks in the short-term spectra of an input sound may not be represented. That is, two or more adjacent channels may be selected in any frame for an intense or broad peak, because the criterion for selection is the amplitudes of the envelope signals and not the shapes of the spectra, including the peak locations. Thus, for a fixed *n*, “clusters” of adjacent channels typically are selected for the most prominent peak or two peaks, and this clustering: (1) exhausts the opportunity for representing other peaks which also may be important and (2) may exacerbate deleterious masking effects with the selections of adjacent channels.

This clustering problem might be addressed by changing the selection algorithm, as has been recently suggested by Kals et al²⁸ and Nogueira et al,²⁹ among

others. In addition, application of techniques developed at the Bell Laboratories decades ago for the analogous “peak picking” vocoders (vocoder is an acronym for “voice coder”) might be helpful. (These techniques are reviewed in Flanagan’s classic book on “Speech Analysis, Synthesis and Perception,” published in 1972.³⁰) For example, one such technique involves a statistical analysis to identify the most significant peaks in the short-term spectra and then to transmit information about the frequency locations and amplitudes of those peaks only, to the exclusion of everything else including the amplitudes and positions of adjacent frequency locations. Quite possibly, selection of all perceptually important peaks, and a reduction or elimination of clustering for any single peak, could lead to improvements in performance for the *n-of-m* class of processing strategies for CIs, or could lead to a reduction in *n* (with its attendant advantages) while still maintaining performance that is on a par with standard implementations of *n-of-m*. Indeed, the latter has been achieved with the approaches suggested by Kals et al and Nogueira et al. Further progress is certainly possible.

In broad terms, the performance of the higher rate *n-of-m* strategies (called *n-of-m* in the MED-EL GmbH systems and ACE in the Cochlear Ltd systems) is on a par with or somewhat better than that of the CIS strategy, depending on the hardware implementations of the strategies.^{9,31,32} The best implementations of the *n-of-m* strategies on the one hand, and of the CIS strategy on the other hand, produce results that are statistically indistinguishable. In contrast, comparisons between SPEAK and ACE generally have indicated a clear superiority of the latter.^{9,33–35} Those strategies have been implemented using the same hardware

and choices for filter designs, so the difference must be due to some other factor or factors. Possible contributors to the lower performance with SPEAK include its relatively low rate of stimulation, the departure from the “four times” oversampling rule, the particular channel selection algorithm used with SPEAK, or some combination of these factors.

HIRES 120

The representation of frequencies may be coarse with the CIS, *n-of-m*, and the related strategies described in the two preceding subsections. In particular, those strategies present stimuli to a maximum of 22 intracochlear electrodes, whereas the number of stimulus sites in normal hearing approximates 3500, corresponding to the number of rows of sensory hair cells distributed along the length of the cochlea. In addition, the number of effective sites of stimulation with the present-day CIs is far below the maximum of 22 electrodes, as mentioned previously. The number of effective sites or channels also is far below the number of “equivalent rectangular bandwidths” (ERBs) in normal hearing,³⁶ which for the range of frequencies in speech is approximately 28 ERBs. (The number for the full range of audible frequencies is around 39 ERBs.) The ERBs correspond to independent channels of perception and processing in normal hearing for a wide variety of tasks including speech reception.

In an attempt to increase the number of effective sites of stimulation for CI users, and possibly the number of effective channels as well, Wilson et al developed a variation of CIS in the early 1990s that used simultaneous stimulation of pairs of adjacent electrodes to “shift” or “steer”

the electric fields to positions in between the positions produced with stimulation of either electrode alone.^{37–40} The idea was that the perceived pitches elicited by the simultaneous stimulation would be intermediate to the pitches elicited by stimulation of either electrode in the pair. Thus, with the inclusion of simultaneous stimulation of pairs of electrodes in the (otherwise) nonsimultaneous update sequence in a CIS-like strategy, additional discriminable pitches might be produced, beyond the number of electrodes in the implant. The intermediate sites of stimulation could be controlled with separate and additional channels of processing that also would include bandpass filtering, envelope detection, nonlinear mapping, and modulation, just like the channels in a conventional CIS strategy. These additional channels were called “virtual channels,” and the processors that used them were called “virtual channel interleaved sampling” (VCIS) processors. In one implementation of VCIS processors, simultaneous stimulation of adjacent pairs of electrodes was alternated with stimulation of a single electrode only. Thus, the nonsimultaneous update sequence for the implementation included stimulation of the apical-most electrode only, then simultaneous stimulation of the apical-most electrode and the electrode just basal to it, then stimulation of that latter electrode only, and so on until all of the electrodes in the array had been stimulated and all of the channels had been updated. This arrangement utilized almost twice as many processing channels compared with a conventional CIS strategy, for example, for six electrodes in the implant, 11 processing channels were used, with six of the channels controlling stimuli for the single electrodes with five of the channels controlling the five

pairs of electrodes receiving the simultaneous stimulation at different times in the update sequence. If the intermediate sites and associated pitches corresponded to separate channels of information, then the VCIS strategy might have the potential to support a higher number of effective channels than the CIS or other related strategies that used nonsimultaneous stimulation of electrodes only.

A series of diagrams illustrating the construction of virtual channels is presented in Figure 4–2. With virtual channels, adjacent electrodes may be stimulated simultaneously to shift the perceived pitch in any direction with respect to the percepts elicited with stimulation of either of the electrodes only. Results from studies with implant subjects indicate that pitch can be manipulated through various choices of simultaneous and single-electrode conditions.^{38,40} If, for instance, the apical-most electrode in an array of electrodes is stimulated alone (electrode 1, panel *a*), subjects have reported a low pitch. If the next electrode in the array is stimulated alone (electrode 2, panel *b*), a higher pitch is reported. An intermediate pitch can be produced for the great majority of subjects studied to date by stimulating the two electrodes together with identical, in-phase pulses (panel *c*). The pitch elicited by stimulation of a single electrode can also be shifted by presentation of an opposite-polarity pulse to a neighboring electrode. For example, a pitch lower than that elicited by stimulation of electrode 1 only can be produced by simultaneous presentation of a (generally smaller) pulse of opposite polarity at electrode 2 (panel *d*). (The stimulus paradigm illustrated in panel *d* and involving the presentation of pulses of opposite polarities at neighboring electrodes has been described as the “phantom electrode” technique in a recent

paper by Saoji and Litvak.⁴¹) The availability of pitches other than those elicited with stimulation of single electrodes only may provide additional discriminable sites along (and beyond) the length of the electrode array. Such additional sites may (or may not) support a higher number of effective information channels with implants, compared with stimulation that is restricted to single electrodes only.

The concept of virtual channels can be extended to include a quite-high number of sites and corresponding pitches, using different ratios of the currents delivered between simultaneously-stimulated electrodes. This possibility is illustrated in Figure 4–3, in which stimulus site 1 is produced by stimulation of electrode 1 only, stimulus site 2 by simultaneous stimulation of electrodes 1 and 2 with a pulse amplitude of 75% for electrode 1 and of 25% for electrode 2, and so on. The total number of sites and corresponding pitches that might be produced for a good subject in the illustrated case is 21, with six intracochlear electrodes. (A subject was tested with this arrangement and indeed obtained 21 discriminable pitches.⁴²) Other ratios of currents may produce additional pitches. Results from several recent studies have indicated that a high number of discriminable pitches can be created with this general approach, eg, Koch et al⁴³ found an average of 93 (range 8 to 466) discriminable pitches for a large population of subjects using either of two versions of the Advanced Bionics electrode array, both of which include 16 physical intracochlear electrodes spaced approximately 1 mm apart. (Some of the subjects did not perceive pitch differences even with stimulation of adjacent or more distant electrodes in isolation, producing a number of discriminable pitches that was less than the number of physical electrodes.)

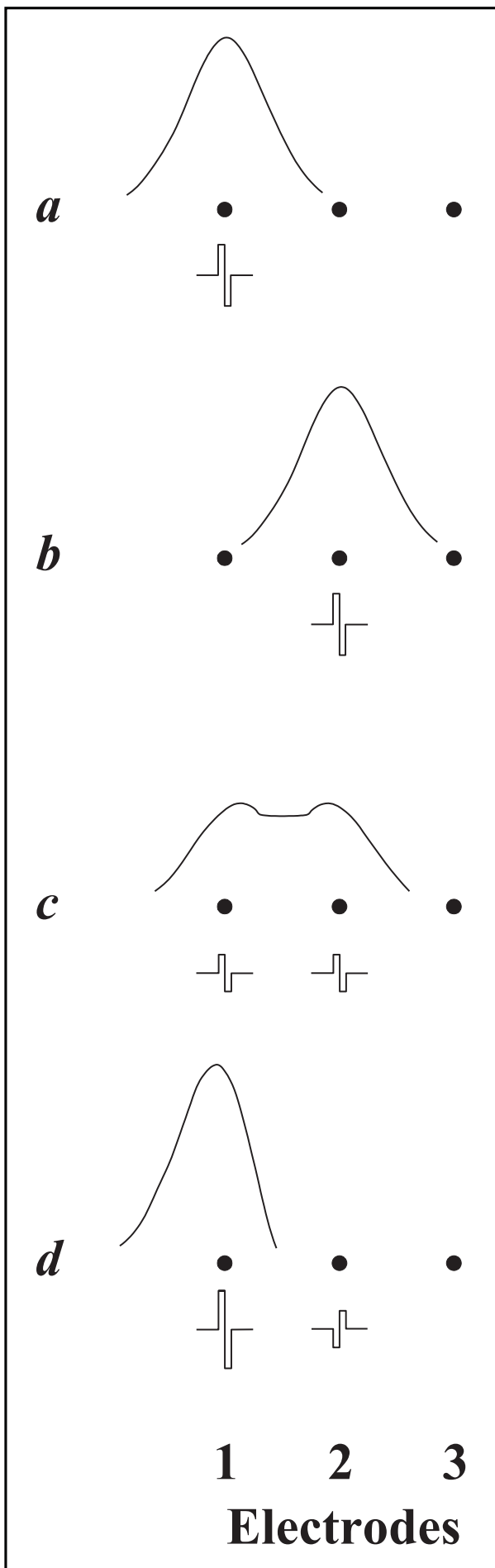

Figure 4–2. Schematic illustrations of neural responses for various conditions of stimulation with single and multiple electrodes. The top curve in each panel is a hypothetical sketch of the number of neural responses, as a function of position along length of cochlea for a given condition of stimulation. The condition is indicated by the pulse waveform(s) beneath one or more of the dots, which represent the positions of three adjacent intracochlear electrodes. These different conditions of stimulation elicit distinct pitches for implant patients, as described in the text. (Reproduced with permission from Wilson BS, Schatzer R, Lopez-Poveda EA. Possibilities for a closer mimicking of normal auditory functions with cochlear implants. In: Waltzman SB, Roland JT Jr, eds. Cochlear Implants. 2nd ed. New York, NY: Thieme; 2006:48–56.)

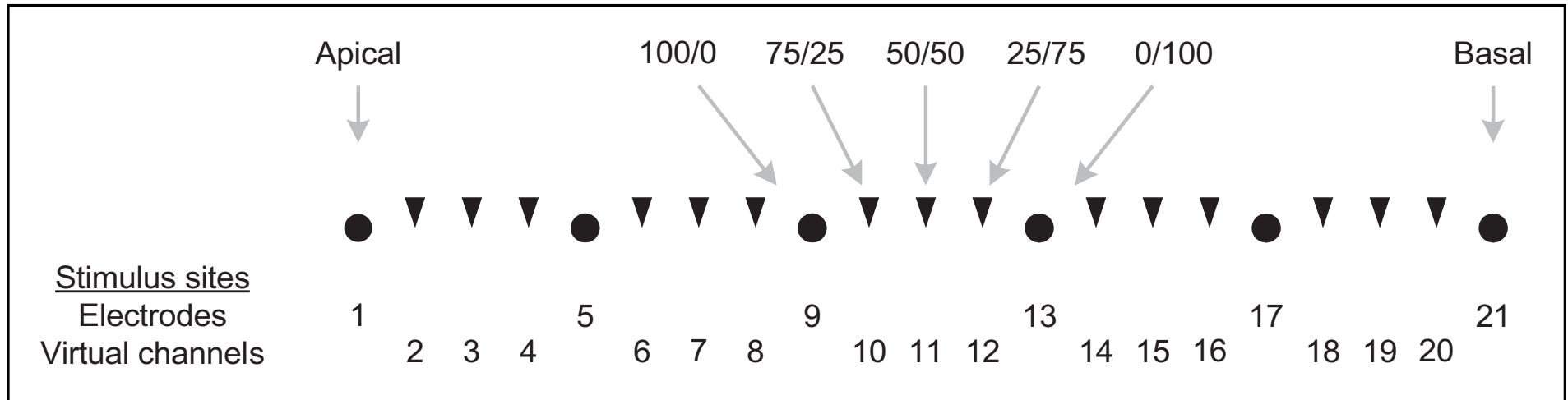

Figure 4–3. Diagram of stimulus sites used in virtual channel interleaved sampling (VCIS) processors and other similar processors that followed them. The filled circles represent sites of stimulation at each of six intracochlear electrodes. The inverted triangles represent additional sites produced with simultaneous stimulation of adjacent electrodes, at the indicated ratios of pulse amplitudes for the two electrodes. Thus, in this arrangement 21 sites may be produced, including the six electrodes and including the 15 “virtual” sites, between simultaneously stimulated electrodes. More electrodes may be used, and more sites may be formed between adjacent electrodes, for example, as in the 120 sites produced with the HiRes 120 strategy. Some patients are able to discriminate a high number of sites on the basis of pitch as described in the text. (Reproduced with permission from Wilson BS, Schatzer R, Lopez-Poveda EA. Possibilities for a closer mimicking of normal auditory functions with cochlear implants. In: Waltzman SB, Roland JT Jr, eds. Cochlear Implants. 2nd ed. New York, NY: Thieme; 2006:48–56.)

The original implementations of the VCIS strategy only used stimuli like those illustrated in panels *a* through *c* in Figure 4–2, that is, stimulation of single electrodes was alternated with simultaneous stimulation of pairs of electrodes using identical pulses for the pairs. The update sequence for an eleven-channel VCIS strategy is shown in Figure 4–4. As mentioned previously, this particular implementation of the VCIS strategy might produce nearly twice as many discriminable pitches and associated channels of information compared with a CIS strategy using the same number of intracochlear electrodes.

However, within-subjects comparisons between VCIS and CIS strategies using the same number of electrodes and other aspects of processing (eg, envelope detection, rate of stimulation, filter shapes, etc.) did not demonstrate a speech reception advantage of this implementation of VCIS.^{39,40} Some of the subjects commented that VCIS sounded “better,” or “fuller,” or “more natural” than CIS, but the scores for a variety of speech tests in quiet were not statistically different between the strategies for any of the tests. Possibly, tests with more subjects, or tests with the speech materials presented in competition with noise or other talkers, may have demonstrated a difference. In the administered tests, though, no difference was found. This was a disappointing outcome.

Later implementations of VCIS included more virtual sites of stimulation between the simultaneously stimulated electrodes,^{42,44,45} by using multiple ratios of currents for the simultaneously stimulated electrodes as illustrated in Figure 4–3. Those later implementations were first tested in 2003.⁴⁴ The results were not different in kind from the prior results, ie, scores with the VCIS processor were not significantly different from the scores

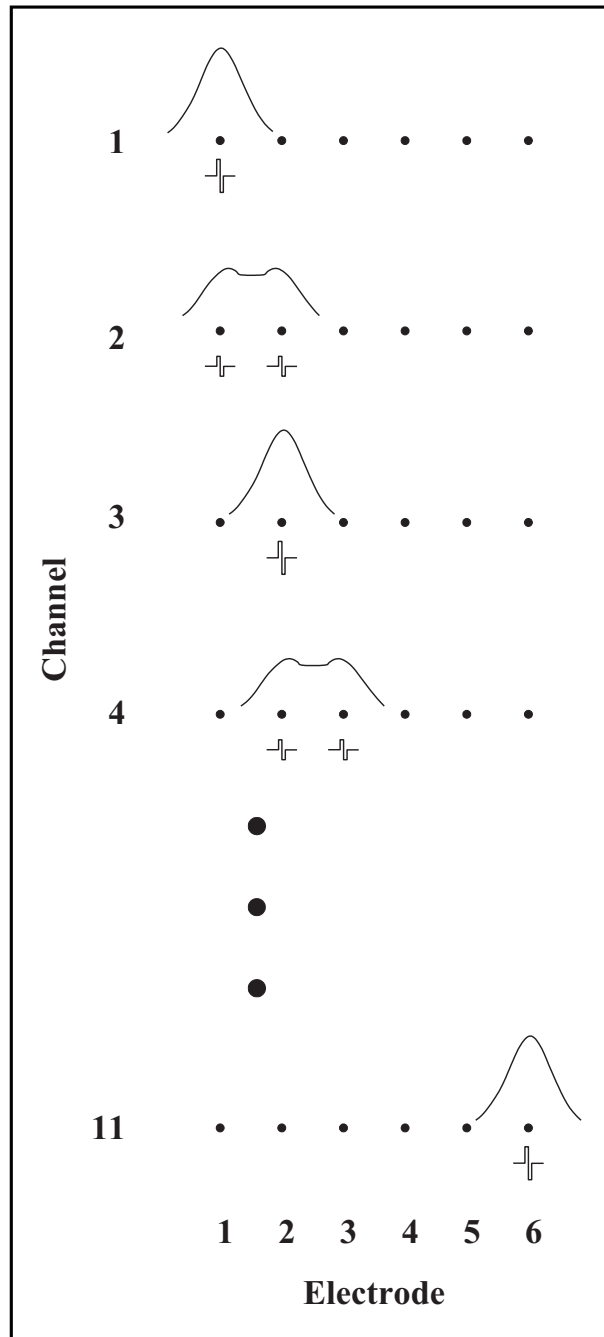

Figure 4–4. Construction of an 11-channel virtual channel interleaved sampling (VCIS) processor. The organization of the panels is the same as that in Figure 4–2. (Reproduced from Wilson BS, Lawson DT, Zerbi M. Speech processors for auditory prostheses: evaluation of VCIS processors. Sixth Quarterly Progress Report, NIH project N01-DC-2-2401. Bethesda, MD: Neural Prosthesis Program, National Institutes of Health; 1994; permission is not required for reproduction of figures from NIH Progress Reports.)

obtained with a control CIS processor using the same number of intracochlear electrodes.^{42,44} (In these later studies, the tests included identification of consonants presented in competition with speech-spectrum noise at the S/N of +5 dB.)

Most recently, another variation of the VCIS approach has been developed by the Advanced Bionics Corp. This is the HiRes 120 strategy, which “targets” sites for stimulation according to the frequency of the predominant component detected in each of 15 bandpass ranges.^{12,46–48} One among eight possible sites are selected for each range in each frame of stimulation across all of the ranges. In addition, an envelope signal is derived via a Hilbert transform for each bandpass range, as in implementations of the CIS, *n*-of-*m*, and other related strategies. Two adjacent electrodes are assigned to each bandpass range, and the electrodes are at corresponding tonotopic or frequency positions along the length of the cochlea, that is, the apical-most electrodes 1 and 2 are assigned to the bandpass range with the lowest center frequency, electrodes 2 and 3 are assigned to the range with the next highest center frequency, and so on, up to electrodes 15 and 16, which are assigned to the range with the highest center frequency. (The Advanced Bionics electrode array includes 16 intracochlear electrodes.) At the time of stimulation for each pair of electrodes, either the apical member of the pair is stimulated alone, or both electrodes are stimulated concurrently with one of seven possible ratios of currents for the electrodes. A predominant frequency in the lowest eighth of the frequency range invokes stimulation of the apical electrode only, and a higher predominant frequency in the range invokes stimulation of both electrodes with the current ratio and associ-

ated virtual site of stimulation that most closely corresponds to the predominant frequency. This procedure is repeated for each of the 15 bandpass ranges, involving 120 possible sites of stimulation (15 sites produced with stimulation of single electrodes plus 105 virtual sites produced with simultaneous stimulation of pairs of adjacent electrodes). The overall energy in each bandpass range (the envelope signal) is mapped onto the dynamic range of electrically evoked hearing using a nonlinear mapping function, as in the standard CIS strategy (see Fig 4–1). That mapped amplitude then is distributed to the two electrodes assigned to the range, according to the previously determined ratio of currents. For the one case among the eight in which only one electrode is stimulated, that electrode receives all of the current.

As in the prior implementations of the VCIS strategy, the stimuli for each of the bandpass ranges are sequenced across ranges, so that the pulse(s) for any one bandpass range do not overlap the pulse(s) for any other bandpass range. This sequencing eliminates direct summation of the electric fields produced by the stimuli for the different bandpass ranges.

The preceding description of the HiRes 120 strategy is only a brief overview. A detailed description is presented in section 2.2 of the excellent paper by Nogueira et al.⁴⁸

Comparisons between HiRes and HiRes 120 have been published by Brendel et al,⁴⁹ Donaldson et al,⁵⁰ Drennan et al,⁵¹ and Firszt et al.¹³ In addition, comparisons between HiRes and research versions of HiRes 120 have been published by Berenstein et al,⁵² Buechner et al,⁴⁶ and Nogueira et al.⁴⁸

In broad terms, the results from these studies are consistent with the results from the earlier comparisons between CIS and

VCIS, that is, in some cases preferences are expressed by the subjects in favor of HiRes 120, but the gains in speech reception are small or nonexistent. Indeed, when the HiRes and HiRes 120 strategies are implemented on the same hardware (either the “Platinum Sound Processor” or “Harmony” hardware), results from all of the studies cited in the preceding paragraph except the study by Firszt et al demonstrate a statistical equivalence between the two strategies; in particular, no significant differences were found across multiple tests for each of the studies, including tests of speech reception in quiet, speech reception in noise, and speech reception in competition with another talker or other talkers. The results from the study by First et al show small but statistically significant differences in favor of HiRes 120 for some of the administered tests including recognition of monosyllabic words in quiet and two tests of sentence recognition in noise. However, scores for the other administered tests are statistically indistinguishable. Those other tests included a third test of sentence recognition in noise and two tests of sentence recognition in quiet, with easy sentences in one of the tests and difficult sentences in the other of the tests.

Preference questionnaires were administered in all of the studies except the study by Drennan et al. The questionnaires included questions about speech quality in all cases, and the questionnaires included questions about music quality in the studies by Firszt et al and Nogueira et al. The mean of the preference measures for HiRes 120 and the Harmony hardware was significantly higher than the mean for HiRes in the study by Brendel et al. However, because the judgments were between HiRes 120 as implemented in the Harmony hardware, versus HiRes as implemented in the earlier “Auria” or “CII” hardware, the preference may have resulted from

the change in hardware as opposed to the change in strategy. (The Harmony hardware includes better front-end circuitry and processing compared with the Auria or CII hardware.) The measures from all of the remaining studies except the study by Firszt et al are statistically identical for the two strategies, that is, no preference was expressed for either of the strategies, either for speech quality^{46,48,50,52} or music quality.⁴⁸ The measures from the study by Firszt et al indicated a significant preference for HiRes 120 for music quality. (The music ratings for HiRes 120 were about 10 percentage points higher than the ratings for HiRes.) However, the measures for speech quality were not significantly different for the two strategies.

The great preponderance of the results reported to date indicates that the HiRes and HiRes 120 strategies are equivalent in terms of speech reception performance. Results from some of the tests in one among the seven studies conducted to date have indicated a small advantage of HiRes 120. However, results from other tests in that study, and all of the results from all of the other studies, indicate a statistical equivalence between the two strategies. Any differences if present between the strategies are small and apparently difficult to detect.

Although the concept of virtual channels is appealing, at least three plausible explanations have emerged as to why the various applications of the concept have failed to produce large gains in performance. The first explanation is that an apparent disconnect exists between the number of discriminable sites and the number of effective channels with implants. A patient can have a high number of discriminable sites when stimuli are delivered to different sites in isolation, one at a time and with long periods between sequential stimuli for the dif-

ferent sites. For example, many patients implanted with electrode arrays having 22 sites of stimulation can discriminate all 22 sites in ranking or same/different tasks with the stimuli presented in isolation as just described. However, no patient tested to date has more than about eight effective channels, including patients using the 22-electrode array and other arrays, and also including multiple processing strategies. The relatively low number of effective channels may be due to a combination of broad overlaps in the electric fields for the different electrodes and substantial masking across those electrode positions when dynamic (time-varying) stimuli are presented rapidly and continuously, as in a speech processor context. The masking could be at the periphery, or within the central auditory system, or both. In addition, the masking could arise even with nonsimultaneous stimulation across channels and their associated electrodes, as is used in all present-day CI systems.

Regardless of the mechanism, the number of effective channels may not be increased at all by simply increasing the number of discriminable sites. For example, a patient might have more than 400 discriminable sites using virtual channels,^{43,53} but this high number does not guarantee that the number of effective channels will be any higher than with a far lower number of discriminable sites. To date, none of the tested processing strategies, electrode arrays, or combinations of strategies and arrays, have produced an increase in the number of effective channels. The same may be true for virtual channel processors. (This hypothesis should be evaluated.)

The second explanation is that we may well have had virtual channels all along and just did not realize it until recently. In particular, McDermott and McKay⁵⁴ and others^{6,55} have shown that intermediate pitches also are produced

when closely spaced electrodes are stimulated in a rapid sequence, as compared with the pitches that are produced when each of the electrodes is stimulated separately. The pitch elicited with the rapid sequential stimulation of two electrodes in isolation varies according to the ratio of the currents delivered to the electrodes, just as with the intermediate pitches produced with simultaneous stimulation of the electrodes. Indeed, the numbers of discriminable pitches that can be produced with nonsimultaneous versus simultaneous stimulation are not significantly different.^{6,55} Thus, a fully nonsimultaneous strategy such as CIS may produce the same number of pitches (and discriminable sites) as a virtual channel strategy that stimulates pairs of electrodes simultaneously in the update sequence. If so, little or no difference in performance would be expected between the two types of strategy.

The third explanation has been offered by Drennan et al.⁵¹ They have suggested that any gain in the number of discriminable sites or pitches produced with HiRes 120 may be offset by the temporal “smearing” imposed by the FFT processing used in HiRes 120 but not HiRes. Thus, an increase in spatial or spectral resolution may be traded for a decrement in temporal resolution and the net result is zero or close to it.

Each of these explanations is highly plausible. Finding the correct explanation could lead to a major insight. At present, our knowledge is largely limited to the observation that the VCIS and HiRes 120 strategies have not produced large gains in the performance of CIs.

FSP

The term “fine structure” refers to small frequency differences in a signal or,

equivalently, to fine temporal variations in a signal. The representation of frequencies with CIs may be coarse, as discussed previously. Some additional detail may be provided with the virtual channel approaches, but the increment may be small if present at all compared with CIS and other strategies that present nonsimultaneous stimuli only. As mentioned in the preceding subsection, the numbers of discriminable frequencies produced with CIS and the related strategies may be just as high as the numbers produced with the virtual channel strategies involving simultaneous stimulation of pairs of electrodes.

Fine structure information has been shown to be important for music reception, speech reception in noise, word (or lexical) distinctions in tonal languages, and lateralization of sound sources in the horizontal plane.⁵⁶⁻⁵⁸ An increment in the amount or quality of this information that is presented and perceived with implants could be helpful for music and speech reception using either a unilateral CI or bilateral CIs, or for sound lateralization using bilateral CIs.

An alternative to the virtual channel approaches for presenting fine structure information is the FSP strategy recently introduced by MED-EL GmbH. This strategy also is a variation of CIS. The FSP strategy is designed to represent frequency variations within bandpass channels by initiating short groups of pulses at the positive zero crossings in the bandpass output(s) for the apical 1 to 4 channels. (If all four channels are used, the strategy is called the "FS4" strategy.) This temporal code may be more robust than the representation of temporal information with the envelope signals only,^{14,59} which is used in all other strategies reviewed thus far.

In addition, the range of frequencies spanned by the bandpass filters is

extended downward in the FSP strategy compared to the range used in standard implementations of the CIS strategy. A typical range for the FSP strategy is 70 to 8500 Hz, whereas a typical range for the CIS strategy is 250 to 8500 Hz. The range for the FSP strategy includes the fundamental frequencies for male, female, and child talkers, and the downward extension of the range compared to CIS allows the presentation of time-locked bursts of pulses at rates as low as about 70 bursts/s.

The combination in the FSP strategy of: (1) the downward extension of the frequency range spanned by the bandpass filters and (2) the presentation of time-locked stimuli at low rates might improve frequency discrimination at low frequencies compared to the CIS and the other strategies reviewed thus far. In fact, Krenmayr et al⁶⁰ recently evaluated this hypothesis in a comparison between the FSP and CIS strategies and found that the range of distinct pitches elicited with complex periodic sounds with varying fundamental frequencies is indeed extended to lower fundamental frequencies with the FSP strategy.

The temporal representation of fine structure information that is presented at one or more of the apical electrodes with the FSP strategy may be effective only up to frequencies of about 300 Hz for most implant patients and up to about 1000 Hz for exceptional patients. That is, pitch increases with the rate or frequency of stimulation at single electrodes for implant patients only up to these values.⁶¹ Higher rates or frequencies do not produce higher pitches. Instead, the pitch remains the same as at the asymptotic point, sometimes called the "pitch saturation limit," for implant patients. Thus, variations in the temporal patterns of stimulation provided by the FSP strategy

will be perceived only for the bandpass channels that include frequencies below the pitch saturation limit.

For this reason, the remaining (higher frequency) channels present conventional CIS stimuli. (The pitch saturation limit also guided the choice for the cutoff frequencies of the envelope detectors in the CIS and related strategies; that is, cutoff frequencies between 200 and 400 Hz restrict envelope variations to those upper limits, which do not generally exceed the pitch saturation limit.) The lowest or lower channels thus represent the “temporal fine structure” at the outputs of the corresponding bandpass filters by “marking” the positive zero crossings with stimulus presentations, and the higher channels represent the envelope variations with CIS stimuli. As mentioned above, those envelope variations also may convey fine-timing information up to the cutoff frequency of the envelope detectors. However, the salience of that representation may be less than the salience of the time-locked stimulus bursts presented to the apical electrode(s).

The FSP, CIS+, and HDCIS strategies all use bandpass filters with bell-shaped responses. As noted previously, this design may produce a smooth transition from one filter to the next when a sinusoidal input is “swept” between the center frequencies of the filters. Such smooth transitions may enhance the “channel balance” cue obtained with sequential stimulation of adjacent electrodes. In particular, frequencies in the input that are intermediate to the center frequencies of the bandpass filters will produce an output from both filters, and the ratio of the outputs from the filters will vary almost linearly as a function of the input frequency. Thus, a good approximation of the input frequency is represented in the ratio of the bandpass outputs, for all fre-

quencies between the center frequencies of the filters. Many different ratios may be perceived as different pitches, and thus the channel balance cue in conjunction with the bell-shaped responses for the filters may be another way to convey fine structure information to implant patients. (The situation for multiple components with different frequencies in the input to any two adjacent filters is considerably more complex.)

Alternative filter designs also may be effective in this regard, for example, the filters with the more rectangular responses that are used in other implementations of the CIS and other strategies. However, filters with the bell-shaped responses would be expected to maximize the transmission of fine structure information using the channel balance cues. (This hypothesis remains to be demonstrated.) The FSP, CIS+, and HDCIS strategies may convey fine structure information at relatively high frequencies with the channel balance cues produced with nonsimultaneous stimulation and with the bandpass filters with the bell-shaped responses. In addition, these strategies may convey information about the fundamental frequency through temporal variations in the modulation waveforms for the channels. The FSP strategy may augment this latter representation, and may convey further fine structure information at low frequencies (ie, frequencies below the pitch saturation limit), with the stimulus bursts that are time locked to the positive zero crossings in the bandpass outputs.

As in the CIS and other strategies, stimulus magnitudes for the apical channel(s) in the FSP strategy are determined with an envelope detector and nonlinear mapping function for each of the channels. Thus, channel balance cues are provided for all channels including the apical channels. Such cues may reinforce the

temporal code provided with the time-locked stimuli for the apical channels, or indeed may be as important or even more important in conveying the fine structure information at the low frequencies that are included in the apical channels.

We note that the FSP strategy is similar in design to a strategy described by Wilson et al in 1991,⁶² called the “peak picker/CIS” (PP/CIS) strategy. The principal difference between the FSP and PP/CIS strategies is that single pulses are presented at the peaks in the bandpass filter outputs in the PP/CIS strategy, whereas groups of pulses (including the possibility of a single pulse) are presented at the positive zero crossings in the FSP strategy. Two additional differences are that: (1) bandpass filters with bell-shaped responses are used in the FSP strategy, whereas filters with more-rectangular responses (Butterworth responses) are used in the PP/CIS strategy, and (2) the range of frequencies spanned by the bandpass filters is not extended downward in the PP/CIS strategy. (The FSP approach may possibly be better as a result of either or both of these latter two differences.) Subjects noted that the PP/CIS strategy sounded more natural and lower in overall pitch than the control CIS strategy, but the results from tests of open-set speech recognition in quiet were not statistically different between the two strategies.

Comparisons between the CIS+ and FSP strategies have been published by Arnoldner et al,⁵⁹ Riss et al,^{63,64} and Vermeire et al.⁶⁵ In addition, comparisons between HDCIS and FSP have been published by Riss et al,⁶⁶ and Magnusson.⁶⁷ Comparisons among CIS+, HDCIS, and FSP also have been published by Lorens et al⁷ and presented by Brill et al.⁶⁸ Furthermore, comparisons between research versions of CIS and FSP implemented with the same processor hardware have

been published by Schatzer et al.⁶⁹ All studies included measures of speech reception, and the studies of Arnoldner et al, Brill et al, Lorens et al, Magnusson, and Vermeire et al also included questionnaires for the subjects. Most of the questionnaires related to speech quality and strategy preferences. The questionnaires in the studies of Lorens et al and of Magnusson also related to judged differences in music quality between or among the tested strategies.

In broad terms, significant differences are found between CIS+ and FSP in the objective scores on speech tests (especially speech recognition in noise or in competition with other talkers) and in the responses to the questionnaires, in favor of FSP. These differences could be the result of the previously described differences between the TEMPO+ versus the OPUS 1 or OPUS 2 hardware; the use of the time-locked stimuli for the apical channel(s) in FSP; the difference between the frequency range spanned by the bandpass filters for CIS+ versus the range for FSP; or some combination of these factors.

In contrast, small or no differences are found between CIS and FSP when the two strategies are implemented with the same hardware. In particular: (1) the speech reception results reported by Brill et al did not favor HDCIS over FSP or vice versa, with both strategies implemented with the OPUS hardware; (2) the speech reception results reported by Magnusson et al did not show any statistically significant differences between HDCIS and FSP; (3) the speech reception results reported from the 2008 study by Riss et al comparing CIS and FSP with each using 2, 3, 5, 8, or 12 channels of processing and stimulation and with each implemented with the same hardware did not show any statistically significant differences between the strategies, including the stan-

dard 12-channel versions of the strategies; and (4) the speech and tone reception results reported by Schatzer et al did not show any statistically significant differences between research versions of the CIS and FSP strategies, as implemented using the same processor hardware and as tested with Cantonese materials and native Cantonese speakers. (Cantonese is a tone language whose reception might be significantly enhanced with a better representation of fine structure information at low frequencies, which is exactly what the FSP strategy is designed to provide.) Lorens et al found a small advantage of FSP over HDCIS for a speech reception measure in quiet but not for the same measure in noise. In addition, the responses to the questionnaires in that study indicated a preference for FSP versus HDCIS for listening to speech ($p = 0.048$) but no preference between the two strategies for listening to music. The preference for listening to speech was small and just attained statistical significance. The responses to the questionnaires in the study of Magnusson did not indicate a strategy preference for either speech or music reception.

The data to date indicate advantages of FSP over CIS+. In addition, the data indicate either a small advantage of FSP over HDCIS or a full equivalence between the two strategies. Most of the studies conducted thus far did not include a crossover design or other experimental controls for possible learning effects, which may have favored FSP in some of the comparisons. FSP is a promising approach, but more studies are needed to establish the magnitude of the benefit and whether the benefit may vary among different populations of patients or different listening situations, for example, speech in quiet versus speech in noise, or speech versus music reception. Such studies also

could help identify beneficial aspects of the hardware changes incorporated in the OPUS processors. Those changes could possibly support better results with a variety of implemented strategies, including the CIS and FSP strategies.

PERFORMANCE WITH UNILATERAL IMPLANTS

Representative findings from evaluations of the speech reception performance of unilateral CIs are presented in Figure 4–5, which shows scores for 55 users of the MED-EL COMBI 40 CI system and the CIS processing strategy as implemented with that system.⁷⁰ The subjects were postlingually deafened adults. Scores for recognition of the Hochmair-Schultz-Moser sentences are presented in Figure 4–5, panel *a*, and scores for recognition of the Freiburger monosyllabic words are presented in panel *b*. The sentences and words were presented in quiet without any interfering sounds. Results for five measurement intervals are shown, ranging from one month to 2 years following the initial fitting of the external speech processor. The solid line in each panel shows the mean of the individual scores. The fittings for most of the subjects included eight channels of processing and associated sites of stimulation and a pulse rate of about 1500/s/electrode. The fittings for some of the subjects included a lower number of channels and a proportionately higher rate. All fittings used the maximum overall pulse rate supported by the COMBI 40 implant, 12,120 pulses/s. The presented data are a superset of those reported in Helms et al⁷⁰ that include scores for additional subjects at various test intervals, as reported in Wilson.¹⁷

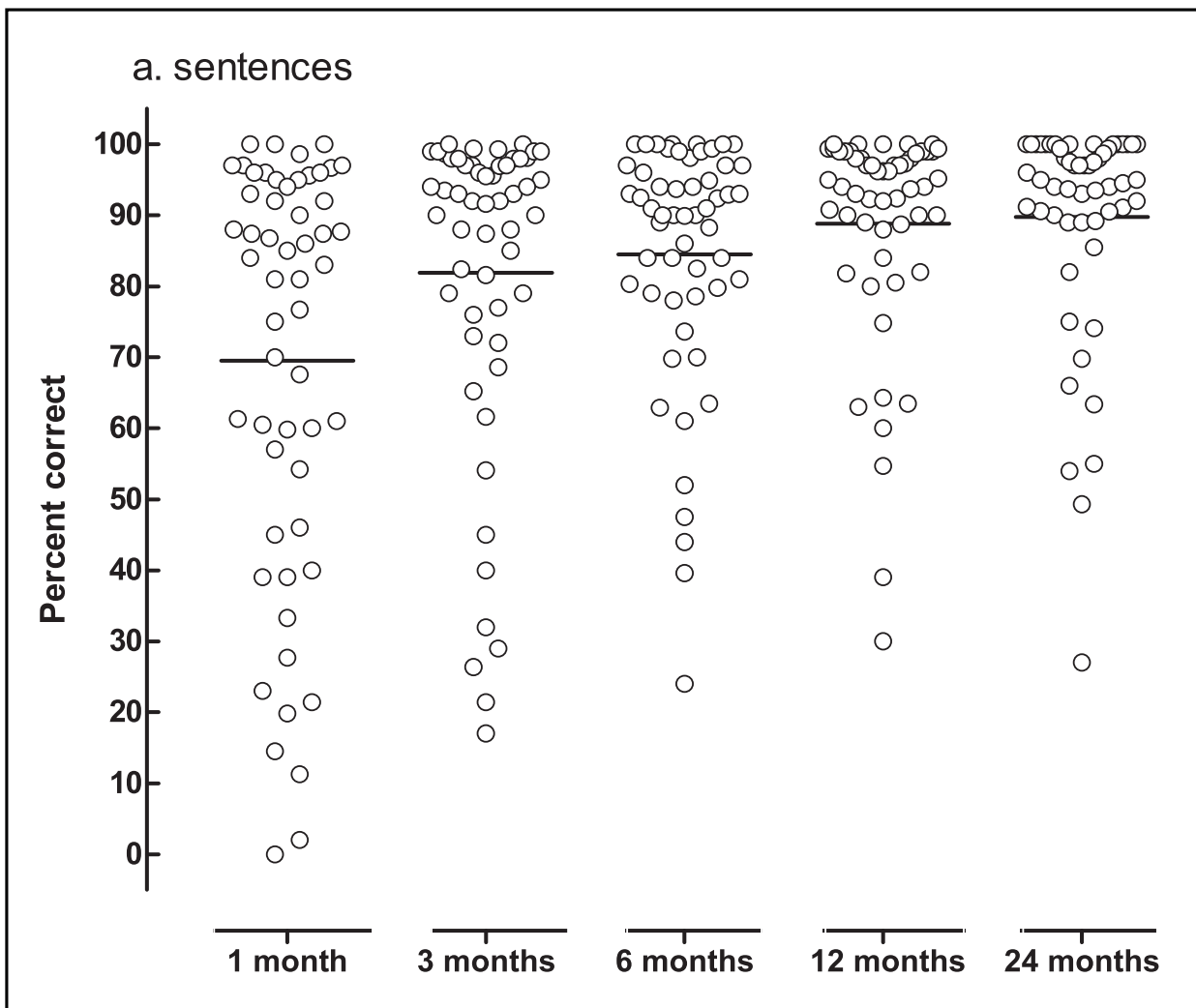

Figure 4–5. Percent correct scores for 55 users of the COMBI 40 cochlear implant and the continuous interleaved sampling (CIS) processing strategy. Scores for recognition of the Hochmair-Schultz-Moser sentences are presented in panel a, and scores for recognition of the Freiburger monosyllabic words are presented in panel b. Results for each of five test intervals following the initial fitting of the speech processor for each subject are shown. The horizontal line in each panel indicates the mean of the scores for that interval and test. (The great majority of the data are from Helms J, Müller J, Schön F, Moser L, Arnold W, et al. Evaluation of performance with the COMBI40 cochlear implant in adults: a multicentric clinical study. *ORL J Otorhinolaryngol Relat Spec.* 1997;59:23–35, with an update reported in Wilson BS. *Speech processing strategies.* In: Cooper HR, Craddock LC, eds. *Cochlear Implants: A Practical Guide.* 2nd ed. Hoboken, NJ: John Wiley & Sons; 2006:21–69. Figure is adapted from Dorman MF, Spahr AJ. *Speech perception by adults with multichannel cochlear implants.* In: Waltzman SB, Roland JT Jr, eds. *Cochlear Implants.* 2nd ed. New York, NY: Thieme Medical Publishers; 2006:193–204, and is used here with the permission of Thieme Medical Publishers.) continues

Figure 4–5 shows broad distributions of scores for both tests. However, ceiling effects are encountered for the sentence

test for many of the subjects, especially at the later test intervals. At 24 months, 46 of the 55 subjects score above 80% cor-

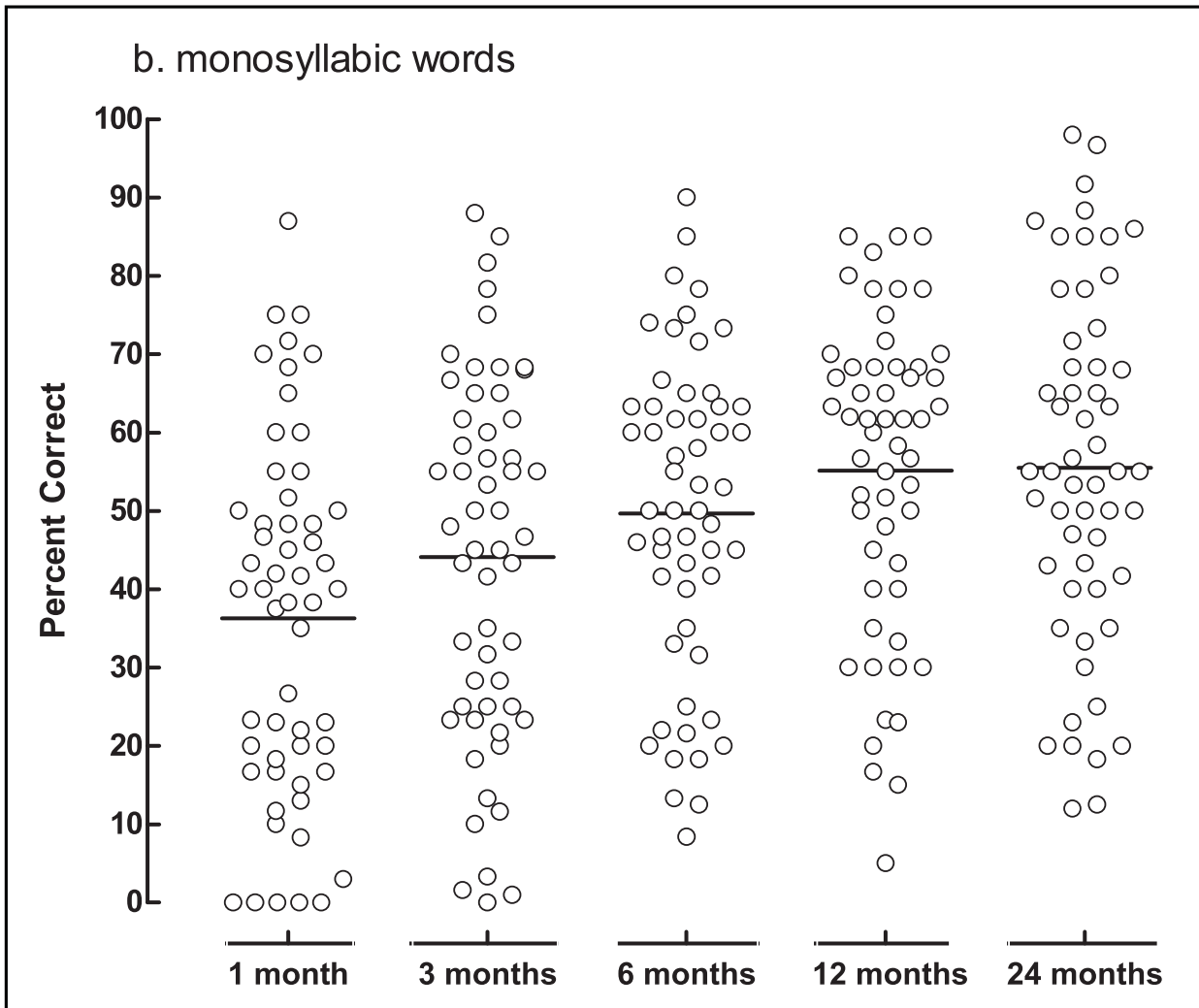

Figure 4–5. continued

rect, consistent with the conclusion from the 1995 NIH Consensus Statement on Cochlear Implants³ that is presented in Table 4–1. Scores for the recognition of the monosyllabic words are much more broadly distributed. For example, at the 24-month interval only nine of the 55 subjects have scores above 80% correct, and the distribution of scores from about 10% correct to nearly 100% correct is almost perfectly uniform.

An interesting aspect of the results presented in Figure 4–5 is the improvement in performance over time. This improvement is even easier to see in Figure 4–6, which shows the means and standard

errors of the means (SEMs) for these same data and for the additional intervals that were included for the sentence test. The means of the scores increase for both the sentence and word tests out to 12 months and then plateau thereafter. The means for the sentence test asymptote at about 90% correct, and the means for the word test asymptote at about 55% correct. The long-term course needed to attain the asymptotic performances indicates a role of the brain in determining outcomes with CIs. In particular, the time course far exceeds that of any possible changes at the periphery and must instead reflect plastic changes in brain organization and

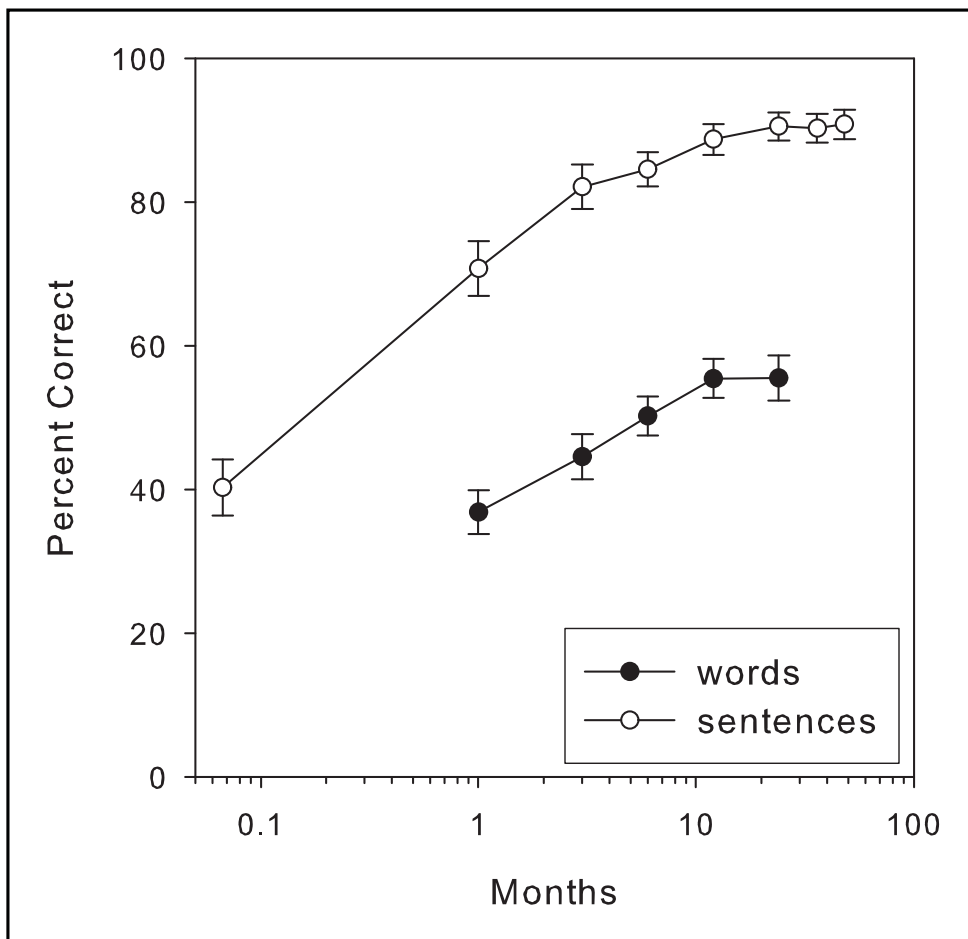

Figure 4-6. Means and standard errors of the means for the data and subjects in Figure 4-5. Note that the time scale along the x-axis is logarithmic. (Reproduced with permission from Wilson BS. *Speech processing strategies*. In: Cooper HR, Craddock LC, eds. *Cochlear Implants: A Practical Guide*. 2nd ed. Hoboken, NJ: John Wiley & Sons; 2006:21-69.)

function, as the brain “reconfigures” itself over the months to make progressively better use of the decidedly sparse and unnatural input from the periphery, as produced with the stimuli provided by the CI.

The results presented in Figures 4-5 and 4-6 typify performances with the best of the contemporary CI systems and unilateral stimulation. This fact is illustrated in Figure 4-7, which compares results from the Helms et al study, conducted in the mid-1990s and reported in 1997, with results from the subjects in Group 5 in the study of Krueger et

al,⁷¹ who received their unilateral CIs in the mid-2000s and whose results were reported in 2008. Group 5 included 310 subjects who used the newest devices of the time, including the CII or HiRes90K implant devices from Advanced Bionics Corp, the Freedom implant device from Cochlear Ltd, or the COMBI 40+ or Pulsar implant devices from MED-EL GmbH. The processing strategies implemented with these various devices included the CIS, CIS+, *n-of-m*, ACE, and HiRes strategies. Means of the scores for the recognition of the Freiburger monosyllabic

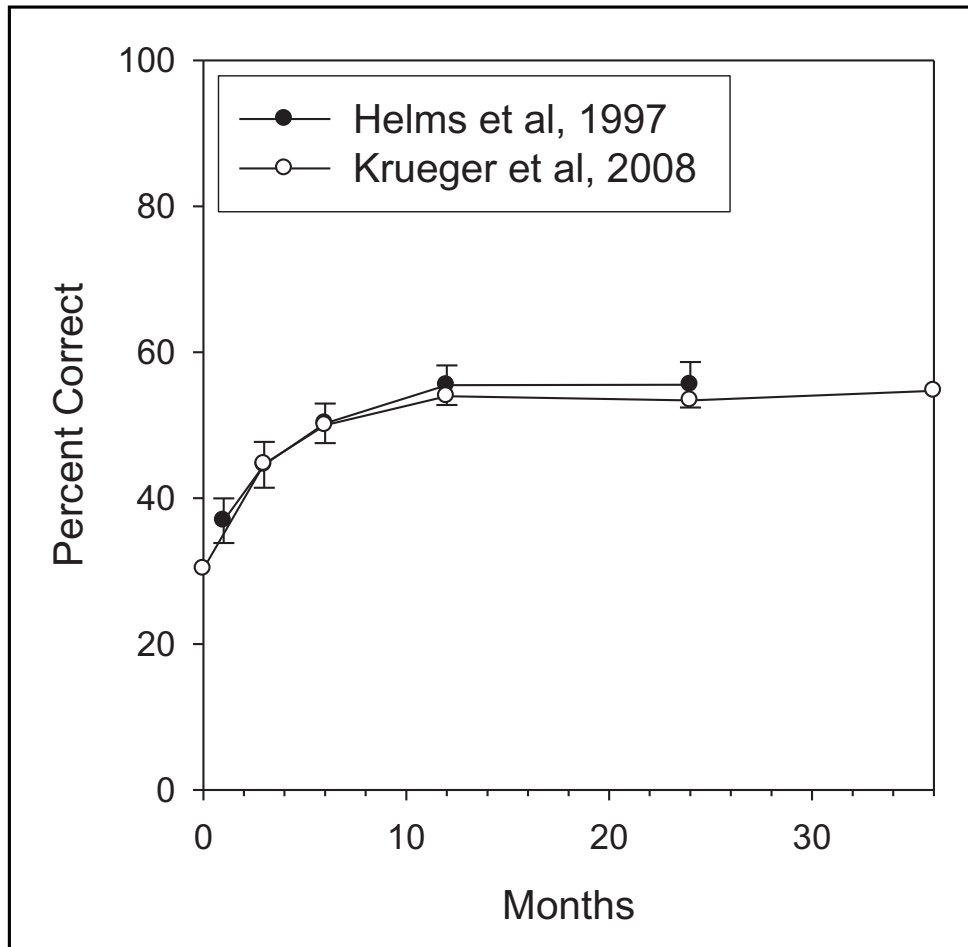

Figure 4-7. Recognition of monosyllabic words by cochlear implant subjects in the study of Helms et al (closed symbols) and in Group 5 in the study of Kruger et al (open symbols). The Freiburger test was used in both studies. The means of the scores are shown for both studies and the standard errors of the means (SEMs) are shown for the Helms et al study. The SEMs for the Krueger et al study are infinitesimally small due to the high number of subjects in Group 5 in the study (310 subjects). The x-axis indicates the time in months at and following the first fitting of the external sound processor for the subjects. (Data are from Helms J, Müller J, Schön F, Moser L, Arnold W, et al. Evaluation of performance with the COMBI40 cochlear implant in adults: a multicentric clinical study. *ORL J Otorhinolaryngol Relat Spec.* 1997;59:23–35, and from Krueger B, Joseph G, Rost U, Strauss-Schier A, Lenarz T, Buechner A. Performance groups in adult cochlear implant users: speech perception results from 1984 until today. *Otol Neurotol.* 2008;29:509–512.)

words in quiet are shown for the 55 subjects in the Helms et al study and the 310 subjects in Group 5 in the Krueger et al study. In addition, SEMs are shown for the subjects in the Helms et al study. (The

SEMs for the subjects in the Krueger et al study are much smaller due to the large number of subjects.)

The comparison presented in Figure 4-7 shows a complete overlap in

the results for unilateral CIs that were reported in 1997 and 2008. That is, the scores for the recognition of monosyllabic words are statistically indistinguishable between the groups of subjects at all test intervals out to 24 months following the initial fitting of the external speech processor. In addition, for this relatively difficult test, the scores and the means of the scores do not exhibit even the slightest hint of ceiling effects that might reduce the statistical power for detecting any differences between the groups.

This remarkable correspondence in the scores across the decade indicates that the large step forward with the introduction of CIS into widespread clinical use in the mid 1990s was not surpassed at least until the late 2000s. Indeed, as reviewed in the preceding major section on processing strategies for unilateral CIs, no processing strategy since the late 2000s has surpassed CIS and the related strategies with the possible exception of the FSP strategy for some tests. That latter possibility needs further evaluation, as also noted in the preceding section.

The results reviewed above generally apply to postlingually deafened patients. Results for prelingually deafened patients may be different, depending on the age of implantation. If the implant occurs at an early age, for example, 18 months or less, then the results for the prelingually deafened population are as good as the better outcomes for the postlingually deafened population.^{72,73} In contrast, implantations after the second or third birthday for the prelingual (or perilingually deafened) patients are associated with outcomes that are usually worse than those for the postlingual patients, and the odds for a good outcome are very poor for prelingually deafened persons implanted after 4 to 6 years of age.

STIMULATION IN ADDITION TO THAT PROVIDED WITH UNILATERAL IMPLANTS

The stimulation provided with unilateral CIs may be augmented by electrical stimulation on the contralateral side with another CI, or with acoustic stimulation for persons who have at least some residual hearing in either or both ears. Either mode of the additional stimulation can produce large improvements in speech reception, especially for speech presented in competition with noise or other talkers. For the cases in which both ears are stimulated, sound localization abilities also may be reinstated at least to some extent. Such abilities can restore a sense of fullness in auditory percepts and a sense of “living in a three-dimensional world,” as has been stated by many patients. The abilities also can confer further benefits in attending to a primary speaker or other source of sound in typical acoustic environments with multiple interfering sounds at other locations. The combination of electric plus acoustic stimulation (combined EAS) can improve the reception of music and tonal languages substantially, whether or not both ears are stimulated. These benefits of bilateral electrical stimulation and of combined EAS are described in detail in recent reviews by Dorman and Gifford⁷⁴ and by Wilson and Dorman.^{18,75}

Some of the aforementioned benefits are illustrated in Figure 4–8, which shows differences in percent correct scores between unilateral stimulation with one CI and either: (1) bilateral electrical stimulation with a CI on both sides or (2) combined EAS, with stimulation of one ear with a CI and the other ear with acoustic stimuli.

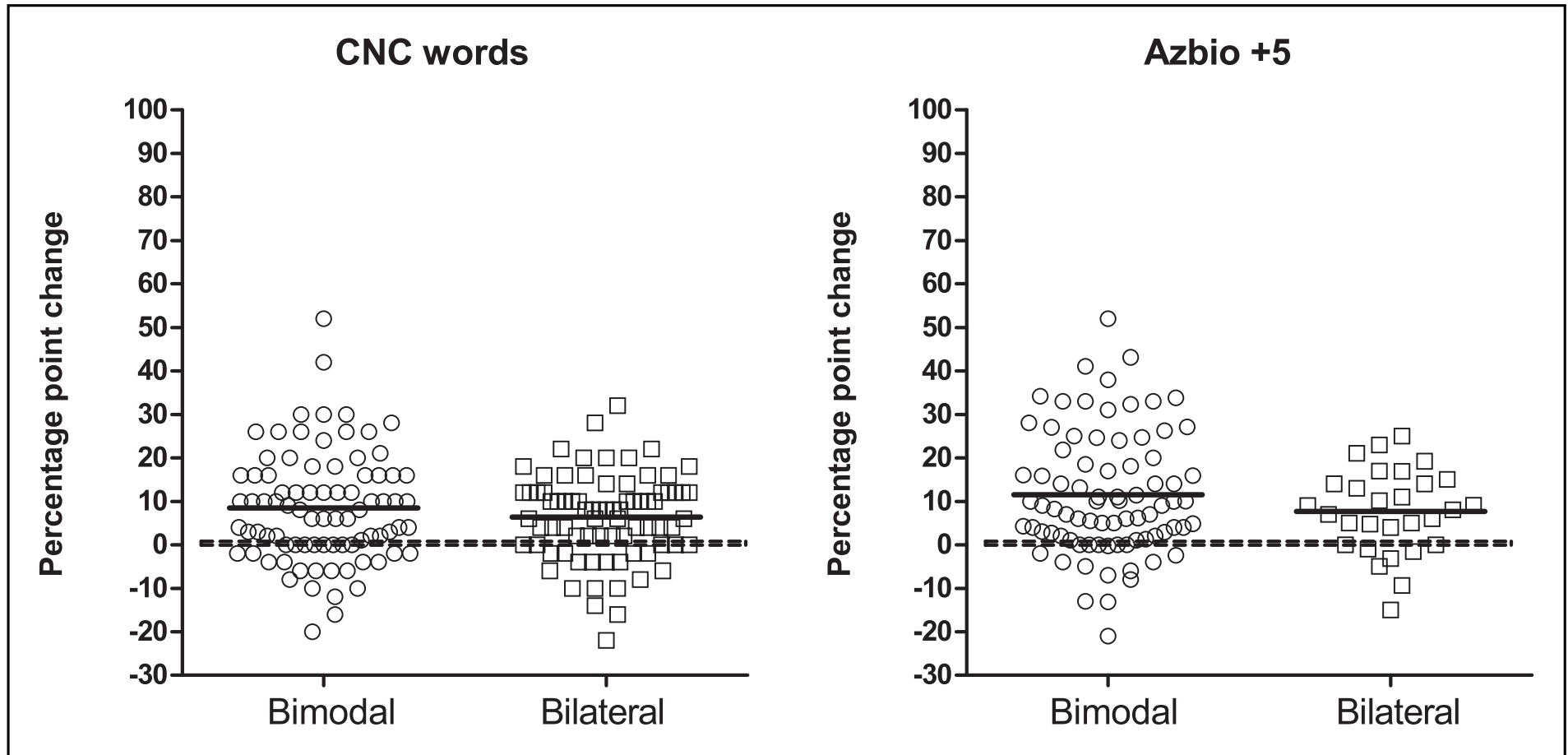

Figure 4–8. Differences in percent correct scores between unilateral stimulation with one cochlear implant (CI) and either: (1) bilateral electrical stimulation, with two CIs and with one on each side, or (2) combined electric and acoustic stimulation (bimodal stimulation), with stimulation of one ear with a CI and the other ear with acoustic stimuli. The tests included recognition of consonant-nucleus-consonant (CNC) monosyllabic words presented in quiet, and recognition of the Arizona Biomedical Institute (Azbio) sentences presented in competition with a four-talker speech babble noise at the speech-to-noise ratio of +5 dB. Additional details about the conditions of the tests and the sources of the data are presented in the text.

This latter condition is labeled “bimodal” in the figure. The comparisons for the bimodal subjects are between stimulation with the unilateral CI only versus stimulation of that CI plus acoustic stimulation of the contralateral ear. The comparisons for the bilateral subjects are between stimulation of the unilateral CI producing the better speech reception scores for each subject versus stimulation with both CIs. The bimodal subjects are from a cohort described in Dorman and Gifford, and the bilateral subjects are from participants in the clinical trials of bilateral implants in the United States. These latter subjects used either an Advanced Bionics Corp CI on both sides, a Cochlear Ltd CI on both sides, or a MED-EL GmbH CI on both sides. The tests included recognition of consonant-nucleus-consonant (CNC) monosyllabic words presented in quiet for all subjects in both groups of subjects, and recognition of the relatively difficult Arizona Biomedical Institute (Azbio) sentences⁷⁶ presented in competition with a four-talker speech babble noise at the S/N of +5 dB for subsets of the subjects. Recognition of the CNC words was measured with 83 bimodal subjects and 80 bilateral subjects. Recognition of the Azbio sentences in noise was measured with 80 bimodal subjects and 29 bilateral subjects. The scores presented in Figure 4–8 are referenced to the mean scores for the CI only for the bimodal subjects and the better of the two CIs for the bilateral subjects. Those mean scores for the bimodal subjects were 58 and 32% correct for the CNC word and Azbio sentence tests, respectively. The mean scores for the bilateral subjects were both 55% correct for the two tests.

The data presented in Figure 4–8 indicate that large gains in speech reception may be obtained with either intervention. That is, the numbers of subjects

whose scores are higher than the baseline for either test with either intervention far outweigh the numbers of subjects whose scores are lower than the baseline. In addition, the mean scores increase up to about 10 percentage points with the stimulation in addition to the unilateral CI for both tests and for both types of additional stimulation. Between the two types of additional stimulation, combined EAS (bimodal) may provide the possibility of larger gains for speech reception in noise than bilateral CIs. The overall improvements for either mode of additional stimulation are substantial.

Although the gains can be substantial, not all prospective patients will be able to take advantage of the possibilities offered by bilateral CIs or combined EAS. For example, national health care plans or third-party insurers do not always cover the additional cost of the second implant for bilateral CIs. In addition, some candidates for a CI do not have any useful residual hearing that could be stimulated effectively with the acoustic stimulation part of combined EAS. Thus, a need remains to improve the performance of unilateral CIs for many patients. That need also is evident in the remaining variability in outcomes even with bilateral CIs or combined EAS (see Fig 4–8). The scores with these interventions are higher on average than the scores obtained with unilateral CIs, but the results across patients are still highly variable and much room remains for improvements in the mean scores and most especially in the scores for individuals that are below the mean. A better contribution from each unilateral CI could exert a salutatory effect on the performance of bilateral CIs, and a better contribution from the CI could produce substantially better results with the combination of electric plus acoustic stimulation.

POSSIBILITIES FOR IMPROVEMENT

Fortunately, there are many promising possibilities for improvement in the design and performance of unilateral CIs. Some of the possibilities are described in two recent reviews by Wilson and Dorman,^{18,75} and include: (1) a closer mimicking of the intricate processing in the normal cochlea; (2) continued development of approaches to represent fine structure information with implants, including representations of the first several harmonics for periodic sounds, which are so very important for pitch and music perception; (3) an increase in the number of effective channels with implants, for example, with new electrode designs or placements, optical rather than electrical stimulation, or directed growth of neurites toward intracochlear electrodes as promoted by various neurotrophic drugs; (4) a “top down” or “cognitive neuroscience” approach to the design of CIs and other neural prostheses that takes differences in brain function among users into account; and (5) identifying the cause or causes of the apparent disconnect between the number of discriminable sites of stimulation versus the number of effective channels with implants, and then acting on that knowledge to bring the latter number closer to the former number. Of course, possibilities 3 and 5 may be related. Further detailed information about the “closer mimicking” and “top down” approaches to CI designs is presented in several recent papers by Wilson et al,^{42,45,77,78} and further detailed information about the importance of representing the harmonic structure of periodic sounds is presented in a seminal paper by Oxenham et al.⁷⁹ Realization of any

of the listed possibilities could produce another breakthrough, akin to the advent of multichannel processing and multiple sites of stimulation in the early 1980s, and akin to the advent of the CIS and related processing strategies in the late 1980s and early 1990s.

CONCLUDING REMARKS

We as a community have come a long way indeed in the development of CIs and processing strategies for them, but much room remains for further improvements. Fortunately, there are multiple promising possibilities for such improvements. Changes in processing strategies have produced large gains in performance in the past and may well do so in the future.

Acknowledgments. Parts of this chapter are drawn or adapted from prior publications, including Wilson and Dorman^{18,75,80} and Wilson et al.⁷⁸ Author BSW is a consultant for MED-EL GmbH of Innsbruck, Austria, and author MFD is a consultant for Advanced Bionics Corp of Valencia, California, USA. None of the statements in this chapter favor either of those companies or any other company.

REFERENCES

1. Bilger RC, Black FO, Hopkinson NT, et al. Evaluation of subjects presently fitted with implanted auditory prostheses. *Ann Otol Rhinol Laryngol.* 1977;86(suppl 38, no 3, pt 2):1–176.
2. National Institutes of Health. Cochlear implants. *NIH Consensus Statements.* 1988; 7(2):1–9. (This statement also is available

- in *Arch Otolaryngol Head Neck Surg*. 1988;115:31–36.)
3. National Institutes of Health. Cochlear implants in adults and children. *NIH Consensus Statements*. 1995;13(2):130. (This statement also is available in *JAMA*. 1995; 274:1955–1961.)
 4. Wilson BS, Finley CC, Lawson DT, Wolford RD, Eddington DK, Rabinowitz WM. Better speech recognition with cochlear implants. *Nature*. 1991;352:236–238.
 5. Helms J, Müller J, Schön F, Winkler F, Moser L, et al. Comparison of the TEMPO+ ear-level speech processor and the CIS PRO+ body-worn processor in adult MED-EL cochlear implant users. *ORL J Otorhinolaryngol Relat Spec*. 2001;63:31–40.
 6. Nobbe A, Schleich P, Zierhofer C, Nopp P. Frequency discrimination with sequential or simultaneous stimulation in MED-EL cochlear implants. *Acta Otolaryngol*. 2007;127:1266–1272.
 7. Lorens A, Zgoda M, Obrycka A, Skarzynski H. Fine structure processing improves speech perception as well as objective and subjective benefits in pediatric MED-EL COMBI 40+ users. *Int J Pediatr Otorhinolaryngol*. 2010;74:1372–1378.
 8. Wilson BS, Finley CC, Farmer JC Jr, et al. Comparative studies of speech processing strategies for cochlear implants. *Laryngoscope*. 1988;98:1069–1077.
 9. Kiefer J, Hohl S, Sturzebecher E, Pfenigdorff T, Gstoettner W. Comparison of speech recognition with different speech coding strategies (SPEAK, CIS, and ACE) and their relationship to telemetry measures of compound action potentials in the Nucleus CI 24M cochlear implant system. *Audiology*. 2001;40:32–42.
 10. Skinner MW, Clark GM, Whitford LA, et al. Evaluation of a new spectral peak (SPEAK) coding strategy for the Nucleus 22 channel cochlear implant system. *Am J Otol*. 1994;15(suppl 2):15–27.
 11. Koch DB, Osberger MJ, Segal P, Kessler D. HiResolution and conventional sound processing in the HiResolution Bionic Ear: using appropriate outcome measures to assess speech-recognition ability. *Audiol Neurootol*. 2004;9:214–223.
 12. Trautwein, P. HiRes with Fidelity™ 120 sound processing: implementing active current steering for increased spectral resolution in CII BionicEar® and HiRes90K users. Advanced Bionics Corporation, Valencia, CA, 2006. (This report is presented at http://www.bionicear.com/userfiles/File/HiRes_Fidelity120_Sound_Processing.pdf and was retrieved on April 19, 2011.)
 13. Firszt JB, Holden LK, Reeder RM, Skinner MW. Speech recognition in cochlear implant recipients: comparison of standard HiRes and HiRes 120 sound processing. *Otol Neurotol*. 2009;30:146–152.
 14. Hochmair I, Nopp P, Jolly C, Schmidt M, Schösser H, Garnham C, Anderson I. MED-EL cochlear implants: state of the art and a glimpse into the future. *Trends Amplif*. 2006;10:201–219.
 15. Loizou P. Speech processing in vocoder-centric cochlear implants. In: Moller A, ed. *Cochlear and Brainstem Implants*. Basel: Karger; 2006:109–143. (An alternative citation for this reference is *Adv Otorhinolaryngol*. 2006;64:109–143.)
 16. Wilson BS. Engineering design of cochlear implant systems. In: Zeng F-G, Popper AN, Fay RR, eds. *Auditory Prostheses: Cochlear Implants and Beyond*. New York, NY: Springer-Verlag; 2004:14–52.
 17. Wilson BS. Speech processing strategies. In: Cooper HR, Craddock LC, eds. *Cochlear Implants: A Practical Guide*. 2nd ed. Hoboken, NJ: John Wiley & Sons; 2006:21–69.
 18. Wilson BS, Dorman MF. The design of cochlear implants. In: Niparko JK, Kirk KI, Mellon NK, Robbins AM, Tucci DL, Wilson BS, eds. *Cochlear Implants: Principles and Practices*. 2nd ed. Philadelphia, PA: Lippincott Williams & Wilkins; 2009:95–135.
 19. Zeng FG, Rebscher S, Harrison WV, Sun X, Feng H. Cochlear implants: system design, integration and evaluation. *IEEE Rev Biomed Eng*. 2008;1:115–142.

20. Favre E, Pelizzone M. Channel interactions in patients using the Ineraid multi-channel cochlear implant. *Hear Res.* 1993; 66:150–156.
21. Wilson BS. The future of cochlear implants. *Brit J Audiol.* 1997;31:205–225.
22. Busby PA, Tong YC, Clark GM. The perception of temporal modulations by cochlear implant patients. *J Acoust Soc Am.* 1993; 94:124–131.
23. Wilson BS, Finley CC, Lawson DT, Zerbi M. Temporal representations with cochlear implants. *Am J Otol.* 1997;18:S30–S34.
24. Fishman KE, Shannon RV, Slattery WH. Speech recognition as a function of the number of electrodes used in the SPEAK cochlear implant speech processor. *J Speech Lang Hear Res.* 1997;40:1201–1215.
25. Friesen LM, Shannon RV, Baskent D, Wang X. Speech recognition in noise as a function of the number of spectral channels: comparison of acoustic hearing and cochlear implants. *J Acoust Soc Am.* 2001; 110:1150–1163.
26. Garnham C, O’Driscoll M, Ramsden R, Saeed S. Speech understanding in noise with a Med-El COMBI 40+ cochlear implant using reduced channel sets. *Ear Hear.* 2002;23:540–552.
27. Dorman MF, Spahr AJ. Speech perception by adults with multichannel cochlear implants. In: Waltzman SB, Roland JT Jr, eds. *Cochlear Implants*. 2nd ed. New York, NY: Thieme Medical Publishers; 2006:193–204.
28. Kals M, Schatzer R, Krenmayr A, et al. Results with a cochlear implant channel-picking strategy based on “Selected Groups.” *Hear Res.* 2010;260:63–69.
29. Nogueira W, Büchner A, Lenarz T, Edler B. A psychoacoustic “NofM”-type speech coding strategy for cochlear implants. *EURASIP J Appl Signal Processing.* 2005; 2005:3044–3059.
30. Flanagan JL. *Speech Analysis, Synthesis and Perception*. 2nd ed. New York, NY: Springer-Verlag; 1972.
31. Ziese M, Stützel A, von Specht H, et al. Speech understanding with the CIS and the n-of-m strategy in the MED-EL COMBI 40+ system. *ORL J Otorhinolaryngol Relat Spec.* 2000;62:321–329.
32. Lawson DT, Wilson BS, Zerbi M, Finley CC. Speech processors for auditory prostheses: 22 electrode percutaneous study—results for the first five subjects. *Third Quarterly Progress Report*, NIH project N01-DC-5-2103. Bethesda, MD: Neural Prosthesis Program, National Institutes of Health; 1996.
33. Pasanisi E, Bacciu A, Vincenti V, Guida M, Berghenti MT, Barbot A, Panu F, Bacciu S. Comparison of speech perception benefits with SPEAK and ACE coding strategies in pediatric Nucleus CI24M cochlear implant recipients. *Int J Pediatr Otorhinolaryngol.* 2002;64:159–163.
34. Skinner MW, Holden LK, Whitford LA, Plant KL, Psarros C, Holden TA. Speech recognition with the nucleus 24 SPEAK, ACE, and CIS speech coding strategies in newly implanted adults. *Ear Hear.* 2002; 23:207–223.
35. David EE, Ostroff JM, Shipp D, Nedzelski JM, Chen JM, Parnes LS, Zimmerman K, Schramm D, Seguin C. Speech coding strategies and revised cochlear implant candidacy: an analysis of post-implant performance. *Otol Neurotol.* 2003;24:228–233.
36. Glasberg BR, Moore BC. Derivation of auditory filter shapes from notched-noise data. *Hear Res.* 1990;47:103–138.
37. Wilson BS, Lawson DT, Zerbi M, Finley CC. Speech processors for auditory prostheses: virtual channel interleaved sampling (VCIS) processors—initial studies with subject SR2. *First Quarterly Progress Report*, NIH project N01-DC-2-2401. Bethesda, MD: Neural Prosthesis Program, National Institutes of Health; 1992.
38. Wilson BS, Zerbi M, Lawson DT. Speech processors for auditory prostheses: identification of virtual channels on the basis of pitch. *Third Quarterly Progress Report*, NIH project N01-DC-2-2401. Bethesda, MD: Neural Prosthesis Program, National Institutes of Health; 1993.

39. Wilson BS, Lawson DT, Zerbi M. Speech processors for auditory prostheses: evaluation of VCIS processors. *Sixth Quarterly Progress Report*, NIH project N01-DC-2-2401. Bethesda, MD: Neural Prosthesis Program, National Institutes of Health; 1994.
40. Wilson BS, Lawson DT, Zerbi M, Finley CC. Recent developments with the CIS strategies. In: Hochmair-Desoyer IJ, Hochmair ES, eds. *Advances in Cochlear Implants*. Vienna: Manz; 1994:103–112.
41. Saoji AA, Litvak LM. Use of “phantom electrode” technique to extend the range of pitches available through a cochlear implant. *Ear Hear*. 2010;31:693–701. Erratum in: *Ear Hear*. 2011;32:143.
42. Wilson BS, Schatzer R, Lopez-Poveda EA. Possibilities for a closer mimicking of normal auditory functions with cochlear implants. In: Waltzman SB, Roland JT Jr, eds. *Cochlear Implants*. 2nd ed. New York, NY: Thieme Medical Publishers; 2006: 48–56.
43. Koch DB, Downing M, Osberger MJ, Litvak L. Using current steering to increase spectral resolution in CII and HiRes 90K users. *Ear Hear*. 2007;28(suppl):39S–41S.
44. Wilson BS, Wolford D, Schatzer R, Sun X, Lawson D. Speech processors for auditory prostheses: combined use of DRNL filters and virtual channels. *Seventh Quarterly Progress Report*, NIH project N01-DC-2-1002. Bethesda, MD: Neural Prosthesis Program, National Institutes of Health; 2003.
45. Wilson BS, Schatzer R, Lopez-Poveda EA, Sun X, Lawson DT, Wolford RD. Two new directions in speech processor design for cochlear implants. *Ear Hear*. 2005;26: 73S–81S.
46. Buechner A, Brendel M, Krüeger B, Frohne-Büchner C, Nogueira W, Edler B, Lenarz T. Current steering and results from novel speech coding strategies. *Otol Neurotol*. 2008;29:203–207.
47. Litvak LM, Krubsack DA, Overstreet EH. Method and system to convey the within-channel fine structure with a cochlear implant. US Patent 7317945; 2008.
48. Nogueira W, Litvak L, Edler B, Ostermann J, Buechner A. Signal processing strategies for cochlear implants using current steering. *EURASIP J Adv Signal Processing*. 2009;2009:1–20.
49. Brendel M, Buechner A, Krueger B, Frohne-Buechner C, Lenarz T. Evaluation of the Harmony sound processor in combination with the speech coding strategy HiRes 120. *Otol Neurotol*. 2008;29:199–202.
50. Donaldson GS, Dawson PK, Borden LZ. Within-subjects comparison of the HiRes and Fidelity120 speech processing strategies: speech perception and its relation to place-pitch sensitivity. *Ear Hear*. 2011;32: 238–250.
51. Drennan WR, Won JH, Nie K, Jameyson E, Rubinstein JT. Sensitivity of psychophysical measures to signal processor modifications in cochlear implant users. *Hear Res*. 2010;262:1–8.
52. Berenstein CK, Mens LH, Mulder JJ, Vanpoucke FJ. Current steering and current focusing in cochlear implants: comparison of monopolar, tripolar, and virtual channel electrode configurations. *Ear Hear*. 2008;29:250–260.
53. Firszt JB, Koch DB, Downing M, Litvak L. Current steering creates additional pitch percepts in adult cochlear implant recipients. *Otol Neurotol*. 2007;28:629–636.
54. McDermott HJ, McKay CM. Pitch ranking with non-simultaneous dual electrode electrical stimulation of the cochlea. *J Acoust Soc Am*. 1994;96:155–162.
55. Kwon BJ, van den Honert C. Dual-electrode pitch discrimination with sequential interleaved stimulation by cochlear implant users. *J Acoust Soc Am*. 2006;120:EL1–EL6.
56. Smith ZM, Delgutte B, Oxenham AJ. Chimaeric sounds reveal dichotomies in auditory perception. *Nature*. 2002;416:87–90.
57. Zeng FG, Nie K, Stickney GS, et al. Speech recognition with amplitude and frequency modulations. *Proc Natl Acad Sci U S A*. 2005;102:2293–2298.
58. Xu L, Pfingst BE. Relative importance of temporal envelope and fine structure in

- lexical-tone perception. *J Acoust Soc Am.* 2003;114:3024–3027.
59. Arnoldner C, Riss D, Brunner M, Baumgartner WD, Hamzavi JS. Speech and music perception with the new fine structure speech coding strategy: preliminary results. *Acta Otolaryngol.* 2007;127:1298–1303.
 60. Krenmayr A, Visser D, Schatzer R, Zierhofer C. The effects of fine structure stimulation on pitch perception with cochlear implants. *Cochlear Implants Int.* 2011;12:S70–S72.
 61. Zeng FG. Temporal pitch in electric hearing. *Hear Res.* 2002;174:101–106.
 62. Wilson BS, Lawson DT, Finley CC, Zerbi M. Speech processors for auditory prostheses: randomized update orders; slow rate CIS implementations; channel number manipulations; evaluation of other promising processing strategies; performance of CIS and CA processors in noise; and use and possible development of new test materials. *Tenth Quarterly Progress Report*, NIH project N01-DC-9-2401. Bethesda, MD: Neural Prosthesis Program, National Institutes of Health; 1991.
 63. Riss D, Arnoldner C, Reiss S, Baumgartner WD, Hamzavi JS. 1-year results using the Opus speech processor with the fine structure speech coding strategy. *Acta Otolaryngol.* 2009;129:988–991.
 64. Riss D, Hamzavi JS, Katzinger M, Baumgartner WD, Kaider A, Gstoettner W, Arnoldner C. Effects of fine structure and extended low frequencies in pediatric cochlear implant recipients. *Int J Pediatr Otorhinolaryngol.* 2011;75:573–578.
 65. Vermeire K, Punte AK, Van de Heyning P. Better speech recognition in noise with the fine structure processing coding strategy. *ORL J Otorhinolaryngol Relat Spec.* 2010;72:305–311.
 66. Riss D, Arnoldner C, Baumgartner WD, Kaider A, Hamzavi JS. A new fine structure speech coding strategy: speech perception at a reduced number of channels. *Otol Neurotol.* 2008;29:784–788.
 67. Magnusson L. Comparison of the fine structure processing (FSP) strategy and the CIS strategy used in the MED-EL cochlear implant system: speech intelligibility and music sound quality. *Int J Audiol.* 2011; 50:279–287.
 68. Brill S, Möltner A, Harnisch W, Müller J, Hagen R. *Temporal fine structure coding in low frequency channels: Speech and prosody understanding, pitch and music perception, and subjective benefit evaluated in a prospective randomized study.* Presented at the 2007 Conference on Implantable Auditory Prostheses, Lake Tahoe, CA, USA, July 15–20, 2007. (Abstract 1E on p. 24 in the conference proceedings.)
 69. Schatzer R, Krenmayr A, Au DK, Kals M, Zierhofer C. Temporal fine structure in cochlear implants: preliminary speech perception results in Cantonese-speaking implant users. *Acta Otolaryngol.* 2010; 130:1031–1039.
 70. Helms J, Müller J, Schön F, Moser L, Arnold W, et al. Evaluation of performance with the COMBI40 cochlear implant in adults: a multicentric clinical study. *ORL J Otorhinolaryngol Relat Spec.* 1997;59:23–35.
 71. Krueger B, Joseph G, Rost U, Strauss-Schier A, Lenarz T, Buechner A. Performance groups in adult cochlear implant users: speech perception results from 1984 until today. *Otol Neurotol.* 2008;29:509–512.
 72. Niparko JK, Tobey EA, Thal DJ, Eisenberg LS, Wang NY, et al. Spoken language development in children following cochlear implantation. *JAMA.* 2010;303:1498–1506.
 73. Holt RF, Svirsky MA. An exploratory look at pediatric cochlear implantation: is earliest always best? *Ear Hear.* 2008;29:492–511.
 74. Dorman MF, Gifford RH. Combining acoustic and electric stimulation in the service of speech recognition. *Int J Audiol.* 2010;49:912–919.
 75. Wilson BS, Dorman MF. Cochlear implants: a remarkable past and a brilliant future. *Hear Res.* 2008;242:3–21.
 76. Spahr AJ, Dorman MF. Performance of subjects fit with the Advanced Bionics CII and Nucleus 3G cochlear implant devices. *Arch Otolaryngol Head Neck Surg.* 2004; 130:624–628.

77. Wilson BS, Lopez-Poveda EA, Schatzer R. Use of auditory models in developing coding strategies for cochlear implants. In: Meddis R, Lopez-Poveda EA, Popper A, Fay RR, eds. *Computational Models of the Auditory System*. New York, NY: Springer-Verlag; 2010:237–260.
78. Wilson BS, Dorman MF, Woldorff MG, Tucci DL. Cochlear implants: matching the prosthesis to the brain and facilitating desired plastic changes in brain function. *Prog Brain Res*. 2011;194:117–129.
79. Oxenham AJ, Bernstein JG, Penagos H. Correct tonotopic representation is necessary for complex pitch perception. *Proc Natl Acad Sci U S A*. 2004;101:1421–1425.
80. Wilson BS, Dorman MF. Cochlear implants: current designs and future possibilities. *J Rehabil Res Dev*. 2008;45:695–730.

Toward better representations of sound with cochlear implants

Blake S Wilson

“From a physiological point of view, cochlear implants will not work.”

This statement by Professor Rainer Klinke in 1978 was not the first criticism of efforts to develop a treatment for deafness using electrical stimulation of the auditory nerve. Klinke was accompanied and preceded by a chorus of experts in otology and hearing science who proclaimed that such an idea was a fool's dream. The cochlea, with its exquisite mechanical machinery, its complex arrangement of more than 15,000 sensory hair cells, and its 30,000 neurons, could not possibly be replaced by a crude and undifferentiated stimulation of many neurons *en masse*. The argument was a good one. However, the pioneers in the field persevered in the face of the vociferous criticism. Foremost among these pioneers was William F. House, who developed with Jack Urban the first cochlear implant system that could be safely applied over a patient's lifetime and that generally provided an awareness of environmental sounds and an aid to lipreading¹. This achievement was a huge step forward.

The House system and other early systems used a single channel of processing to transform sound sensed by a microphone into patterns of electrical stimulation, as well as a single site of stimulation in or on the cochlea. Many or most surviving neurons were stimulated synchronously and in more or less the same way with the single site of stimulation. Only temporal information could be conveyed with these early implants, but it was enough

Blake S. Wilson is a Co-Director of the Duke Hearing Center at the Duke University Medical Center, Durham, North Carolina, USA. He is also an adjunct professor in the Department of Surgery, the Department of Biomedical Engineering, and the Department of Electrical and Computer Engineering at Duke University, Durham, North Carolina, USA. e-mail: blake.wilson@duke.edu

to provide the aforementioned benefits, and it was sufficient in other single-site systems to support some speech recognition for some patients, most notably in the early systems developed by Ingeborg and Erwin Hochmair.

Some of the early developers believed that temporal information was paramount for auditory perception, but other early developers believed that representation of different frequencies with different sites of stimulation in the cochlea was also important, if not the dominant or even the sole code for frequencies. These latter persons included, but were not limited to, Graeme Clark, Donald Eddington, and Michael Merzenich, as well as their respective teams².

My entry into the field

I was trained initially as an electrical engineer but became interested in hearing research first through my solo project to recreate the perception of three-dimensional hearing from the two tracks of information in a stereo long-play (LP) record. I learned aspects of auditory psychophysics in the project and was fascinated by the intricacies of hearing.

I later became keenly aware of the problems of deafness and severe hearing losses through another project, which aimed to provide supplementary information for deaf persons automatically and in real time to disambiguate the challenges of lipreading. This project involved analyzing speech with a small computer and relaying the output of the speech analysis to a set of light-emitting diode (LED) displays mounted on the stems of eyeglasses, such that the LED displays projected virtual images that the user could see to either side of the lips of a person speaking to her or him. This second project was directed by Robert L. Beadles and was conducted at the Research Triangle Institute (RTI) in the Research Triangle Park in North Carolina, USA, where I also was employed. I assisted Bob in the project from 1974 through much of 1978.



Figure 1 The RTI team in 1986. From left to right are Charles Finley, Blake Wilson and Dewey Lawson.

In 1977 I applied for and won an RTI professional development award to visit three of the four centers in the United States that were then active in the development and first applications of cochlear implants. I wanted to learn more about what these centers were doing and whether I could be helpful in any of their ongoing efforts, such as in the area of speech analysis.

I visited Bill House and members of his team in Los Angeles; Blair Simmons, Robert White, and other members of the team at Stanford University; and Mike Merzenich and his team at the University of California at San Francisco (UCSF). The visits were in 1978, the same year Professor Klinke made the statement I quoted above. After my visit to UCSF, Mike asked me to be a consultant for the project there. I happily agreed, and that was the beginning of my direct involvement in the field of cochlear implants.

‘Speech processors’ projects

A few years later, in 1983, I won the first in a series of seven contiguous projects to develop cochlear implants, with an emphasis on design and evaluation of novel processing strategies for implants. These projects were supported

through the Neural Prosthesis Program at the US National Institutes of Health (NIH), and they spanned 23 years. Advances we made in these projects are among the advances being honored by the 2013 Lasker-DeBakey Clinical Medical Research Award.

Our first studies with implant patients were conducted at UCSF. Mike Merzenich and many others there were our gracious hosts, and they all helped us mightily in getting started.

In late 1984, I received a call from Joseph C. Farmer Jr., who was an otologic surgeon at Duke. Joe mentioned that he had heard about our work at UCSF and wondered whether we might want to work a little closer to home, at Duke University, less than ten miles from the RTI. Of course, I thought Joe's idea was wonderful and welcomed it, so long as we could continue our partnership with UCSF, which we did for many years. We built a laboratory at Duke in 1985 and conducted most of our patient studies there for the next ten years, at which point we built two new laboratories at the RTI, one for speech-reception studies and the other for evoked-potential studies. We made a transition to the RTI laboratories over the next two years and all subsequent studies were conducted at the RTI.

Joe, I and others also founded the Cochlear Implant Program at Duke in 1985, which was one of the first such programs in the US. The first two implants in the program were experimental devices provided by UCSF. The implant recipients who were fit with these devices were studied intensively in the Duke laboratory and in close cooperation with investigators at UCSF.

A comprehensive description of the seven NIH projects—and the studies in the UCSF, Duke and RTI laboratories—is presented in a recent book³.

Composition of the teams

The projects started small, but they grew in scope and size across the years. By the fall of 1984 we had a core team of three investigators (**Fig. 1**) and a part-time administrative assistant. In late 1990 the core team included four investigators and a full time administrative assistant, and by 1996 the number of investigators had grown to five and then in 2000 to six. The team in 2001 along with two visitors is shown in **Figure 2**, and the changing composition of the teams over the years is depicted on page 7 in ref. 3.

Although our focus was on the development of better processing strategies for implants, the work also included tool building and many other areas of research that are listed on pages 16 and 17 in ref. 3. A hallmark of the projects was joint efforts with many investigators worldwide. These partnerships greatly extended the reach of our core teams.



Figure 2 Members of the RTI team in 2001, along with a research subject and his wife. From left to right are Jeannie Cox, Stefan Brill, Reinhold Schatzter, Denis Fitzgerald (the research subject), Heather Fitzgerald (Denis's wife), Robert Wolford, Dewey Lawson and Blake Wilson. Not shown is team member Lianne Cartee. The Fitzgeralds visited the RTI laboratories from their home in St. Asaph, Wales, UK.

Continuous interleaved sampling

We developed and tested many processing strategies during the projects, and many of the strategies are in widespread clinical use today. However, one strategy towers above the rest in terms of the improvement in performance over its predecessors and in terms of impact. That strategy is the continuous interleaved sampling (CIS) strategy, invented in 1989 and tested with an initial set of cochlear implant patients in 1989 and 1990. The results from those studies were published in *Nature* in 1991 (ref. 4). This publication became the most highly cited publication in the specific field of cochlear implants at the end of 1999 and has remained so ever since.

By 1989, groups in Australia, Europe and the US had developed multielectrode arrays that could be safely inserted into the scala tympani of the cochlea and that could excite different sectors (or tonotopic regions) of the auditory nerve, depending on which intracochlear electrode or which closely spaced pair of intracochlear electrodes was activated. Thus, stimulation of an electrode near the basal end of the cochlea would elicit a high-pitched percept, stimulation at the other end of the cochlea would elicit a low-pitched percept, and stimulation at intermediate positions would elicit intermediate pitches.

The status of the field at that time is accurately expressed in the conclusions from

the first NIH Consensus Development Conference on Cochlear Implants, which was convened in 1988. Two of these conclusions were that multisite systems were more likely to be effective than single-site systems, and that “about 1 in 20 patients could carry out a normal conversation without lipreading,” using the best of the multisite systems⁵. The introduction of the multisite systems was another great step forward for cochlear implants, but even moderate levels of speech recognition using the restored hearing alone were still rare.

CIS was a breakthrough in sound processing that used the multiple sites far better than before, and thereby enabled high levels of speech recognition for the great majority of cochlear implant users. Unlike some prior strategies (including strategies we developed), this new strategy did not make any assumptions about how speech is produced or perceived, or about what might be important in the input. That is, the new strategy did not extract and then represent any specific features in the input, such as the fundamental frequency of voiced speech sounds, the periodicity or aperiodicity of inputs, or an inferred resonance frequency of the vocal tract in producing a speech sound. Instead, the strategy was designed to reproduce as many aspects of the input as possible, and then to allow the user's brain to decide what was (or was not)



Figure 3 The payoff: what the intervention and associated technology can do for deaf and severely hearing-impaired persons. A user of a cochlear implant is conversing with the author. The joy in the exchange is obvious, and she clearly is not having any difficulty in understanding me even though she is not looking at my lip movements and the conversation included many different and unpredictable topics. The cochlear implant user is Lilo Baumgartner from Vienna, Austria; the photo was taken at an outside location near our RTI laboratories in September 2003.

important in the input. This design decision proved to be crucial, as considerable information that could be perceived was discarded in the previous approaches, and the accuracy of feature extraction was very poor in typical acoustic environments with noise, reverberation and multiple talkers, even when using the most advanced signal processing techniques of the time.

In addition, unlike some other previous strategies, the new strategy did not stimulate the multiple electrodes in the implant simultaneously but instead sequenced brief stimulus pulses from one electrode to the next until all of the used electrodes had been stimulated. This pattern of stimulation across electrodes was repeated continuously, and each such 'stimulus frame' presented updated information. This decision also proved to be crucial, in that the simultaneous stimulation produced spurious interactions ('cross talk') among the electrodes and thereby greatly degraded the perception of the 'place of stimulation' (frequency-based) cues.

A further departure from the past was that, for pulsatile processors, the rate of stimulation was very much higher than had been used previously. The high rates allowed a fine-grained representation of temporal information at each of the used electrodes; thus, both place information and temporal information were represented with CIS, up to or near the limits of perception for both codes.

Many additional aspects and features of CIS are listed on page 10 in ref. 3, and details about the design are presented elsewhere in the same book and in refs. 2 and 4. In broad terms, CIS combined the best elements from disparate prior strategies and added some new elements as well. The combination produced unprecedented levels of speech recognition with cochlear implants. After this and other advances, the NIH convened another conference in 1995, the Consensus Development Conference on Cochlear Implants in Adults and Children⁶. A principal conclusion from that conference was that "A majority of those individuals with the latest speech processors for their implants will score above 80 percent correct on high-context sentences, even without visual cues."⁶

The introduction of CIS into widespread clinical use in the early 1990s was soon followed by exponential growth in the number of implant recipients, which persists to this day. CIS is still used and is the basis for many of the strategies developed subsequently, which also no doubt helped to fuel the growth in implant numbers. Even today, CIS remains the standard against which other promising strategies are compared.

In retrospect, those of us who designed implant systems had to 'get out of the way' and allow the brain to do its work. Once given a relatively clear and unfiltered input, the brain could do the rest.

From speech to sound processors

At the beginning of our work, we were delighted when a research subject could recognize, with hearing alone, even short fragments of ongoing speech or more than two or three single-syllable words in a list of 50. The sole emphasis of our group and others was to convey more information about speech. We designers did not think about other sounds.

Happily, those early days are history and today many patients score at or near 100% correct in recognizing sentences and above 80% correct in recognizing single-syllable words, with the speech items presented in quiet and using the restored hearing alone. In fact, we are now at the point at which investigators are calling for more difficult tests because the standard audiological tests are no longer sufficiently sensitive to detect differences among implant systems, patients or processing strategies, at least for the top-performing patients⁷. Such a lack of sensitivity (due to ceiling effects) is a happy problem to have.

With these great advances in prosthesis design and performance, the emphasis has shifted to music reception and to recognition of speech in especially adverse acoustic environments, such as noisy restaurants or workplaces. We now think in terms of sound processors rather than speech processors. The present goal is to represent sound as faithfully as possible so that the brain will have access to the greatest possible amount of information, and not just to speech information or features abstracted from speech. This shift in emphasis is a sign of the progress that has been made.

A lucky engineer

Ronald Vale wrote a wonderful essay⁸ for last year's special issue of *Nature Medicine* celebrating the Lasker Awards. The title of his essay was: 'How lucky can one be? A perspective from a young scientist at the right place at the right time.' The essay resonated with me, as I experienced many of the same feelings and learned some of the same lessons Ron so eloquently described. I would only substitute the word 'engineer' for the word 'scientist' to describe my own experience. I had the great fortune to work on a problem that so adversely affected millions of people, and to do that work in the company of spectacular colleagues.

A few further lessons learned along the way

Further lessons I learned that pertain more directly to the development of neural prostheses are:

- Persevere: the experts are not always correct.

- Try not to make assumptions about what the brain might need for optimal perception.
- Know that a surprisingly sparse representation may be adequate for a substantial restoration of function with neural prostheses.
- However, also know that a threshold of quality and quantity of information probably needs to be exceeded before the brain can do its work or at least work effectively.
- Respect the brain for its enormous capabilities and work to forge a good partnership between the brain and the prosthesis.
- Evaluate many ideas, because only a tiny fraction may emerge as good ones in practice; as Alfred Nobel famously said, “If I have 300 ideas in a year and just one turns out to work I am satisfied.”
- Multidisciplinary teams are needed to create successful neural prostheses.

Concluding remarks

Even though I have been working in the field of cochlear implants for well over 30 years, I am as excited as ever about the possibilities for the future^{2,9,10}. The work has been one incredible

ride and among the great adventures of my life. The best parts have been the interactions with patients (Fig. 3) and seeing them flourish with their restored hearing.

ACKNOWLEDGMENTS

The principal support for our work was provided by the NIH. This support included funding for the seven projects described in this essay plus additional projects also in the field of cochlear implants. Further financial and other support was provided by the RTI, Duke University, UCSF, the University of Iowa, MED-EL, Cochlear Americas, Advanced Bionics and the Storz Instrument Company. Of course, we could not have done anything without our research subjects, and we were blessed with some of the best. Indeed, we were continually amazed by their engagement in the studies, and by their generosity in spending time with us and in helping to improve the human condition. Many sponsors, research subjects, administrators, collaborating investigators and colleagues at the cochlear-implant companies made essential contributions to our shared efforts. The most important source of support for me is my wonderful family. We have had spectacularly good times together, and my wife and our two daughters have tolerated with gracious good humor my ‘daydreams’ and my time away in intense work or protracted travel. I am so very lucky.

COMPETING FINANCIAL INTERESTS

The author declares no competing financial interests.

1. Bilger, R.C. *et al.* Evaluation of subjects presently fitted with implanted auditory prostheses. *Ann. Otol. Rhinol. Laryngol.* **86** (3, Pt. 2, Suppl. 38), 1–176 (1977).
2. Wilson, B.S. & Dorman, M.F. Cochlear implants: a remarkable past and a brilliant future. *Hear. Res.* **242**, 3–21 (2008).
3. Wilson, B.S. & Dorman, M.F. *Better Hearing with Cochlear Implants: Studies at the Research Triangle Institute* (Plural, 2012).
4. Wilson, B.S. *et al.* Better speech recognition with cochlear implants. *Nature* **352**, 236–238 (1991).
5. National Institutes of Health. Cochlear implants. *NIH Consens. Statement* **7**(2), 1–9 (1988).
6. National Institutes of Health. Cochlear implants in adults and children. *NIH Consens. Statement* **13**(2), 1–30 (1995).
7. Gifford, R.H., Shallop, J.K. & Peterson, A.M. Speech recognition materials and ceiling effects: considerations for cochlear implant programs. *Audiol. Neurootol.* **13**, 193–205 (2008).
8. Vale, R.D. How lucky can one be? A perspective from a young scientist at the right place at the right time. *Nat. Med.* **18**, 1486–1488 (2012).
9. Wilson, B.S., Dorman, M.F., Woldorff, M.G. & Tucci, D.L. Cochlear implants: matching the prosthesis to the brain and facilitating desired plastic changes in brain function. *Prog. Brain Res.* **194**, 117–129 (2011).
10. Wilson, B.S. & Dorman, M.F. Signal processing strategies for cochlear implants. in *Cochlear Implants and Other Implantable Hearing Devices* (ed. Ruckenstein, M.J.) (Plural, 2012).

Resource Review (Invited)

Better Hearing With Cochlear Implants: Studies at the Research Triangle Institute. Blake Wilson and Michael F. Dorfman. San Diego, CA: Plural Publishing. (2012). 470 pp. ISBN: 978-1-59756-253-9.

Reviewed by Mario Svirsky, Ph.D.
Noel L. Cohen Professor of Hearing Science
Professor of Otolaryngology (School of Medicine) and Neural
Science Vice-Chairman for Research
Department of Otolaryngology
NYU Langone Medical Center
550 First Avenue, NBV-5E5
New York, NY 10010, USA

Cochlear implants remain the only example to date of an electronic device successfully replacing a human sensory end organ, and they represent one of the major medical advances of the twentieth century. This has been recently recognized by the Lasker Foundation by giving the prestigious Lasker-DeBakey Clinical Medical Research Award to Blake Wilson, Graeme Clark, and Ingeborg Hochmair, “for the development of the modern cochlear implant—a device that restores hearing and speech to individuals with total or nearly complete deafness.” The Lasker Awards are second only to the Nobel Prize in Physiology or Medicine for honoring advances in medicine and medical science. Indeed, fully a third of the Lasker winners go on to win the Nobel Prize at a later time.

One of the Lasker awardees, Blake Wilson, and Michael Dorfman (who is another pioneer and major contributor to the development of cochlear implant technology) describe the body of research and development work done at Research Triangle Institute (RTI) between 1983 and 2006. This work was largely funded by a series of contracts from the National Institute of Health’s Neural Prostheses Program. One important characteristic of the Neural Prostheses Program was that a quarterly progress report (QPR) was required. These QPRs (which can still be found on the Web site http://www.nidcd.nih.gov/funding/programs/npp/pages/neural-prostheses_archive_reports.aspx) were for many years one of the best-kept secrets in the cochlear implant field. (Full disclosure: I was an investigator in a similar contract awarded to Massachusetts Institute of Technology (MIT) in 1992, with Don Eddington as Principal Investigator). The QPRs were not, by any means, the only source of information about RTI cochlear implant research. After all, Appendix C of the present book lists 65 publications that resulted from RTI projects. Many of these publications were highly influential. A description of the first results obtained with the continuous interleaved sampling (CIS) stimulation strategy, that was published in *Nature* in 1991, remains to this day the most highly cited publication in the cochlear implant field. Nevertheless, QPRs from the RTI research group were highly sought after for over two decades by eager investigators who wanted to quickly find out what this elite team was working on. Information could be obtained in a much more timely fashion by reading the QPRs than if one had to wait for the whole peer review and publication process to complete,

and the information itself was frequently much more detailed and richer in the QPR than in the peer-reviewed publications. Readers of the QPRs were aware that the reports had not been subjected to the same level of scrutiny as a publication in an archival journal would have been, but they appreciated the trade-off of being able to access the data much more quickly. In other words, the material in the QPRs was useful in a way that was complementary to that of peer-reviewed publications. Perhaps the main problem was that, because of its very nature, the data in the reports were simply organized in a chronological fashion, quarter by quarter, and it was not easy to access all the information about a given topic without having prior knowledge of which specific report one should peruse.

The publication of *Better Hearing with Cochlear Implants* goes a long way toward filling this void. Information is carefully organized according to theme and topic. The first part is about design and evaluation of novel processing strategies, and it includes information about the initial development of the CIS speech-processing strategy, its comparison with other strategies, the evaluation of other promising strategies, and a series of studies done with relatively poor performers. There is also a chapter about studies done with auditory brainstem implant users, and three chapters that explore the concept of “virtual channels.” Chapter 12 is dedicated to the design of an inexpensive but effective cochlear implant system. The last chapter in this part describes studies done with a cochlear implant that used a 22-electrode percutaneous array, an interesting device that allows much greater flexibility in stimulation parameters than the clinically available systems, which must rely on transcutaneous stimulation. Part two covers bilateral cochlear implant studies and focuses on the study of sensitivity to interaural timing differences as well as pitch ranking across the two electrode arrays. The third part examines combined electric and acoustic stimulation of the auditory system, with one chapter dedicated to psychophysical studies and another related to speech perception. The fourth and final part presents studies of the representation of temporal information with cochlear implants and the ways in which such representation might be improved by appropriate adjustments in the stimulation strategy. As will become clear to the reader, the RTI group pioneered many of the approaches described in the book. The book is engaging, clear, and very well written. It is obvious that a substantial amount of reflection and effort went into preparing the book, this was not at all a simple but massive “cut-and-paste” exercise from the QPRs. The authors present much information from the QPRs, but they also provide appropriate historical and technical context. An extremely useful resource to those readers who want to follow up by reading the original QPRs can be found in Appendix D, which lists QPR contents sorted by topic.

Besides the technical information, readers will find the book interesting as an important contribution to the study of cochlear implant research history. Much information along these lines is contained in the Acknowledgments section, in the overview provided in Chapter 1, as well as in many of the other chapters that deal predominantly with technical information. I highly recommend this book to any reader with a personal or professional interest in cochlear implants, either from a historical perspective or a strictly technical perspective.

Biographical Sketch for Prof. Blake S. Wilson

Prof. Wilson was initially trained as an electrical engineer but also became a leading scientist in the fields of hearing research, remediation of hearing loss, and neural prostheses. He has a B.S.E.E. degree from Duke University and the D.Sc. and D.Eng. degrees from the University of Warwick and the University of Technology, Sydney, respectively. In addition, he has received an honorary doctor of medicine degree from Uppsala University and an honorary Doctor of Science degree from the University of Salamanca. He has led or co-led many multidisciplinary teams during the past three decades.

He began his career at the Research Triangle Institute (RTI) in the Research Triangle Park (RTP), NC, USA. His positions there included Research Engineer (1974-78); Senior Research Engineer (1978-83); Head of the Neuroscience Program (1983-94); Director of the Center for Auditory Prosthesis Research (1994-2002); and Senior Fellow (2002-2007). He with others created the Neuroscience Program and the Center for Auditory Prosthesis Research. RTI is a large not-for-profit research institute with 2800 employees at many locations worldwide. Prof. Wilson retired from the RTI in 2007 following 33 years of continuous service. Much of the work he directed while at the RTI is described in the book by him and Michael F. Dorman, "Better Hearing with Cochlear Implants: Studies at the Research Triangle Institute" (Plural, 2012), and a review of the book is presented in the journal *Ear and Hearing*, vol. 35, page 137.

After retiring from the RTI, Prof. Wilson continued his positions as an Adjunct Professor in the Department of Surgery at the Duke University Medical Center (DUMC) and as The Overseas Expert for a large project at five centers in Europe funded by the EC and aimed at the remediation of hearing loss. In addition, he accepted new positions in 2007 and later. His current positions include:

- Adjunct Professor, Department of Surgery, DUMC (since 2002)
- Chief Strategy Advisor for MED-EL Medical Electronics GmbH, Innsbruck, Austria (since 2007)
- Co-Director (with Co-Director Debara L. Tucci, M.D.), Duke Hearing Center, DUMC (since 2008)
- Investigator, Duke Institute for Brain Sciences (DIBS), Duke University (since 2008)
- Adjunct Professor, Department of Electrical and Computer Engineering at Duke (since 2009)
- Director, MED-EL Basic Research Laboratory, RTP, NC, USA (since 2011)
- Honorary Professor, University of Warwick, Coventry, UK (since 2012)
- Adjunct Professor, Department of Biomedical Engineering at Duke (since 2012)
- Scholar in Residence, Pratt School of Engineering, Duke University (since 2013)
- Member of the affiliated faculties for the DIBS and the Duke Global Health Institute (since 2013)

Prof. Wilson is the inventor of many of the speech processing strategies used with the present-day cochlear implants, including the continuous interleaved sampling (CIS), spectral peak picking (e.g., "n-of-m"), and virtual channel strategies, among others. One of his papers, in the journal *Nature*, is the most highly cited publication by far in the specific field of cochlear implants. He has served as the Principal Investigator for 26 projects, including 13 projects for the United States' National Institutes of Health. In addition, he created with Dr. Joseph C. Farmer, Jr., and others the Duke Cochlear Implant Program in 1984, and he created with Drs. Farmer, Tucci, and Joseph M. Corless and others the Duke Hearing Center in 2008.

Prof. Wilson – or he and his teams or colleagues – have received a high number of highly prestigious awards and honors, including for three examples among many the 2013 Lasker-DeBakey Clinical Medical Research Award, "for the development of the modern cochlear implant" (to Wilson, Graeme M. Clark, and Ingeborg J. Hochmair); the American Otological Society President's Citation in 1997, "for major contributions to the restoration of hearing in profoundly deaf persons" (to Wilson, Dewey T. Lawson, Charles C. Finley, and Mariangeli Zerbi); and the 1996 Discover Award for Technological Innovation in the category of "sound" (to Wilson). In addition, Prof. Wilson has been the Guest of Honor (GOH) at 13 international conferences and at three national conferences to date. He has given GOH, keynote, or other invited talks at more than 180 conferences, and he has given or is scheduled to give eight named lectures. A complete list of awards and honors is presented in his full CV, as are complete lists of publications, books, major reports, patents, chaired conferences, chaired sessions within conferences, and the talks.

CURRICULUM VITAE for Prof. Blake S. Wilson (as of October 2014)

Current Positions: *Co-Director* (with *Co-Director* Debara L. Tucci, M.D.)
Duke Hearing Center
Duke University Medical Center (DUMC)
Durham, NC 27710, USA

Adjunct Professor
Department of Surgery
Division of Otolaryngology – Head & Neck Surgery
DUMC

Adjunct Professor
Department of Electrical and Computer Engineering
Duke University
Durham, NC 27708, USA

Adjunct Professor
Department of Biomedical Engineering
Duke University

Scholar in Residence
Pratt School of Engineering
Duke University

Investigator and Member of the Faculty Network
Duke Institute for Brain Sciences
Duke University

Affiliated Faculty
Duke Global Health Institute
Duke University

Honorary Professor
School of Engineering
University of Warwick
Coventry CV4 8UW, UK

Chief Strategy Advisor
MED-EL Medical Electronics GmbH
A-6020 Innsbruck, Austria

Director
MED-EL Laboratory for Basic Research
Research Triangle Park, NC 27709, USA

Lasker Laureate and Life Fellow of the IEEE

Positions and Experience

1974 to 2007: Several positions at the Research Triangle Institute (now RTI International) in the Research Triangle Park (RTP), NC, USA, including Research Engineer (1974-78); Senior Research Engineer (1978-83); Senior Research Scientist (1979-83); Head, Neuroscience Program (1983-94); Director, Center for Auditory Prosthesis Research (1994-2002); and Senior Fellow (2002-07). (Wilson created the Neuroscience Program and the Center for Auditory Prosthesis Research at the RTI with assistance and permissions from others, and he served as the first director for both the Program and the Center. He retired from RTI in 2007 after 33 years of continuous service there.)

2006 to 2010: The Overseas Expert, Marie Curie Project for the Remediation of Hearing Loss, five centers in Europe and with the International Center of Hearing and Speech in Kajetany (near Warsaw), Poland, serving as the lead center. (The Marie Curie projects have one term only.)

1984 to date: Adjunct appointments in the Department of Surgery, Duke University Medical Center (DUMC), Durham, NC, USA, including Assistant Professor (1984-94); Associate Professor (1994-2002); and full Professor (2002 to date).

2007 to date: Chief Strategy Advisor, Med El GmbH, Innsbruck, Austria. (This is a half-time consulting position.)

2008 to date: Co-Director (with Co-Director Debara L. Tucci, M.D.), Duke Hearing Center, DUMC. (Drs. Farmer, Tucci, Wilson, and Corless created the Duke Hearing Center with assistance and permissions from many others.)

2008 to date: Investigator, Duke Institute for Brain Sciences, Duke University, Durham, NC, USA.

2009 to date: Adjunct Professor, Department of Electrical and Computer Engineering, Duke University.

2011 to date: Director, MED-EL Laboratory for Basic Research, RTP, NC, USA.

2012 to date: Honorary Professor, School of Engineering, University of Warwick, Coventry, UK.

2012 to date: Adjunct Professor, Department of Biomedical Engineering, Duke University.

2013 to date: Scholar in Residence, Pratt School of Engineering, Duke University. (Wilson is the first Scholar in Residence for the Pratt School and the position was created for him.)

2013 to date: Member of the Faculty Network, Duke Institute for Brain Sciences, Duke University, Durham, NC, USA.

2013 to date: Member of the Affiliated Faculty, Duke Global Health Institute, Duke University, Durham, NC, USA.

Experience in these positions includes direction, as Principal Investigator, of 26 projects (13 for the NIH). Among the projects is a series of seven contiguous projects to develop speech processors for auditory prostheses (1983-2006: NIH N01-NS-3-2356, N01-NS-5-2396, N01-DC-9-2401, N01-DC-2-2401, N01-DC-5-2103, N01-DC-8-2105, and N01-DC-2-1002).

The experience also includes supervision of, or participation in, many other projects in the fields of neural prostheses and remediation of hearing loss.

The above positions include more than 30 years of continuous service to the RTI and more than 25 years of continuous service to Duke University.

Degrees

B.S.E.E., Duke University, Durham, NC, USA
D.Sc., University of Warwick, Coventry, UK
Dr.med.*hc*, Uppsala University, Uppsala, Sweden
Dr.sci.*hc*, University of Salamanca, Salamanca, Spain

Notes: The D.Sc. degree is one of the higher doctorates and is only awarded at a much higher standard than the standard used for the traditional Ph.D. degree. The higher doctorate is rarely awarded and is the highest among the terminal degrees in the arts, sciences, and engineering. The two “*hc*” (*honoris causa*) degrees are honorary doctorates in medicine and science.

Major Awards and Honors

Medal of Honor from the Paul Sabatier University in Toulouse, France, June 18, 2015. (This Medal will be presented by the President of the University. He will confer separate Medals to Wilson, Graeme M. Clark, M.D., and Ingeborg J. Hochmair, Ph.D., “for the development of the modern cochlear implant.”)

A major international prize that will be announced in early January 2015.

Honorary doctorate in science from the University of Salamanca in Salamanca, Spain, approved by the University Council on November 27, 2014 and to be conferred at the June 2015 conferment ceremony in Salamanca.

Appointment as a Life Fellow of the IEEE, November 24, 2015. (The Fellow appointment is the highest honor conferred by the IEEE and less than 0.1 percent of the voting members are elevated to the Fellow grade each year.)

Honorary doctorate in medicine from Uppsala University in Uppsala, Sweden, approved by the Faculty of Medicine in September 2014 and to be conferred at the winter conferment ceremony in Uppsala on January 30, 2015.

Inaugural inductee – along with Robert J. Lefkowitz, M.D. and winner of the 2012 Nobel Prize in Chemistry, and Mary-Dell Chilton, Ph.D. and winner of the 2013 World Food Prize – into the Bull City Hall of Fame, March 27, 2014. (Durham, North Carolina, USA, also is known as the “Bull City” and “The City of Medicine.” It is the home of Duke University, the Duke University Health System, North Carolina Central University, and the Durham Performing Arts Center. Durham is a vibrant city with a diverse population of about 240,000.)

Recipient of the first commendation from the *American Cochlear Implant Alliance*, “in recognition of the lifetime contributions of 2013 Lasker Award winner Dr. Blake S. Wilson in serving those with hearing loss through his remarkable contributions to the science of cochlear implantation,” October 24, 2013.

Appointment as the first Scholar in Residence for the Pratt School of Engineering at Duke University, September 13, 2013. (This appointment was created for Wilson and has a five-year term that is renewable.)

The 2013 Lasker-DeBakey Clinical Medical Research Award, shared with Graeme M. Clark, M.D., and Ingeborg J. Hochmair, Ph.D., “for the development of the modern cochlear implant – a device that bestows hearing to individuals with profound deafness,” September 9, 2013. (The Lasker Awards are among the most respected science prizes in the world and are second only to the Nobel Prize in Physiology or Medicine for recognizing advances in medicine and medical science; indeed, fully a third of the winners of a Lasker Award go on to win the Nobel Prize at a later time. The Lasker Awards are popularly known as “America’s Nobels.” Only about 250 persons have received a Lasker Award since the inception of the awards program in 1945. Please see <http://www.laskerfoundation.org/> for further details about the Lasker Foundation and its awards.)

Co-Chair, with Co-Chair Christoph von Ilberg, M.D., of the *Presbycusis Research Meeting*, Munich, Germany, January 12-14, 2012.

Guest of Honor (along with Jan Helms, M.D.), *Munich Hearing Implant Symposium: Reaching New Heights*, Munich, Germany, December 8-10, 2011.

Guest of Honor, *Ninth European Symposium on Paediatric Cochlear Implantation*, Warsaw, Poland, May 14-17, 2009. (This Symposium is among the largest conferences in the field of cochlear implants; more than 1,700 delegates attended the symposium in Warsaw, which was an all-time high for these symposia.)

One of Wilson’s inventions was named as one of the four greatest inventions or discoveries in the 50-year history of the Research Triangle Park (RTP), as announced in the Triangle Business Journal, February 27, 2009. (The RTP is the largest research park in the USA and includes more than 170 research organizations whose aggregate number of full-time employees exceeds 42,000. The other named inventions or discoveries were the UPC barcode, invented at IBM; the anti-cancer drug Taxol, discovered and developed at the Research Triangle Institute; and the anti-viral drug AZT used to treat HIV-AIDS, invented at GlaxoSmithKline.)

Invitation to give the Neel Distinguished Research Lecture at the *Annual Meeting of the American Academy of Otolaryngology, Head & Neck Surgery*, Chicago, IL, USA, September 21-24, 2008. (The two-part lecture for this year was given with Richard T. Miyamoto, M.D., Chair of Otolaryngology – Head & Neck Surgery at the Indiana University School of Medicine; the attendance for the *Annual Meeting* approximated 8,500. The prior Neel Lecture was given in 2007 by Elias Zerhouni, M.D., the Director of the NIH.)

Invitation to write the lead article for the special issue of the journal *Hearing Research* on *Frontiers of Auditory Prosthesis Research: Implications for Clinical Practice*. (The special issue was published in September 2008 and included 18 articles.)

Guest of Honor, *Friedberger Cochlear Implant Symposium*, Bad Nauheim, Germany, June 28-30, 2007.

2007 recipient of the Distinguished Alumnus Award, Pratt School of Engineering, Duke University, April 21, 2007.

Guest of Honor, *Sixth Wullstein Symposium 2006: New Developments in Hearing Technology*, Würzburg, Germany, December 7-10, 2006.

Chair, with Co-Chair Michael F. Dorman, Ph.D., of the *Hearing Preservation Workshop V*, Research Triangle Park, NC, USA, October 13-15, 2006.

Guest of Honor, *Workshop on the Present Status and Future Directions of Cochlear Implants*, Nano Bioelectronics & Systems Research Center, Seoul National University, Seoul, Korea, August 25, 2006.

Guest of Honor, *Meeting of the Clinical Otologic Research Team (CORT)*, Cal-Creek Ranch, near Santa Fe, NM, USA, August 8-12, 2006. (The CORT includes leading otologists in the United States.)

Named as an honorary member of the CORT, August 2006.

Special Guest of Honor, *Ninth International Conference on Cochlear Implants and Related Sciences*, Vienna, Austria, June 14-17, 2006. (Blake Wilson, Graeme M. Clark, and James F. Battley, Jr. are the only people to be so honored in this series of the largest conferences in the field of cochlear implants; the Vienna Conference was attended by more than 1,600 delegates from more than 70 countries.)

Guest of Honor, Naval Science & Technological Laboratory, Visakhapatnam, India, March 27-28, 2006.

Guest of Honor, *Hearing Preservation Workshop IV*, Warsaw-Kajetany, Poland, October 14-15, 2005.

Guest of Honor and the Keynote Speaker for the *Annual Meeting of the British Cochlear Implant Group: Pushing the Boundaries of Cochlear Implantation*, Birmingham, UK, April 18-19, 2005.

Guest of Honor, Annual Nalli Family Day, The Hospital for Sick Children, University of Toronto, Toronto, Canada, February 17, 2005.

Guest of Honor, *Fifth Wullstein Symposium on Bilateral Cochlear Implants and Binaural Signal Processing*, Würzburg, Germany, December 2-5, 2004.

Co-Chair, with Chair Peter S. Roland, M.D., of the *Third Hearing Preservation Workshop*, Dallas, TX, USA, October 15-16, 2004.

Designation as a "Friend Forever" to the International Center of Hearing and Speech in Kajetany (near Warsaw), Poland, October 14, 2004.

Special Guest, *Eighth International Cochlear Implant Conference*, Indianapolis, IN, USA, May 10-13, 2004.

Guest of Honor, *Hearing Preservation Workshop II*, Frankfurt, Germany, October 17-18, 2003.

Guest of Honor, *Wullstein Symposium 2002 (3rd Conference on Bilateral Cochlear Implantation and Bilateral Signal Processing, 7th International Cochlear Implant Workshop, and 1st Workshop on Binaural Rehabilitation)*, Würzburg, Germany, December 12-17, 2002.

Co-Chair, with Chair Richard T. Miyamoto, M.D., of the *Hearing Preservation Workshop*, Indiana University School of Medicine, Indianapolis, IN, USA, November 8-10, 2002.

Named as an Honorary Member of the British Cochlear Implant Group, September 6, 2002.

Appointment as one of the first four Senior Fellows for RTI International, September 2002. (RTI International is a large not-for-profit research institute with a staff of more than 2,800 at locations in the United States, Africa, Europe, the United Arab Emirates, Indonesia, and El Salvador; one of the principal charges of the Fellows is to serve as advisors to the RTI President in setting the scientific directions for the organization.)

Guest of Honor, *Wullstein Symposium (2nd Conference on Bilateral Cochlear Implantation and Bilateral Signal Processing, 6th International Cochlear Implant Workshop and 2nd Auditory Brainstem Implant (ABI) Workshop)*, Würzburg, Germany, April 26-30, 2001.

Guest of Honor, *5th International Cochlear Implant Workshop and 1st Auditory Brainstem Implant (ABI) Workshop*, Würzburg, Germany, June 30 to July 4, 1999.

Recipient of the Presidential Citation for "Major contributions to the restoration of hearing in profoundly deaf persons," on the occasion of the 130th Annual Meeting of the American Otological Society, Scottsdale, AZ, USA, May 10-11, 1997. (This Citation was to Wilson, Dewey T. Lawson, Charles C. Finley, and Mariangeli Zerbi, who were the principal members of the team at the Research Triangle Institute at the time.)

Invitation to write a Guest Editorial in celebration of the 30th anniversary of the British Journal of Audiology (1997).

Winner of the 1996 Discover Award for Technological Innovation in the category of "sound."

Guest of Honor, *International Workshop on Cochlear Implants*, Vienna, Austria, October 24-25, 1996.

Elected General Chair of the *1991 Conference on Implantable Auditory Prostheses*, Pacific Grove, CA, USA, June 2-7, 1991.

Selected Professional Activities and Additional Awards and Honors

Inventor of many of the speech processing strategies used with present-day cochlear implant systems. Listed in *Who's Who in the World*, *Who's Who in America*, *Who's Who in Science and Engineering*, *Who's Who in Finance and Industry*, 2000 Outstanding People of the 20th Century (IBC, Cambridge), *Strathmore's Who's Who*. (Each of these listings has been in place for more than a decade.)

Recipient of three Professional Development Awards from the Research Triangle Institute (1977, 1983 and 1988; the award in 1977 was one of the three awards granted in the first year of the program).

The Overseas Expert for a large training and research project, "Remediation of Hearing Loss," at the Institute of Hearing and Speech, in Kajetany-Warsaw, Poland (2006-2010; this project is supported by the European Commission).

Consultant to the President of India, His Excellency Dr. A.P.J. Kalam, on remediation of hearing loss in that country (March 2006).

Principal outside reviewer for an effort to develop an indigenous cochlear implant system for manufacture and widespread application in India (2005-2007).

Visiting Professor, University of Technology, Sydney, October 2011.

Visiting Professor, University of Illinois, Urbana-Champaign, IL, February 2007.

Visiting Professor, University of Toronto, February 2005.

Election to Sigma Xi, the scientific honorary society, October 29, 2004.

Member of the International Scientific Advisory Board for the International Center of Hearing and Speech, Kajetany (near Warsaw), Poland (2003-present).

Consultant and principal outside reviewer for an effort at Seoul National University to develop a low cost but nonetheless highly effective cochlear implant system for use in low- and mid-income countries (2002-).

Founder with Dr. Joseph C. Farmer, Jr., and others of the Cochlear Implant Program at Duke (1984).

Member of the core committee (of four) to develop a comprehensive Hearing Center at Duke (2003-2008).

Member of the Outreach Faculty for the Engineering Research Center (ERC) for Wireless Integrated Microsystems, at the University of Michigan (2000-present). (The Center is supported as one of approximately 20 ERCs by the NSF; one key goal of the Center at the University of Michigan is to develop a fully implantable auditory prosthesis.)

Member of the External Scientific Advisory Committee for the W.M. Keck Foundation Neural Prosthesis Research Center, located in Boston, MA (1999-2003).

Member of the oversight committees for Program Project Grants on cochlear implants at the Kresge Hearing Research Institute, University of Michigan (1987-1995), and at the University of Iowa (1994-1995).

Co-Investigator for two projects in the Program Project Grant on cochlear implants at the University of Iowa (1995-2000); the projects included the Audiology and Electrophysiology projects within the PPG, with Richard Tyler serving as the PI for the Audiology project and Paul Abbas serving as the PI for the Electrophysiology project).

Co-investigator for a Duke Institute for Brain Sciences (DIBS) incubator award on “Feasibility studies of the inferior colliculus as a prosthetic site” (2009-2010; the other investigators include Nell Cant, Warren Grill, Jennifer Groh, and Debara Tucci).

Member of the Science Advisory Council for the House Ear Institute, Los Angeles, CA (1990).

Member of a team of five North American experts invited by the Chinese government to assist in the specification and development of an inexpensive yet effective cochlear implant system for widespread use in that country (1993).

Reviewer of grant and contract applications for the NIH, NSF, DVA, MRC (Canada), MRC (UK), Swiss National Science Foundation, Austrian Science Fund, Action on Hearing Loss (UK), and the Wellcome Trust (UK), including service as the Chair of a review committee for the NIH.

Member of site visit teams to evaluate program project and single grant applications in the areas of cochlear prostheses (for the NIH), hearing aids (NIH), and biological effects of non-ionizing radiation (DVA).

Invited guest scientist at the Coleman Memorial Laboratory, University of California at San Francisco (various times in the years 1983-1986).

Member of the NIDCD/DVA Advisory Committee on Hearing Aid Research and Development (1993-1996).

Member of the Subcommittee on Microwave and Laser Exposure, North Carolina Radiation Protection Commission (1981-1986)

Chair of sessions or focus groups at 34 international conferences since 1987.

Invited speaker for the NIH Consensus Development Conference on Cochlear Implants, May 2-4, 1988; member of the planning committee for the 1995 NIH Consensus Development Conference on Cochlear Implants in Adults and Children; and invited speaker at that Conference, May 15-17, 1995.

Keynote, Guest of Honor (GOH), or named Distinguished Speaker at 49 international conferences and at three national conferences (in the UK, South Korea, and the USA). (The GOH and some of the named speeches also are noted in the preceding section on “Major Awards and Honors.”)

Invited speaker at more than 160 other national and international conferences.

Faculty member for many continuing-education courses on cochlear implants.

Consultant for the past 3+ decades for many NIH projects on cochlear implants and related topics.

Senior Member of the IEEE and the IEEE Engineering in Medicine and Biology Society (Wilson was promoted from the Member grade to the Senior Member grade in April 2006).

Member of the Acoustical Society of America, American Association for the Advancement of Science, the New York Academy of Sciences, the Association for Research in Otolaryngology, and Sigma Xi.

Member of Steering Committees for the biennial *Conference on Implantable Auditory Prostheses* for the years 1987, 1989, 1993, 1995, 1997, 1999, 2001, 2003 and 2005.

Member of the Planning Committee for the *Vth International Cochlear Implant Conference*, New York, NY, 1997.

Member of the Steering Committee for the *VIII International Cochlear Implant Conference*, Indianapolis, IN, May 10-13, 2004.

Member of the Faculty Board for the *7th European Symposium on Paediatric Cochlear Implantation*, Geneva, Switzerland, May 2-5, 2004.

Member of the Faculty Board for more than 100 other conferences on cochlear implants and related topics.

Organizer (with Professors Rainer Klinke, Ph.D, and Rainer Hartmann, Ph.D.) of a special one-day symposium on *Future Directions for the Further Development of Cochlear Implants*, Frankfurt, Germany, October 15, 2003.

Co-Organizer (with Prof. Henryk Skarżyński, M.D., Ph.D.) of the *Fourth Hearing Preservation Workshop*, Warsaw-Kajetany, Poland, October 2005.

Co-Organizer (with Donald K. Eddington, Ph.D.) of a special retreat on *Future Directions for Cochlear Implants*, Boston, MA, March 17-19, 2006.

Co-Organizer (with Peter S. Roland, M.D.) of a special meeting on *The Future of Cochlear Implants: Roles of the Brain in Implant Outcomes and Design*, Dallas, TX, August 17, 2007.

Organizer (with Debara Tucci, M.D.) of the Grand Opening of the Duke Hearing Center, with a keynote speech by Prof. Michael M. Merzenich of the University of California at San Francisco, Durham, NC, January 29, 2009.

Organizer (with Dale Purves, M.D.) of a special Roundtable in honor of Prof. Michael M. Merzenich, on *A 'Top-Down' or 'Cognitive Neuroscience' Approach to Cochlear Implant Designs*, Durham, NC, January 30, 2009.

Organizer (with David Fitzpatrick, Ph.D., Elizabeth Johnson, Ph.D., and Debara Tucci, M.D.) of a Duke Institute for Brain Sciences (DIBS) “Transcending the Boundaries” Workshop on *Listening with the Brain: New Approaches to Optimizing the Effectiveness of Cochlear Prosthetics*, Durham, NC, February 26-27, 2010.

Organizer (with Eva Karltorp, M.D., and Josef Miller, Ph.D.) of a Special Symposium on “The Listening Brain” at the 11th *International Conference on Cochlear Implants and Other Auditory Implantable Technologies*, held in Stockholm, Sweden, June 30 through July 3, 2010.

Organizer (with Emily Tobey, Ph.D., and Peter Roland, M.D.) of a Workshop on *Brain Centric Considerations for Cochlear Implantation*, held in Dallas, TX, August 27, 2012.

Co-Organizer (with Jane Opie, Ph.D., Christoph von Ilberg, M.D., and René Gifford, Ph.D.) of a Conference on *Hearing Implants for Older Adults*, held in New York City, January 16-18, 2014.

Member of the Duke Cornerstone Society, recognizing 30+ years of continuous financial support for the University.

Editorial Positions and Service as a Reviewer for Journals

Member of the inaugural editorial board of *Cochlear Implants International*, the first international, peer-reviewed journal devoted to cochlear implants (2000-present).

Member of the International Advisory Board for the *Journal of Hearing Science* (2011-present).

Member of the editorial board for the *International Journal of Otolaryngology* (2011-present).

Reviewer for the following journals: *Journal of the Acoustical Society of America*; *Journal of Speech & Hearing Research*; *Audiology*; *Hearing Research*; *American Journal of Otology*; *Otology & Neurotology*; *Annals of Otology, Rhinology & Laryngology*; *Ear & Hearing*; *ORL – Journal for Oto-Rhino-Laryngology, Head and Neck Surgery*; *British Journal of Audiology*; *Cochlear Implants International*; *International Journal of Pediatric Otorhinolaryngology*; *Canadian Medical Association Journal*; *Audiology & Neuro-otology*; the *Journal of Neural Engineering*; the *Anatomical Record*; the *IEEE Transactions on Biomedical Engineering*, and *Nature Scientific Reports*, among others.

Areas of Research and Special Interest

Cochlear implants; auditory neuroscience; auditory physiology; speech processing and analyses; speech production and reception; mathematical modeling of physiological systems; design of auditory prostheses; design of neural prostheses; cognitive hearing science

Funding History

This section lists projects directed by Blake Wilson, in reverse chronological order. He has supervised many other projects, in his roles as the Head of the Neuroscience Program and later as the Director of the Center for Auditory Prosthesis Research at RTI, that are not listed here. The total of awards to

Wilson during his time as an active employee at RTI was \$13.2 million (24 projects), in the US dollar valuations at the times of the projects. He now is a Senior Fellow Emeritus at RTI, and also is working for, or on behalf of, other organizations that fund projects internally or receive partial funding for projects from the European Commission. These latter projects are not listed below.

Period	Sponsor & Number	Title	Amount
2002-6	NIH N01-DC-2-1002	Speech processors for auditory prostheses	2,670,606
1999-2001	Cochlear Corp.	Engineering assistance in the further development of cochlear implants	150,000
1998-2002	NIH N01-DC-8-2105	Speech processors for auditory prostheses	2,499,860
1998	Advanced Bionics Corp.	Engineering assistance in the further development of speech processing strategies, highly-selective electrodes, and objective measures for fitting cochlear implants	100,000
1995-2000	University of Iowa (subcontract from NIH P50 DC00242)	Provide support as a Co-Investigator for two projects within the U. Iowa PPG on cochlear implants	170,037
1995-8	NIH N01-DC-5-2103	Speech processors for auditory prostheses	2,317,556
1992-5	NIH N01-DC-2-2401	Speech processors for auditory prostheses	1,507,453
1991-3	Advanced Bionics Corp.	Design and evaluation of the Clarion cochlear prosthesis	150,146
1991	NIH/NIDCD	Support for the 1991 Conference on Implantable Auditory Prostheses	10,000
1990-5	Duke University (subcontract from NIH P01-DC00036)	Ensemble neural responses to intracochlear electrical stimulation (Project IV of an NIH PPG on "Mechanisms of intracochlear electrical stimulation")	402,908
1989-92	NIH N01-DC-9-2401	Speech processors for auditory prostheses	1,278,856
1988-9	Research Triangle Institute (Professional Development Award)	Collaborative studies with investigators at the University of Frankfurt (J.W. Goethe Universität), to elucidate mechanisms of neural encoding with cochlear implants	13,730
1985-9	NIH N01-NS-5-2396	Speech processors for auditory prostheses	1,019,988
1984-7	Storz Instrument Co.	Evaluate the efficacy of single-channel coding strategies for extra-cochlear auditory prostheses	160,000
1983-5	NIH N01-NS-3-2356	Speech processors for auditory prostheses	397,926
1983-4	Research Triangle Institute (Professional Development Award)	Participate in an expedition sponsored by the National Geographic Society, to elucidate the acoustic basis of prey recognition by Mustache bats	10,284
1981	NIH PR-048281	Auditory nerve simulator	4,679
1979-83	EPA 68-02-3276	Identification of sites in brain tissue affected by non-ionizing electromagnetic radiation	156,681
1979-81	NIH N01-ES-9-008	Investigations to determine the peripheral and central receptors mediating effects of microwave radiation on brain activity	94,268
1978-9	VA, various #'s	Develop computer models of blood flow dynamics in the healthy human leg and in legs in which femoro-popliteal bypass grafts have been inserted	13,800
1977	Research Triangle Institute (Professional Development Award)	Speech encoders for cochlear implant prostheses	5,866
1976-7	Monitor, Inc.	Computerized audiometer software	17,751

1976-7	NIH PD-151468-7	Evaluate the efficacy of [¹⁴ C]-2-deoxy-D-glucose autoradiography for mapping brain responses to microwave radiation	10,000
1975	EPA 68-02-2231	Auditory neural response to low-power pulsed microwave irradiation: A pilot study	18,985

Peer-Reviewed Publications

1. Wright D, Hebrank JH, Wilson BS: Pinna reflections as cues for localization. *J Acoust Soc Am* 56: 957-962, 1974.
2. Wilson BS, Scott SM: Hemodynamic design considerations for an improved artery shunt prosthesis. In DJ Schneck (Ed.), *Bio-Fluid Mechanics*, VPI Press, Blacksburg, VA, 1978, pp. 93-98.
3. Scott SM, Wilson BS: The mechanical design of vascular prostheses. In P Puel, H Boccalon and A Enjalbert (Eds.), *Hemodynamics of the Limbs*, Institut National de la Sante et de la Recherche Medicale, Paris, 1979, pp. 251-259.
4. Wilson BS, Zook JM, Joines WT, Casseday JH: Alterations in activity at auditory nuclei of the rat induced by exposure to microwave radiation: Autoradiographic evidence using [¹⁴C]-2-deoxy-D-glucose. *Brain Res* 187: 291-306, 1980.
5. Joines WT, Wilson BS: Field-induced forces at dielectric interfaces as a possible mechanism of rf hearing effects. *Bull Math Biol* 43: 401-413, 1981.
6. Kobler JB, Wilson BS, Henson OW Jr., Bishop AL: Echo intensity compensation by echolocating bats. *Hear Res* 20: 99-108, 1985.
7. Wilson BS, Joines WT: Mechanisms and physiologic significance of microwave action on the auditory system. *J Bioelect* 4: 495-525, 1985.
8. Henson OW Jr., Bishop A, Keating A, Kobler J, Henson M, Wilson B, Hansen R: Biosonar imaging of insects by *Pteronotus p. parnellii*, the Mustached bat. *National Geographic Res* 3: 82-101, 1987.
9. Wilson BS, Finley CC, Farmer JC Jr., Lawson DT, Weber BA, Wolford RD, Kenan PD, White MW, Merzenich MM, Schindler RA: Comparative studies of speech processing strategies for cochlear implants. *Laryngoscope* 98: 1069-1077, 1988.
10. Wilson BS, Schindler RA, Finley CC, Kessler DK, Lawson DT, Wolford RD: Present status and future enhancements of the UCSF cochlear prosthesis. In P Banfai (Ed.), *Cochlear Implants: Current Situation*, Rudolf Bermann GmbH, Erkelenz, Germany, 1988, pp. 395-427.
11. Wilson BS (moderator), Dent LJ, Dillier N, Eddington DK, Hochmair-Desoyer IJ, Pfingst BE, Patrick J, Sürth W, Walliker J: Round table discussion on speech coding. In P Banfai (Ed.), *Cochlear Implants: Current Situation*, Rudolf Bermann GmbH, Erkelenz, Germany, 1988, pp. 693-704.
12. Wilson BS, Finley CC, Lawson DT, Wolford RD: Speech processors for cochlear prostheses. *Proc IEEE* 76: 1143-1154, 1988.
13. Kohut RI, Carney AE, Eviatar L, Green DM, Hind JE, Hinojosa R, Levitt H, Miller KD, Mills JH, Rockette HE, Rybak LP, Schwartz IR, Stark RE, Thompson SJ, Bilger RC, Boothroyd A, Cohen NL, Eddington DK, Gantz BJ, Hambrecht FT, Jerger J, Knutson JF, Lansing CR, Linthicum FH Jr, Mecklenburg DJ, Miller JM, Miyamoto RT, Osberger MJ, Rabinowitz WM, Rosen S, Ruben RJ, Shannon RV, Simmons FB, Somers MN, Tong YC, van den Honert C, Wilson BS, Elkins E, Bernstein MJ, Black FO, Clark SM, Duncan P, Elliott JM, Hill JG, Jakubczak LF, Kavanagh, JF, Naunton RF, Shakhshiri ZA, Yin L, Young ED: Cochlear implants. *NIH Consens Statement* 7(2): 1-25, 1988. (This Statement also was published in the *Arch Otolaryngol Head Neck Surg* 115: 31-36, 1989, and in the *Int J Technol Assess Health Care* 5: 288-297, 1989.)
14. Finley CC, Wilson BS, White MW: Models of neural responsiveness to electrical stimulation. In JM Miller and FA Spelman (Eds.), *Cochlear Implants: Models of the Electrically Stimulated Ear*, Springer-Verlag, 1990, pp. 55-96.

15. Wilson BS, Finley CC, Lawson DT: Representations of speech features with cochlear implants. In JM Miller and FA Spelman (Eds.), *Cochlear Implants: Models of the Electrically Stimulated Ear*, Springer-Verlag, 1990, pp. 339-376.
16. Wilson BS, Lawson DT, Finley CC, Wolford RD: Coding strategies for multichannel cochlear prostheses. *Am J Otol* 12 (Suppl. 1): 56-61, 1991.
17. Wilson BS, Finley CC, Lawson DT, Wolford RD, Eddington DK, Rabinowitz WM: Better speech recognition with cochlear implants. *Nature* 352: 236-238, 1991. (This paper is the most highly cited publication in the specific field of cochlear implants and has been since the end of 1999. At present, it has more than 560 citations according to the Web of Science.)
18. Wilson BS: Signal processing. In R Tyler (Ed.), *Cochlear Implants: Audiological Foundations*, Singular Publishing Group, San Diego, CA, 1993, pp. 35-85.
19. Wilson BS, Lawson DT, Finley CC, Wolford RD: Importance of patient and processor variables in determining outcomes with cochlear implants. *J Speech Hear Res* 36: 373-379, 1993.
20. Lawson DT, Wilson BS, Finley CC: New processing strategies for multichannel cochlear prostheses. *Prog Brain Res* 97: 313-321, 1993.
21. Wilson BS, Finley CC, Lawson DT, Wolford RD, Zerbi M: Design and evaluation of a continuous interleaved sampling (CIS) processing strategy for multichannel cochlear implants. *J Rehab Res Devel* 30: 110-116, 1993.
22. Wilson BS, Lawson DT, Zerbi M, Finley CC: Recent developments with the CIS strategies. In IJ Hochmair-Desoyer and ES Hochmair (Eds.), *Advances in Cochlear Implants*, Verlag Manz, Vienna, 1994, pp. 103-112.
23. Wilson BS, Lawson DT, Zerbi M, Finley CC, Wolford RD: New processing strategies in cochlear implantation. *Am J Otol* 16: 669-675, 1995.
24. Wilson BS, Lawson DT, Zerbi M: Advances in coding strategies for cochlear implants. *Adv Otolaryngol Head Neck Surg* 9: 105-129, 1995.
25. Gates GA, Daly K, Dichtel WJ, Dooling RJ, Gulya AJ, Hall JW, Jerger SW, Jones JE, Mayer MH, Pierschalla M, Ross LF, Schwartz RG, Weinstein BE, Young ED, Abbas PJ, Blamey P, Brackmann DE, Brimacombe JA, Chute PM, Cohen NL, Dorman MF, Eddington DK, Gantz BJ, Heller JW, Ketten DR, Knutson JF, Leake PA, McDermott HJ, Miyamoto RT, Moog JS, Osberger MJ, Shannon RV, Skinner MW, Summerfield Q, Tobey EA, Wilson BS, Zwolan TA, Donahue AH, Allen MP, Beck LB, Bray EA, Cooper JA, Ferguson JH, Flack MN, Hall WH, Hambrecht FT, Krasnegor N, Monjan AA, Naunton RF: Cochlear implants in adults and children. *NIH Consens Statement* 13(2): 1-30, 1995. (The Statement also was published in the *JAMA* 274: 1955-1961, 1995.)
26. Wilson BS: Thirty years of the *British Journal of Audiology*: Guest Editorial: The future of cochlear implants. *Brit J Audiol* 31: 205-225, 1997.
27. Lawson DT, Wilson BS, Finley CC, Zerbi M, Cartee LA, Roush PA, Farmer JC Jr., Tucci DL: Cochlear implant studies at Research Triangle Institute and Duke University Medical Center. *Scand Audiol* 26 (Suppl. 46): 50-64, 1997.
28. Wilson BS, Finley CC, Lawson DT, Zerbi M: Temporal representations with cochlear implants. *Am J Otol* 18: S30-34, 1997.
29. Wilson BS, Rebscher S, Zeng F-G, Shannon RV, Loeb GE, Lawson DT, Zerbi M: Design for an inexpensive but effective cochlear implant. *Otolaryngol Head Neck Surg* 118: 235-241, 1998.
30. Lawson DT, Wilson BS, Zerbi M, van den Honert C, Finley CC, Farmer JC Jr., McElveen JT, Roush PA: Bilateral cochlear implants controlled by a single speech processor. *Am J Otol* 19: 758-761, 1998.
31. Rubinstein JT, Wilson BS, Finley CC, Abbas PJ: Pseudospontaneous activity: Stochastic independence of auditory nerve fibers with electrical stimulation. *Hear Res* 127: 108-118, 1999.
32. Wilson BS: New directions in implant design. In *Cochlear Implants*, edited by SB Waltzman and N Cohen, Thieme Medical and Scientific Publishers, New York, NY, 2000, pp. 43-56.
33. Tucci DL, Roush PA, Lawson DT, Wilson BS, Zerbi M, Farmer JC Jr.: Surgical experience with the modified percutaneous Nucleus cochlear implant. In *Cochlear Implants*, edited by SB Waltzman and N Cohen, Thieme Medical and Scientific Publishers, New York, NY, 2000, pp. 167-169.

34. Tyler RS, Parkinson A, Wilson BS, Parkinson W, Lowder M, Witt S, Rubinstein J, Gantz B: Evaluation of different choices of n in an n -of- m processor for cochlear implants. *Adv Oto-Rhino-Laryngol* 57: 311-315, 2000.
35. Niparko JK, Wilson BS: History of cochlear implants. In *Cochlear Implants: Principles & Practices*, edited by JK Niparko, KI Kirk, NK Mellon, AM Robbins, DL Tucci and BS Wilson, Lippincott Williams & Wilkins, Philadelphia, PA, 2000, pp. 103-107.
36. Wilson BS: Cochlear implant technology. In *Cochlear Implants: Principles & Practices*, edited by JK Niparko, KI Kirk, NK Mellon, AM Robbins, DL Tucci and BS Wilson, Lippincott Williams & Wilkins, Philadelphia, PA, 2000, pp. 109-119.
37. Wilson BS: Strategies for representing speech information with cochlear implants. In *Cochlear Implants: Principles & Practices*, edited by JK Niparko, KI Kirk, NK Mellon, AM Robbins, DL Tucci and BS Wilson, Lippincott Williams & Wilkins, Philadelphia, PA, 2000, pp. 129-170.
38. Tyler RS, Gantz BJ, Rubinstein JT, Wilson BS, Parkinson AJ, Wolaver AA, Preece JP, Witt S, Lowder MW: Three-month results with bilateral cochlear implants. *Ear Hear* 23: 80S-89S, 2002.
39. Tyler RS, Parkinson AJ, Wilson BS, Witt S, Preece JP, Noble W: Patients utilizing a hearing aid and a cochlear implant: Speech perception and localization. *Ear Hear* 23: 98-105, 2002.
40. Tyler RS, Preece JP, Wilson BS, Rubinstein JT, Parkinson AJ, Wolaver AA, Gantz BJ: Distance, localization and speech perception pilot studies with bilateral cochlear implants. In *Cochlear Implants – An Update*, edited by T Kubo, Y Takahashi and T Iwaki, Kugler Publications, The Hague, The Netherlands, 2002, pp. 517-521.
41. Loeb GE, Wilson BS: Prosthetics, Sensory systems. In *Handbook of Brain Theory and Neural Networks*, 2nd edition, edited by MA Arbib, MIT Press, Cambridge, MA, 2003, pp. 926-929.
42. Wilson BS, Lawson DT, Müller JM, Tyler RS, Kiefer J: Cochlear implants: Some likely next steps. *Annu Rev Biomed Eng* 5: 207-249, 2003.
43. Wilson BS: Engineering design of cochlear implants. In *Cochlear Implants: Auditory Prostheses and Electric Hearing*, edited by F-G Zeng, AN Popper and RR Fay, Springer-Verlag, New York, 2004, pp. 14-52. (This book is Volume 20 in the highly acclaimed *Springer Handbook of Auditory Research*, and also may be cited as Wilson BS, SHAR 20: 14-52.)
44. Loeb GE, Wilson BS: Cochlear prosthesis. In Adelman G, Smith BH (eds.), *Encyclopedia of Neuroscience*, 3rd edition. Amsterdam: Elsevier, 2004. (The *Encyclopedia* is available both in book and CD-ROM formats.)
45. Wilson BS, Sun X, Schatzer R, Wolford RD: Representation of fine-structure or fine-frequency information with cochlear implants. *Int Cong Ser* 1273: 3-6, 2004.
46. Dorman MF, Wilson BS: The design and function of cochlear implants. *Am Scientist* 92: 436-445, 2004.
47. Wilson BS, Schatzer R, Lopez-Poveda EA, Sun X, Lawson DT, Wolford RD: Two new directions in speech processor design for cochlear implants. *Ear Hear* 26: 73S-81S, 2005.
48. Wilson BS: Speech processing strategies. In *Cochlear Implants: A Practical Guide, 2nd Edition*, edited by HR Cooper and LC Craddock, Whurr, London and Philadelphia, 2006, pp. 21-69. (Whurr Publishers Ltd. is a subsidiary of John Wiley & Sons Ltd.)
49. Wilson BS, Schatzer R, Lopez-Poveda EA: Possibilities for a closer mimicking of normal auditory functions with cochlear implants. In *Cochlear Implants, 2nd Edition*, edited by SB Waltzman and JT Roland, Jr, Thieme Medical Publishers, New York, 2006, pp. 48-56.
50. Loeb GE, Wilson BS: Cochlear prosthesis. In Adelman G, Smith BH (eds.), *Encyclopedia of Neuroscience*, 4th edition. Amsterdam: Elsevier, 2007. (The *Encyclopedia* is available both in book and CD-ROM formats; this paper in the 4th Edition is a substantially revised and updated version of the paper in the 3rd Edition, ref. 42 above.)
51. Wilson BS, Dorman MF: The surprising performance of present-day cochlear implants. *IEEE Trans Biomed Eng* 54: 969-972, 2007.
52. An SK, Park SI, Jun SB, Byun KM, Lee CJ, Wilson BS, Rebscher SJ, Kim SJ: Design for a simplified cochlear implant system. *IEEE Trans Biomed Eng* 54: 973-982, 2007.

53. Buss E, Pillsbury HC, Buchman CA, Pillsbury CH, Clark MS, Haynes DS, Labadie RF, Amberg S, Roland PS, Kruger P, Novak MA, Wirth JA, Black JM, Peters R, Lake J, Wackym PA, Firszt JB, Wilson BS, Lawson DT, Schatzer R, D'Haese PSC, Barco AL: Multi-center US bilateral MED-EL cochlear implantation study: Speech perception over the first year of use. *Ear Hear* 29: 20-32, 2008.
54. Wilson BS, Dorman MF: Interfacing sensors with the nervous system: Lessons from the development and success of cochlear implants. *IEEE Sensors J* 8: 131-147, 2008.
55. Wilson BS, Dorman MF: Cochlear implants: A remarkable past and a brilliant future. *Hear Res* 242: 3-21, 2008. (This paper is the lead article in the special issue on *Frontiers of Auditory Prosthesis Research: Implications for Clinical Practice*, edited by Guest Editor Bryan Pfungst. The paper also has been among the most heavily downloaded articles from the Hearing Research web site. The article has been number 1, 1, 2, 4, 1, 2, 2, 5, 2, 3, 4, 11, 4, 8, 6, 16, 5, 6, 5, 11, and 8 on the download list in the 21 quarters beginning with the October-to-December 2008 quarter.)
56. Wilson BS, Dorman MF: Cochlear implants: Current designs and future possibilities. *J Rehab Res Devel* 45: 695-730, 2008. (This paper is a feature article in the special issue on *Cochlear Implants*, edited by Guest Editor Harry Levitt. The paper also was the most heavily downloaded article from the journal's web site for a substantial part of 2011.)
57. Wilson BS, Dorman MF: The design of cochlear implants. In *Cochlear Implants: Principles & Practices, Second Edition*, edited by JK Niparko, KI Kirk, NK Mellon, AM Robbins, DL Tucci, and BS Wilson, Lippincott Williams & Wilkins, Philadelphia, PA, 2009, pp. 95-135.
58. Wilson BS, Dorman MF: Stimulation for the return of hearing. In: *Neuromodulation: A Comprehensive Handbook*, edited by Ali Rezai, Elliot Krames, and Hunter Peckham. Amsterdam: Elsevier, 2009, pp. 713-722.
59. Loeb GE, Wilson BS: Cochlear prosthesis. In: *Encyclopedia of Neuroscience*, edited by Larry R Squire (Editor in Chief). Amsterdam: Elsevier, 2009, pp. 1051-1054.
60. Wilson BS, Lopez-Poveda EA, Schatzer R: Use of auditory models in developing coding strategies for cochlear implants. In: *Computational Models of the Auditory System*, edited by R Meddis, EA Lopez-Poveda, A Popper, and RR Fay. Springer-Verlag, New York, 2010, pp. 237-260. (This book is another volume in the highly acclaimed *Springer Handbook of Auditory Research*, and also may be cited as Wilson et al., SHAR 35: 237-260.)
61. Tucci DL, Merson MH, Wilson BS: A summary of the literature on global hearing impairment: Current status and priorities for action. *Otol Neurotol* 31: 31-41, 2010.
62. Tyler RS, Witt SA, Dunn CC, Perreau A, Parkinson AJ, Wilson BS: An attempt to improve bilateral cochlear implants by increasing the distance between electrodes and providing complementary information to the two ears. *J Am Acad Audiol* 21: 52-65, 2010.
63. McElveen JT Jr, Blackburn EL, Green JD Jr, McLear PW, Thimsen DJ, Wilson BS: Remote programming of cochlear implants: A telecommunications model. *Otol Neurotol* 31: 1035-1040, 2010.
64. Wilson BS: Partial deafness cochlear implantation (PDCI) and electric-acoustic stimulation (EAS). *Cochlear Implants Int* 11 (Suppl 1): 56-66, 2010. (This paper is an invited keynote article for a special issue of the journal.)
65. Dorman MF, Yost WA, Wilson BS, Gifford RH: Speech perception and sound localization by adults with bilateral cochlear implants. *Semin Hear* 32: 73-102, 2011.
66. Wilson BS: A 'top down' or 'cognitive neuroscience' approach to cochlear implant designs and fittings. *Cochlear Implants Int* 12: S35-S39, 2011.
67. Wilson BS, Dorman MF: Remediation of severe or total losses of hearing with cochlear implants. In *Usher Syndrome: Pathogenesis, Diagnosis and Therapy*, edited by S Ahuja. Nova Science Publishers, Hauppauge, NY, pp. 327-345, 2011.
68. Wilson BS, Dorman MF, Woldorff MG, Tucci DL: Cochlear implants: Matching the prosthesis to the brain and facilitating desired plastic changes in brain function. *Prog Brain Res* 194: 117-129, 2011.
69. Wilson BS: Retrospective valuations of intellectual property. *J Technology Transfer* 37: 124-133, 2012 (epub ahead of print was on 27 May 2010 [DOI: 10.1007/s10961-010-9172-9]).

70. Wilson BS, Dorman MF: Signal processing strategies for cochlear implants. In *Cochlear Implants and Other Implantable Hearing Devices*, edited by MJ Ruckenstein. Plural Publishing, San Diego, CA, pp. 51-84, 2012.
71. Wilson BS, Dorman MF: Overview. In *Better Hearing with Cochlear Implants: Studies at the Research Triangle Institute*, edited by BS Wilson and MF Dorman. Plural Publishing, San Diego, CA, pp. 1-20, 2012. (This and the next 20 publications are from the book *Better Hearing with Cochlear Implants*.)
72. Wilson BS, Finley CC, Lawson DT: Comparison of analog and pulsatile coding strategies for multichannel cochlear prostheses. In *Better Hearing with Cochlear Implants: Studies at the Research Triangle Institute*, edited by BS Wilson and MF Dorman. Plural Publishing, San Diego, CA, pp. 27-58, 2012.
73. Wilson BS, Finley CC, Lawson DT: New levels of speech reception with cochlear implants. In *Better Hearing with Cochlear Implants: Studies at the Research Triangle Institute*, edited by BS Wilson and MF Dorman. Plural Publishing, San Diego, CA, pp. 59-68, 2012.
74. Wilson BS, Finley CC, Lawson DT: Evaluation of alternative implementations of the continuous interleaved sampling (CIS), interleaved pulses (IP), and peak picker (PP) processing strategies. In *Better Hearing with Cochlear Implants: Studies at the Research Triangle Institute*, edited by BS Wilson and MF Dorman. Plural Publishing, San Diego, CA, pp. 69-89, 2012.
75. Wilson BS, Finley CC, Lawson DT: Comparison of compressed analog (CA) and continuous interleaved sampling (CIS) processors in tests with seven Ineraid subjects. In *Better Hearing with Cochlear Implants: Studies at the Research Triangle Institute*, edited by BS Wilson and MF Dorman. Plural Publishing, San Diego, CA, pp. 91-118, 2012.
76. Wilson BS, Lawson DT, Finley CC, Zerbi M: Evaluation of other promising strategies. In *Better Hearing with Cochlear Implants: Studies at the Research Triangle Institute*, edited by BS Wilson and MF Dorman. Plural Publishing, San Diego, CA, pp. 119-128, 2012.
77. Wilson BS, Lawson DT, Zerbi M, Finley CC: Completion of “poor performance” series. In *Better Hearing with Cochlear Implants: Studies at the Research Triangle Institute*, edited by BS Wilson and MF Dorman. Plural Publishing, San Diego, CA, pp. 129-140, 2012.
78. Wilson BS, Lawson DT, Zerbi M, Finley CC: Auditory brainstem implant (ABI) studies. In *Better Hearing with Cochlear Implants: Studies at the Research Triangle Institute*, edited by BS Wilson and MF Dorman. Plural Publishing, San Diego, CA, pp. 141-145, 2012.
79. Wilson BS, Lawson DT, Zerbi M, Finley CC: Virtual channel interleaved sampling (VCIS) processors: initial studies with subject SR2. In *Better Hearing with Cochlear Implants: Studies at the Research Triangle Institute*, edited by BS Wilson and MF Dorman. Plural Publishing, San Diego, CA, pp. 147-155, 2012.
80. Wilson BS, Zerbi M, Lawson DT: Identification of virtual channels on the basis of pitch. In *Better Hearing with Cochlear Implants: Studies at the Research Triangle Institute*, edited by BS Wilson and MF Dorman. Plural Publishing, San Diego, CA, pp. 157-163, 2012.
81. Wilson BS, Lawson DT, Zerbi M: Further evaluation of VCIS processors. In *Better Hearing with Cochlear Implants: Studies at the Research Triangle Institute*, edited by BS Wilson and MF Dorman. Plural Publishing, San Diego, CA, pp. 165-178, 2012.
82. Wilson BS, Lawson DT, Zerbi M, Finley CC: Design for an inexpensive but nonetheless highly effective cochlear implant system. In *Better Hearing with Cochlear Implants: Studies at the Research Triangle Institute*, edited by BS Wilson and MF Dorman. Plural Publishing, San Diego, CA, pp. 179-181, 2012.
83. Lawson DT, Wilson BS, Zerbi M, Finley CC: 22 electrode percutaneous study: results for the first five subjects. In *Better Hearing with Cochlear Implants: Studies at the Research Triangle Institute*, edited by BS Wilson and MF Dorman. Plural Publishing, San Diego, CA, pp. 183-211, 2012.
84. Lawson DT, Wilson BS, Zerbi M, Finley CC: Speech reception with bilateral cochlear implants. In *Better Hearing with Cochlear Implants: Studies at the Research Triangle Institute*, edited by BS Wilson and MF Dorman. Plural Publishing, San Diego, CA, pp. 217-239, 2012.
85. Wolford RD, Lawson DT, Schatzer R, Sun X, Wilson BS: Sensitivities to interaural timing differences. In *Better Hearing with Cochlear Implants: Studies at the Research Triangle Institute*, edited by BS Wilson and MF Dorman. Plural Publishing, San Diego, CA, pp. 241-253, 2012.

86. Lawson DT, Wilson BS, Wolford RD, Sun X, Schatzer R: Pitch ranking of electrodes for 22 subjects with bilateral cochlear implants. In *Better Hearing with Cochlear Implants: Studies at the Research Triangle Institute*, edited by BS Wilson and MF Dorman. Plural Publishing, San Diego, CA, pp. 255-269, 2012.
87. Brill S, Lawson DT, Wolford RD, Wilson BS, Schatzer R: Psychophysical studies relating to combined EAS. In *Better Hearing with Cochlear Implants: Studies at the Research Triangle Institute*, edited by BS Wilson and MF Dorman. Plural Publishing, San Diego, CA, pp. 275-305, 2012.
88. Wilson BS, Wolford RD, Lawson DT, Schatzer R: Speech reception with combined EAS. In *Better Hearing with Cochlear Implants: Studies at the Research Triangle Institute*, edited by BS Wilson and MF Dorman. Plural Publishing, San Diego, CA, pp. 307-325, 2012.
89. Wilson BS, Lawson DT, Zerbi M, Finley CC: Temporal representations with cochlear implants. In *Better Hearing with Cochlear Implants: Studies at the Research Triangle Institute*, edited by BS Wilson and MF Dorman. Plural Publishing, San Diego, CA, pp. 331-344, 2012.
90. Wilson BS, Finley CC, Zerbi M, Lawson DT: Strategies for the repair of deficits in temporal representations with cochlear implants. In *Better Hearing with Cochlear Implants: Studies at the Research Triangle Institute*, edited by BS Wilson and MF Dorman. Plural Publishing, San Diego, CA, pp. 345-359, 2012.
91. Wilson BS, Finley CC, Zerbi M, Lawson DT, van den Honert C: High rate studies, subject SR2. In *Better Hearing with Cochlear Implants: Studies at the Research Triangle Institute*, edited by BS Wilson and MF Dorman. Plural Publishing, San Diego, CA, pp. 361-385, 2012.
92. Wilson BS: Treatments for partial deafness using combined electric and acoustic stimulation of the auditory system. *J Hear Sci* 2: 19-32, 2012.
93. Wilson BS: Toward better representations of sound with cochlear implants. *Nature Med* 19(10): 1245-1248, 2013.
94. Wilson BS, Dorman MF, Gifford RH: Cochlear implant design considerations. In *Cochlear Implants in Children: Learning and the Brain*, edited by NM Young and K Iler Kirk. Springer, New York; to be published in 2015.
95. Wilson BS: Getting a decent (but sparse) signal to the brain for users of cochlear implants. Special issue of *Hearing Research* on cochlear implants and in celebration of the 2013 Lasker-DeBakey Clinical Medical Research Award, "for the development of the modern cochlear implant, a device that bestows hearing to individuals with profound deafness." To be published in 2015.

Some Highlights from the Previously-Listed Publications

- The publication in *Nature*, reference 17, has been the most highly cited publication in the specific field of cochlear implants since the end of 1999. As of 21 February 2013, it had 505 citations according to the Web of Science (WoS) and 680 citations according to Google Scholar (GS). The next most highly cited publication in the field according to the WoS had 279 citations; its GS count was 311. (That next most highly cited publication is Otte J, Schunknecht HF, Kerr AG: Ganglion cell populations in normal and pathological human cochleae: Implications for cochlear implantation. *Laryngoscope* 88: 1231-1246, 1978.)
- The publication in the *British Journal of Audiology*, reference 26, is an invited Guest Editorial in celebration of the journal's 30th Anniversary. The paper is among the more highly cited publications in the field of cochlear implants.
- The publication in *Hearing Research*, reference 55, is the lead article in the special issue of the journal on "Frontiers of Auditory Prosthesis Research: Implications for Clinical Practice," edited by Guest Editor Bryan Pfingst. The article is among the most heavily downloaded articles from the journal's web site since the publication of the article in September 2008, including first or second on the download list for seven of the 16 quarters since the publication and in the top five on the list for all but four of the quarters. The article is the most highly cited among the 1000+ articles published in the journal during the past five years. In addition, it has the highest citations count for all articles published on the specific topic of cochlear implants during the past six years, according to the WoS and for the nearly 12,000 journals indexed by the WoS.

- The publication in the *Journal of Rehabilitation Research and Development*, reference 56, is a feature article in the special issue of the journal on “Cochlear Implants,” and was the most heavily downloaded article from the journal’s web site for a substantial part of 2011.
- Many other publications in the list also are highly cited. For example, in addition to the references 17, 26, 55, and 56 mentioned above, references 1, 6, 8, 9, 14, 21, 23, 25, 28, 30, 31, 36, 38, 39, 42, and 53 have each been cited at least 50 times according to the 21 February 2013 search using GS.
- The same search identified 59 among the 92 publications listed in the preceding section. (The 21 chapters in the book by Wilson and Dorman have not yet been included in the GS database, and 12 other publications are not included or have not yet been included in the database.) The total number of citations for those 59 publications was 2969, and the h- and g-indices were 29 and 54, respectively. The average number of citations per publication was 50.3.

Books

1. Niparko JK, Kirk KI, Mellon NK, Robbins AM, Tucci DL, Wilson BS (Eds.), *Cochlear Implants: Principles & Practices*, Lippincott Williams & Wilkins, Philadelphia, PA, 2000.
2. Niparko JK, Kirk KI, Mellon NK, Robbins AM, Tucci DL, Wilson BS (Eds.), *Cochlear Implants: Principles & Practices, Second Edition*, Lippincott Williams & Wilkins, Philadelphia, PA, 2009.
3. Wilson BS, Dorman MF: *Better Hearing with Cochlear Implants: Studies at the Research Triangle Institute*, Plural Publishing, Inc., San Diego, CA, 2012. (A review of this book by Prof. Mario Svirsky has been published in the journal *Ear and Hearing*, vol. 35, p. 137, 2014, and two additional published reviews are presented at https://www.pluralpublishing.com/publication_hcirrti.htm.)

Editorial

1. Wilson BS, Brackmann DE, Zeng F-G: Editorial – Remembering William House, DDS, MD. *Hear J* 66(2): 2, 2013.

Papers in Conference Proceedings

1. Joines WT, Wilson BS, Sharp S: Temperature-controlled heating of tumors by microwaves. In *Proc IEEE Southeastern Conf*, IEEE Press, New York, 1977, pp. 124-128.
2. Cornett RO, Beadles RL, Wilson BS: Automatic cued speech. In JM Pickett (Ed.), *Speech-Processing Aids for the Deaf*, Gallaudet Research Institute, Gallaudet College, Washington, DC, 1981, pp. 224-239.
3. Finley CC, Wilson BS, White MW: A finite-element model of bipolar field patterns in the electrically stimulated cochlea – A two-dimensional approximation. In *Proc Ninth Ann Conf Engineering in Medicine and Biology*, IEEE Press, New York, 1987, pp. 1901-1903.
4. White MW, Finley CC, Wilson BS: Electrical stimulation model of the auditory nerve: Stochastic response characteristics. In *Proc Ninth Ann Conf Engineering in Medicine and Biology*, IEEE Press, New York, 1987, pp. 1906-1907.
5. Wilson BS, Finley CC, White MW, Lawson DT: Comparisons of processing strategies for multichannel auditory prostheses. In *Proc Ninth Ann Conf Engineering in Medicine and Biology*, IEEE Press, New York, 1987, pp. 1908-1910.

Magazine Articles

1. Dorman MF, Wilson BS: Restaurer l'audition avec des implants [Restoration of hearing with implants]. *Pout la Science* 329: 68-74, 2005. (This article is a summary in French of the 2004 article in English by Dorman and Wilson published in the *American Scientist*.)
2. Wilson BS, Dorman MF: Les implants cochléaires: un passé remarquable et un brillant avenir. *Sécurité routière et surdit * 25(5): 46-49, 2012. (This article is a summary in French of the 2008 article in English by Wilson and Dorman published in *Hearing Research*.)

3. Wilson BS: The significance of the 2013 Lasker~DeBakey Clinical Medical Research Award to the field of cochlear implants and for fulfilling the mission of the American Cochlear Implant Alliance. *ACI Alliance Calling* (e-magazine) 2(1): 7, 2014. (Published by the American Cochlear Implant Alliance, McLean, VA, USA.)

Major Reports

Major reports include Quarterly Progress Reports (QPRs) and Final Reports for most of the projects listed above, under the heading of "Funding History." Only the reports in the "speech processors" series of projects are listed in this present section. Each of those 91 reports has a title of the form "Speech Processors for Auditory Protheses: Special Topic(s)." The tables below include the special topic(s) for each report. Wilson is the first author for 51 of the reports. The reports are publicly available from the United States National Institutes of Health and also are posted at <http://www.rti.org/capr/caprqrprs.html>. In addition, key sections from 18 of the reports are presented in the book by Wilson and Michael F. Dorman, *Better Hearing with Cochlear Implants: Studies at the Research Triangle Institute*, Plural Publishing, Inc., San Diego, CA, 2012.

The reports have been frequently cited in the open literature on cochlear implants and related topics. According to a search using Google Scholar, the aggregate number of citations for the reports that have been cited is 199 as of March 2012.

NIH project N01-NS-3-2356 September 26, 1983 through September 25, 1985

Report	Topic(s)	Authors
QPR 1	Development of plans for collaborative studies with UCSF; Development of tools for such studies at UCSF; Initial plans for an additional collaborative program with Duke University Medical Center	Wilson and Finley
QPR 2	Model of field patterns in the implanted cochlea; Collaboration among UCSF, Storz, DUMC and RTI; Hardware interface for communication between an Eclipse computer and patient electrodes; Design of software for a block-diagram compiler; Discussion on the possibility of recording intracochlear evoked potentials	Wilson and Finley
QPR 3	Hardware interface; Computer-based stimulator; Digital Control Unit (DCU) software for real-time communication between an Eclipse computer and stimulating hardware; Incorporation of a Frankenhauser-Huxley description of node dynamics in an integrated field-neuron model	Wilson and Finley
QPR 4	Overview of first-year effort	Wilson, Finley and Lawson
QPR 5	Further development and application of a field-neuron model	Finley and Wilson
QPR 6	Development of portable, real-time hardware; Software for support of the RTI patient stimulator; Software for support of basic psychophysical studies and speech testing; Subject testing at UCSF	Wilson, Finley and Lawson
QPR 7	Speech reception studies with a UCSF/Storz subject; Present status and functional description of the block-diagram compiler	Wilson, Finley and Lawson
QPR 8	Ensemble models of neural responses to intracochlear electrical stimulation	Wilson, Finley and Lawson
Final Report	Hardware interface; Computer-based simulator of speech processors; Integrated field-neuron model; Ensemble models of neural responses evoked by intracochlear electrical stimulation; Design of a portable speech processor; Evaluation of processing strategies in tests with a USCF patient fitted with a percutaneous connector; Reporting activity for the project	Wilson, Finley and Lawson

NIH project N01-NS-5-2396

September 26, 1985 through April 30, 1989

Report	Topic(s)	Authors
QPR 1	Psychophysical and speech reception studies with an initial DUMC/Storz percutaneous subject	Wilson, Finley and Lawson
QPR 2	Psychophysical and speech reception studies with a second DUMC/Storz percutaneous subject; Further development of an interleaved pulses (IP) processor	Wilson, Finley and Lawson
QPR 3	Initial development of a portable, real-time processor; Measurements of intracochlear electric field patterns using a percutaneous cable	Finley, Wilson and Lawson
QPR 4	Evaluation of idealized implementations of the processing strategy used in the Nucleus cochlear prosthesis	Wilson, Finley and Lawson
QPR 5	Studies of loudness and pitch perception with monopolar or radial-bipolar stimulating electrodes	Wilson, Finley and Lawson
QPR 6	Direct comparisons of analog and pulsatile coding strategies with six cochlear implant patients	Wilson, Finley and Lawson
QPR 7	A portable processor for IP processing strategies	Finley, Wilson and Lawson
QPR 8	Evaluation of two-channel "Breeuwer/Plomp" processors for cochlear implants	Wilson, Lawson and Finley
QPR 9	Studies with 6 UCSF/Storz subjects	Wilson, Finley and Lawson
QPR 10	Review of clinical trial results for 6 UCSF/Storz subjects, including learning effects with extended use	Wilson, Lawson and Finley
QPR 11	Extension of cochlear implant laboratory capabilities; Collaborative development of a next-generation auditory prosthesis	Wilson, Lawson and Finley
QPR 12	Representations of speech features with cochlear implants	Wilson, Finley and Lawson
QPR 13	Models of neural responsiveness to electrical stimulation	Finley, Wilson and Lawson
QPR 14	Binary comparisons of speech processor performance	Lawson, Wilson and Finley
Final Report	Direct comparisons of analog and pulsatile coding strategies; Design and evaluation of a two-channel "Breeuwer/Plomp" processor; Additional processor comparisons; Psychophysical studies; Development of a next-generation auditory prosthesis; Reporting activity for the project	Wilson, Finley and Lawson

NIH project N01-DC-9-2401

May 1, 1989 through July 31, 1992

Report	Topic(s)	Authors
QPR 1	Comparison of analog and pulsatile coding strategies for multichannel cochlear implants (6 UCSF/Storz subjects and 2 Ineraid subjects)	Wilson, Finley and Lawson
QPR 2	New levels of speech perception with cochlear implants; Computer interface for testing patients implanted with the Nucleus device	Wilson, Finley and Lawson
QPR 3	Evaluations of alternative implementations of CIS, IP and Peak-Picker strategies; Finite-element model of radial bipolar field patterns in the electrically stimulated cochlea	Wilson, Finley and Lawson
QPR 4	Comparison of CA and CIS processors in tests with seven Ineraid subjects	Wilson, Lawson and Finley
QPR 5	Further evaluation of CIS processors	Wilson, Finley and Lawson

QPR 6	Parametric variations and the fitting of speech processors for single-channel brainstem prostheses	Lawson, Finley and Wilson
QPR 7	A wearable speech processor platform for auditory research	Finley, Wilson, Zerbi, Hering, van den Honert and Lawson
QPR 8	Importance of patient and processor variables in determining outcomes with cochlear implants	Wilson, Lawson and Finley
QPR 9	Evaluation of a prototype for a portable processor; Evaluation of components in the MiniMed cochlear prosthesis; evaluation of automatic gain control; Preliminary studies of modulation perception; Measures of dynamic range for a variety of pulse durations and rates	Wilson, Lawson, Finley and Zerbi
QPR 10	Randomized update orders; Slow rate CIS implementations; channel number manipulations; Evaluation of other promising processing strategies; Performance of CIS and CA processors in noise; Use and possible development of new test materials	Wilson, Lawson, Finley and Zerbi
QPR 11	Efficacy of CIS processors for patients with poor clinical outcomes	Wilson, Lawson, Finley and Zerbi
QPR 12	Completion of "poor performance" series; Summary of studies with 11 Ineraid subjects; Auditory brainstem implant (ABI) studies	Wilson, Lawson, Zerbi and Finley
Final Report	Comparisons of CA and CIS processors for multichannel cochlear implants; Additional aspects of CIS performance; Evaluation of other promising strategies; Auditory brainstem implant; Record of reporting activity for the project; Suggestions for future research	Wilson, Lawson, Finley and Zerbi

NIH project N01-DC-2-2401

August 1, 1992 through July 31, 1995

Report	Topic(s)	Authors
QPR 1	Virtual channel interleaved sampling (VCIS) processors: Initial studies with subject SR2	Wilson, Lawson, Zerbi and Finley
QPR 2	Single parameter variation studies for CIS processors	Lawson, Wilson and Zerbi
QPR 3	Identification of virtual channels on the basis of pitch	Wilson, Zerbi and Lawson
QPR 4	Representation of complex tones by sound processors for implanted auditory prostheses	Lawson, Zerbi and Wilson
QPR 5	Transfer and dissemination of CIS processor technology; Parametric and control studies with CIS processors	Wilson, Lawson and Zerbi
QPR 6	Evaluation of VCIS processors	Wilson, Lawson and Zerbi
QPR 7	Temporal representations with cochlear implants: Modeling, psychophysical, and electrophysiological studies	Wilson, Finley, Zerbi and Lawson
QPR 8	Further studies of complex tone perception by implant patients	Lawson, Wilson and Zerbi
QPR 9	Strategies for the repair of distortions in temporal representations with implants	Wilson, Finley, Zerbi and Lawson
QPR 10	A channel-specific tool for analysis of consonant confusion matrices	Lawson, Wilson and Zerbi
QPR 11	Intracochlear evoked potentials for sustained electrical stimuli	Wilson, Finley, Lawson and Zerbi

Final Report	Importance of the patient variable in determining outcomes with cochlear implants; Parametric studies with CIS processors; Importance of processor fitting; “Virtual Channel” and “Sharpened Field” CIS processors; Nucleus percutaneous study; Design for an inexpensive but effective cochlear implant system; Representation of complex tones by sound processors for implanted auditory prostheses; Temporal representations with cochlear implants; Record of reporting activity for the project; Suggestions for future research	Wilson, Lawson, Zerbi and Finley
--------------	--	----------------------------------

NIH project N01-DC-5-2103

August 1, 1995 through September 29, 1998

Report	Topic(s)	Authors
QPR 1	Learning effects with extended use of CIS processors; Review of results from studies with the first subject in the 22-electrode percutaneous study; Upward extension of the CIS processed frequency spectrum	Lawson, Wilson, Zerbi and Finley
QPR 2	Manipulations in spatial representations with implants	Wilson, Lawson and Zerbi
QPR 3	22 electrode percutaneous study: Results for the first five subjects	Lawson, Wilson, Zerbi and Finley
QPR 4	New stimulator system for the speech reception laboratory	Van den Honert, Zerbi, Finley and Wilson
QPR 5	Bilateral cochlear implants controlled by a single speech processor	Lawson, Wilson, Zerbi and Finley
QPR 6	Intracochlear evoked potentials in response to pairs of pulses: Effects of pulse amplitude and interpulse interval	Finley, Wilson, van den Honert and Lawson
QPR 7	High rate studies, subject SR2	Wilson, Finley, Zerbi, Lawson and van den Honert
QPR 8	Relationships between temporal patterns of nerve activity and pitch judgments for cochlear implant patients	Wilson, Zerbi, Finley, Lawson and van den Honert
QPR 9	Development of the evoked potentials laboratory	van den Honert, Finley and Wilson
QPR 10	Effects of upward extension of the frequency range analyzed by CIS processors	Zerbi, Lawson and Wilson
QPR 11	Design of new speech test materials and comparisons with standard materials	Lawson, Wilson and Zerbi
Final Report	Summary of major activities and achievements for the project; New directions in implant design; Summary of reporting activity for the project	Wilson, Lawson, Zerbi, Finley and van den Honert

NIH project N01-DC-8-2105

September 30, 1998 through March 31, 2002

Report	Topic(s)	Authors
QPR 1	Pitch discrimination among electrodes for each of three subjects with bilateral cochlear implants; Measurement of interaural timing and amplitude difference cues for those same subjects	Lawson, Zerbi and Wilson
QPR 2	Measures of performance over time following substitution of CIS for CA speech processors	Lawson, Wilson and Zerbi
QPR 3	Effects of manipulations in mapping functions on the performance of CIS processors	Wilson, Lawson, Zerbi and Wolford

QPR 4	Speech reception with bilateral cochlear implants; Update on longitudinal studies	Lawson, Wilson, Zerbi and Finley
QPR 5	Comprehensive review of strategies for representing speech information with cochlear implants	Wilson, Lawson, Wolford and Brill
QPR 6	Effects of changes in stimulus rate and envelope cutoff frequency for CIS processors	Wilson, Wolford and Lawson
QPR 7	Further studies to evaluate effects of changes in stimulus rate and envelope cutoff frequency for CIS processors	Wilson, Wolford and Lawson
QPR 8	Combined electric and acoustic stimulation of the same cochlea	Lawson, Wilson, Wolford, Brill and Schatzer
QPR 9	Binaural cochlear implant findings: Summary of initial results with eleven subjects	Lawson, Brill, Wolford, Wilson and Schatzer
QPR 10	New tools, including (a) evaluation of the TIMIT Speech Database for use in studies with implant subjects, (b) processing of speech and other sounds using head-related transfer functions, and (c) an Access database of speech processor designs and study results	Cox, Wolford, Schatzer, Wilson and Lawson
QPR 11	Further studies to evaluate combined electric and acoustic stimulation	Brill, Lawson, Wolford, Wilson and Schatzer
QPR 12	Further studies regarding benefits of bilateral cochlear implants	Lawson, Wolford, Brill, Schatzer and Wilson
QPR 13	Cooperative electric and acoustic stimulation of the peripheral auditory system – Comparison of ipsilateral and contralateral implementations	Lawson, Wolford, Brill, Wilson and Schatzer
Final Report	Summary of major activities and achievements for the project; Some likely next steps in the further development of cochlear prostheses; Summary of reporting activity for the project	Wilson, Brill, Cartee, Cox, Lawson, Schatzer and Wolford

NIH project N01-DC-2-1002

April 1, 2002 through March 31, 2006

Report	Topic(s)	Authors
QPR 1	Pitch-matched and pitch-distinct electrode pairs in bilaterally implanted arrays	Lawson, Wolford, Wilson and Schatzer
QPR 2	Longitudinal studies of improvement in performance with early experience using binaural cochlear implants	Lawson, Wolford, Wilson and Schatzer
QPR 3	Additional perspectives on speech reception with combined electric and acoustic stimulation	Wilson, Wolford, Lawson and Schatzer
QPR 4	Measurements of interaural timing differences; update on longitudinal studies of early performance improvements with binaural cochlear implants	Wolford, Lawson, Schatzer, Sun and Wilson
QPR 5	Recent enhancements of the speech laboratory system	Schatzer, Zerbi, Sun, Cox, Wolford, Lawson and Wilson
QPR 6	Signal processing strategy for a closer mimicking of normal auditory functions	Schatzer, Wilson, Wolford and Lawson

QPR 7	Combined use of dual-resonance nonlinear (DRNL) filters and virtual channels	Wilson, Wolford, Schatzer, Sun and Lawson
QPR 8	Representation of fine structure or fine frequency information with cochlear implants	Wilson, Sun, Schatzer and Wolford
QPR 9	Intracochlear potentials evoked by electrical stimulation with phase-separated balanced biphasic pulses	Cartee, Wilson, Cox, Wolford and Lawson
QPR 10	Pitch ranking of electrodes for 22 subjects with bilateral implants; melody recognition tests for cochlear implant research	Lawson, Wilson, Wolford, Sun and Schatzer
QPR 11	Laboratory interface for the new Med-El PULSARCI ¹⁰⁰ implant; further development of the streaming mode tools	Schatzer, Zerbi, Wilson, Cox, Lawson and Sun
QPR 12	Initial studies with a recipient of the PULSAR implant	Lawson, Wilson, Schatzer and Sun
QPR 13	Progress in Nucleus percutaneous studies	Lawson, Wilson and Sun
QPR 14	Further progress in the Nucleus percutaneous studies	Lawson, Sun and Wilson
QPR 15	Results from the Nucleus percutaneous studies	Lawson, Sun and Wilson
Final Report	Major areas of research under this contract and suggested future directions	Wilson and Lawson

Submitted Manuscripts Now in Review

None at present

Invited Articles in Preparation

1. Wilson BS, O'Donoghue G, Tucci DL, Merson M: Global hearing health care. Commissioned feature article for The Lancet.

Other Articles in Advanced Stages of Preparation

1. Wilson BS, Wolford RD, Lorens A, Lawson DT, Adunka O, Brill S, Pfennigdorff T, Kiefer J, Pok M, Pillsbury CH, Baumgartner W-D, Gstöttner W: Combined electric and acoustic stimulation of the auditory system for persons with residual, low-frequency hearing. To be submitted for publication in Ear & Hearing.
2. Lorens A, Wilson BS, Piotrowska A, Skarzynski H: The surprising benefits of cochlear implantation for persons with high levels of residual hearing. To be submitted for publication in Otology & Neurotology or Ear & Hearing.
3. Piotrowska A, Wilson BS, Lorens A, Skarzynski H: Alternative approaches for handling un-measurable thresholds in comparisons of audiograms between groups or treatment conditions. To be submitted as a "Methodological paper" for publication in Hearing Research or as a Letter for publication in the J. Acoust. Soc. Am.

Patents

A policy was developed at the Research Triangle Institute (RTI) in the mid 1980s to donate all results from its NIH-sponsored research on cochlear implants (CIs) to the public domain. Thus, patent protection was not sought for the great majority of Wilson's inventions. More information about the

policy and its highly positive impact on humanity is presented in Chapter 1 of the recent book by Wilson and Dorman, *Better Hearing with Cochlear Implants: Studies at the Research Triangle Institute* (Plural, 2012).

The policy was approved by the RTI President in 1985 and remained in effect until Wilson retired from RTI in 2007. Patent protection has been sought for some of Wilson's inventions that were conceived following the expiration of the policy. In addition, patent protection was sought for an invention by Jay T. Rubinstein and Wilson while the policy was in force, as: (1) Jay was not a member of the RTI staff and therefore not covered by the policy and (2) the invention arose outside of the NIH-sponsored research.

At present, two patents have been issued to Wilson and two applications for other patents are currently under review. In addition, eleven provisional patent applications are in the final stages of preparation.

The issued patents are:

Speech processing system and method using pseudospontaneous stimulation

Inventors: Jay T. Rubinstein and Blake S. Wilson

US Patent 6,907,130; June 14, 2005

Low pulse rate cochlear implant stimulation in conjunction with a separate representation of fundamental frequencies and voiced/unvoiced distinctions

Inventor: Blake S. Wilson

Australian Patent AU2010292140; July 11, 2013

The submitted applications are:

Low pulse rate cochlear implant stimulation in conjunction with a separate representation of fundamental frequencies and voiced/unvoiced distinctions

Inventor: Blake S. Wilson

US Patent Application 12/879,159; September 10, 2010

International Patent Application PCT/US10/48350; September 10, 2010

International Publication Number WO2011/031918 A1

Using alternative stimulus waveforms to improve pitch percepts elicited with cochlear implant systems

Inventors: Joshua S. Stohl and Blake S. Wilson

US Patent Application 13/786,764; March 6, 2013

Lectures as a Guest of Honor

1. Wilson BS: High rate coding strategies. *International Workshop on Cochlear Implants*, Vienna, Austria, October 24-25, 1996.
2. Wilson BS: Speech coding strategies. *5th Int. Cochlear Implant Workshop and 1st Auditory Brainstem (ABI) Workshop*, Würzburg, Germany, June 30 through July 4, 1999.
3. Wilson BS, Lawson DT: Experiments in bilateral implanted patients using the CIS strategy. *5th Int. Cochlear Implant Workshop and 1st Auditory Brainstem (ABI) Workshop*, Würzburg, Germany, June 30 through July 4, 1999.
4. Wilson BS: The future of cochlear implants. *5th Int. Cochlear Implant Workshop and 1st Auditory Brainstem (ABI) Workshop*, Würzburg, Germany, June 30 through July 4, 1999.
5. Wilson BS, Brill SM, Lawson DT, Schatzer R, Wolford RD, Zerbi M, Müller J, Schön F, Tyler R: Psychophysical and speech reception results from studies with recipients of bilateral cochlear implants. *Wullstein Symposium*, Würzburg, Germany, April 26-30, 2001. (The *Wullstein Symposium* included the *2nd Conference on Bilateral Cochlear Implantation and Signal Processing*, the *6th International Cochlear Implant Workshop*, and the *2nd Auditory Brainstem Implant (ABI) Workshop*.)

6. Wilson BS: The RTI's perspective on bilateral cochlear implantation. *Wullstein Symposium 2002*, Würzburg, Germany, December 12-17, 2002. (This second *Wullstein Symposium* included the 3rd *Conference on Bilateral Cochlear Implantation and Bilateral Signal Processing*, the 7th *International Cochlear Implant Workshop*, and the 1st *Workshop on Binaural Rehabilitation*.)
7. Wilson BS: Evaluation of combined EAS in studies at the Research Triangle Institute. *Hearing Preservation Workshop II*, Frankfurt, Germany, October 17-18, 2003.
8. Wilson BS: Speech coding for bilateral cochlear implants. *Fifth Wullstein Symposium on Bilateral Cochlear Implants and Binaural Signal Processing*, Würzburg, Germany, December 2-5, 2004.
9. Wilson BS, et al.: EAS and possible mechanisms underlying benefits. *Hearing Preservation Workshop IV*, Warsaw-Kajetany, Poland, October 14-15, 2005.
10. Wilson BS: Cochlear implants: A remarkable past and a brilliant future. *Ninth International Cochlear Implant Conference*, Vienna, Austria, June 14-17, 2006.
11. Wilson BS: Cochlear implants: A remarkable past and a brilliant future. *Workshop on the Present Status and Future Directions of Cochlear Implants*, Nano Bioelectronics & Systems Research Center, Seoul National University, Seoul, Korea, August 25, 2006.
12. Wilson BS: My vision for a cochlear implant in five years. *Sixth Wullstein Symposium 2006: New Developments in Hearing Technology*, Würzburg, Germany, December 7-10, 2006.
13. Wilson BS: Acceptance of the Distinguished Alumnus Award. *Annual Awards Banquet and Ceremony*, Pratt School of Engineering, Durham, NC, USA, April 21, 2007.
14. Wilson BS: Cochlear implants: Present results and future possibilities. *Friedberger Cochlear Implant Symposium*, Bad Nauheim, Germany, June 28-30, 2007.
15. Wilson BS: Partial deafness cochlear implantation (PDCI) and electro-acoustic stimulation (EAS). *9th European Symposium on Paediatric Cochlear Implantation*, Warsaw, Poland, May 14-17, 2009. (This lecture also is listed as one of the four keynote speeches in the Program for the Symposium.)
16. Wilson BS: Two opportunities for the further development and broader application of cochlear implants. *Munich Hearing Implant Symposium: Reaching New Heights*, Ludwig Maximilians Universität, Munich, Germany, December 8-10, 2011. (This lecture also is listed as one of the four keynote speeches in the Program for the Symposium.)

Nalli Family Distinguished Lecture

1. Wilson BS: Where are we and where are we headed with cochlear implants? Nalli Family Lecture, The Hospital for Sick Children, University of Toronto, Toronto, Canada, February 17, 2005.

Neel Distinguished Research Lectureship

1. Wilson BS, Miyamoto RT: How basic science has influenced the design of cochlear implants? *112th Annual Meeting of the American Academy of Otolaryngology, Head and Neck Surgery*, Chicago, IL, USA, September 21-24, 2008. (This meeting was attended by more than 8,500 physicians and other professionals; the Neel Distinguished Research Lectureship is among the highest honors conferred by the *American Academy*. The prior lecture in the series was by Elias Zerhouni, M.D., the then Director of the United States' National Institutes of Health.)

Chandra Sekhar Lecture

1. Wilson BS: Thinking about the hearing brain in designs and applications of cochlear implants. The *Chandra Sekhar Lecture*, New York University School of Medicine, NYU Langone Medical Center, New York, NY, USA, April 10, 2013. (The Chandra Sekhar lectures honor Dr. Hosakere K. Chandra Sekhar for his work in temporal bone histology and for his contributions to education and clinical care during his distinguished career at the NYU School of Medicine, which began in 1971. The lectures are supported by a fund established by his family upon his retirement in 2008; the present lecture by Wilson was the second in the series of lectures.)

Hopkins Medicine Distinguished Speaker Lecture

1. Wilson BS: Do you hear what I hear? – Cochlear implants & the past, present, and future of prosthetic hearing. Johns Hopkins University School of Medicine, Baltimore, MD, USA, February 4, 2014. (The following is a description of the Distinguished Speakers Series: “The Distinguished Speaker Series was established by a group of medical students at Johns Hopkins to inform and inspire medical scientists, clinicians, public health leaders, and students through scholarly exchange with the world’s foremost visionaries and thinkers. Our inaugural event brought together seven recipients of the MacArthur “Genius Grant” for a lively dialogue on the ways in which creative minds engage the public. Since then, we have hosted Lasker Award recipient Dr. Anthony S. Fauci, noted bioethicist Dr. Charles Bosk, and Dr. Françoise Barré-Sinoussi, recipient of the Nobel Prize in Physiology or Medicine and co-discoverer of HIV. Our most recent events featured Dr. K. Anders Ericsson, cognitive psychologist and expert on expertism, Dr. Robert Langer, head of the largest biomedical engineering laboratory in the world, and five exceptional faculty at Johns Hopkins presenting their personal and professional journeys in medicine.”)

Vanderbilt University Medical Center Flexner Discovery Lecture

1. Wilson BS: The development of the modern cochlear implant and the first substantial restoration of a human sense using a medical intervention. Vanderbilt University Medical Center, Nashville, TN, USA, March 13, 2014. (The Flexner Discovery Lecture Series features the world’s most eminent scientists, who speak on the highest-impact research and policy issues in science and medicine today. Prior speakers have included multiple Nobel Laureates and members of the United States’ Institute of Medicine.)

2014 Lasker Lecture

1. Wilson BS: Toward better representations of sound with cochlear implants. Keck School of Medicine, University of Southern California, Los Angeles, CA, USA, April 10, 2014.

Göttingen Sensory Lecture

1. Wilson BS: Brain centric approaches to designs and applications of cochlear implants. Georg-August-Universität Göttingen, Göttingen, Germany, June 24, 2014. (The Lecture was jointly supported by the collaborative sensory research grant on Cellular Mechanisms of Sensory Processing and the Bernstein Center for Computational Neuroscience.)

Graham Fraser Memorial Lecture

1. Wilson BS: The cochlear implant and the first substantial restoration of a human sense using a medical intervention. Lecture presented in conjunction with the *Annual Meeting of the British Cochlear Implant Group*, Bristol, UK, March 19-20, 2015. (The Graham Fraser Memorial Lectures celebrate his life and achievements and are the most prestigious named lectures in the fields of cochlear implants and remediation of severe losses in hearing. More information about the lectures is presented at <http://www.grahamfraserfoundation.org.uk/memlects.htm>.)

Distinguished Guest Address

1. Wilson BS: A designer’s perspective of cochlear implants. *Fourth Workshop on Transcanal Techniques for Cochlear Implants*, New Delhi, India, February 4-5, 2012.

Honored Special Guest Address

1. Wilson BS, Schatzer R, Wolford RD, Sun X: Two new directions in implant design. *Eighth International Cochlear Implant Conference*, Indianapolis, IN, USA, May 10-13, 2004.

Inaugural Plenary Addresses

1. Wilson BS: Cochlear implants: Matching the prosthesis to the brain and facilitating desired plastic changes in brain function. *2nd Congress of Spanish-America on Cochlear Implants and Related Sciences*, Cartagena, Columbia, December 1-3, 2010.
2. Wilson BS: The significance of the 2013 Lasker~DeBakey Clinical Medical Research Award to the field of cochlear implants and for fulfilling the mission of the American Cochlear Implant Alliance. *CI 2013 Conference – American Cochlear Implant Alliance*, Washington DC, USA, October 24-26, 2013.

Dean's Leadership in Innovation Seminar

1. Wilson BS: Cochlear implants: A remarkable past and a brilliant future. Faculty of Engineering and Information Technology, University of Technology, Sydney, Sydney, Australia, October 27, 2011.

Invited Address for the President's Symposium within the 2012 Meeting of the ARO

1. Wilson BS, Dorman MF, Woldorff MG, Tucci DL: A “top down” or “cognitive neuroscience” approach to cochlear implant designs and fittings. Presidential Symposium on *Listening with the Brain: Cochlear Implants and Central Auditory System Plasticity*, 35th Midwinter Meeting, Association for Research in Otolaryngology, San Diego, CA, USA, February 25-29, 2012.

Presentation to the Duke University Board of Trustees

1. Wilson BS: The 2013 Lasker~DeBakey Award and the first substantial restoration of a human sense using a medical intervention. Duke University, Durham, NC, USA, December 6, 2013.

Distinguished Speaker Address

1. Wilson BS: Progress and remaining problems in the development of the cochlear implant. *Future of Hearing Symposium*, sponsored by the Cluster of Excellence “Hearing4all,” Oldenburg, Germany, November 6-7, 2015.

Inauguration Speech for the Institute for Auditory Neuroscience at the University of Göttingen

1. Wilson BS: Auditory neuroscience: The neuroprosthetics perspective. One of three lectures to inaugurate the new Institute for Auditory Neuroscience at the University of Göttingen, Göttingen, Germany, March 21, 2015.

Grand Rounds Presentations

1. Farmer JC Jr., Kenan PD, Wilson BS: Cochlear implants. Surgical Grand Rounds, Duke University Medical Center, Durham, NC, USA, November, 1985.
2. Farmer JC Jr., Javel E, McElveen JT Jr., Wilson BS: Advances in cochlear implants. Surgical Grand Rounds, Duke University Medical Center, Durham, NC, USA, December 13, 1989.
3. Wilson BS: Advances in cochlear implant research. Grand Rounds presentation, Department of Otolaryngology, University of Toronto, Toronto, Canada, February 18, 2005.
4. Wilson BS: The development of the modern cochlear implant and the first substantial restoration of a human sense using a medical intervention. Surgical Grand Rounds, Duke University Medical Center, Durham, NC, USA, March 5, 2014.
5. Wilson BS: Thinking about the hearing brain in designs and applications of cochlear implants. Grand Rounds presentation, Department of Otolaryngology – Head & Neck Surgery and Department of Hearing and Speech Sciences, Vanderbilt University Medical Center, Nashville, TN, USA, March 14, 2014.

6. Wilson BS: The development of the modern cochlear implant and the first substantial restoration of a human sense using a medical intervention. Surgical Grand Rounds, Department of Otolaryngology – Head & Neck Surgery, Northwestern University Medical Center, Chicago, IL, USA, April 16, 2015.

Keynote Speeches

1. Wilson BS: Suggestions for the future development of cochlear implants. *Third European Symposium on Paediatric Cochlear Implantation*, Hannover, Germany, June 6-8, 1996. (This presentation was the penultimate summary lecture for the Symposium, preceding the concluding lecture by Professor Lenarz, General Chair.)
2. Wilson BS: New directions in implant design. *4th European Symposium on Paediatric Cochlear Implantation*, 's-Hertogenbosch, The Netherlands, June 14-17, 1998.
3. Wilson BS: Some likely next steps in the further development of cochlear implants. *6th European Symposium on Paediatric Cochlear Implantation*, Las Palmas, Canary Islands, February 24-27, 2002.
4. Wilson BS: Future directions for cochlear implants. *7th International Cochlear Implant Conference*, Manchester, England, September 4-6, 2002.
5. Wilson BS: Where are we and where can we go with cochlear implants? *Annual Meeting of the British Cochlear Implant Group: Pushing the Boundaries of Cochlear Implantation*, Birmingham, UK, April 18-19, 2005. (This was the single keynote speech for this conference.)
6. Wilson BS: Present results and future possibilities for bilateral cochlear implants. *Sixth International Meeting on Bilateral Cochlear Implants and Binaural Signal Processing*, Bern, Switzerland, March 29-30, 2007.
7. Wilson BS: Cochlear implants. *International Workshop on Advances in Audiology*, Salamanca, Spain, May 25-26, 2007.
8. Wilson BS: The past, present, and future of cochlear implants. *Nemours Cochlear Implant Symposium*, Wilmington, Delaware, USA, October 12-13, 2009. (This was the single keynote speech for this conference.)
9. Wilson BS: The listening brain: Roles of the “auditory brain” in outcomes and designs for cochlear implants. *Perth Auditory Implant Workshop*, University of Western Australia, Perth, Australia, October 28-30, 2010.
10. Wilson BS: Cochlear implants: A remarkable past and a brilliant future. *Conference on Hearing Implants: A Remarkable Past and a Brilliant Future*, Frankfurt am Main, Germany, December 9-11, 2010.
11. Wilson BS: Cochlear implantation: A remarkable past and a brilliant future. *10th European Symposium on Paediatric Cochlear Implantation*, Athens, Greece, May 12-15, 2011.
12. Wilson BS: Cochlear implants: Matching the prosthesis to the brain and facilitating desired plastic changes in brain function. *12th International Conference on Cochlear Implants and Other Implantable Auditory Technologies*, Baltimore, MD, USA, May 3-5, 2012.
13. Wilson BS: Present and future of cochlear implants. *VI International Meeting on Advances in Audiology*, Salamanca, Spain, June 7-9, 2012.
14. Wilson BS: The four large steps forward that led to the present-day cochlear implants. *Perth Auditory Implant Workshop*, Perth, Australia, November 8-10, 2012.
15. Wilson BS: Future possibilities for combined electric and acoustic stimulation. *3rd Munich Hearing Implant Symposium: Comprehensive Hearing Implant Solutions*, Ludwig Maximilians Universität, Munich, Germany, December 12-15, 2013.
16. Wilson BS: Toward better representations of sound with cochlear implants. Special session honoring the development of the modern cochlear implant and the winners of the 2013 Lasker-DeBakey Clinical Medical Research Award, *13th International Conference on Cochlear Implants and Other Implantable Auditory Prostheses*, Munich, Germany, June 18-21, 2014.
17. Wilson BS: Evolution of electrical stimulation in the cochlea; single to multichannel to deep insertion to EAS – A historical perspective. *Conference on the APEX of the Cochlea – From Neuroanatomy to Electrical Stimulation*, Chapel Hill, NC, USA, September 4-7, 2014.

18. Wilson BS: The development of the modern cochlear implant. *10th Asia Pacific Symposium on Cochlear Implants and Related Sciences*, Beijing, China, April 30 through May 3, 2015.

Banquet Address

1. Wilson BS: How my education in engineering at Duke helped me to contribute to the development of the modern cochlear implant and the first substantial restoration of a human sense using a medical intervention. *Annual Workshop for the Graduate Program in Electrical and Computer Engineering*, Pratt School of Engineering, Duke University, Durham, NC, USA, January 23, 2014.

Additional Invited Presentations

1. Wilson BS: Speech processors for auditory prostheses. *14th Annual Neural Prosthesis Workshop*, National Institutes of Health, Bethesda, MD, USA, October, 1983.
2. Wilson BS: Speech processors for auditory prostheses. *15th Annual Neural Prosthesis Workshop*, National Institutes of Health, Bethesda, MD, USA, October, 1984.
3. Wilson BS: Coding strategies for multichannel auditory prostheses. *Gordon Research Conference on Implantable Auditory Prostheses*, Tilton, NH, USA, August 19-23, 1985.
4. Finley CC, Wilson BS: An integrated field-neuron model of intracochlear stimulation. *Gordon Research Conference on Implantable Auditory Prostheses*, Tilton, NH, USA, August 19-23, 1985.
5. Finley CC, Wilson BS: A simple finite-difference model of the field patterns produced by bipolar electrodes of the UCSF array. *IEEE Bioengineering Conference*, September 27-30, 1985.
6. Wilson BS, Finley CC: Speech processors for auditory prostheses. *IEEE Bioengineering Conference* (special session on "Signal Processing for the Hearing Impaired"), September 27-30, 1985.
7. Finley CC, Wilson BS: Models of neural stimulation for electrically-evoked hearing. *Annual Conference on Engineering in Medicine and Biology*, September 30 through October 2, 1985.
8. Wilson BS: Speech processors for auditory prostheses. *16th Annual Neural Prosthesis Workshop*, National Institutes of Health, Bethesda, MD, USA, October, 1985.
9. Wilson BS: Comparison of strategies for coding speech with multichannel auditory prostheses. *Conference on Speech Recognition with Cochlear Implants*, New York University, New York, NY, USA, April 17-19, 1986.
10. Wilson BS: Coding strategies for cochlear implants. Kresge Hearing Research Institute, University of Michigan, Ann Arbor, MI, USA, May 22, 1986.
11. Wilson BS: Ensemble models of neural discharge patterns evoked by intracochlear electrical stimulation. *International Union of Physiological Scientists (IUPS) Satellite Symposium on Advances in Auditory Neuroscience*, San Francisco, CA, USA, July 8-11, 1986.
12. Wilson BS: Processing strategies for cochlear implants. *Annual Meeting of the American College of Otolaryngologists*, San Antonio, TX, USA, September 18-19, 1986.
13. Kenan PD, Farmer JC Jr., Weber BA, Wilson BS: Cochlear implants. *Annual Meeting of the Mecklenburg County Otolaryngology, Head and Neck Surgery Society*, Charlotte, NC, fall, 1986.
14. Wilson BS: Speech processors for auditory prostheses. *17th Annual Neural Prosthesis Workshop*, National Institutes of Health, Bethesda, MD, USA, October, 1986.
15. Wilson BS: Cochlear implants. *First North Carolina Workshop on Bioelectronics* (session on "Auditory Signal Processing"), Quail Roost, NC, USA, October 24-26, 1986.
16. Wilson BS: The RTI/Duke cochlear implant program. Executive committee of the Research Triangle Institute (RTI) Board of Governors, June 17, 1987.
17. Farmer JC Jr., Wilson BS: Cochlear implantation for the profoundly deaf. Department of Physiology, Duke University Medical Center, June 18, 1987.
18. Wilson BS: Factors in coding speech for auditory prostheses. *Gordon Research Conference on Implantable Auditory Prostheses*. New London, NH, USA, June 29 through July 3, 1987.

19. Schindler RA, Wilson BS: Present status and future enhancements of the UCSF/RTI/Duke cochlear implant. *International Cochlear Implant Symposium 1987*, Düren, Germany, September 7-11, 1987.
20. Wilson BS: Speech processors for auditory prostheses. *18th Annual Neural Prosthesis Workshop*, National Institutes of Health, Bethesda, MD, USA, October, 1987.
21. Wilson BS: Review of RTI research on coding strategies for cochlear prostheses. 3M Company, St. Paul, MN, USA, November 12, 1987.
22. Wilson BS, Finley CC, White MW, Lawson DT: Comparisons of processing strategies for multichannel auditory prostheses. *Ninth Annual Conference on Engineering in Medicine and Biology* (special session on cochlear implants), Boston, MA, USA, November 13-16, 1987.
23. White MW, Finley CC, Wilson BS: Electrical stimulation model of the auditory nerve: Stochastic response characteristics. *Ninth Annual Conference on Engineering in Medicine and Biology* (special session on cochlear implants), Boston, MA, USA, November 13-16, 1987.
24. Finley CC, Wilson BS, White MW: A finite-element model of bipolar field patterns in the electrically stimulated cochlea – A two dimensional approximation. *Ninth Annual Conference on Engineering in Medicine and Biology* (special session on cochlear implants), Boston, MA, USA, November 13-16, 1987.
25. Finley CC, Wilson BS, White MW: Models of afferent neurons in the electrically stimulated ear. *Ninth Annual Conference on Engineering in Medicine and Biology* (special session on cochlear implants), Boston, MA, USA, November 13-16, 1987.
26. Wilson BS: Various coding schemes used. *Cochlear Implant Consensus Development Conference*, National Institutes of Health, Bethesda, MD, USA, May 2-4, 1988.
27. Wilson BS: Comparison of encoding schemes. *25th Anniversary Symposium of the Kresge Hearing Research Institute*, Ann Arbor, MI, USA, October 3-5, 1988.
28. Wilson BS: Speech processors for auditory prostheses. *19th Annual Neural Prosthesis Workshop*, National Institutes of Health, Bethesda, MD, USA, October, 1988.
29. Soli SD, Wilson BS: Within-subject comparisons of analog and pulsatile speech processors for cochlear implants. *Annual Meeting of the Acoustical Society of America* (special session on "Speech Processing Aids for the Handicapped"), Honolulu, Hawaii, USA, November 14-18, 1988. (Abstract published in *J Acoust Soc Am* 84: S41, 1988)
30. Wilson BS: Within-patient evaluation of speech processors. *Engineering Foundation Conference on Implantable Auditory Prostheses*, Potosi, MO, USA, July 30 through August 4, 1989.
31. Wilson BS: Comparison of analog and pulsatile coding strategies for multichannel cochlear prostheses. University of Iowa, Iowa City, IA, USA, August 28, 1989.
32. Wilson BS: Speech processors for auditory prostheses. *20th Annual Neural Prosthesis Workshop*, National Institutes of Health, Bethesda, MD, USA, October, 1989.
33. Wilson BS: Processing strategies for cochlear implants. *Third Symposium on Cochlear Implants in Children*, Indianapolis, IN, USA, January 26 and 27, 1990.
34. Wilson BS: Recent advances in the design of cochlear prostheses. Richards Medical, Memphis, TN, USA, February 5, 1990.
35. Wilson BS: Design of cochlear prostheses. *AAAS Meeting* (special session on "Cochlear Implants in Children"), New Orleans, LA, USA, February 15-20, 1990.
36. Shannon RV (moderator), Wilson BS, Eddington DK, Walliker J, Pfungst BE, Patrick JF, Rosen S (panelists): Round table discussion on "Future directions in Speech Processing." *Second International Cochlear Implant Symposium*, Iowa City, IA, USA, June 4-8, 1990.
37. Wilson BS: Speech processors for auditory prostheses. *21st Annual Neural Prosthesis Workshop*, National Institutes of Health, Bethesda, MD, USA, October, 1990.
38. Wilson BS: Strategies for representing speech with cochlear implants. *Meeting of the Acoustical Society of America* (special session on "Speech Perception and Hearing Handicap"), Baltimore, MD, USA, April 29 to May 3, 1991. (Abstract published in *J Acoust Soc Am* 89, Suppl. 1, p. 1957, 1991)
39. Wilson BS: New levels of speech recognition with cochlear implants. *1991 Conference on Implantable Auditory Prostheses*, Pacific Grove, CA, USA, June 2-7, 1991.

40. Wilson BS, Lawson DT, Finley CC: A new processing strategy for multichannel cochlear prostheses. *International Symposium on Natural and Artificial Nervous Control of Hearing and Balance*, Rheinfelden, Switzerland, September 4-8, 1991. (Lecture presented by Lawson)
41. Wilson BS: A new coding strategy for cochlear implants. *Annual Meeting of the American Neurotology Society*, Kansas City, MO, USA, September 21, 1991.
42. Wilson BS: Speech processors for auditory prostheses. *22nd Annual Neural Prosthesis Workshop*, National Institutes of Health, Bethesda, MD, USA, October, 1991.
43. Wilson BS: Processing strategies for multichannel cochlear implants. *Fourth Symposium on Cochlear Implants in Children*, Kansas City, MO, USA, February 14 and 15, 1992.
44. Wilson BS: Speech processing for auditory prostheses. Lecture for the course on "Current Status of Multichannel Cochlear Implants," *96th Meeting of the American Academy of Otolaryngology - Head & Neck Surgery*, Washington DC, USA, September 13, 1992.
45. Wilson BS: Processing strategies for multichannel cochlear implants. *First European Symposium on Paediatric Cochlear Implantation*, Nottingham, England, September 24-27, 1992.
46. Wilson BS: Panelist, round table on Programming. *First European Symposium on Paediatric Cochlear Implantation*, Nottingham, England, September 24-27, 1992.
47. Wilson BS: Speech processors for auditory prostheses. *23rd Annual Neural Prosthesis Workshop*, National Institutes of Health, Bethesda, MD, USA, October 13-15, 1992.
48. Wilson BS: Representations of envelope information with CIS and VCIS processors. *Mini Symposium on Envelope Representations with Cochlear Implants*, House Ear Institute, Los Angeles, CA, USA, February 25-28, 1993.
49. Wilson BS: Optimizing performance with new processing strategies. *1993 Cherry Blossom Conference: Current and New Applications in Hearing and Equilibrium*, American Academy of Otolaryngology -- Head & Neck Surgery, Washington DC, USA, April 2, 1993.
50. Wilson BS: Recent developments with the CIS strategies. *Third International Cochlear Implant Conference*, Innsbruck, Austria, April 4-7, 1993.
51. Wilson BS, Lawson DT, Zerbi M, Finley CC: CIS and "virtual channel" CIS (VCIS) processors. *1993 Conference on Implantable Auditory Prostheses*, Smithfield, RI, USA, July 11-15, 1993.
52. Wilson BS, Lawson DT, Zerbi M, Finley CC, Wolford RD: New processing strategies in cochlear implantation. *Annual Meeting of the American Neurotology Society* (special session on "Basic Science Update"), Minneapolis, MN, USA, October 1, 1993.
53. Wilson BS: Speech processors for auditory prostheses. *24th Annual Neural Prosthesis Workshop*, National Institutes of Health, Bethesda, MD, USA, October 13-15, 1993.
54. Wilson BS: Introduction to speech processor design and testing. *1993 Zhengzhou International Symposium on Electrical Cochlear Hearing and Linguistics*, Zhengzhou, China, October 23-26, 1993.
55. Wilson BS: New processing strategies for cochlear prostheses. *1993 Zhengzhou International Symposium on Electrical Cochlear Hearing and Linguistics*, Zhengzhou, China, October 23-26, 1993.
56. Wilson BS: Further studies with CIS and related processors. *1993 Zhengzhou International Symposium on Electrical Cochlear Hearing and Linguistics*, Zhengzhou, China, October 23-26, 1993.
57. Wilson BS: Review of speech processor studies. University of Iowa, Department of Otolaryngology – Head & Neck Surgery, Iowa City, IA, USA, January 18, 1994.
58. Wilson BS: Progress in speech processor design. *Fifth Symposium on Cochlear Implants in Children*, New York, NY, USA, February 4, 1994.
59. Wilson BS: Review of speech processor studies. Indiana University School of Medicine, Department of Otolaryngology -- Head & Neck Surgery, Indianapolis, IN, USA, March 9, 1994.
60. Wilson BS: Progress in the development of speech processors for cochlear prostheses. *127th Meeting of the Acoustical Society of America* (special session on "Electro-Auditory Prostheses"), Cambridge, MA, USA, June 8, 1994. (Abstract published in *J Acoust Soc Am* 95: 2905, 1994.)
61. Wilson BS: Cochlear modeling studies. *25th Annual Neural Prosthesis Workshop*, National Institutes of Health, Bethesda, MD, USA, October 18-21, 1994.
62. Wilson BS: Speech processors for auditory prostheses. *25th Annual Neural Prosthesis Workshop*, National Institutes of Health, Bethesda, MD, USA, October 18-21, 1994.

63. Wilson BS, Lawson DT, Zerbi M, Finley CC: New developments in speech processors. Lecture for the "Workshop on Auditory Prosthetics," *18th Midwinter Meeting of the Association for Research in Otolaryngology*, St. Petersburg, FL, USA, February 5-9, 1995. (Abstract published in ARO Abstracts, p. 97, 1995.)
64. Wilson BS: Future directions in speech processing. *CIS Workshop* (sponsored by Med El GmbH and held in conjunction with the *IIIrd International Congress on Cochlear Implant*), Paris, France, April 26, 1995.
65. Wilson BS: Continuous Interleaved Sampling and related strategies. *NIH Consensus Development Conference on Cochlear Implants in Adults and Children*, May 15-17, 1995.
66. Wilson BS: Temporal representations with cochlear implants. *1995 Conference on Implantable Auditory Prostheses*, Pacific Grove, CA, USA, August 20-24, 1995.
67. Wilson BS: Speech processors for auditory prostheses. *26th Annual Neural Prosthesis Workshop*, National Institutes of Health, Bethesda, MD, USA, October 18-20, 1995.
68. Wilson BS: Strategies for representing speech information with cochlear implants. *6th Symposium on Cochlear Implants in Children*, Miami Beach, FL, USA, February 2-3, 1996.
69. Wilson BS, Finley CC, Lawson DT, Zerbi M: Temporal representations with cochlear implants. *Third European Symposium on Paediatric Cochlear Implantation*, Hannover, Germany, June 6-8, 1996.
70. Wilson BS: Progress in the development of speech processing strategies for cochlear implants. University of Iowa, Department of Otolaryngology – Head and Neck Surgery, Iowa City, IA, USA, July 29, 1996.
71. Wilson BS, Lawson DT: Speech processors for auditory prostheses. *27th Annual Neural Prosthesis Workshop*, National Institutes of Health, Bethesda, MD, USA, October 16-18, 1996.
72. Wilson BS: Possibilities for the further development of speech processor designs. *Fifth International Cochlear Implant Conference*, New York, NY, USA, May 1-3, 1997.
73. Lawson DT, Wilson BS, Zerbi M, Roush PA, van den Honert C, Finley CC, Tucci DL, Farmer JC Jr.: Within patient comparisons among processing strategies for cochlear implants. *130th Annual Meeting of the American Otological Society*, Scottsdale, AZ, USA, May 10-11, 1997. (Lecture presented by Wilson)
74. Lawson DT, Wilson BS, Zerbi M, van den Honert C, Finley CC, Farmer JC Jr., McElveen JT, Roush PA: Bilateral cochlear implants controlled by a single speech processor. *130th Annual Meeting of the American Otological Society*, Scottsdale, AZ, USA, May 10-11, 1997.
75. Wilson BS: Design of speech processors for cochlear prostheses. Johns Hopkins University, Department of Biomedical Engineering, May 30, 1997.
76. Wilson BS, Finley CC, Zerbi M, Lawson DT, van den Honert C: Representations of temporal information in responses of the human auditory nerve to electrical stimuli. *1997 Conference on Implantable Auditory Prostheses*, Pacific Grove, CA, USA, August 17-21, 1997.
77. Finley CC, Wilson BS, van den Honert C: Fields and EP responses to electrical stimulation: Spatial distributions, electrode interactions and regional differences along the tonotopic axis. *1997 Conference on Implantable Auditory Prostheses*, Pacific Grove, CA, USA, August 17-21, 1997.
78. Lawson DT, Wilson BS, Zerbi M, Finley CC: Design differences and parametric adjustments among CIS and related processors. *1997 Conference on Implantable Auditory Prostheses*, Pacific Grove, CA, USA, August 17-21, 1997.
79. Wilson BS: Speech processors for auditory prostheses. *28th Annual Neural Prosthesis Workshop*, National Institutes of Health, Bethesda, MD, USA, October 15-17, 1997.
80. Wilson BS: Review of studies at RTI with recipients of bilateral cochlear implants. University of Iowa, Department of Otolaryngology, Head & Neck Surgery, Iowa City, IA, USA, January 27, 1998.
81. Wilson BS, Pierschalla M: Development of cochlear prostheses. *NIH Bioengineering Symposium on "Building the Future of Biology and Medicine,"* National Institutes of Health, Bethesda, MD, USA, February 27 and 28, 1998. (This was one of five invited poster presentations to represent bioengineering research supported by the NIDCD.)
82. Wilson BS: Possibilities for improving the performance of cochlear prostheses. University of Innsbruck, Innsbruck, Austria, June 18, 1998.

83. Wilson BS: Speech processors for auditory prostheses. *29th Annual Neural Prosthesis Workshop*, National Institutes of Health, Bethesda, MD, USA, October 28-20, 1998.
84. Finley CC, van den Honert C, Wilson BS, Miller RL, Cartee LA, Smith DW, Niparko JK: Factors contributing to the size, shape, latency, and distribution of intracochlear evoked potentials. *1999 Conference on Implantable Auditory Prostheses*, Pacific Grove, CA, USA, August 29 through September 3, 1999.
85. Wilson BS, Zerbi M, Finley CC, Lawson DT, van den Honert C: Relationships among electrophysiological, psychophysical and speech reception measures for implant patients. *1999 Conference on Implantable Auditory Prostheses*, Pacific Grove, CA, USA, August 29 through September 3, 1999.
86. Lawson DT, Wilson BS, Zerbi M, Finley CC: Future directions in speech processing for cochlear implants. *1999 Conference on Implantable Auditory Prostheses*, Pacific Grove, CA, USA, August 29 through September 3, 1999. (Wilson presented the talk for Lawson, who could not attend the conference due to illness.)
87. Wilson BS: Speech processors for auditory prostheses. *30th Annual Neural Prosthesis Workshop*, National Institutes of Health, Bethesda, MD, USA, October 12-14, 1999.
88. Wilson BS: Psychophysical measures and speech understanding in bilaterally implanted patients. *Bilateral Research Meeting*, Frankfurt, Germany, December 3, 1999. (This meeting was sponsored by Med El GmbH.)
89. Wilson BS: New directions in cochlear implants. *6th International Cochlear Implant Conference*, Miami Beach, FL, USA, February 3-5, 2000.
90. Wilson BS, Lawson DT, Brill SM, Wolford RD, Schatzer R: Binaural cochlear implants. *Conference on Binaural Hearing, Hearing Loss, Hearing Aids, & Cochlear Implants*, Iowa City, IA, USA, June 22-24, 2000.
91. Tyler R, Parkinson A, Gantz B, Rubinstein J, Wilson B, Witt S, Wolaver A, Lowder M: Independent binaural cochlear implants. *Conference on Binaural Hearing, Hearing Loss, Hearing Aids, & Cochlear Implants*, Iowa City, IA, USA, June 22-24, 2000.
92. Wilson BS, Lawson DT, Brill SM, Wolford RD, Schatzer R: Speech processors for auditory prostheses. *31st Annual Neural Prosthesis Workshop*, National Institutes of Health, Bethesda, MD, USA, October 25-7, 2000.
93. Lawson DT, Wilson BS, Wolford RD, Brill SM, Schatzer R: Initial work to restore binaural hearing with bilateral cochlear implants. *4th International Surgical Workshop on Aesthetic Rhinoplasty, Middle Ear Surgery, and State of Art Symposium*, Mumbai, India, November 14, 2000.
94. Lawson DT, Wilson BS, Wolford RD, Brill SM, Schatzer R: Next steps in the further development of cochlear implants. *4th International Surgical Workshop on Aesthetic Rhinoplasty, Middle Ear Surgery, and State of Art Symposium*, Mumbai, India, November 15, 2000.
95. Lawson DT, Wilson BS, Wolford RD, Brill SM, Schatzer R: Next steps in the continuing development of cochlear prostheses: Bilateral implants and combined electrical and acoustic stimulation. *International Ear Surgery Workshop and The Millennium State of Art Symposium*, Indore, India, November 17, 2000.
96. Wilson BS, Lawson DT, Wolford R, Brill SM, Schatzer R, Müller J, Schön F, Tyler RS, Zerbi M: Bilateral cochlear implants. *First Investigators' Meeting on Bilateral Cochlear Implantation*, Stans, Austria, November 29, 2000.
97. Helms J (moderator), Baumgatner W-D, Fitzgerald D, Heusler R, Hildmann H, Hockman M, van Hoesel R, Müller J, Vischer M, Wilson B: Round table discussion on bilateral cochlear implantation. *Wullstein Symposium*, Würzburg, Germany, April 26-30, 2001. (The *Wullstein Symposium* included the *2nd Conference on Bilateral Cochlear Implantation and Signal Processing*, the *6th International Cochlear Implant Workshop*, and the *2nd Auditory Brainstem Implant (ABI) Workshop*.)
98. Lawson DT, Brill SM, Wolford RD, Wilson BS, Schatzer R: Speech processors for binaural stimulation. *2001 Conference on Implantable Auditory Prostheses*, Pacific Grove, CA, USA, August 19-24, 2001.

99. Wilson BS, Brill SM, Cartee LA, Lawson DT, Schatzer R, Wolford RD: Some likely next steps in the further development of cochlear prostheses. *2001 Conference on Implantable Auditory Prostheses*, Pacific Grove, CA, USA, August 19-24, 2001.
100. Wilson BS, Lawson DT, *et al.*: Speech processors for auditory prostheses. *32nd Annual Neural Prosthesis Workshop*, National Institutes of Health, Bethesda, MD, USA, October 17-19, 2001.
101. Wilson BS, Lawson DT, Brill SM, Wolford RD, Schatzer R (RTI); Kiefer J, Pfennigdorff T, Tillein J, Gstöttner W (J. W. Goethe Universität, Frankfurt): Pillsbury H, Gilmer C (UNC Chapel Hill): Combined electric and acoustic stimulation (EAS) studies at the Research Triangle Institute. *2nd Focus Meeting on Electric-Acoustic Stimulation (EAS)*, Las Palmas, Canary Islands, February 24, 2002. (This workshop was sponsored by Med El GmbH.)
102. Cooper H, Tyler RS (moderators), Graham J, Wilson BS, Plant G, Saeed S (panelists): Panel on the future for adults. *7th International Cochlear Implant Conference*, Manchester, England, September 4-6, 2002.
103. Wilson BS: Speech processors for auditory prostheses. *33rd Annual Neural Prosthesis Workshop*, National Institutes of Health, Bethesda, MD, USA, October 16-18, 2002.
104. Wilson BS: Evaluation of combined EAS in studies at the Research Triangle Institute. *Hearing Preservation Workshop*, Indiana University School of Medicine, Indianapolis, IN, USA, November 8-10, 2002.
105. Brill SM, Wilson BS: Speech coding strategies for binaural cochlear implants. *6th Annual Conference of the German Audiological Society (DGA)*, Würzburg, Germany, March 26-29, 2003.
106. Wilson BS: Recent progress and likely next steps in the development of cochlear implants. *VII International Conference on Cochlear Implants and Related Audiological Sciences*, Warsaw – Kajetany, Poland, May 22-25, 2003.
107. Wilson BS: Results from speech reception studies. Satellite Symposium on “Partial deafness cochlear implantation,” *VII International Conference on Cochlear Implants and Related Audiological Sciences*, Warsaw – Kajetany, Poland, May 22-25, 2003.
108. Wilson BS: Recent and future cochlear implant stimulation strategies. Conference celebrating *25 Years of Cochlear Implants in Vienna*, Vienna, Austria, June 19, 2003.
109. Wilson BS, Wolford RD, Lawson DT, Schatzer R, Brill SM: Evaluation of combined EAS in studies at the Research Triangle Institute. *2003 Conference on Implantable Auditory Prostheses*, Pacific Grove, CA, USA, August 17-22, 2003.
110. Tyler R, Witt S, Dunn C, Kane D, Kenworthy M, Wilson B, Rubinstein J, Gantz B, Preece J, Parkinson A: A framework for cochlear implantation guidelines in the case of monaural and binaural fittings. *2003 Conference on Implantable Auditory Prostheses*, Pacific Grove, CA, USA, August 17-22, 2003.
111. Wilson BS, Lawson DT, Cartee LA, Wolford RD, Schatzer R, Sun X, Cox JH, Lopez-Poveda E, Zerbi M: Speech processors for auditory prostheses. *34th Annual Neural Prosthesis Workshop*, National Institutes of Health, Bethesda, MD, USA, October 21-3, 2003. (Presented by Dewey Lawson and Reinhold Schatzer)
112. Wilson BS: Future developments of CI. *II Meeting Consensus on Auditory Implants*, Valencia, Spain, February 19-21, 2004.
113. Wilson BS: Recent progress and some possible next steps with cochlear implants. Symposium in honor of Franz Schön, Ph.D., on the occasion of his retirement, Würzburg, Germany, March 20, 2004.
114. Wilson BS, Wolford RD, Lawson DT, Schatzer R, Brill S, *et al.*: Combined electric-acoustic stimulation (EAS) of the auditory system. *Med-El Satellite Meeting, Eighth International Cochlear Implant Conference*, Indianapolis, IN, USA, May 10-13, 2004. (Honorary Speaker presentation)
115. Wilson BS: Update on EAS studies at the Research Triangle Institute. *Hearing Preservation Workshop III*, Dallas, TX, USA, October 15-16, 2004.
116. Wilson BS: The auditory prosthesis as a paradigm for successful neural interfaces. *Neural Interfaces Workshop*, National Institutes of Health, Bethesda, MD, USA, November 15-17, 2004.

117. Wilson BS, Lorens A, et al.: Evaluation of combined electric and acoustic stimulation of the auditory system in studies at the Research Triangle Institute. *8th International Conference on Advances in Diagnosis and Treatment of Auditory Disorders*, Kajetany, Poland, May 19-21, 2005. (Presented by Artur Lorens)
118. Wilson BS: Moderator's overview and introduction, session on Signal Processing and Speech in Noise. *2005 Conference on Implantable Auditory Prostheses*, Pacific Grove, CA, USA, July 30 to August 4, 2005.
119. Wilson BS, Müller JM, Wolford RD, Lawson DT: Signal processing for binaural devices. *International Binaural Symposium 2005*, Manchester, UK, October 29-31, 2005.
120. Wilson BS: The auditory prosthesis as a paradigm for successful neural interfaces. *Ninth Annual Meeting of the North American Neuromodulation Society*, Washington DC, USA, November 10-12, 2005.
121. Gstöttner W (Moderator), Wilson B, Lorens A, Kiefer J, Gantz B, James C, Baumgartner W-D: Roundtable on Electric Acoustic Stimulation. *Ninth International Cochlear Implant Conference*, Vienna, Austria, June 14-17, 2006.
122. Wilson BS: Cochlear implants: A remarkable past and a brilliant future. *World Congress on Medical Physics and Biomedical Engineering 2006*, Seoul, Korea, August 27 through September 1, 2006.
123. Wilson BS: Cochlear implants: A remarkable past and a brilliant future. University lecture sponsored by the Hearing and Speech Research Laboratory and the Departments of Cognitive Neuroscience, Bioengineering, and Otolaryngology, Head and Neck Surgery, University of California at Irvine, Irvine, CA, USA, November 8, 2006.
124. Wilson BS, Dorman MF: A new "top down" or "cognitive neuroscience" approach to cochlear implant design. The National Academics and Keck Futures Initiative on *Smart Prosthetics: Exploring Assistive Devices for the Body and Mind*, Arnold & Mabel Beckman Center, Irvine, CA, USA, November 9-11, 2006. (invited poster presentation)
125. Wilson BS: The surprising performance of present-day cochlear implants. *Symposium in Honor of Prof. Dr. Jan Helm's 70th Birthday*, Würzburg, Germany, March 3, 2007.
126. Wilson BS: The surprising performance of present-day cochlear implants. *Special Guest Address*, International Centre of Hearing and Speech, Warsaw-Kajetany, Poland, April 26, 2007.
127. Wilson BS: Cochlear implants from past to present. *Symposium in Celebration of 15 Years of Cochlear Implants in Poland*, International Centre of Hearing and Speech, Warsaw-Kajetany, Poland, July 13, 2007.
128. Wilson BS: A new "top down" or "cognitive neuroscience" approach to the design of cochlear implants. Special meeting on *The Future of Cochlear Implants: Roles of the Brain in Implant Outcomes and Design*, Dallas, TX, USA, August 17, 2007.
129. Lorens A, Wilson BS, Piotrowska A, Skarzynski H: The surprising benefits of cochlear implantation for persons with high levels of residual hearing. *7th Wullstein Symposium*, Würzburg, Germany, December 4-7, 2008. (Presented by Wilson by invitation.)
130. Wilson BS: Cochlear implants: Design aspects. Invited lecture for Duke University course BME 265 on Neural Prosthetic Systems, Pratt School of Engineering, March 19, 2009.
131. Wilson BS: The past, present, and future of cochlear implants. Invited lecture for the Hearing and Chemical Senses Program, Kresge Hearing Research Institute, University of Michigan, April 29, 2009.
132. von Ilberg Ch, Lorens A (moderators), Uziel A, Podskarbi-Fayette R, Lenarz T, Baumgartner W-D, Wilson B, Kiefer J, Batman C, Bebear JP: Round Table on Treatment of Partial Deafness. *9th European Symposium on Paediatric Cochlear Implantation*, Warsaw, Poland, May 14-17, 2009.
133. Wilson BS: Partial deafness cochlear implantation (PDCI) and electro-acoustic stimulation (EAS). *Hearing Preservation Workshop VIII*, Vienna, Austria, October 15-18, 2009.
134. Wilson BS: Signal processing and binaural integration of cochlear implant and normal contralateral hearing. *8th Wullstein Symposium: Treatment of Unilateral Deafness*, Würzburg, Germany, December 11-12, 2009.

135. Müller J (moderator), Kleine Punte A, Hagan R, Brill S, Walger M, Wilson B, Aschendorff A, McKinnon B: Concluding discussion and consensus statement on treatment of unilateral deafness. *8th Wullstein Symposium: Treatment of Unilateral Deafness*, Würzburg, Germany, December 11-12, 2009.
136. Wilson BS: A “top-down” or “cognitive neuroscience” approach to cochlear implant designs. Duke Institute for Brain Sciences workshop on *Listening with the Brain: New Approaches to Optimizing the Effectiveness of Cochlear Prosthetics*, Duke University, Durham, NC, USA, February 26-27, 2010.
137. Wilson BS: Worldwide developments and availabilities of low-cost cochlear implants. *Coalition for Global Hearing Health Conference*, American Academy of Otolaryngology – Head and Neck Surgery Foundation, Alexandria, VA, USA, June 14-15, 2010.
138. Tucci DL, Wilson BS: Global priorities for hearing loss. *Coalition for Global Hearing Health Conference*, American Academy of Otolaryngology – Head and Neck Surgery Foundation, Alexandria, VA, USA, June 14-15, 2010.
139. Rask-Andersen H (President), Baumgartner W-D, Colletti V, Gantz B, Giovannini M, Lenarz Th, Martini A, Olgun L, Ramsden R, Shannon R, Vischer M, Wilson B: Round Table conference on “Future Developments of Auditory Implants.” *ABI 2010 – State of the Art Symposium on Auditory Brainstem Implants*, Uppsala, Sweden, June 29, 2010.
140. Wilson BS: Processing strategies for central auditory prostheses. Presented in the Round Table session on “Future Developments of Auditory Implants.” *ABI 2010 – State of the Art Symposium on Auditory Brainstem Implants*, Uppsala, Sweden, June 29, 2010.
141. Wilson BS: Introduction to the Special Symposium on “The Listening Brain.” *11th International Conference on Cochlear Implants and Other Auditory Implantable Technologies*, Stockholm, Sweden, June 30 through July 3, 2010.
142. Wilson BS: The listening brain. Medizinische Hochschule Hannover, Hannover, Germany, July 8, 2010.
143. Wilson BS: Cochlear implants: Matching the prosthesis to the brain and facilitating desired plastic changes in brain function. *Symposium on Brain Machine Interfaces – Implications for Science, Clinical Practice and Society*, Ystad Saltsjöbad, Sweden, August 26-29, 2010. (This Symposium was supported by the Nobel Foundation among others.)
144. Wilson BS: Cochlear implants for the restoration of hearing. Invited lecture for Duke University course BME 265 on Neural Prosthetic Systems, Pratt School of Engineering, October 14, 2010.
145. Wilson BS: The surprising benefits of cochlear implantation for persons with high levels of residual hearing. *2nd Congress of Spanish-America on Cochlear Implants and Related Sciences*, Cartagena, Columbia, December 1-3, 2010.
146. Baumgartner W-D, Wilson BS: Vienna experience of electrical acoustic surgery. *2nd Congress of Spanish-America on Cochlear Implants and Related Sciences*, Cartagena, Columbia, December 1-3, 2010.
147. Wilson BS (moderator), Baumgartner W-D, Labadie R, Manrique M, Özgirgin N: Round Table on “Future trends in implantation.” *2nd Congress of Spanish-America on Cochlear Implants and Related Sciences*, Cartagena, Columbia, December 1-3, 2010.
148. Rajan G, Kleine Punte A, Schatzer R, Wie OB, Wilson BS, McKinnon B, Streitberger C: Round Table on “Cochlear implants in unilateral deafness.” *Conference on Hearing Implants: A Remarkable Past and a Brilliant Future*, Frankfurt am Main, Germany, December 9-11, 2010.
149. Schatzer R, Wilson BS, Lopez-Poveda E, Wolford RD, Zerbi M, Cox JH: A bio-inspired coding strategy for cochlear implants: Concept and results. *Conference on Hearing Implants: A Remarkable Past and a Brilliant Future*, Frankfurt am Main, Germany, December 9-11, 2010.
150. Wilson BS, Lorens A, Piotrowska, Skarzynski H: The surprising benefits of cochlear implantation for persons with high levels of residual hearing. *10th European Federation of Audiology Societies (EFAS) Congress*, Warsaw, Poland, June 22-25, 2011. (Presented by Artur Lorens in the special session on “International collaboration projects – 15th Anniversary of the Institute of Physiology and Pathology of Hearing.”)
151. Wilson BS: Cochlear implants: a remarkable past and a brilliant future. Seminar presentation at the University of Warwick, Coventry, UK, October 17, 2011.

152. Wilson BS: The surprising benefits of cochlear implantation for persons with high levels of residual hearing. *Presbycusis Research Meeting*, Munich, Germany, January 12-14, 2012.
153. Briand P, Buchman C, Caraway T, Gantz B, Hochmair I, Hodges A, Janssen J, Lenarz T, Luntz, M, Luxford W, Mueller J, Nedzelski J, Roehrienin G, van de Heyning P, Wilson B, Zwolan T (panelists and industry representatives): The future of cochlear implant care and technology. *12th International Conference on Cochlear Implants and Other Implantable Auditory Technologies*, Baltimore, MD, USA, May 3-5, 2012.
154. Wilson BS, Lorens A, Piotrowska, Skarzynski H: Evaluation of the relative benefits of cochlear implantation according to the level of residual hearing. *Scientific Congress in Celebration of the Grand Opening of the World Hearing Center*, Kajetany, Poland, May 10-11, 2012. (This talk was presented by Artur Lorens.)
155. Wilson BS: Cochlear implants: matching the prosthesis to the brain and facilitating desired plastic changes in brain function. One-day meeting on *Brain Centric Considerations for Cochlear Implantation*, Dallas, TX, USA, August 27, 2012.
156. Wilson BS: Design and engineering aspects of cochlear implants. Invited lecture for Duke University course BME 515 on Neural Prosthetic Systems, Pratt School of Engineering, October 30, 2012.
157. Wilson BS (moderator), Nicoletti M, Schatzer R, Visser D, Zirn S, Hemmert W, Nopp P, Stohl J: Round Table discussion on "Challenges in cochlear implants today." *2nd Munich Hearing Implant Symposium: Hearing Implants Around the World*, Ludwig Maximilians Universität, Munich, Germany, December 6-9, 2012.
158. Wilson BS: Brain centric approaches for the design, fitting, and application of cochlear implants. Guest Address at the *Annual Conference of the British Cochlear Implant Group*, on "The Hearing Brain," Ayrshire, Scotland, March 21-22, 2013.
159. Wilson BS: Acceptance remarks. *Awards Luncheon for the 2013 Lasker Awards*, New York, NY, September 20, 2013. (This speech is posted at http://www.laskerfoundation.org/awards/2013_c_accept_wilson.htm.)
160. Wilson BS: Importance of the hearing brain in cochlear implant designs and outcomes. *Brain Plasticity and Cochlear Implant Use 2013 Workshop*, New York University School of Medicine, NYU Langone Medical Center, New York, NY, USA, September 23, 2013.
161. Wilson BS: Future possibilities for combined electric and acoustic stimulation. *Hearing Preservation Workshop XII*, Heidelberg, Germany, October 10-13, 2013.
162. Wilson BS: Getting a decent, but sparse, signal to the brain of cochlear implant patients. *Workshop on Neural Imaging: From the Cochlea to the Cortex*, Arizona State University, Tempe, AZ, USA, November 4, 2013.
163. Wilson BS: Importance of the hearing brain in cochlear implant designs and outcomes. Seminar presentation at the UCL Ear Institute, University College London, London, UK, December 10, 2013.
164. Wilson BS: The development of the modern cochlear implant and the first substantial restoration of a human sense using a medical intervention. Seminar presentation at the Instituto de Neurociencias de Castilla y León, University of Salamanca, Salamanca, Spain, December 16, 2013.
165. Wilson BS: Evaluation of the relative benefits of cochlear implantation according to the level of residual hearing. *Conference on Hearing Implants for Older Adults*, New York, NY, USA, January 16-18, 2014.
166. Wilson BS: Cochlear implants: Matching the prosthesis to the brain and facilitating desired plastic changes in brain function. Seminar presentation for the Department of Biomedical Engineering and the Center for Hearing and Balance, Johns Hopkins University, Baltimore, MD, USA, February 5, 2014.
167. Wilson BS, Stohl JS: A simple but fast and useful model of the electrically stimulated auditory periphery. *Bernstein Sparks Workshop on Modeling and Signal Processing for Auditory Implants*, held in conjunction with the *13th International Conference on Cochlear Implants and Other Implantable Auditory Prostheses*, Munich, Germany, June 20, 2014.

168. Wilson BS: Cochlear implants – A remarkable past and a brilliant future. *Berufsverband cochlear implants & hearing implants – Compact, structured session & round table (*program only provided in German)*, held in conjunction with the 13th *International Conference on Cochlear Implants and Other Implantable Auditory Protheses*, Munich, Germany, June 21, 2014.
169. Wilson BS: Thinking about the hearing brain in designs and applications of cochlear implants. Ludwig Maximilians Universität, Munich, Germany, June 23, 2014.
170. Wilson BS: Cochlear implants: One of the great success stories in modern medicine. *Cochlear Implants and Deafness: Symposium in Honor of Ingeborg Hochmair-Desoyer*, Vienna, Austria, September 19, 2014. (The *Symposium* is part of the celebration for the award of the 2014 Wittgenstein Preis to Dr. Hochmair-Desoyer.)
171. Wilson BS: Design and engineering aspects of cochlear implants. Invited lecture for Duke University course BME 515 on Neural Prosthetic Systems, Pratt School of Engineering, October 28, 2014.
172. Wilson BS: What the cochlear implant has taught us about auditory coding and the hearing brain. Invited lecture for Duke University course NEUROSCI 290-01/MUSIC 290-01, “Music and the Brain,” January 21, 2015.
173. Wilson BS: The punctuation mark in an equilibrium state: modern signal processing. Special session on cochlear implants sponsored by the Committees on Psychological and Physiological Acoustics, Biomedical Acoustics, Speech Communication, and Signal Processing in Acoustics, *Annual Spring Meeting of the Acoustical Society of America*, Pittsburgh, PA, USA, 18-22 May 2015.
174. Wilson BS: Possibilities for improving the performance of cochlear implants and related hearing prostheses. Special session sponsored by the Committees on Psychological and Physiological Acoustics, Biomedical Acoustics, Speech Communication, and Signal Processing in Acoustics, *Annual Spring Meeting of the Acoustical Society of America*, Pittsburgh, PA, USA, 18-22 May 2015.

Additional Presentations

1. Wilson, BS: Problems and opportunities in the design of speech processors for cochlear implant prostheses. *Annual Meeting of the Association for the Advancement of Medical Instrumentation*, 1978. (Abstract published in Proc. AAMI Annual Meeting 13: 295, 1978)
2. Wilson BS, Joines WT, Casseday JH, Kobler JB: Identification of sites in brain tissue affected by nonionizing radiation. *2nd Annual Meeting of the Bioelectromagnetics Society*, 1980. (Abstract published in *Bioelectromagnetics* 1: 208, 1980)
3. Wilson BS, Joines WT, Casseday JH, Kobler JB: Responses in the auditory nerve to pulsed, continuous wave, and sinusoidally-amplitude-modulated microwave radiation. *2nd Annual Meeting of the Bioelectromagnetics Society*, 1980. (Abstract published in *Bioelectromagnetics* 1: 237, 1980)
4. Blackman CF, Wilson BS: Distribution of label in studies on the effects of nonionizing radiation on the association of calcium ions with brain tissue. *5th Annual Meeting of the Bioelectromagnetics Society*, 1983. (Abstract published in *Bioelectromagnetics Abstracts*, p. 73, 1983)
5. Wilson BS, Kobler JB, Casseday JH, Joines, WT: Spectral content of microwave-induced auditory stimuli as demonstrated by [¹⁴C]-2-deoxy-D-glucose uptake at the inferior colliculus. *5th Annual Meeting of the Bioelectromagnetics Society*, 1983. (Abstract published in *Bioelectromagnetics Abstracts*, p. 46, 1983)
6. Henson OW Jr., Kobler JB, Wilson BS, Bishop AL: Echo frequency and intensity optimization by mustache bats. *7th Midwinter Meeting of the Association for Research in Otolaryngology*, St. Petersburg Beach, FL, USA, February, 1984.
7. Henson OW Jr., Wilson BS, Kobler JB, Bishop AL, Henson MM, Hanson R: Radiotelemetry and computer analysis of biosonar signals emitted by the free-flying bat. *8th Midwinter Meeting of the Association for Research in Otolaryngology*, St. Petersburg Beach, FL, USA, February, 1985. (Abstract published in *ARO Abstracts*, p. 70, 1985)

8. Wilson BS, Finley CC: A computer-based simulator of speech processors for auditory prostheses. *8th Midwinter Meeting of the Association for Research in Otolaryngology*, St. Petersburg Beach, FL, USA, February, 1985. (Abstract published in ARO Abstracts, p. 109, 1985)
9. Finley CC, Wilson BS: An integrated field-neuron model of electrical stimulation by intracochlear scala-tympani electrodes. *8th Midwinter Meeting of the Association for Research in Otolaryngology*, St. Petersburg Beach, FL, USA, February, 1985. (Abstract published in ARO Abstracts, p. 105, 1985)
10. Finley CC, Wilson BS: Sampling of electric fields by myelinated intracochlear neurons. *9th Midwinter Meeting of the Association for Research in Otolaryngology*, St. Petersburg Beach, FL, USA, February, 1986. (Abstract published in ARO Abstracts, p. 170, 1986)
11. Wilson BS, Finley CC: Latency fields in electrically-evoked hearing. *9th Midwinter Meeting of the Association for Research in Otolaryngology*, St. Petersburg Beach, FL, USA, February, 1986. (Abstract published in ARO Abstracts, pp. 170-171, 1986)
12. Finley CC, Wilson BS: Field patterns in electrically-stimulated human cochlea. *International Union of Physiological Scientists (IUPS) Satellite Symposium on Advances in Auditory Neuroscience*, San Francisco, CA, USA, July 8-11, 1986.
13. Wilson BS, Finley CC, Farmer JC Jr., Weber BA, Lawson DT, Wolford RD, Kenan PD, White MW, Merzenich MM, Schindler RA: Comparative studies of speech processing strategies for cochlear implants. *90th Annual Meeting of the Triological Society*, Denver, CO, USA, April 28-20, 1987.
14. Finley CC, Wilson BS: Spiral ganglion cell body effects on neural response latency in the electrically stimulated cochlea. *13th Midwinter Meeting of the Association for Research in Otolaryngology*, St. Petersburg, FL, USA, February 4-8, 1990. (Abstract published in ARO Abstracts, pp. 331-332, 1990)
15. Wilson BS, Finley CC, Lawson DT, Wolford RD: A new processing strategy for multichannel cochlear implants. *Second International Cochlear Implant Symposium*, Iowa City, IA, USA, June 4-8, 1990.
16. Wilson BS, Finley CC, Lawson DT, Wolford RD: New levels of speech recognition with cochlear implants. *14th Midwinter Meeting of the Association for Research in Otolaryngology*, St. Petersburg, FL, USA, February 3-7, 1991. (Abstract published in ARO Abstracts, p. 35, 1991)
17. Zerbi M, Wilson BS, Finley CC, Lawson DT: A flexible speech processor for cochlear implant research. *1992 Digital Signal Processing Workshop*, Utica, IL, USA, September 13-16, 1992.
18. Loeb GE, Shannon RV, Wilson BS, Zeng F-G, Rebscher S: Design for an inexpensive but effective cochlear implant system: Recommendations of an expert panel from the 1993 Zhengzhou International Symposium on Electrical Cochlear Hearing and Linguistics. *International Cochlear Implant, Speech and Hearing Symposium*, Melbourne, Australia, October 23-28, 1994
19. Finley CC, Wilson BS: Responses of the auditory nerve to repetitive electrical stimuli as demonstrated with recordings of intracochlear evoked potentials. *18th Midwinter Meeting of the Association for Research in Otolaryngology*, St. Petersburg, FL, USA, February 5-9, 1995. (Abstract published in ARO Abstracts, p. 178, 1995)
20. Wilson BS, Finley CC: Temporal representations with cochlear implants. *III^d International Congress on Cochlear Implant*, Paris, France, April 27-29, 1995.
21. Finley CC, Wilson BS: Spatial distribution of stimulus fields and intracochlear evoked potentials as recorded from unstimulated electrodes of implanted cochlear prostheses. *19th Midwinter Research Meeting of the Association for Research in Otolaryngology*, St. Petersburg Beach, FL, USA, February 4-8, 1996. (Abstract published in ARO Abstracts, p. 108, 1996)
22. Tucci DL, Roush PA, Lawson DT, Wilson BS, Zerbi M: Modified percutaneous Nucleus cochlear implant: Surgical experience and speech recognition results. *Vth International Cochlear Implant Conference*, New York, NY, USA, May 1-3, 1997.
23. Rubinstein JT, Wilson BS, Abbas PJ: Restoration of acoustic-like patterns of auditory nerve activity with electrical stimulation. *4th European Symposium on Paediatric Cochlear Implantation*, 's-Hertogenbosch, The Netherlands, June 14-17, 1998.

24. Rubinstein JT, Miller CA, Abbas PJ, Wilson BS: Emulating physiologic firing patterns of auditory neurons with electrical stimulation. *22nd Midwinter Meeting of the Association for Research in Otolaryngology*, St. Petersburg Beach, FL, USA, February 13-17, 1999. (Abstract published in ARO Abstracts, p. 8, 1999)
25. van den Honert C, Finley CC, Wilson BS: Measurement of intracochlear evoked potentials. *1999 Conference on Implantable Auditory Prostheses, Pacific Grove, CA, USA, August 29 through September 3, 1999*. (This was a poster presentation.)
26. van den Honert C, Finley CC, Wilson BS: Measurement of intracochlear evoked potentials. *6th International Cochlear Implant Conference*, Miami Beach, FL, USA, February 3-5, 2000.
27. Tyler RS, Parkinson A, Wilson BS, Witt S, Gantz B, Rubinstein J, Wolaver A, Lowder M: Binaural cochlear implants and hearing aids and cochlear implant: Speech perception and localization. *6th International Cochlear Implant Conference*, Miami Beach, FL, USA, February 3-5, 2000. (Wilson's participation in this effort was jointly supported by the Program Project Grant on Cochlear Implants at the University of Iowa and by one the "speech processors" projects at RTI.)
28. Tyler RS, Gantz BJ, Rubinstein JT, Preece JP, Wilson BS, Parkinson AJ, Wolaver A: Distance, localization and speech perception pilot studies with bilateral cochlear implants. *3rd Congress of Asia Pacific Symposium on Cochlear Implant and Related Sciences*, Osaka, Japan, April 5-7, 2001.
29. Cartee LA, Finley CC, Wilson BS: A model of the intracochlear evoked potential. *2001 Conference on Implantable Auditory Prostheses, Pacific Grove, CA, August 19-24, 2001*.
30. Tyler RS, Gantz BJ, Rubinstein JT, Witt S, Bryant D, Wilson BS: What we have learned about binaural hearing? *7th International Cochlear Implant Conference*, Manchester, England, September 4-6, 2002.
31. Schatzer R, Wilson BS, Lopez-Poveda EA, Zerbi M, Wolford RD, Lawson DT: A novel CI speech processing structure for closer mimicking of normal auditory functions. *2003 Conference on Implantable Auditory Prostheses, Pacific Grove, CA, USA, August 17-22, 2003*. (poster presentation)
32. Skarzynski H, Wilson BS, Lorens A, Piotrowska A: Electroacoustic stimulation in patients with partial deafness. *XXXI Congress of the European Society for Artificial Organs*, Warsaw, Poland, September 8-11, 2004.
33. Adunka A, Unkelbach M, Radeloff A, Wilson BS, Gstoettner W: Outcomes of hearing preservation and cochlear vulnerability in cochlear implant recipients. *10th Symposium on Cochlear Implants in Children*, Dallas, TX, USA, March 15-19, 2005.
34. Lorens A, Wilson BS, Piotrowska A, Skarzynski H: Electric and acoustic pitch perception after Partial Deafness Cochlear Implantation (PDCI). *8th International Conference on Advances in Diagnosis and Treatment of Auditory Disorders*, Kajetany, Poland, May 19-21, 2005.
35. Cartee LA, Finley CC, van den Honert C, Lawson DT, Wilson BS: Intracochlear evoked potential responses to biphasic pulses with an interphase gap. *2005 Conference on Implantable Auditory Prostheses, Pacific Grove, CA, USA, July 30 to August 4, 2005*. (poster presentation)
36. Wilson BS, Dorman MF: A new "top down" or "cognitive neuroscience" approach to the design of cochlear implants. *2007 Conference on Implantable Auditory Prostheses, Lake Tahoe, NV, USA, July 15-20, 2007*. (poster presentation)
37. An SK, Park S-I, Lee CJ, Byun KM, Min KS, Lee JM, Wilson BS, Lawson DT, Rebscher SJ, Oh SH, Kim SJ: Design for a simplified cochlear implant system. *2007 Conference on Implantable Auditory Prostheses, Lake Tahoe, NV, USA, July 15-20, 2007*. (poster presentation)
38. Tucci DL, Wilson BS, Kaylie DM: Worldwide hearing impairment: A need for action. *9th European Symposium on Paediatric Cochlear Implantation*, Warsaw, Poland, May 14-17, 2009.
39. Schatzer R, Wilson BS, Lopez-Poveda EA, Zerbi M, Wolford RD, Cox JH, Lawson DT, Zierhofer CM: A bio-inspired nonlinear filter bank for cochlear implant speech processors. *Conference on Implantable Auditory Prostheses, Asilomar, CA, USA, July 24-29, 2011*. (poster presentation)
40. Stohl JS, Wolford RD, Wilson BS: Improving place-pitch in the apex via manipulations in phase duration. *Conference on Implantable Auditory Prostheses, Lake Tahoe, CA, USA, July 14-19, 2013*. (poster presentation)

41. Stohl JS, Wolford RD, Wilson BS: Improving channel independence before selecting electrodes for deactivation. *13th International Conference on Cochlear Implants and Other Implantable Auditory Prostheses*, Munich, Germany, June 19-21, 2014.

Chaired Conferences

1. Wilson BS (Chair): *1991 Conference on Implantable Auditory Prostheses*, Pacific Grove, CA, USA, June 2-7, 1991.
2. Wilson BS (Chair): *Mini Symposium on Cochlear Implants*, Research Triangle Park, NC, USA, February 7, 2000. (This symposium included three international speakers and one speaker from the RTI/Duke team.)
3. Miyamoto RT, Wilson BS (Co-Chairs): *Hearing Preservation Workshop*, Indiana University School of Medicine, Indianapolis, IN, USA, November 8-10, 2002.
4. Roland PS, Wilson BS (Co-Chairs): *Third Hearing Preservation Workshop*, Dallas, TX, USA, October 15-16, 2004.
5. Wilson BS, Dorman MF (Co-Chairs): *Hearing Preservation Workshop V*, Research Triangle Park, NC, USA, October 13-14, 2006.
6. von Ilberg C, Wilson BS (Co-Chairs): *Presbycusis Research Meeting*, Munich, Germany, January 12-14, 2012.

Chaired Track

1. Wilson BS, Kim SJ (Co-Chairs): Track on Neural Systems and Engineering, *World Congress on Medical Physics and Biomedical Engineering 2006*, Seoul, Korea, August 27 through September 1, 2006 (see <http://www.wc2006-seoul.org/index.htm>). Professor Kim is the Director of the Nano-Bioelectronics and Systems Research Center at Seoul National University in Seoul, Korea. The Neural Systems and Engineering track included seven sessions: (1) Neural Networks and Brain-Computer Interfaces; (2) Invited Talk I, on “Cochlear implants: A remarkable past and a brilliant future;” (3) Auditory Prosthesis; (4) Invited Talk II, on “The optic nerve visual prosthesis;” (5) Visual Prosthesis; (6) Neural Signal Processing; and (7) a poster session.

Chaired Sessions

1. Wilson BS (Chair): Session on "Cardiovascular Fluid Dynamics." *2nd Mid-Atlantic Conference on Bio-Fluid Mechanics*, Blacksburg, VA, USA, April, 1980.
2. Wilson BS (Discussion Leader): *Gordon Research Conference on Implantable Auditory Prostheses*, Tilton, NH, USA, August 19-23, 1985.
3. Wilson BS (Moderator), Dent LJ, Dillier N, Eddington DK, Hochmair-Desoyer IJ, Pfingst BE, Patrick J, Sürth W, Walliker J (Panelists): Round table discussion on speech coding. *International Cochlear Implant Symposium 1987*, Düren, Germany, September 7-11, 1987.
4. Wilson BS (Moderator): Session on “Speech Processing.” *Second International Cochlear Implant Symposium*, Iowa City, IA, USA, June 4-8, 1990.
5. Wilson BS (Chair): Session on “Audiological Assessment and Device Programming.” *First European Symposium on Paediatric Cochlear Implantation*, Nottingham, England, September 24-27, 1992.
6. Wilson BS, Dillier N (Co-Chairs): Session on “Speech Coding.” *Third International Cochlear Implant Conference*, Innsbruck, Austria, April 4-7, 1993.
7. Wilson BS (Chair), Cazals Y, Dillier N, MacLeod P, McDermott H, Pelizzone M (Panelists): Round Table on “Sound Signal Processing.” *IIIrd International Congress on Cochlear Implant*, Paris, France, April 27-29, 1995.
8. Wilson BS (Chair): Focus group on “Speech Processing.” *1995 Conference on Implantable Auditory Prostheses*, Pacific Grove, CA, USA, August 20-24, 1995.
9. Wilson BS (Chair): Session on “Basic Science and Technical Aspects.” *Third European Symposium on Paediatric Cochlear Implantation*, Hannover, Germany, June 6-8, 1996.

10. Wilson BS (Discussion Leader), Böex-Spano C (Discussion Co-Leader), Svirsky M (Discussion Co-Leader): Focus group on "Issues in Speech Processor Design." *1997 Conference on Implantable Auditory Prostheses*, Pacific Grove, CA, USA, August 17-21, 1997.
11. Wilson BS (Session Moderator): Evaluation of combined electric and acoustic stimulation of the auditory system. *Hearing Preservation Workshop*, Indiana University School of Medicine, Indianapolis, IN, USA, November 8-10, 2002.
12. Hochmair E, Wilson B, Lenhardt M, Czyzewski A (Co-Chairs): Session on "Cochlear and Brain Stem Implants and Related Audiological Problems." *VII International Conference on Cochlear Implants and Related Audiological Sciences*, Warsaw – Kajetany, Poland, May 22-25, 2003.
13. Wilson B, Skarzynski H (Co-Chairs): Satellite Symposium on "Partial deafness cochlear implantation." *VII International Conference on Cochlear Implants and Related Audiological Sciences*, Warsaw – Kajetany, Poland, May 22-25, 2003.
14. Wilson BS, Hartmann R, Klinke R (Co-Chairs): Special session on "Future directions for cochlear implants," Department of Physiology, Institute of Physiology III, JW Goethe Universität, Frankfurt, Germany, October 16, 2003. (This session was held the day before the *Hearing Preservation Workshop II*, also held in Frankfurt. The session included approximately 30 participants.)
15. Wilson BS (Chair): Session on "Clinical Issues." *Hearing Preservation Workshop II*, Frankfurt, Germany, October 17-18, 2003.
16. Wilson BS, Talavage TM (Co-Chairs): Session 2C. *Eighth International Cochlear Implant Conference*, Indianapolis, IN, USA, May 10-13, 2004.
17. Wilson BS (Chair): Session on "Neural Enhancement." *Hearing Preservation Workshop III*, Dallas, TX, USA, October 15-16, 2004.
18. Wilson BS (Moderator): Session on "Signal Processing and Speech in Noise." *2005 Conference on Implantable Auditory Prostheses*, Pacific Grove, CA, USA, July 30 to August 4, 2005.
19. Wilson BS (Chair): Session on "Hearing Preservation, Partial Deafness Cochlear Implantation, and EAS." *Hearing Preservation Workshop IV*, Warsaw-Kajetany, Poland, October 14-15, 2005.
20. Wilson BS (Chair): Session NP1: Auditory Prosthesis. *World Congress on Medical Physics and Biomedical Engineering 2006*, Seoul, Korea, August 27 through September 1, 2006.
21. Wilson BS (Co-Chair with R Schatzer): Session on "Speech Processing – Temporal Coding, Preprocessing, and New Designs." *11th International Conference on Cochlear Implants in Children*, Charlotte, NC, USA, April 11-14, 2007.
22. Wilson BS (Co-Chair with R Schatzer): Session on "Speech Processing – Current Steering." *11th International Conference on Cochlear Implants in Children*, Charlotte, NC, USA, April 11-14, 2007.
23. Wilson BS: Session on "Novel Stimulation and Signal Processing Strategies and Modeling." *2007 Conference on Implantable Auditory Prostheses*, Lake Tahoe, NV, USA, July 15-20, 2007.
24. Wilson BS: Session on "Electric Acoustic Stimulation." *Hearing Preservation Workshop VI*, Antwerp, Belgium, October 19-20, 2007.
25. Wilson BS (First Chair), Vermeire K: Session on "Coding Strategies 1." *9th European Symposium on Paediatric Cochlear Implantation*, Warsaw, Poland, May 14-17, 2009.
26. Wilson BS (First Chair), von Ilberg Ch: Session on "Results of Electric Acoustic Stimulation." *9th European Symposium on Paediatric Cochlear Implantation*, Warsaw, Poland, May 14-17, 2009.
27. Wilson BS: Afternoon session for Friday, February 26. Duke Institute for Brain Sciences workshop on *Listening with the Brain: New Approaches to Optimizing the Effectiveness of Cochlear Prosthetics*, Duke University, Durham, NC, USA, February 26-27, 2010.
28. Wouters J, Wilson BS: Second session on "Coding Strategies and Electrode Designs." *11th International Conference on Cochlear Implants and Other Auditory Implantable Technologies*, Stockholm, Sweden, June 30 through July 3, 2010.
29. Wilson BS: Chairman for the invited lecture by Prof. Marco Pelizzone, "Beyond cochlear implants: vestibular and retinal implants. *10th European Symposium on Paediatric Cochlear Implantation*, Athens, Greece, May 12-15, 2011.

30. Coninx F, Lorens A, Wilson B, McPherson D: Special session on “International collaboration projects – 15th Anniversary of the Institute of Physiology and Pathology of Hearing,” *10th European Federation of Audiology Societies (EFAS) Congress*, Warsaw, Poland, June 22-25, 2011.
31. Wilson BS: Chairman of the session on “Outcomes Assessments,” *10th Hearing Preservation Workshop*, London, UK, October 13-16, 2011.
32. Wilson BS: Chairman of the session on “Physiological Assessment – from Periphery to Cortex,” *Hearing Preservation Workshop*, Toronto, Canada, October 18-20, 2012.
33. Wilson BS: Chairman of the session on “Outcome prediction and improvement,” *Hearing Preservation Workshop XII*, Heidelberg, Germany, October 10-13, 2013.
34. Wilson BS, Helms J: Chairpersons for the Round Table on “Cochlear implants: A remarkable past and a brilliant future – The past presidents panel,” *13th International Conference on Cochlear Implants and Other Implantable Auditory Prostheses*, Munich, Germany, June 19-21, 2014.
35. Visser D, Wilson BS: Chairpersons for the keynote session on “Binaural hearing,” *13th International Conference on Cochlear Implants and Other Implantable Auditory Prostheses*, Munich, Germany, June 19-21, 2014.
36. Wilson BS: Chairman of the session on “Perception and Performance in the APEX,” *Conference on the APEX of the Cochlea – From Neuroanatomy to Electrical Stimulation*, Chapel Hill, NC, USA, September 4-7, 2014.
37. Wilson BS, Dorman MF: Celebration of the modern cochlear implant and the first substantial restoration of a human sense using a medical intervention. Special session sponsored by the Committees on Psychological and Physiological Acoustics, Biomedical Acoustics, Speech Communication, and Signal Processing in Acoustics, *Annual Spring Meeting of the Acoustical Society of America*, Pittsburgh, PA, USA, 18-22 May 2015.

Selected Abstracts

Abstracts have been published for the great majority of the keynote, invited, and other presentations listed in this CV. A few representative abstracts are listed below.

1. Wilson BS, Finley CC: Latency fields in electrically-evoked hearing. *Association for Research in Otolaryngology (ARO) Abstracts* 9: 170-171, 1986.
2. Soli SD, Wilson BS: Within-subject comparisons of analog and pulsatile speech processors for cochlear implants. *J Acoust Soc Am* 84: S41, 1988.
3. Wilson BS, Finley CC, Lawson DT, Wolford RD: New levels of speech recognition with cochlear implants. *ARO Abstracts* 14: 35, 1991.
4. Wilson BS: Strategies for representing speech with cochlear implants. *J Acoust Soc Am* 89, Suppl. 1: 1957, 1991.
5. Wilson BS: Progress in the development of speech processors for cochlear prostheses. *J Acoust Soc Am* 95: 2905, 1994.
6. Wilson BS, Lawson DT, Zerbi M, Finley CC: New developments in speech processors. *ARO Abstracts* 18: 97, 1995.
7. Finley CC, Wilson BS: Responses of the auditory nerve to repetitive electrical stimuli as demonstrated with recordings of intracochlear evoked potentials. *ARO Abstracts* 18: 178, 1995.
8. Finley CC, Wilson BS: Spatial distribution of stimulus fields and intracochlear evoked potentials as recorded from unstimulated electrodes of implanted cochlear prostheses. *ARO Abstracts* 19: 108, 1996.
9. Rubinstein JT, Miller CA, Abbas PJ, Wilson BS: Emulating physiologic firing patterns of auditory neurons with electrical stimulation. *ARO Abstracts* 22: 8, 1999.
10. Wilson BS: Cochlear implants: A remarkable past and a brilliant future. *Wein Med Wochenschr* 156 [Suppl 119]: 1, 2006.